

**ERIE COUNTY  
DEPARTMENT OF ENVIRONMENT & PLANNING  
DIVISION OF SEWERAGE MANAGEMENT**



**DESIGN REQUIREMENTS  
FOR  
SUBDIVISIONS & SANITARY  
SEWER EXTENSIONS  
WITHIN ERIE COUNTY SEWER DISTRICTS**

**August 2024**

# CONTENTS

<u>SECTION</u>	<u>PAGE</u>
I. INTRODUCTION	1
II. ENGINEERING DOCUMENTS	1
III. DESIGN OF GRAVITY SEWERS	2
IV. DOWNSTREAM CAPACITY	3
V. I & I REMEDIAL WORK	3
VI. EASEMENTS	4
VII. DETAILS AND TESTING	4
VIII. PUMPING STATIONS	4
1. SITE LAYOUT	6
2. FORCE MAIN	9
3. PUMP CHAMBER	9
4. VALVE CHAMBER	10
5. PRESSURE GAUGE	10
6. COMMINUTOR	10
7. PUMPS	10
8. CONTROL PANEL	12
9. STANDBY GENERATOR	12
10. TRANSFER SWITCH	13
11. LOAD BANK	13
12. POWER	13
13. ELECTRICAL	13
14. CELLULAR TELEMETRY	14
IX. RECORD DRAWINGS	14
X. ADDITIONAL REQUIREMENTS	15
APPENDIX "A": PROJECT REVIEW CHECKLISTS	
A1: SUBDIVISION & SANITARY SEWER EXTENSION PROJECT REVIEW	
A2: NON – RESIDENTIAL PROJECT REVIEW	
A3: PUMPING STATION REQUIREMENTS	
APPENDIX "B": GENERAL NOTES	
B1: SUBDIVISIONS AND SANITARY SEWER EXTENSIONS	
B2: NON-RESIDENTIAL PROJECTS	
APPENDIX "C": RECORD DRAWING SUBMITTAL - SAMPLE CERTIFICATION LETTER	
APPENDIX "D": STANDARD DETAILS	
APPENDIX "E": TESTING FORMS	

APPENDIX “F”: I & I CONTRIBUTION SOURCES AND ESTIMATES TABLE

APPENDIX “G”: INDUSTRIAL WASTEWATER SURVEY

G1: COUNTY OF ERIE WATER RESOURCE RECOVERY FACILITIES

G2: BUFFALO SEWER AUTHORITY WWTP

G3: AMHERST WWTP

APPENDIX “H”: SUBDIVISIONS AND EXTENSIONS FORMS

H1: APPLICATION FORM (92-19-4)

H2: PROJECT DATA FORM (BMW-65)

APPENDIX “I”: PUMPS AND WETWELL (PUMP CHAMBER) SIZING

ERIE COUNTY DEPARTMENT OF ENVIRONMENT AND PLANNING  
DIVISION OF SEWERAGE MANAGEMENT (DSM)  
DESIGN REQUIREMENTS FOR  
SUBDIVISIONS AND SANITARY SEWER EXTENSIONS  
WITHIN ERIE COUNTY SEWER DISTRICTS (ECSD)

I. INTRODUCTION

The intent of these requirements is to provide the design engineer with guidelines and instructions whereby proposed sanitary sewer extensions within Erie County Sewer Districts (ECSD) can be designed in conformance to the Erie County Department of Environment and Planning, Division of Sewerage Management (hereinafter referred to as the DSM) *Specifications for Subdivisions and Sanitary Sewer Extensions*, the *DSM Policies and Procedures*, and the *Erie County Sewer Districts Rules and Regulations*.

The design of the gravity sanitary sewer shall comply with these requirements, the *Great Lakes - Upper Mississippi River Board (GLUMRB) Recommended Standards for Wastewater Facilities (hereinafter referred to as the Ten State Standards) - latest edition* and the *Department of Environmental Conservation's (DEC) Design Standards for Wastewater Treatment Works - latest edition*.

The design engineer should make every effort to design gravity sanitary sewer service to a property or proposed development.

II. ENGINEERING DOCUMENTS

- A. The required drawings as listed in Appendix "A1" shall be on "D" sized 24"X36" paper only and include, but not be limited to the following:
1. Title block consisting of Project Name, Project Location, and the name of the company or the design engineer.
  2. The scale of the drawings with all match lines labeled. 1"=50' horizontal, and 1"=5' vertical are the smallest ratios acceptable as scales.
  3. The north arrow consistently oriented either up or to the right on each sheet.
  4. A legend which correctly identifies all symbols used on the plans.
  5. Project location map showing sufficient details with the site identified. Include a north arrow.
  6. Stationing on the plan and profile for cross-referencing.
  7. A utility plan clearly depicting all existing and proposed site features, including contours or spot elevations.
  8. Benchmarks identified on the plans for each project greater than 1000 LF of proposed sanitary sewer. Provide additional benchmarks at 1000 LF intervals.
  9. The invert elevation of the connection manhole as a vertical.

10. Key map showing the entire project, if the project is shown on more than one sheet. Also, all match lines shall be properly identified.
11. Profiles for all water and sanitary sewer mains. All utility crossings (water, sanitary sewer, storm, etc.) shall be shown on the profile.
12. The most current DSM standard sanitary sewer details.
13. Map cover, if applicable.
14. All plan sheets must be stamped and signed by a professional engineer licensed in New York State.

- B. Complete Application (Form 92-19-4)
- C. Complete Project Data Form 92-15-8 (BMW-65)
- D. Engineer's Report
- E. Certified Downstream Capacity Analysis
- F. EAF Form or SEQRA determination
- G. Industrial Waste Survey (Non-Residential projects)

### III. DESIGN OF GRAVITY SEWERS

Dual sanitary sewers within a subdivision are not required, but not prohibited.

The main runs of sanitary sewer lines shall be designed at minimum grade to allow for maximum future extensions, including lands which may lie outside the present boundaries of the Erie County Sewer Districts. Main runs of sanitary sewer are those sewer lines capable of being extended to properties inside or outside of the proposed project boundaries.

All other sanitary sewer lines within the project shall be designed at a nominal depth of eight (8') feet when available. If an eight (8') foot nominal depth is not provided, the design engineer, through the grading plans, shall demonstrate that the building sewer will have a minimum cover of three (3') feet over the entire building sewer for all proposed building lots. This demonstration is to include the top of the cellar wall elevation for each building tributary to a sewerline of less than eight (8') feet deep and for "C" type lot grading. **Individual lots served with pumps will not be accepted and must be labeled as "EXCEPTION".**

The difference in manhole inlet/outlet invert elevations shall be a maximum of 0.3' for pipes of equal diameter, unless an inside drop is provided (for 2' drops or more). Outside drops are prohibited.

Manholes shall be located on the common lot lines of sub-lots, if not feasible then at the midpoint of sub-lots, and outside of sidewalk areas.

Any sanitary sewer line entirely or partially designed to be constructed in a fill area shall comply with the following: -

1. Show and label the fill areas on the profile sheets and include the note “Fill shall be installed and satisfactorily compacted prior to the installation of the sanitary sewer lines.”
2. Fill material shall be free of debris, frozen material, large clods or stones, organic matter, or other unstable materials.
3. Fill material shall be deposited in horizontal layers not exceeding six (6”) inches in thickness prior to compaction.
4. Compaction shall conform to *Section 203-3.12* of the *New York State Department of Transportation – Standard Specifications*. Also, a minimum of 95% of Standard Proctor Maximum Density will be required. If fill has been placed for a minimum of one (1) year prior to installation of sewers, the Proctor test may be waived.

The General Notes for Subdivisions & Sanitary Sewer Extensions within Erie County Sewer Districts, shown in Appendix” B” must be included with the plan details.

#### IV. DOWNSTREAM CAPACITY

The New York State Department of Environmental Conservation in conjunction with the Erie County Sewer Districts Rules and Regulations require a detailed Downstream Capacity Analysis (DSCA) for any project that will consist of any sanitary sewer extension (pipe is 8 inch in diameter or larger), or a subdivision fronting the far-side of existing sewers (5 lots or more), or contributes 2500 gallons per day or more of residential sewage alone. **The Design Engineer shall obtain the Division of Sewerage Management approval of the Capacity Analysis Report prior to being certified by a New York State Licensed Professional Engineer. Both the Downstream Capacity Analysis and Engineer’s Certification shall be included in the Engineer’s Report for the proposed project.** Such analysis shall consist of:

- (a) A brief narrative and a detailed map showing the downstream routing of the sanitary sewers from the proposed project site to the Water Resource Recovery facility. The map shall include pipe size and theoretical capacity.
- (b) Recent wet weather flow monitoring data obtained by flow meters and the proposed flow shall be analyzed relative to theoretical capacity at each key node and pumping stations.
- (c) At minimum three (3) nodes shall be monitored in locations specified by the DSM.
- (d) At each node a flow meter shall be installed.
- (e) Flow measuring shall continue until a significant rain event occurs but does not have to exceed 3 months.
- (f) A significant rain event is defined as a daily rainfall amount of 0.5” or greater.

#### V. I & I REMEDIAL WORK

Any project that requires any sanitary sewer extension (pipe is 8 inch in diameter or larger), or a subdivision fronting a near-side or a far-side of existing sewers (5 lots or more), or any connection designed to convey an **average daily flow of 2500 gpd** or more of residential

**sewage alone** must perform Inflow/Infiltration (I&I) remedial work. The amount of remedial work required will be equal to four times the proposed peak flows. The remedial work will be performed on existing building sewers, or equal. The remedial work location(s) will be identified by the DSM and then assigned to the Development. The actual number of building sewers to be remediated will be based on four times the proposed peak flows and the I&I contribution source and estimates table found in Appendix “F”. The I&I contribution source and estimates table was initially approved by NYSDEC on June 6, 2005. On a request by the NYSDEC the table was modified and re-approved by NYSDEC on October 1, 2010. A commitment letter from the developer to perform the required I&I remedial work shall be provided to the DSM before final approval of plans.

## VI. EASEMENTS

The DSM during its review of the sanitary sewer plans will determine the size and location of all necessary easements for both maintenance and future extensions. Generally, the width of an easement is 20-feet for sewerlines 11-feet deep or shallower, 30-feet for sewerlines between 11-feet and 18-feet deep or on back or side lot lines or around cul-de-sacs and are determined on a case-by-case basis for sewer lines deeper than 18-feet. **Where there is developable land behind or adjacent to a proposed subdivision or a sanitary sewer extension, an easement for a future outlet sewer is required.** Sanitary sewer easements shall not be designated for any other utility without the approval of the DSM. If approved, all other utilities shall have a minimum of five (5) feet separation from the sanitary sewer lines.

## VII. DETAILS AND TESTING

The design engineer shall include all applicable *DSM Standard Details* that pertain to a specific project.

The detail sheets are also to include the required tests and their procedures (i.e. hydrostatic [infiltration or exfiltration], deflection, and air). On a case-by-case basis, the DSM may accept ultrasonic testing and internal telespection of the sewers in lieu of hydrostatic testing and air testing. The deflection test will be required for all cases. Further, vacuum testing of the manholes is also acceptable. All testing shall be in accordance with Section 02595—3.02 of the *DSM Specifications for Subdivisions and Sanitary Sewer Extensions*.

## VIII. PUMPING STATIONS

**Sewage pumping stations for subdivisions are discouraged.**

The Design Engineer shall demonstrate (with topographical information for the area surrounding the proposed development along with existing sewer facilities information) that there is no alternative to a pumping station, and that a proposed pumping station location can serve the entire tributary area. **Unavailability of easements is not sufficient justification for a**

**pumping station.** The DSM will investigate all feasible and possible alternatives to service a subdivision or an extension by means of a gravity sewer system to eliminate the need for a pumping station.

New sewage pumping stations are only permitted where there is no alternative available and there are sufficient units (minimum 50 single family homes or 70 multiunit developments i.e., patio homes or townhomes but not apartment complex) to justify the associated operational expense. Pumping stations servicing apartment complex shall remain privately owned, operated and maintained by the owner.

Any pumping station proposed shall be designed such that all tributary areas within the district will be able to access and utilize the pumping station in the future. This may mean that the wet well, force main, and electrical service have to be sized larger than what is immediately needed for the subdivision plan. Pumps designed for less than the ultimate tributary area will be reviewed on a case-by-case basis. Access easements for future sewer lines from outside the proposed development shall also be provided under such circumstances.

In certain situations, a proposed development may be tributary to an existing sewage pumping station which has insufficient capacity to accept additional flow. In such cases, terms of the pumping station upgrade will be determined and negotiated with the developer on a case-by-case basis.

Proposed pumping stations are to be all new construction of submersible design with two (2) identical pumps. Three phase power is required. Standby power generation is necessary. A dedicated site of sufficient size for required facilities must be provided.

Other designs, such as for above ground (suction type) pumping stations, may be considered on a case-by-case basis. If this type of pumping station is proposed, a preliminary approval by DSM is required before design drawings are submitted. Also, the following conditions must be complied with:

- a. Vacuum assist is not acceptable.
- b. Electrical work, control panels, and buildings are not allowed over the wetwell.
- c. Prefabricated enclosures are generally not acceptable unless approval is obtained from the DSM.
- d. Facilities exposed to weather and requiring maintenance other than equipment removal are not acceptable.

For any completed pumping station, a continuous three (3) day test is required prior to final acceptance. See the *DSM Specifications for Subdivisions and Sanitary Sewer Extensions* for testing procedures.

A comminutor or similar grinding unit is required for all pumping stations servicing more than 500 homes, or 50 home equivalents in terms of design flow for Non-Residential, Institutions



(i.e., Assisted Living), Industries, or Commercial Developments. All grinder assemblies shall be in accordance with Section 15330 of the *DSM Specifications for Subdivisions and Sanitary Sewer Extensions*.

These pumping station requirements are not intended to constrain pleasing designs which will blend into aesthetic subdivisions. Site designs other than rectangular may be submitted. Building exteriors of various materials will be considered and decorative durable fences may best serve to enhance new neighborhoods.

If it has been determined that a sewage pumping station is required for a proposed development, the following shall be provided:

## 1. SITE LAYOUT

### a. Area and Title

The following minimum site sizes shall be provided and deeded fee simple to the County:

- i. For 50 to 250 single family homes connected: (50' x 100'), 5000 square feet minimum.
- ii. For 251 to 500 single family homes connected (or where the standby generator requirement is greater than 15kw): (70' x 120'), 8400 square feet minimum.
- iii. Over 500 single family homes connected: site requirements are to be determined on a case-by-case basis. Generally, wetwell-drywell designs with a comminutor or similar grinding unit are required.

The layout shall allow a maintenance vehicle to turn around within the site.

Typical site layouts showing the minimum site requirements for sewage pumping stations for than 250 homes or less connected, and for 251 through 500 homes connected or standby generator greater than 15 kW are shown in Appendix "D"- DSM Standard Detail Nos. 38 & 40. Specific design layouts are to be submitted.

**The pumping station site shall be deeded fee simple to the County of Erie on behalf of the specific sewer district upon project completion, acceptance, and certification and prior to tributary sewer connection permits being issued.**

### b. Building

A building shall be provided on the site generally as shown on the *DSM Standard Details*. The building design shall be subject to approval of the DSM and shall meet all applicable code requirements. Generally, the building shall be placed on a reinforced concrete slab on grade, insulated to *NYS Energy Code standards*, and shall have a no maintenance exterior finish. The roof shall carry a minimum 20-year warranty. Electric heat with thermostatic control shall be provided. The building, vents, doors, and windows shall be vandal resistant. The

interior finish shall be suitable for mounting electrical motor controls and for installing or storing a standby power unit, including above ground fuel storage. An outdoor mounted generator receptacle shall be installed when a portable generator is called for.

The building shall have a mounted exterior light(s) illuminating the pumping station and building entrance area (270° coverage) operated by a manual switch located inside the building.

Two (2) double electrical power ground fault type outlets shall be provided inside the building, along with a ceiling light with wall switch in each room. All electrical wires and cables shall be in accordance with Section 16120 of the *DSM Specifications for Subdivisions and Sanitary Sewer Extensions*.

One - six (6) square foot exterior window (minimum) facing the wet well and adjacent to the control panel shall be provided with maintenance free exterior, vandal resistant laminated glass glazing (clear lexgard laminators mp750 or sp1250 as manufactured by Consolidated Glass Holdings- Dlubak Specialty Glass Corporation, or equal), and vandal resistant stainless steel insert screen. The windowsill shall not be more than four (4') feet above the floor. If the window is non-opening, a louvered vent with exhaust fan and thermostatic control shall be provided. In pumping stations having an in-place generator, a non-opening fire rated view window, six (6) square feet in area, is to be provided on the interior wall. All windows shall be in accordance with Section 08510 of the *DSM Specifications for Subdivisions and Sanitary Sewer Extensions*.

A 36-inch-wide insulated steel door with vandal resistant laminated glass view window shall be provided for pumping stations with an in-place generator set. Where the generator set cannot be removed through the exhaust louver, a double door shall be provided. Double doors are required when a portable generator set is supplied. All doors shall be equipped with panic bar type openers. All doors shall be in accordance with Section 08130 of the *DSM Specifications for Subdivisions and Sanitary Sewer Extensions*

Lock sets shall be Kaba Locksets keyed to ECSD requirements.

Specifications for all building components shall be in conformance with the International and NYS Building Code, subject to approval by the DSM and the Erie County Department of Public Works.

c. Sidewalk and Approach Apron

Both the sidewalk and approach apron are to be provided and match adjacent properties. All concrete sidewalks and approach aprons shall be as shown in accordance with Section 02600 of the *DSM Specifications for Subdivisions and Sanitary Sewer Extensions*

d. Unpaved Areas in Pumping Station Sites

The design of all unpaved areas shall be as shown in Appendix “D”- DSM Standard detail Nos. 38 & 40 in accordance with Section 02750 of the *DSM Specifications for Subdivisions and Sanitary Sewer Extensions*.

e. Water Supply

A minimum ¾” water service shall be provided to the pumping station. This water service connection is to be designed to provide adequate flow. In some cases, larger than ¾” pipe is required depending on the existing flow requirements and pressure. Provide a drain hole from the casing and in-line corporation stop with valve box.

An Erie County Water Authority (ECWA) approved backflow preventer, Reduced Pressure Zone (RPZ), is to be provided with the water service.

f. Perimeter Fence and Gate

A minimum six (6’) feet high chain link fence is to be provided. All fencing material and installation shall conform to Section 02712 of the *DSM Specifications for Subdivisions and Sanitary Sewer Extensions*.

Decorative fences or alternate materials may be submitted for consideration.

g. Drainage

If surface drainage facilities are required on the site, they shall be located and designed to prevent ponding so as not to interfere with the use of the site, and shall conform to the City, Town, or Village requirements for drainage structures within the proposed development.

h. Conduit

A minimum one (1”) inch diameter schedule 80 polyvinyl chloride (PVC) conduit is to be provided underground between the building and wet well for future use (i.e. chemical degreaser drip). This conduit is in addition to any electrical conduit and shall be capped on both ends.

i. Work Lights

Two portable explosion proof work lights with cords of sufficient length to reach from a power plug to the wet well and valve chamber shall be supplied.

## 2. FORCE MAIN

At maximum design flow, a sewage velocity of at least 2 feet per second (FPS) shall be maintained in the Force Main. Consideration should be given to attain solids pickup velocities of 4 FPS. Velocity calculations shall be based on the actual inside pipe diameter. For the installed force main a two (2) hour hydrostatic test will be required. Such test shall be performed at 250% of the design pressure and must meet the allowable leakage amount based on actual length and number of joints in the force main.

Also, the design and testing shall conform to Section 02594 of the *DSM Specifications for Subdivisions and Sanitary Sewer Extensions*.

## 3. PUMP CHAMBER

All concrete reinforcement shall conform to Section 03200 of the *DSM Specifications for Subdivisions and Sanitary Sewer Extension*. The wet well shall be reinforced concrete conforming to the *DSM Specifications for Subdivisions and Sanitary Sewer Extensions*; and shall be designed for 12-inches nominal vertical distance between lead pump on and off at ultimate peak flow design. Exceptions shall be subject to DSM approval. Wet wells, where greater than the minimum size, shall be sized for ten (10) pump starts per hour at ultimate peak flow design. Generally, the selected pump shall be rated as twice the proposed peak flow (Pumps or pump impellers for less than ultimate peak flow design capacity may be permitted where part of the pumping stations tributary area is located outside of the proposed development. However, this shall not result in a smaller wet well.) The method of sizing both pump and wet well shall generally follow the recommendations of the *Submersible Wastewater Pump Association (SWPA)* in the *Submersible Sewage Pumping Systems Handbook*.

Wet well volume in gallons (minimum effective pump cycle volume in gallons) equals the minimum cycle time in minutes (defined as the amount of time it takes to raise the liquid to the start level and then to draw it back down to the stop level. The minimum cycle time is six (6) minutes (“based on ten (10) starts per hour, as recommended by most submersible motor manufacturers”) times ultimate pump capacity in gallons per minute (gpm) divided by four (4).

All square wet wells require filleted corners to achieve a round area at the bottom of the well, in addition to bottom slope requirements.

Wet well construction shall be reinforced concrete with a base, concrete pipe barrel, and concrete cover. Steel underground structures are not acceptable. The design shall prevent floatation. The exterior surface of the wet well shall, at minimum, be coated with Koppers bitumastic material.

The duplex aluminum hinged access cover shall provide a minimum 60” x 60” clear opening, or larger, if necessary, for pump removal. Each cover shall be equipped with a locking device keyed to ECSD requirements and a recessed handle.

A concrete hopper is to be provided in the wet well bottom. The influent pipe is to be baffled for turbulence reduction.

All operating and control levels shall be noted on the plans.

A four (4") inch metal U-type vent pipe with stainless steel bird screen is required. If steel pipe is used, it shall be galvanized.

All sewage piping within the pumping station is to be ductile iron flanged as specified in Section 02594 of the *DSM Specifications for Subdivisions and Sanitary Sewer Extensions*.

#### 4. VALVE CHAMBER

Valve chambers shall be reinforced concrete with a base and concrete cover. The design shall prevent floatation. The duplex aluminum hinged access cover shall provide a minimum 60" x 60" clear opening or larger. Each cover shall be equipped with a locking device keyed to ECSD requirements and a recessed handle. A fixed in-place, aluminum or fiberglass ladder shall be provided. A cast iron drain line with a cast iron trap and check valve is required to drain the sloped floor to the wet well.

A valve standpipe with an appropriate size Evertite male adapter is required.

#### 5. PRESSURE GAUGE

A single liquid filled pressure gauge, reading in feet of head, shall be mounted on the common discharge force main. The gauge full scale shall be the lowest obtainable for the expected pump pressure range and shall not be more than twice the design pressure of the pump installed.

For above ground (suction type) or dry well pump stations, pressure gauges on the common discharge force main and each suction leg are required, mounted as shown on the *DSM Details*. The design of the pressure gauge shall be in accordance with Section 15172 of the *DSM Specifications for Subdivisions and Sanitary Sewer Extensions*.

#### 6. COMMINUTOR

A comminutor or grinder device is required for large pumping stations (serving 500 or more residential units) or for pumping stations serving institutional, industrial or large commercial developments (50 equivalent units on a design flow basis). The Design Engineer shall submit a detailed design for prior approval. All grinder devices shall be in accordance with Section 15330 of the *DSM Specifications for Subdivisions and Sanitary Sewer Extensions*.

#### 7. PUMPS

##### a. General

Two (2) identical submersible UL explosion proof pumps are required to be installed. **One (1) complete spare pump and motor shall also be supplied to the district.** The pumps shall be supplied as one factory built automatic duplex pumping unit. The principal items of the pumping unit shall include two (2) submersible centrifugal sewage pumps; stainless steel guide rails, wet well access cover, discharge seal and elbow, and all hardware; motor control center with thermal magnetic circuit breakers, magnetic motor starters, and automatic level control system to make a complete working system.

Pump selection shall provide for the most efficient pump through the projected range of flows and total dynamic heads, except that standard sizes may be required by the DSM in some circumstances. The minimum capacity of one (1) pump shall be 136 gpm for a four (4") inch diameter force main and 200 gpm for a six (6") inch diameter force main.

The pump shall have a minimum 3½-inch discharge with 125-pound standard cast iron flange fitting.

The design of submersible sewage pumps shall be in accordance with Section 15351 of the *DSM Specifications for Subdivisions and Sanitary Sewer Extensions*.

b. Pump Motor

The submersible pump motor shall be of such horsepower (hp) and voltage (single phase or three phase) as required, with motor and pump furnished as an integral unit. Motor shall be suitable for Class 1, Division 1, Group D, hazardous locations. Motor shall be of air-filled type with Class B insulation system and Class F materials rated for continuous duty in 40°C liquids. All motors and motor starters shall be in accordance with Sections 16150 and 16160 of the *DSM Specifications for Subdivisions and Sanitary Sewer Extensions*, respectively.

c. Warranty

The manufacturer of the pumping unit shall warrant it to be of quality construction, free from defects in material and workmanship.

The equipment, apparatus, and parts furnished shall be guaranteed for a period of one (1) year, excepting those items that are normally consumed in service, such as light bulbs, oil, grease, packing, o-rings, etc. The pumping unit manufacturer shall be solely responsible for the guarantee of the unit and all components.

The warranty will become effective upon the acceptance of the facility by the DSM.

Major components, such as pumps, pump motors, etc., failing to perform as specified or as represented by the manufacturer, or proven defective in service during the guarantee period, shall be replaced, repaired, or satisfactorily modified by the manufacturer without cost of parts or labor to the DSM. After start-up service has been performed, labor to replace accessory items, such as electrical components or other accessible and easily serviced parts, shall be the

responsibility of the Developer. Such components, parts, or repairs determined by the manufacturer to have failed because of defective workmanship or materials will be replaced or repaired by the Developer.

#### 8. CONTROL PANEL

All controls are to be built into a National Electrical Manufacturers Association (NEMA) 1 cabinet mounted inside the control building.

Control panel must operate pumps in Class 1, Division 1 areas.

Generator receptacle to be Hubbell. The Developer shall coordinate with the DSM, for the model required.

All devices are to be lockable and tamper proof. Locks shall be keyed to ECSD requirements. All control stations shall be in accordance with Section 16135 of the *DSM Specifications for Subdivisions and Sanitary Sewer Extensions*.

All disconnects, indicators, and controls shall be clearly marked using self-sticking labels as described in Section 16120 of the *DSM Specifications for Subdivisions and Sanitary Sewer Extensions*.

#### 9. STANDBY GENERATOR

A standby generator set shall be supplied with each pumping station. The standby generator set will be a portable unit for less than 250 units connected, unless otherwise required by the DSM. Standby generators shall be permanently installed in place for greater than 250 homes connected or if greater than 15 kilowatts.

The sizing of the generator shall be based at a minimum but not limited to the total KW required for the following:

- Pump #1
- Pump #2
- Exhaust Fan(s)
- Heater Unit(s)
- Odor Control (if necessary)
- Sump Pump(s)
- Light(s)
- Compressor

Dual independent power sources from different electrical substations may be considered. Additional utility expenses for two (2) power sources shall be fully prepaid by the Developer prior to acceptance. In those instances where there will be two (2) power sources, provisions to allow for connection of a portable generator shall be incorporated into the pumping station.

The fuel tank sizing at minimum shall be based on eight (8) gallons of fuel per hour per 100 kW, or as recommended by the manufacturer. Natural gas generators are

also acceptable. All standby generators shall be in accordance with Section 16220 of the *DSM Specifications for Subdivisions and Sanitary Sewer Extensions*.

#### 10. TRANSFER SWITCH

A manually operated transfer switch shall be installed when used in conjunction with a portable generator. An automatic transfer switch shall be installed for an in-place generator. The transfer switch shall be the bypass/isolation type.

The transfer switch, as well as all other components of the installation, shall meet the requirements of the power utility and Section 16260 of the *DSM Specifications for Subdivisions and Sanitary Sewer Extensions*.

#### 11. LOAD BANK

A load bank shall be supplied with the in place standby generator. The load bank shall be sized to fully exercise the standby generator on a continuous basis. The load bank shall be a complete manufactured unit suitable for mounting on a concrete pad outside the building and shall be supplied with all necessary connection cables, plugs, etc. The unit shall be tested together with the standby generator supplied.

The specifications for all standby generators and related equipment shall be submitted to the DSM for prior approval.

All load banks shall conform to Section 16230 of the *DSM Specifications for Subdivisions and Sanitary Sewer Extensions*.

#### 12. POWER

If the ultimate pump power required is five (5) hp or more for an entire tributary area to a pumping station, then three phase electric power shall be supplied to the proposed pumping station. Four hundred and eighty (480) volt power is preferred. "Roto phase", "add a phase", or other devices to simulate three phase electric power are not acceptable.

One hundred ten (110) volt electric power shall be provided for lighting and instrumentation. Outlet plugs shall be ground fault type.

#### 13. ELECTRICAL

All electrical equipment, material, and installations shall meet the requirements of Division 16 of the *DSM Specifications for Subdivisions and Sanitary Sewer Extensions* and the *National Fire Protection Association (NFPA) 70-1993 (NEC)*. All electrical equipment, conduit, and electrical boxes installed inside wet well areas shall be explosion-proof and rated for Class 1, Division 1, Group D hazardous locations.



#### 14. CELLULAR TELEMETRY SYSTEM

Cellular Telemetry System shall meet the requirements of Section 16810 of the *DSM Specifications for Subdivisions and Sanitary Sewer Extensions*.

#### IX. RECORD DRAWINGS

Upon the completion of any project, one (1) set of Record Drawings on electronic media and one (1) full size paper copy will be required as specified below. Record Drawings must be submitted to the DSM prior to requesting a field walk of the subdivision or extension. The drawings must be certified by a professional engineer (PE) or a land surveyor (PLS) licensed in New York State, see Appendix "C". The drawings must be labeled as RECORD DRAWINGS showing the measured distance between manholes, as built rim and invert elevations of the manholes, and slope of the pipes between manholes. The DSM's requirements for record drawings are as follows:

- A. After a sewer is installed, tested, and before final acceptance, the developer/contractor shall provide at his expense one (1) set of record drawings on paper and in an electronic file format (CD or flash drive) compatible with the latest AutoCAD version. The pen assignment file (.CTB) should be included, along with any fonts used that are not regular AutoCAD fonts. A paper copy of the record drawings on 24" x 36" sheets should be submitted for review before sending the CD.
- B. Include a project location map with North arrow and include all external referenced drawings and images on the compact disc or bind them to the drawing.
- C. Include a map cover and sub-lot numbers, if applicable. Otherwise, all serviced buildings shall be labeled and/or numbered.
- D. Include City/Town/Village, Farm Lot, Township, Range and Section Numbers and show on the drawings where applicable.
- E. Use the invert elevation of the connection manhole as a vertical datum and include the contract name and number (or subdivision name) being connected to.
- F. Show the design and record elevations, distances, and slopes of pipe in a way easy to differentiate between the two.
- G. The drawings should clearly identify the phase of construction represented on the drawings.
- H. The DSM should be contacted for easement information (Liber and Page) to be included on the record drawings. Easement widths shown should agree with the easement documents. *See Section VI. above for widths.*
- I. The engineer's certification, signature, and seal that the record drawings are accurate are to be made in a cover letter identifying and transmitting the physical CD (see Appendix "C" for a sample certification letter).

- J. All Record Drawing submittals to the DSM must use Real Time Kinematic (RTK) technology utilizing a coordinate system in NAD 1983 State Plane New York West FIPS 3103 (feet). The GPS unit shall be a Trimble ProXR (or equal) providing sub-meter or better post-processed accuracy. The collected data shall be presented as an Excel Spreadsheet file, as points within an AutoCAD 2010 (or newer) file, as points within an ESRI shapefile or as a feature class inside an ESRI File Geodatabase. The contractor/developer shall deliver the data to the DSM in CD-ROM format.
- K. Acceptance of the Record Drawings will be subject to review and approval by the DSM.

X. ADDITIONAL REQUIREMENTS

These Design Requirements have been prepared to assist developers and design engineers in preparing subdivision and sanitary sewer extension plans. Only the highlights of the requirements have been presented. See the *Rules and Regulations for Erie County Sewer Districts*, *DSM Specifications for Subdivisions and Sanitary Sewer Extensions*, and the other references mentioned in the introduction for a complete description of the requirements.

**Design Engineers are encouraged to discuss preliminary sanitary sewer plans in advance of completing subdivision design.**

\* \* \*

Dated: 8-9-2024

## **APPENDIX A**

### **PROJECT REVIEW CHECKLISTS**

**CHECKLIST NO. A1: SUBDIVISIONS & SANITARY  
SEWER EXTENSION PROJECT  
REVIEW**

**CHECKLIST NO. A2: NON-RESIDENTIAL PROJECT  
REVIEW**

**CHECKLIST NO. A3: PUMPING STATION  
REQUIREMENTS**

## **APPENDIX A1**

### **CHECKLIST NO. A1: SUBDIVISIONS & SANITARY SEWER EXTENSION PROJECT REVIEW**

ERIE COUNTY DEPARTMENT OF ENVIRONMENT AND PLANNING  
DIVISION OF SEWERAGE MANAGEMENT  
CHECKLIST NO.A1: SUBDIVISION AND SANITARY SEWER EXTENSION PROJECT REVIEW

Project Name: \_\_\_\_\_ DSM File #: \_\_\_\_\_

City/Village/Town: \_\_\_\_\_ ECSD# \_\_\_\_\_ SR# \_\_\_\_\_ (ss)

**A. GENERAL DESIGN CRITERIA**

- |   | <u>INITIAL</u> | <u>FINAL</u> |
|---|----------------|--------------|
| 1. Record date submittal is received (transmittal letter required).   |                |              |
| 2. Is the project within an Erie County Sewer District?   |                |              |
| 3. Is there a sewer moratorium in effect for the area?  | NO             | NO           |
| 4. Is the project consistent with the Framework?  |                |              |
| 5. Can certification that sufficient capacity is available in the existing sanitary system be made for this proposed development? |                |              |
| 6. Does the submittal contain the following:  |                |              |
| a. 3 sets of Sanitary Sewer and Water Line Plans  |                |              |
| b. 3 sets of Engineer's Reports including downstream capacity analysis  |                |              |
| c. 2 Application Forms, 92-19-4   |                |              |
| d. 2 Project Data Forms, 92-15-8/(BMW-65)   |                |              |
| e. 2 sets of Map Covers   |                |              |
| f. 2 sets of Pavement & Drainage Plans  |                |              |
| g. 2 sets of Lot Grading Plans  |                |              |
| h. EAF Form or SEQRA Determination  |                |              |
| 7. If there is a pumping station, is it the only alternative?   |                |              |
| a. If yes, does the pumping station serve a minimum of 50 single family homes, or equal?  |                |              |
| b. Is the pumping station sized to service the entire tributary area?   |                |              |
| 8. Record date submittal is complete and distributed to the district and the Erie County Health Department:                       |                |              |

(Design Engineers are encouraged to discuss preliminary sanitary sewer plans in advance of completing subdivision design.)

**B. SPECIFIC DESIGN CRITERIA**

	<u>INITIAL</u>	<u>FINAL</u>
1. Have District comments been received?		
2. Are the following stamped and signed by a Professional Engineer licensed to practice in New York State:		
a. Sanitary Sewer Plans		
b. Application 92-19-4		
c. Project Data Forms 92-15-8 (BMW-65)		
d. Engineer's Report		
3. Is there a Location Map on the Plans?		
4. Is each lot numbered and served?		
6. Is the proposed sewer size sufficient for future needs of the district?		
6. Can adjacent properties be served in the future?		
7. Are sewers designed in a straight alignment?		
8. Are far side laterals for each lot provided?		
9. Are utilities separated?		
10. a. Are the sewer size, material, slope, and distance between manholes noted on both Plan and Profile?		
b. Is there a grid shown on the profile with 5' interval elevations and 50' interval baseline stations?		
11. Is each manhole numbered, showing rim and invert elevations?		
12. a. Where possible, are sewer lines designed at a minimum nominal depth of eight (8') feet?		
b. Where sewers are deeper than eight (8') feet, are risers shown for each lot?		
13. Are manholes located on common lot lines, or if this is not feasible, at the lot midpoint, and outside of sidewalk areas?		
14. Are end of line (deadend) manholes located at upstream lots, capped with stubs for future extension?		
15. Have velocity head losses been compensated for by invert drops for changes in flow direction less than or equal to 90 degrees?		

B. SPECIFIC DESIGN CRITERIA (continued)

	INITIAL	FINAL
16. At manholes where different diameter sewers intersect, are the sewers 0.8 depth point at the same elevation?		
17. Are inside drop manholes provided where invert elevations exceed two (2') feet? (Outside drop is not acceptable, see Detail #18)		
18. Is the difference in manhole inlet/outlet invert elevations a maximum of 0.3' for pipes of equal diameter?		
19. For reduction in slope, have compensating drops in inverts been provided?		
20. Is the distance between manholes less than or equal to 400 feet?		
21. Where lamp holes are proposed for end of line extensions, are they <u>not</u> in excess of 150-feet from the last manhole?		
22. Do all six (6") inch building sewers connect to the sanitary sewer and not to manholes?		
23. Are all road crossings hatch marked and designated "Select Fill Required"?		
24. Are road crossings with less than four (4') feet of cover labeled "Concrete Encasement Required"?		
25. Are waterline, storm sewer, and all other utility crossings shown on the profile?		
26. Are waterline crossing clearances at a minimum of 18-inches, or if closer, waterline type sewer construction provided?		
27. Are waterline relation to sewer notes shown ( <i>Sec. 38.3 of Ten State Standards, latest edition</i> )?		
28. Where fill is needed, is it noted to be satisfactorily installed and compacted prior to sewer installation?		
29. Is a note specifying that construction is to conform to Erie County Sewer District Rules and Regulations shown?		
30. Are DSM Standard Details shown?		

**B. SPECIFIC DESIGN CRITERIA (continued)**

INITIAL	FINAL
---------	-------

31. Are the DSM General Notes shown?

32. Is the location of the Permanent Subdivision sign shown?

33. Are standard notes on testing and acceptance shown (hydrostatic, air and deflection)?

34. Has the owner of each parcel of the proposed project been identified?

SBL# \_\_\_\_\_

SBL# \_\_\_\_\_

35. **A.** If there is an existing public sewer within the project.

Do we have a filed easement? If not it's time to obtain.

**B.** Are proposed easements shown as follows:

<u>Sewer Depth/Location</u>	<u>Total width of Easement (Centered on Sewer Line)</u>
0 - 11'	twenty (20') feet
Over 11' but less than 18'	thirty (30') feet
Sewers around Cul-de-sacs	thirty (30') feet
Back or common lot lines	thirty (30') feet
Over 18'	case by case basis

Frontage easements are to provide the distance from the centerline required above, rounded upward to the nearest five (5') foot increment.

36. Where a pumping station is proposed, has Checklist No. A3: Pumping Station Requirements been satisfactorily completed?

37. Where a pumping station is proposed, is the title for the parcel shown, deeded fee simple to the County of Erie (actual transfer of ownership will occur after accepting the pumping station)?

38. Have the easement forms and capital gains tax affidavits, signed by the owner for each parcel, and the easement map, been received?

39. Do we have a letter from the Developer agreeing to complete the required number of building sewers to meet the I/I remedial work? \_\_\_\_\_



Note: Any "NO" answer (except for A.3) is to be resolved prior to submitting the plans to the Department of Health for approval. Deviations from standards are to be justified in writing and supported by DSM.

Reviewed by: \_\_\_\_\_ Date: \_\_\_\_\_

C. DSM APPROVAL

When the General and Specific Design Criteria Reviews are complete and all questions on the project are resolved to the DSM's satisfaction and all the pertinent documents are provided, including the completion of the checklist below, the application (Form No. 92-19-4) will be accepted and signed by the DSM.

1. Has the ECSD field staff reviewed the plans?

District Representative: \_\_\_\_\_ Date: \_\_\_\_\_

2. Is there a signed standard easement document, a capital gains tax affidavit, and an easement map ready to be filed?

\_\_\_\_\_

3. Is there a signed confirmation letter from the Owner/Developer agreeing to the I/I remedial work schedule?

Owner/Developer: \_\_\_\_\_ Date: \_\_\_\_\_

4. Is the Checklist satisfactorily completed?

Signature: \_\_\_\_\_ Date: \_\_\_\_\_

Sr. Coordinator Sewer Construction Projects

8/16/2024

## **APPENDIX A2**

### **CHECKLIST NO. A2: NON-RESIDENTIAL PROJECT REVIEW**

ERIE COUNTY DEPARTMENT OF ENVIRONMENT AND PLANNING  
DIVISION OF SEWERAGE MANAGEMENT  
CHECKLIST NO. A2: NON – RESIDENTIAL PROJECT REVIEW

Project Name: \_\_\_\_\_ CP#: \_\_\_\_\_

City/Village/Town: \_\_\_\_\_ ECSD#: \_\_\_\_\_

SBL#: \_\_\_\_\_ I/I requirement (if applicable): \_\_\_\_\_

<u>A. GENERAL DESIGN CRITERIA</u>	INITIAL	FINAL
1. Record date submittal is received (transmittal letter required)		
2. Is the project within an ECSD or tributary to a DSM treatment plant? (If not inform the submitter that DSM does not review)		
3. Does the submittal contain the following:		
a. 2 sets of Sanitary Sewer and Water Line Plans		
b. 1 set of Interior Plumbing Plans		
c. 1 Industrial Waste Survey signed by the owner (N/A for residential projects)		
d. 1 set of Pavement & Draining plans (if applicable)		
e. 1 Grease Trap Sizing Calculations (if applicable) 7.5 x # of Meals per Day = Gallons required (min 750)		
4. Is there sufficient capacity available in the existing sanitary sewer system to accommodate this proposed development?		
a. If a downstream capacity analysis is required (total average daily flow > 2500 GPD) has it been certified by the engineer and approved by DSM?		
5. Is there an existing sanitary sewer fronting the parcel? (If not, a sanitary sewer extension must be applied for)		
6. Does the proposed connection point make the most sense of all possible alternatives?		

7. Are all building sewers six inches (6") in diameter?

--	--

8. Is record date submittal complete and distributed to the district?

INITIAL	FINAL

**B. SPECIFIC DESIGN CRITERIA**

1. Have District comments been received? (Must be "yes" prior to sending comments to engineer)

--	--

2. Is there a clear Location Map on the Plans that shows the parcel and the surrounding streets?

--	--

3 A. If there is an existing public sewer within the project; Do we have a filed easement? If not it's time to obtain.

--	--

B. Have the easement forms, capital gains tax affidavits and easement maps been received? (if required)

--	--

4 If there is an existing tap to be abandoned, is it shown on the plans?

--	--

5 Is a separate building sewer provided for each building?

--	--

6 Do all six-inch (6") building sewers connect to the sanitary sewer and not to manholes?

--	--

7 Is the building sewer perpendicular to the existing sanitary sewer with a wye or saddle connection?

--	--

8 Have ALL requirements of Detail No.22 been met?

--	--

a. Is the grade of the sewer at least 1%?

--	--

b. Is there a vent and trap outside the building?

--	--

c. Are there cleanouts every 100 feet or change of direction?

--	--

d. Is select backfill matchmarked and noted under paved areas?

--	--

e. Are cleanouts and vents installed in lawn areas, preferably between the curb or edge of pavement and the sidewalk?

--	--

f. Does the sewer have 3 feet of cover?

--	--

--	--

9	Is the sewer profile shown for all proposed sewers?		
10	Are waterline, storm sewer, and all other utility crossings shown on the profile?		
11	Are fill areas labeled "Fill shall be installed and satisfactorily compacted prior to the installation of the sewer lines"?		
		INITIAL	FINAL
12	If a grease trap is required:		
	a. Is it properly sized?		
	b. Is the size (gallons) and type of grease trap noted on both Plan and Profile?		
	c. Are only food preparation areas including kitchen sinks, bar sinks, and floor drains from kitchens and other food preparation areas attached to the grease trap line?		
	d. Is sediment trap/grease trap detail #29 included?		
	e. If a sediment trap is required (vehicle maintenance/washing) is it shown on the plans?		
13	Are notes pertaining to other required permits (DOT, ECDPW etc.) included?		
14	Are DSM General Notes A-I shown?		
15	Is a note specifying that construction is to conform to Erie County Sewer District Rules and regulations shown?		
16	Are applicable DSM Standard Details shown?		

All questions must be answered with YES or N/A prior to final approval.

Reviewed By: \_\_\_\_\_ Date: \_\_\_\_\_

Design Engineers are encouraged to discuss preliminary sewer plans in advance of completing project design.

C. DSM APPROVAL

When the General and Specific Design Criteria Reviews are complete and all questions on the proposed project are resolved to the DSM's satisfaction, the Sr. Coord. Sewer Construction Projects will review the completeness of the following checklist, and then issue the approval.

3. Has the ECSD field staff reviewed the plans?

District Representative: \_\_\_\_\_ Date: \_\_\_\_\_

2. Is there a signed standard easement document and capital gains tax affidavit, and an easement map ready to be filed?

\_\_\_\_\_

3. If required, is there a signed confirmation letter from the Owner/Developer agreeing to the I/I remedial work schedule?

Owner/Developer: \_\_\_\_\_ Date: \_\_\_\_\_

4. Is the checklist satisfactorily completed? \_\_\_\_\_

Signature: \_\_\_\_\_ Date: \_\_\_\_\_  
Sr. Coordinator Sewer Construction Projects

8/16/2024

## APPENDIX A3

### **CHECKLIST NO. A3: PUMPING STATION REQUIREMENTS**

ERIE COUNTY DEPARTMENT OF ENVIRONMENT AND PLANNING  
DIVISION OF SEWERAGE MANAGEMENT  
CHECKLIST NO.A3: PUMPING STATION REQUIREMENTS

Project Name: \_\_\_\_\_ DSM File# \_\_\_\_\_

City/Village/Town: \_\_\_\_\_ ECSD# \_\_\_\_\_ SR# \_\_\_\_\_ (ss)

A. SITE LAYOUT

INITIAL                      FINAL

1. Area and Title provided
2. Building type and sizes are shown
3. Sidewalk, Approach Apron & Driveway
4. Unpaved Areas in Pumping Station Site
5. Water Supply & Hose Bib including approved RPZ
6. Perimeter Fence and Gate
7. Drainage

	<u>INITIAL</u>	<u>FINAL</u>

B. FORCE MAIN:

1. Size and Marker
2. Air Release Valves

C. PUMP CHAMBER: Size, Depth, Buoyancy & Storage

--	--	--

D. VALVE CHAMBER: Bypass Pump Around

\_\_\_\_\_

--	--	--

E. PRESSURE GAUGE

--	--	--

F. COMMUNICATOR

--	--	--

G. PUMPS

1. Rate (gpm)
2. HP
3. Pump on/off (Elev.)
4. High Wetwell Alarm (elev.)
5. Spare Pump Provided
6. Parts Provided

H. CONTROL PANEL (Explosion proof)

--	--	--

I. GENERATOR SET AND FUEL TANK

--	--	--

J. AUTOMATIC TRANSFER SWITCH

--	--	--

K. LOAD BANK

--	--	--



L. POWER (3 phase) \_\_\_\_\_

M. MOTORIZED LOUVERS (metal hinges) \_\_\_\_\_

N. TELEMETRY SYSTEM/Cellular (Type) \_\_\_\_\_

O. O&M MANUAL (Electronic format) \_\_\_\_\_

District Reviewer \_\_\_\_\_ Date \_\_\_\_\_

DSM Review: \_\_\_\_\_ Date: \_\_\_\_\_

P. Parcel Deed Filed \_\_\_ L. \_\_\_\_\_, P. \_\_\_\_\_ Date: \_\_\_\_\_

Q. UPON COMPLETION & PRIOR TO CERTIFICATION – for public pumping stations

	<u>YES</u>	<u>NO</u>
1. Three-day test completed and passed.	_____	_____
2. Spare pump and parts are provided to the district.	_____	_____
3. OMNISITE:		
a. CTU activation fee is paid.	_____	_____
b. Monthly monitoring for the first 3 years is paid for in full.	_____	_____
4. Electric service turned over to County.	_____	_____
5. Water service turned over to County.	_____	_____
6. As Built shown on Record Drawings	_____	_____

BY: \_\_\_\_\_

DATE \_\_\_\_\_

NAME: \_\_\_\_\_

TITLE: \_\_\_\_\_

8/16/2024

## **APPENDIX B**

### **B – 1 NOTES FOR SUBDIVISIONS AND SANITARY SEWER EXTENSIONS**

### **B – 2 NOTES FOR NON-RESIDENTIAL PROJECTS**

**APPENDIX B – 1**

**NOTES FOR  
SUBDIVISIONS  
AND  
SANITARY SEWER EXTENSIONS  
WITHIN  
ERIE COUNTY SEWER DISTRICTS**

GENERAL NOTES FOR  
SANITARY SEWER CONSTRUCTION  
WITHIN ERIE COUNTY SEWER DISTRICTS

1. The Erie County Division of Sewerage Management (DSM), who operates and maintains the existing sewer lines and appurtenances within Erie County Sewer Districts (ECSD), is to be notified at least 48 hours in advance of the start of construction.
2. Construction shall be in accordance with the Rules and Regulations for Erie County Sewer Districts.
3. All permits required by the Federal, State, County, City and/or Town governments to perform work must be obtained prior to the start of work and paid for by the Contractor.
4. If easement and/or Out of District Agreements are required, they must be complete and ready to be filed before the project will be approved for construction.
5. The contractor shall comply in all respects to the Industrial Code Part (Rule No.) 53 relating to construction, excavation, and demolition operations at or near underground facilities, as issued by the State of New York Department of Labor, Board of Standard and Appeals.
6. The construction of the sanitary sewer facilities shall be under the supervision of a person or firm qualified to practice professional engineering in New York State under the Education Law of the State, whenever engineering services are required by such law for such purposes.
7. Where such sanitary sewer facilities are under the supervision of a professional engineer, he/she shall certify to the DSM and to the applicant that the constructed facilities have been under his/her supervision and that the work has been fully completed in accordance with the approved engineering reports, plans, specifications, and approvals.
8. The Contractor is solely responsible for all site safety. The Contractor's equipment and methods of operation shall be in full compliance with OSHA Standards and satisfy all Federal, State and Local Health and Safety Regulations.
9. The Contractor is advised a trench shield and/or shoring designed in accordance with OSHA Standards shall be used in all open trench excavations.
10. Any contractor and/or plumber performing work in a confined space (i.e. manholes, wetwells, and chambers) owned by an Erie County Sewer District, must certify to the County that they have their own Confined Space Entry Program that meets or exceeds OSHA's regulations. Certification must be notarized by a notary public.

11. The contractor shall expose existing utilities ahead of the pipe laying operation, so if minor adjustments must be made in the pipe elevation and/or alignment due to interference from these utilities, said changes can be made in advance of the work.
12. The contractor shall retain the services of a qualified tree expert to remove, where necessary, branches which interfere with the construction operation, or to repair trees having suffered damage by construction activities. The cost involved is to be included in the various items of the contract.
13. The proposed 8 through 12-inch diameter sanitary sewer pipe shall be polyvinyl chloride (PVC) sewer pipe conforming to the latest revisions of American Society for Testing and Materials (ASTM) designation D-3034, SDR-35, installed in accordance with the ASTM designation D-2321-83a or the latest revision thereof, or approved equal. Larger diameter pipes will be reviewed on a case-by-case basis.
14. Sewers shall be laid with straight alignment between manholes and shall be checked by using a laser beam or lamping.
15. Should a fluid condition be encountered at the trench bottom, the contractor is to undercut the trench and provide suitable fill material (stone & fabric) to stabilize the trench bottom.
16. Sanitary sewer bedding material shall be No. 1 crushed stone with a gradation conforming to the *DSM Specifications for Subdivisions and Sanitary Sewer Extensions*.
17. Backfill shall be of a suitable material removed from the excavation except where other material is specified. Debris, frozen material, large clods or stones, organic matter, or other unstable materials shall not be used for backfilling within two (2') feet of the top of the pipe.
18. All pipes crossing under paved areas are to be backfilled to sub-grade with compacted select material (No. 2 crushed stone) to five (5') feet outside the pavement edges or as required by the highway permit. If any proposed sewer runs under paved areas and has less than four (4) feet of cover, then concrete encasement is required as shown on the DSM Typical Concrete Encasement Detail.
19. Sewers parallel to watermains - *Ten State Standards, Latest Edition, Chapter 30, Section 38.31, and Page 30-11*: Sewers shall be laid at least ten (10') feet (three (3) meters) horizontally from any existing or proposed water main. The distance shall be measured edge to edge. In cases where it is not practical to maintain a ten (10') foot separation, the appropriate reviewing agency may allow deviation on a case-by-case basis, if supported by data from the design engineer. Such deviation may allow installation of the sewer closer to a water main, provided that the water main is in a separate trench or on an undisturbed earth shelf located on one side of the sewer and at an elevation, so the bottom of the water main is at least 18-inches (460 mm) above the top of the sewer.

If it is impossible to obtain proper horizontal and vertical separation as described above, both the water main and sewer must be constructed of slip-on or mechanical joint pipe complying with public water supply design standards of the regulatory agency and be pressure tested to 150 pounds per square inch (psi) (1034 kPa) to assure water tightness prior to backfilling.

20. Sewers crossing watermains - *Ten State Standards, Latest Edition, Chapter 30, Section 38.32, Page 30-11 to 30-12*: Sewers crossing water mains shall be laid to provide a minimum vertical distance of 18-inches (460 mm) between the outside of the water main and the outside of the sewer. This shall be the case where the water main is either above or below the sewer. The crossing shall be arranged so that the sewer joints will be equidistant and as far as possible from the water main joints. Where a water main crosses under a sewer, adequate structural support shall be provided for the sewer to maintain line and grade.
21. When it is impossible to obtain proper horizontal and vertical separation as stipulated above, one of the following methods must be specified:
  - a. The sewer shall be designed and constructed equal to water pipe and shall be pressure tested at 150 psi (1034 kPa) to assure water tightness prior to backfilling.
  - b. Either the water main or the sewer line may be encased in a watertight carrier pipe which extends ten (10') feet (three (3) meters) on both sides of the crossing, measured perpendicular to the water main. The carrier pipe shall be of materials approved by the regulatory agency for use in water main construction.
  - c. The sewer shall be encased in concrete per the DSM Watermain Crossing Detail Typical for Encasement
22. The manhole covers are to bear the inscription "ECSD SANITARY" and comply with the DSM Standard Frame and Cover detail. For private projects the covers shall bear the inscription "SANITARY SEWER" and comply with the DSM Standard Frame and Cover (Private Sewer) detail.
23. Building sanitary sewer vents must be installed six (6) inches above finished grade in a grassy area with a mushroom cap. If the vent is in a sidewalk or paved area, then protect with 6" diameter bollards (2 minimum).
24. Cleanouts (c.o.) are required on 4" and 6" building sewers every fifty feet and one hundred feet respectively, and at every change of alignment.
25. Abandoned building sewer connections from the site, if any, require proof of a District Permit for Disconnection prior to the new connection being made.
26. The following pertains only for direct replacement of in-service sanitary sewers:
  - a. Each new pipe joint shall be ultrasonic tested after it is laid, but before the next pipe is laid. All tests shall be in accordance with the testing equipment manufacture recommendations.

- b. The ultrasonic test shall be performed in lieu of the hydrostatic and air tests.
  - c. A video inspection of the entire sewer shall be performed. Forward the video inspection tape and related paperwork to DSM for review and approval.
  - d. A deflection test is required in all cases.
27. For all sanitary sewer installations, a written certificate of construction completeness and compliance, including the results of the hydrostatic leakage test, deflection test and air test, etc. shall be submitted to the Erie County Health Department and DSM within thirty (30) days after completion of construction.
28. For all public and private, the developer/contractor must provide one (1) set of record drawings as described in Article on "D" size paper (24" x 36") and in an electronic file X of the Design Requirements.
29. All public sewer extension projects that consist of more than 750 LF of 8" diameter pipe or larger, shall furnish a 2-year maintenance bond to the DSM.
30. Final Certification will be issued upon the full completeness and compliance of the project including any requirement(s) of I&I remedial work.
32. For pumping stations, a three-day test is required.
33. For public pumping stations, Spare pump and parts shall be provided to the district by the developer/contractor.
34. For pumping station's monitoring by OMNISITE, the developer/contractor shall pay the CTU activation fee, and the monthly monitoring fee for the first 3 years.
35. For public pumping stations, the electric and water services shall be turned over to County.

DATED: 8/16/2024

**APPENDIX B – 2**

**GENERAL NOTES**  
**NON-RESIDENTIAL**  
**PROJECTS**



## NOTES REQUIRED ON PLANS

- A. “The contractor is advised a trench shield and/or shoring designed in accordance with OSHA Standards shall be used in all open trench excavations”.
- B. “Any contractor and/or plumber performing work in a confined space (i.e. manholes, wetwells, chambers) owned by an Erie County Sewer District, must certify to the County that they have their own Confined Space Entry Program that meets or exceeds OSHA’s regulations. Certification must be notarized by a notary public”.
- C. “Construction shall conform to the Rules and Regulations for Erie County Sewer Districts”.
- D. If any proposed sewer lateral runs under paved area and has **less** than four (4) feet of cover, then concrete encasement is required. Attach Detail No. 6 to plans. On site plan and profile hatchmark and/or label “concrete encasement” in affected areas.

Or

If any proposed sewer lateral runs under paved area and has **more** than four (4) feet of cover, then on site plan and profile hatchmark and label, “select fill required” in affected areas.
- E. The contractor must contact the District Office 48 hours in advance of construction.
- F. Vents must be installed six (6) inches above grade, in a grassy area with a mushroom cap. If the vent is in a sidewalk or paved area, then protect with bollards (3 minimum).
- G. Cleanouts (c.o) are required every one hundred feet (100’) and at change of direction.
- H. Abandoned sanitary sewer connections from the site, if any, require proof of a District Permit for Disconnection prior to the new connection being made.
- I. Reuse of existing building sewers shall conform to the Rules and Regulations for ECSD, Article III, Section 304.

DATED: 8/16/2024

## **APPENDIX C**

### **RECORD DRAWING SUBMITTAL SAMPLE CERTIFICATION LETTER**

Erie County Division of Sewerage Management  
95 Franklin Street, Room 1034  
Buffalo, New York 14202-3973

RE: Erie County Sewer District No. \_\_\_\_\_

To Whom It May Concern:

The \_\_\_\_\_  
NAME OF CONSULTING AND/OR CERTIFYING ENGINEER / SURVEYOR

License No. \_\_\_\_\_ certifies that the information contained on the  
attached CD or flash drive and saved as \_\_\_\_\_ reflects the record  
drawings of \_\_\_\_\_  
FILE NAME

\_\_\_\_\_ as of \_\_\_\_\_.  
PROJECT NAME DATE

No alteration to this record drawing file can be made except as permitted by Section  
7209, Subdivision 2 of the New York State Education Law.

This project was designed by \_\_\_\_\_.  
FIRM'S NAME

If you have any questions, please contact me at \_\_\_\_\_  
PHONE

or \_\_\_\_\_.  
E-MAIL

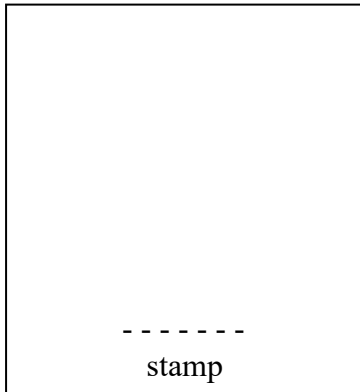

Very truly yours,

\_\_\_\_\_  
NAME (TYPE OR PRINT)

\_\_\_\_\_  
TITLE

\_\_\_\_\_  
STAMP AND SIGNATURE

File: \_\_.2.5. Subdivision

**APPENDIX D**

**STANDARD DETAILS**

# ERIE COUNTY SEWER DISTRICTS

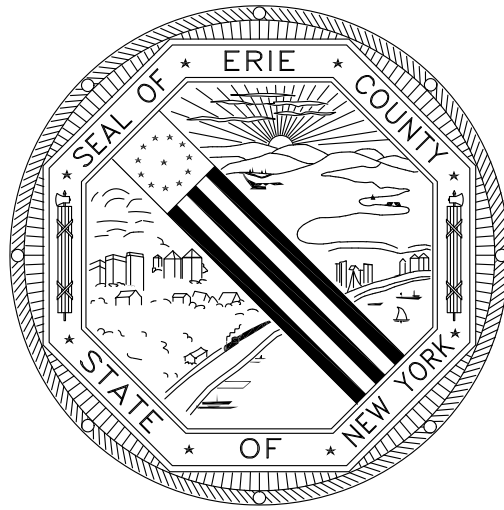

## STANDARD DETAILS

NOVEMBER 2023

# DETAIL INDEX SHEET

(NOVEMBER 2023)

<u>STANDARD DETAIL NO.</u>	<u>FILE NAME</u>	<u>24x36 SHEET</u>	<u>DESCRIPTION</u>
1	D-01	D-1	UNSHEETED TRENCH DETAIL
1a	D-01a	D-1	TRENCHING "UNDERCUT" DETAIL
2	D-02	D-1	SHEETED TRENCH DETAIL
3	D-03	D-1	ROCK TRENCH DETAIL
4	D-04	D-1	SELECT BACKFILL FOR TRENCH PARALLEL TO ROADWAYS
5	D-05	D-1	WATER MAIN CROSSING DETAIL (TYPICAL FOR ENCASEMENT)
6	D-06	D-1 & CD-1	TYPICAL CONCRETE ENCASEMENT
7	D-07	D-1	CONCRETE CRADLE DETAIL
8	D-08	D-1	PAVEMENT AND DRIVEWAY REPLACEMENT DETAIL
9	D-09	D-1	PIPE CROSSING SUPPORT DETAIL
10	D-10	D-2	MONOLITHIC PRECAST BASE MANHOLES, 4'-0" DIA. BASE FOR 15"Ø SEWERS OR LESS
11	D-11	D-2	MONOLITHIC PRECAST BASE MANHOLES, 4'-0" DIA. BASE FOR 15"Ø SEWERS OR LESS (SECTION B-B)
11a	D-11a	8.5x11 only	MONOLITHIC PRECAST BASE MANHOLES, 4'-0" DIA. BASE FOR 15"Ø SEWERS OR LESS (SECTION B-B) SUBDIVISIONS & PRIVATE EXTENSIONS
12	D-12	D-2	MONOLITHIC PRECAST BASE MANHOLES FOR PIPE SIZES 18" THRU 36"Ø
12a	D-12a	8.5x11 only	MONOLITHIC PRECAST BASE MANHOLES FOR PIPE SIZES 18" THRU 36"Ø SUBDIVISIONS & PRIVATE EXTENSIONS
13	D-13	D-3	STD FRAME AND COVER (8"Ø PIPE & UP)
13P	D-13P	8.5x11 only	STD FRAME AND COVER (Private Sewer)
14	D-14	D-1 & PS-2	FORCE MAIN TRENCH DETAIL
15	D-15	D-2	FLAT TOP DETAIL
16	D-16	D-3	WATER TIGHT FRAME AND COVER
17	D-17	D-2	STANDARD MANHOLE STEP
18	D-18	D-2	INSIDE DROP PIPE
19	D-19	D-2	MANHOLE VENT DETAIL
20	D-20	D-4	TREE REMOVAL AND REPLACEMENT POLICY
21	D-21	8.5x11 only	TYPICAL HOUSE SERVICE DETAIL
21a	D-21a	8.5x11 only	TYPICAL HOUSE SERVICE REPAIR DETAIL
22	D-22	CD-1	TYPICAL COMMERCIAL SERVICE WITHOUT BASEMENT
22a	D-22a	8.5x11 only	TYPICAL COMMERCIAL SERVICE WITHOUT BASEMENT DETAIL VENT CAP/RISER IN PAVEMENT

# DETAIL INDEX SHEET

PAGE 2 OF 3

(NOVEMBER 2023)

STANDARD DETAIL NO.	FILE	24x36 SHEET	DESCRIPTION
22b	D-22b	8.5x11 only	TYPICAL COMMERCIAL SERVICE WITH BASEMENT
21&22B	D-21&22B	8.5x11 ?	TAP SADDLE INSTALL ON CIPPL PIPES
23	D-23	D-3	CONSTRUCTION SPECIFICATIONS FOR HSE LATERALS
24	D-24	D-3 & CD-1	TYPICAL CROSS SECTION OF HIGHWAY CROSSING FOR HOUSE/COMMERCIAL LATERALS
25	D-25	D-4	ROAD CROSSING BY JACKING AND BORING METHOD - 6" TO 24" CARRIER PIPE
26	D-26	D-3	CAP & BLOCKING METHODS FOR AIR TEST
27	D-27	D-3 & CD-1	RISER DETAIL - SDR-35 MAIN LINE LATERAL CONNECTION
27a	D-27a	8.5x11 only	RISER DETAIL C-900 MAIN LINE LATERAL CONNECTION
28	D-28	D-3 & CD-1	CLEAN-OUT DETAIL FOR SERVICE CONNECTION
29	D-29	CD-1	SEDIMENT TRAP/GREASE TRAP DETAIL
30	D-30	8.5x11 only	SIMPLEX OR DUPLEX LOW PRESSURE GRINDER PUMP
31	D-31	8.5x11 only	TYPICAL HOUSE ELECTRIC SERVICE CONNECTION
32	D-32	8.5x11 only	TYPICAL FORCE MAIN SERVICE CONNECTION
32a	D-32a	8.5x11 only	GRINDER PUMP FORCE MAIN CONNECTION TO GRAVITY SEWER LINE
33	D-33	D-3	SANITARY SEWER PIPE & MH ABANDONMENT
34	D-34	8.5x11 only	TYP. HSE. CONNECTION/ABANDONMENT DETAIL
35	D-35	D-2	PRECAST DOGHOUSE BASE MANHOLE
36	D-36	PS-2	TYPICAL FORCEMAIN MANHOLE
37	D-37	D-2	CONNECTION TO EXISTING MANHOLE
38	D-38	PS-2	PUMP STATION "A"
39	D-39	PS-2	TYPICAL PUMP STATION "A" BLDG. LAYOUT
40	D-40	PS-2	TYPICAL PUMP STATION "B"
41	D-41	PS-2	TYPICAL PUMP STATION "B" BLDG. LAYOUT
42	D-42	PS-1	WETWELL - VALVE CHAMBER / TOP VIEW
43	D-43	PS-1	WETWELL - VALVE CHAMBER / SECTION
44	D-44	PS-1	WETWELL / SIDE VIEW
45	D-45	PS-1	WETWELL JUNCTION BOX
46	D-46	PS-1	WETWELL / VALVE CHAMBER DETAILS
47	D-47	PS-1	GUAGE DETAIL
48	D-48	PS-1	PUMP CABLE GRIP HOLDER
49	D-49	PS-2	SEWER AIR RELEASE VALVE & MANHOLE
50	D-50	D-4	ROUND CONCRETE PIPE STEEL RING JOINT DETAIL

DETAIL INDEX SHEET  
(NOVEMBER 2023)

<u>STANDARD DETAIL NO.</u>	<u>FILE</u>	<u>24x36 SHEET</u>	<u>DESCRIPTION</u>
51	D-51	D-4 & PS-2	FORCE MAIN MARKER
52	D-52	D-4 & CD-1	EXISTING CLEANOUT REMOVAL
53	D-53	CD-1	CLEANOUT IN PAVEMENT/SIDEWALKS NON RESIDENTIAL AND COMMERCIAL PROJECTS
54	D-54	D-4 & CD-1	CLEANOUT DETAIL END OF LINE (NEW CONSTRUCTION)
55	D-55	D-3	CLAY DAM RELIEF PIPE
56	D-56	D-4	STEEP SLOPE SANITARY SEWER PROTECTION CONCRETE ANCHOR COLLAR DETAIL
57	D-57	D-4 & PS-2	FORCEMAIN THRUST BLOCK DETAIL



# TRENCHING "UNDERCUT" DETAIL

(NOVEMBER 2023)

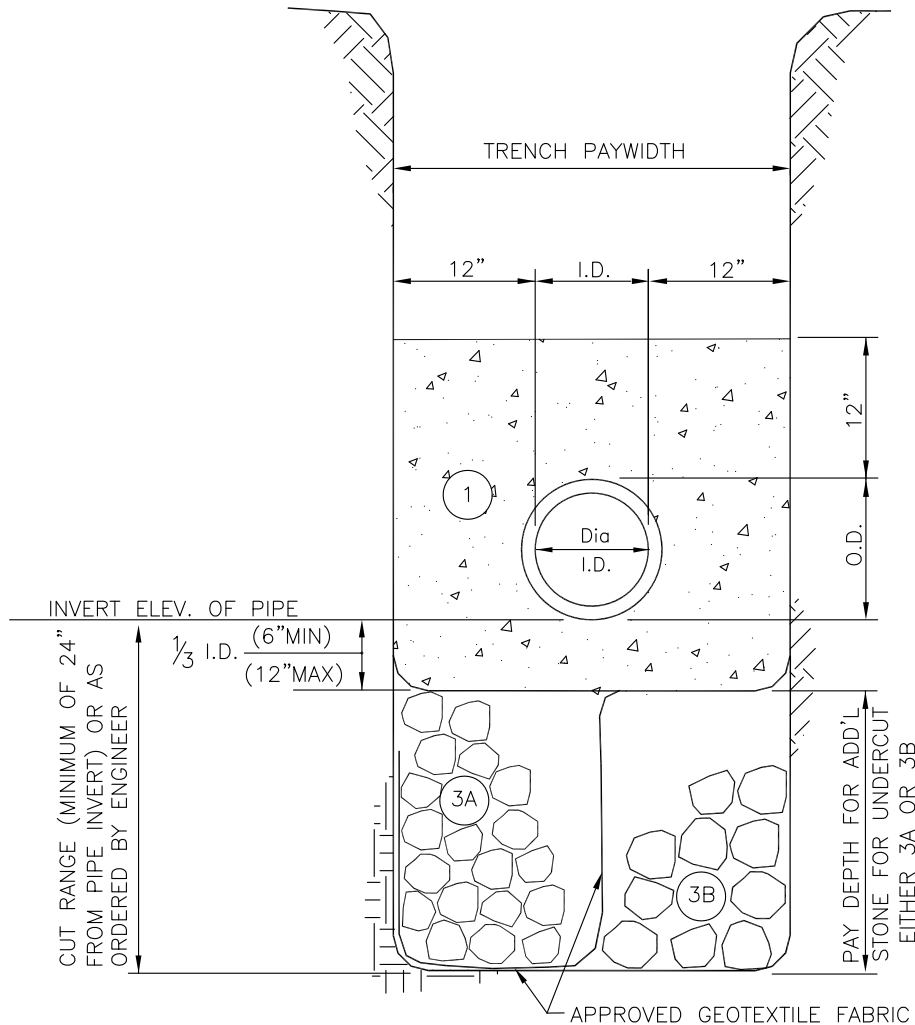

**NOTE:**

- A. TRENCH DETAILS ARE ONLY SHOWN FOR PURPOSES OF MATERIAL PLACEMENT AND MAXIMUM PAY LIMITS.
- B. AN OSHA APPROVED MOVABLE PROTECTIVE TRENCH SHIELD SHALL BE USED IN ALL UNSHEETED TRENCH AREAS.

**MATERIALS**

**PIPE BEDDING MATERIAL (NYS DOT LATEST EDITION)**

- ① NO. 1 CRUSHED STONE WITH A GRADATION CONFORMING WITH NYSDOT SECTION 703-02. THE CRUSHED STONE SHALL BE WELL GRADED WITH NO PARTICLES LARGER THAN 1" AND HAVING A MAXIMUM GRADATION MEETING THE LIMITS DESCRIBED IN THE SPECIFICATIONS. THE BEDDING SHALL BE COMPACTED IN 6" LIFTS WITH EQUIPMENT ACCEPTABLE TO THE PIPE MANUFACTURER.

**SELECT MATERIAL BACKFILL (NYS DOT LATEST EDITION)**

- ③A NO. 3 RUN OF CRUSHER STONE WITH A GRADATION CONFORMING WITH NYSDOT SECTION 304-2.02 TYPE 1 AND NYSDOT SECTION 703-02. COMPACTED IN 6" LIFTS WITH APPROVED GEOTEXTILE FABRIC.

OR

- ③B NO. 4 RUN OF CRUSHER STONE CONFORMING WITH THE GRADATION NOTED IN NYSDOT SECTION 703-02, TABLE 703-4 SIZE DESIGNATION 4.

NO SLAG SHALL BE ALLOWED FOR MATERIALS ① ③A & ③B

File: V:\DSM\Engineering\CAD\Details\November 2023\0-01a.dwg, Last saved: 12/11/2023, Plot Date: 12/11/2023, Plot Style: DETAILS.CTB

**ERIE COUNTY  
DEPT. OF ENVIRONMENT & PLANNING  
DIVISION OF SEWERAGE MANAGEMENT**

Rev. 1	ADDED SELECT FILL
12/2001	MATERIAL 3A & 3B

Rev. 2

File: D-01a

Date: 3/2/99

STD.DETAIL

1 A

# UNSHEETED TRENCH DETAIL FOR SPOT REPAIRS (NOVEMBER 2023)

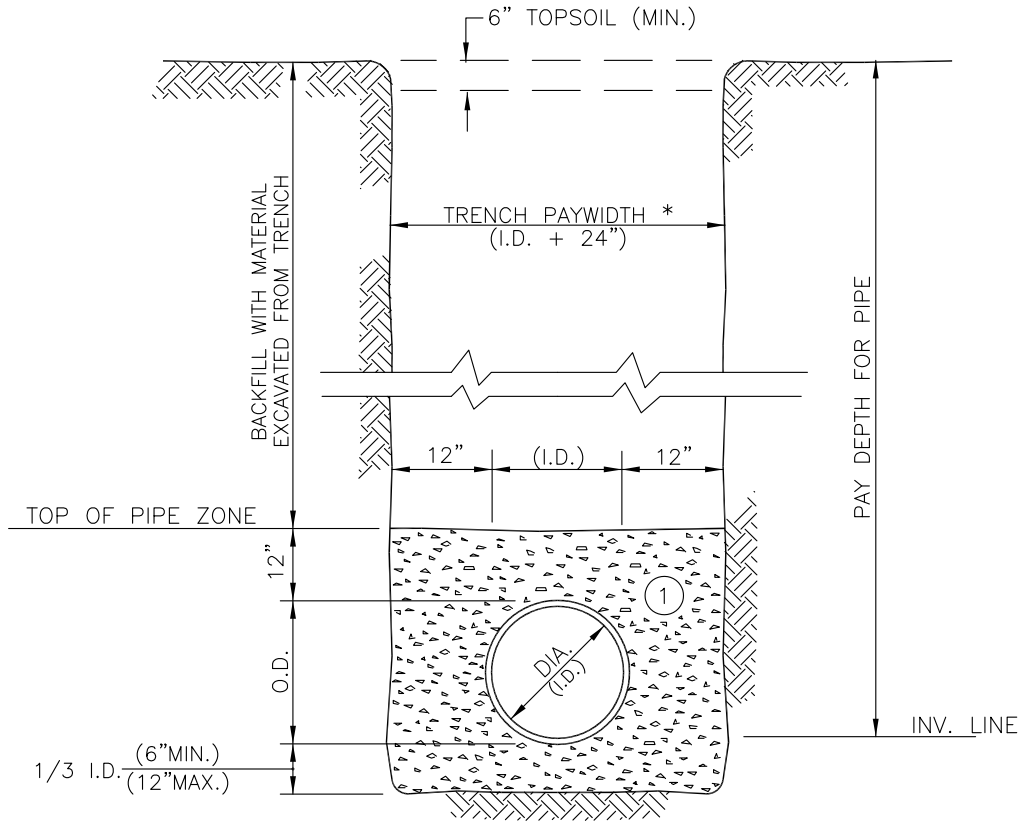

\* PAY WIDTHS OF UP TO 48" WIDE TOTAL MAY BE AUTHORIZED BY THE ENGINEER FOR SPOT REPAIRS TO ACCOUNT FOR CONTRACTORS LOCATION OF REPAIR AREA/DEFECTS.

- NOTES:
- A. PIPE INSTALLATION SHALL BE IN ACCORDANCE WITH MANUFACTURERS RECOMMENDATIONS.
  - B. TRENCHING OPERATIONS SHALL INCLUDE ALL NECESSARY DEWATERING.
  - C. TRENCH DETAILS ARE ONLY SHOWN FOR PURPOSES OF MATERIAL PLACEMENT AND MAXIMUM PAY LIMITS.
  - D. AN OSHA APPROVED MOVABLE PROTECTIVE TRENCH SHIELD SHALL BE USED IN ALL UNSHEETED TRENCH AREAS.

### MATERIALS

#### PIPE BEDDING MATERIAL (NYS DOT LATEST EDITION)

- ① NO.1 CRUSHED STONE WITH A GRADATION CONFORMING WITH NYS DOT SECTION 703-02. THE CRUSHED STONE SHALL BE WELL GRADED WITH NO PARTICLES LARGER THAN 1" AND HAVING A MAXIMUM GRADATION MEETING THE LIMITS DESCRIBED IN THE SPECIFICATIONS. THE BEDDING SHALL BE COMPACTED IN 6" LIFTS WITH EQUIPMENT ACCEPTABLE TO THE PIPE MANUFACTURER.

File: V:\DSM\Engineering\CAD\Details\Details November 2023\D-01SR.dwg, Last saved: 12/11/2023, Plot Date: 12/11/2023, Plot Style: DETAILS.CTB

**ERIE COUNTY**  
**DEPT. OF ENVIRONMENT & PLANNING**  
**DIVISION OF SEWERAGE MANAGEMENT**

Rev. 1	5/93	NOTE 2: PIPE INSTALLATION
Rev. 2	2/94	ADDED NOTE C & D
Rev. 3	11/23	ADDED * FOR SPOT REPAIRS WIDTHS

File: D-01SR

Date: Nov-2023

STD.DETAIL

1SR

# SHEETED TRENCH (NOVEMBER 2023)

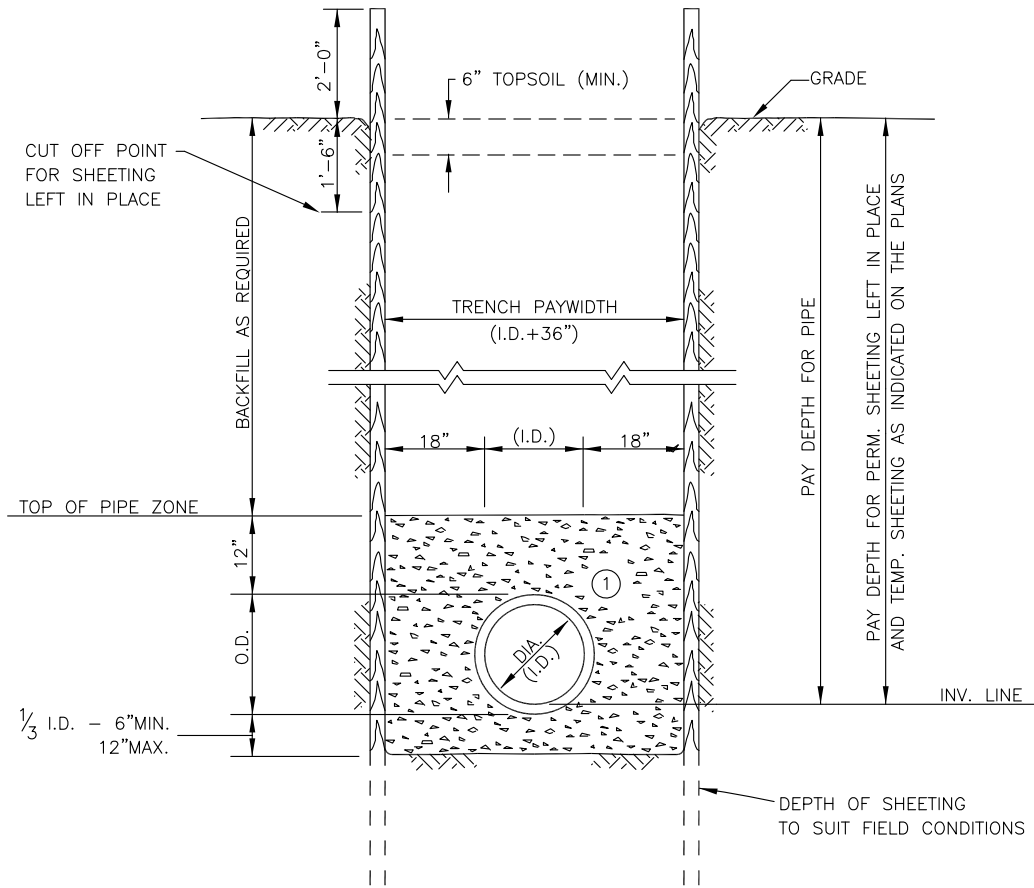

**NOTES:**

1. MAINTAIN 18" BETWEEN PIPE AND INSIDE FACE OF TEMPORARY SHEETING. IF SHEETING EXTENDS BELOW PIPE INVERT AS SHOWN, WHEN PVC PIPE MATERIAL IS USED, COMPACT MATERIAL ① BEFORE PULLING THE SHEETING.
2. SHEETED TRENCH OPERATIONS SHALL INCLUDE ALL NECESSARY DEWATERING EQUIPMENT.
3. SHEETING DRIVEN BELOW THE INVERT OF THE PIPE FOR BEDDING MATERIAL AND TOE SUPPORT WILL NOT BE CONSIDERED IN THE FORMULA FOR PAYMENT BUT SHOULD BE FIGURED BY THE CONTRACTOR IN DETERMINING HIS UNIT BID PRICE PER SQUARE FOOT OF SHEETING.
4. WHERE INDICATED ON THE PLANS OR AS ORDERED BY THE ENGINEER, TEMPORARY SHEETING WILL BE PAID FOR UNDER THE APPLICABLE BID ITEM. OTHER AREAS WHERE THE CONTRACTOR ELECTS TO USE TEMPORARY SHEETING NOT PREVIOUSLY AUTHORIZED BY THE ENGINEER SHALL BE AT HIS OPTION AND EXPENSE.

### MATERIALS

#### PIPE BEDDING MATERIAL (NYS DOT LATEST EDITION)

- ① NO.1 CRUSHED STONE WITH A GRADATION CONFORMING WITH NYS DOT SECTION 703-02. THE CRUSHED STONE SHALL BE WELL GRADED WITH NO PARTICLES LARGER THAN 1" AND HAVING A MAXIMUM GRADATION MEETING THE LIMITS DESCRIBED IN THE SPECIFICATIONS. THE BEDDING SHALL BE COMPACTED IN 6" LIFTS WITH EQUIPMENT ACCEPTABLE TO THE PIPE MANUFACTURER.

**ERIE COUNTY  
DEPT. OF ENVIRONMENT & PLANNING  
DIVISION OF SEWERAGE MANAGEMENT**

Rev. 1	REVISED TOPSOIL DIMENSION
2/7/94	

Rev. 2	UPDATED MATERIALS TO NYS DOT LATEST EDITION
6/5/06	

**File: D-02**

**Date: 3/1/91**

**STD.DETAIL**



# ROCK TRENCH DETAIL

## (NOVEMBER 2023)

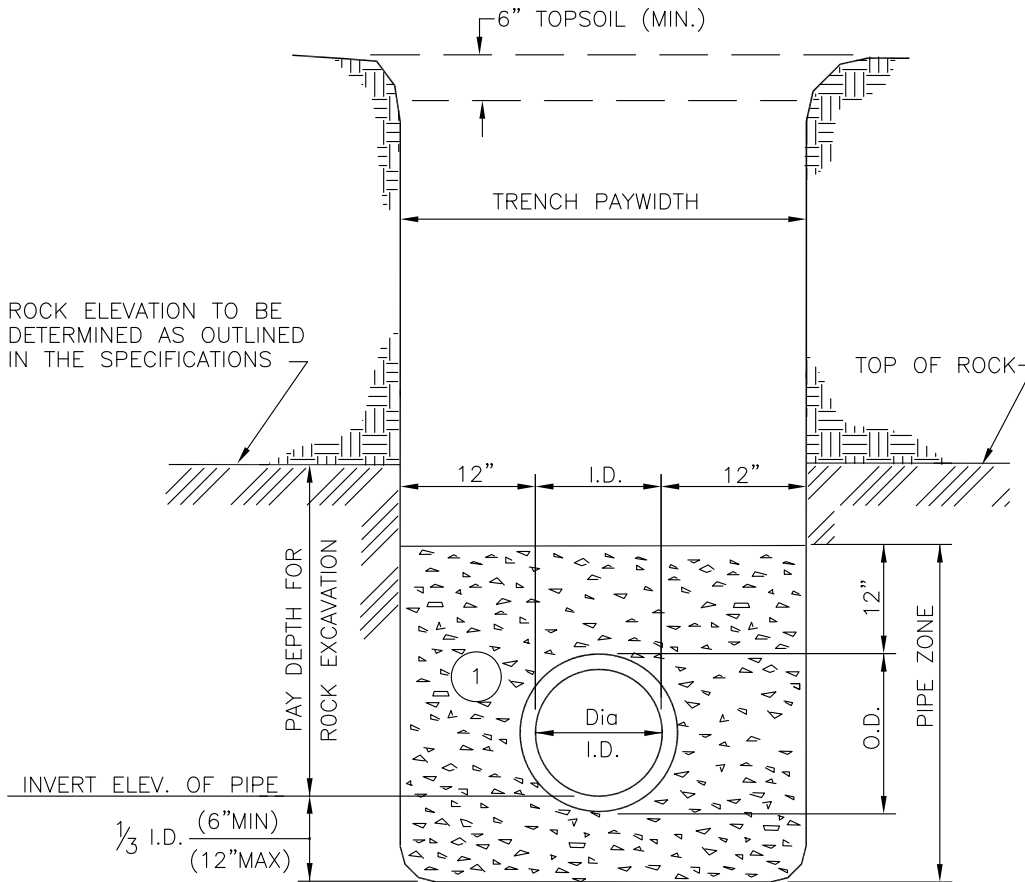

**NOTE:**

- A. TRENCH DETAILS ARE ONLY SHOWN FOR PURPOSES OF MATERIAL PLACEMENT AND MAXIMUM PAY LIMITS.
- B. AN OSHA APPROVED MOVABLE PROTECTIVE TRENCH SHIELD SHALL BE USED IN ALL UNSHEETED TRENCH AREAS.

### MATERIALS

#### PIPE BEDDING MATERIAL (NYS DOT LATEST EDITION)

- ① NO.1 CRUSHED STONE WITH A GRADATION CONFORMING WITH NYS DOT SECTION 703-02. THE CRUSHED STONE SHALL BE WELL GRADED WITH NO PARTICLES LARGER THAN 1" AND HAVING A MAXIMUM GRADATION MEETING THE LIMITS DESCRIBED IN THE SPECIFICATIONS. THE BEDDING SHALL BE COMPACTED IN 6" LIFTS WITH EQUIPMENT ACCEPTABLE TO THE PIPE MANUFACTURER.

<b>Rev. 1</b>	ADDED 6" TOPSOIL (MIN.)
1/6/94	
<b>Rev. 2</b>	ADDED NOTES A & B
2/7/94	
<b>File:</b>	<b>D-03</b>
<b>Date:</b>	<b>3/1/91</b>

# SELECT BACKFILL FOR TRENCH PARALLEL TO ROADWAYS (NOVEMBER 2023)

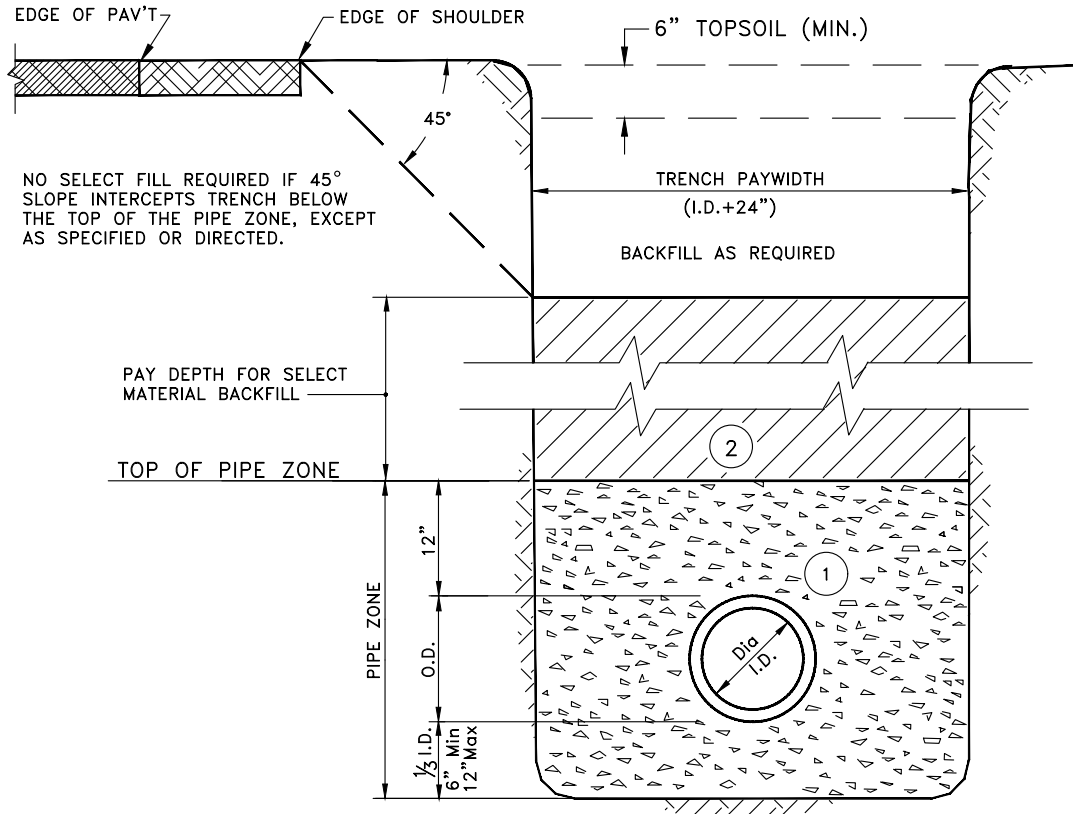

**NOTE:**

- A. TRENCH DETAILS ARE ONLY SHOWN FOR PURPOSES OF MATERIAL PLACEMENT AND MAXIMUM PAY LIMITS.
- B. AN OSHA APPROVED MOVABLE PROTECTIVE TRENCH SHIELD SHALL BE USED IN ALL UNSHEETED TRENCH AREAS.

### MATERIALS

#### PIPE BEDDING MATERIAL (NYS DOT LATEST EDITION)

- ① NO.1 CRUSHED STONE WITH A GRADATION CONFORMING WITH NYS DOT SECTION 703-02. THE CRUSHED STONE SHALL BE WELL GRADED WITH NO PARTICLES LARGER THAN ONE INCH AND HAVING A MAXIMUM GRADATION MEETING THE LIMITS DESCRIBED IN THE SPECIFICATIONS. THE BEDDING SHALL BE COMPACTED IN 6" LIFTS WITH EQUIPMENT ACCEPTABLE TO THE PIPE MANUFACTURER.

#### SELECT MATERIAL BACKFILL (NYS DOT LATEST EDITION)

- ② NO. 2 RUN OF CRUSHER STONE OR NO. 2 RUN OF CRUSHER GRAVEL WITH A GRADATION CONFORMING WITH NYS DOT STANDARD SPECIFICATION, 304.12 - TYPE 2 SUBBASE (COMPACTED IN 6" LIFTS TO 95% DENSITY)

NO SLAG SHALL BE ALLOWED FOR MATERIALS ① & ②

**ERIE COUNTY  
DEPT. OF ENVIRONMENT & PLANNING  
DIVISION OF SEWERAGE MANAGEMENT**

Rev. 2	12/00	UPDATED NYS DOT EDITIONS
Rev. 3	12/01	UPDATED NYS DOT EDITIONS
Rev. 4	11/23	UPDATED NYS DOT EDITIONS
File: D-04		Date: 3/1/91

STD.DETAIL

4

# WATERMAIN CROSSING DETAIL TYPICAL FOR ENCASEMENT (NOVEMBER 2023)

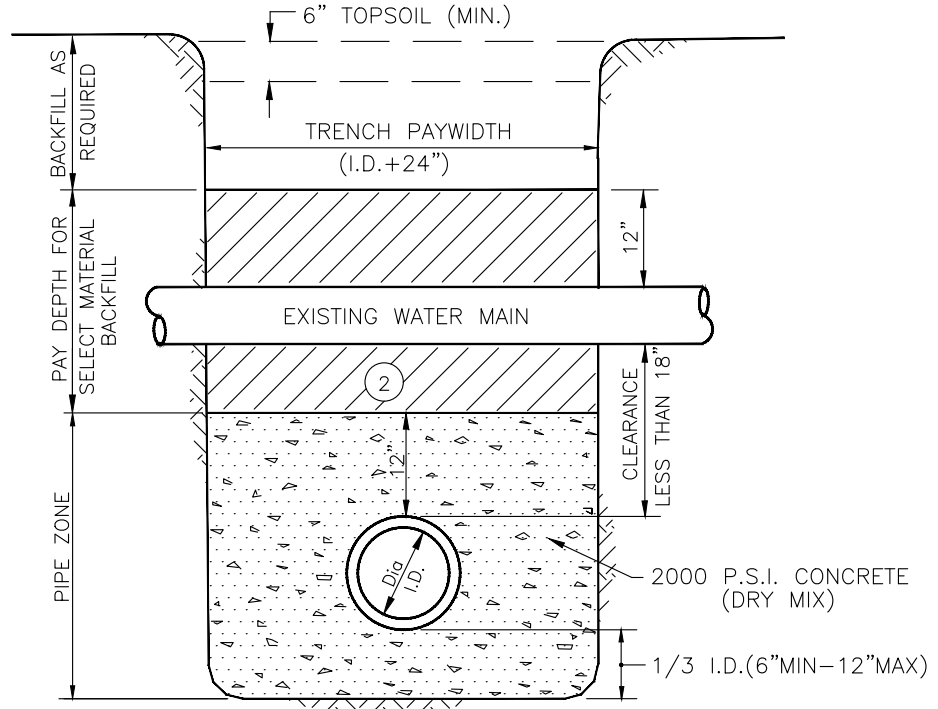

**NOTES:**

- A. IN ALL CASES WHERE THERE IS LESS THAN 18" CLEARANCE BETWEEN EXISTING WATER MAIN AND PROPOSED SEWER (INCLUDING HOUSE LATERALS) THE NEW WORK SHALL BE ENCASED IN CONCRETE AS SHOWN. WHEN A CASING PIPE IS SPECIFIED, NO CONCRETE ENCASEMENT IS REQUIRED.
- B. THE CONCRETE ENCASEMENT SHALL EXTEND 3'-0" EACH SIDE OF THE WATER MAIN.
- C. SEWERS SHALL BE LAID AT LEAST 10' (3.0 m) HORIZONTALLY FROM ANY EXISTING OR PROPOSED WATERMAIN THE DISTANCE SHALL BE MEASURED EDGE TO EDGE. IN CASES WHERE IT IS NOT PRACTICAL TO MAINTAIN A 10' SEPARATION, THE APPROPRIATE REVIEWING AGENCY MAY ALLOW DEVIATION ON A CASE BY CASE BASIS, IF SUPPORTED BY DATA FROM THE DESIGN ENGINEER. SUCH DEVIATION MAY ALLOW INSTALLATION OF THE SEWER CLOSER TO A WATERMAIN, PROVIDED THE WATERMAIN IS IN A SEPARATE TRENCH OR ON AN UNDISTURBED EARTH SHELF LOCATED ON ONE SIDE OF THE SEWER AND THE ELEVATION OF THE BOTTOM OF THE WATERMAIN IS AT LEAST 18" (46 cm) ABOVE THE TOP OF SEWER.
- D. SEWERS CROSSING WATERMAINS SHALL BE LAID TO PROVIDE MINIMUM VERTICAL DISTANCE OF 18" (46 CM) BETWEEN THE OUTSIDE OF THE WATERMAIN AND THE OUTSIDE OF THE SEWER. THIS SHALL BE THE CASE WHEN THE WATERMAIN IS ABOVE OR BELOW THE SEWER. THE CROSSING SHALL BE ARRANGED SO THE JOINTS OF THE SEWER PIPE WILL BE EQUIDISTANT FROM AND AS FAR AWAY FROM THE WATERMAIN JOINTS AS POSSIBLE. WHERE THE WATERMAIN CROSSES UNDER A SEWER, ADEQUATE STRUCTURAL SUPPORT SHALL BE PROVIDED FOR THE SEWER TO PREVENT DAMAGE TO THE WATERMAIN.
- E. WHEN IT IS IMPOSSIBLE TO OBTAIN THE PROPER HORIZONTAL AND VERTICAL SEPARATION AS STIPULATED ABOVE, THE SEWER SHALL BE EITHER ENCASED IN CONCRETE OR CONSTRUCTED OF PIPE MATERIAL EQUAL TO THE WATERMAIN AND PRESSURE TESTED AT 150 PSI TO ASSURE WATER TIGHTNESS.
- F. TRENCH DETAILS ARE ONLY SHOWN FOR PURPOSES OF MATERIALS PLACEMENT AND MAXIMUM PAY LIMITS.
- G. AN OSHA APPROVED MOVABLE PROTECTIVE TRENCH SHIELD SHALL BE USED IN ALL UNSHEETED TRENCH AREAS.

**MATERIALS**

SELECT MATERIAL BACKFILL (NYS DOT LATEST EDITION)

- ② NO.2 RUN OF CRUSHER STONE OR NO.2 RUN OF CRUSHER GRAVEL WITH A GRADATION CONFORMING WITH NYS DOT STANDARD SPECIFICATIONS, 304.12 - TYPE 2 SUBBASE. (COMPACTED IN 6" LIFTS TO 95% DENSITY)

NOTE: SLAG SHALL NOT BE ALLOWED FOR MATERIALS ②

File: V:\DSM\Engineering\CAD\Details\November 2023\D-05.dwg, Last saved: 12/11/2023, Plot Date: 5/21/2024, Plot Style: DETAILS.CTB

**ERIE COUNTY  
DEPT. OF ENVIRONMENT & PLANNING  
DIVISION OF SEWERAGE MANAGEMENT**

REV1	2/94	ADDED 6" TOPSOIL(MIN.) & NOTE F&G
REV2	01/01	REVISED NOTE A
REV3	12/01	Revised Note "A"
REV4	11/23	UPDATED NYS DOT BACKFILL ITEM
File:	D-05	Date: 3/1/91

**STD.DETAIL**

5

# TYPICAL CONCRETE ENCASEMENT DETAIL

## (NOVEMBER 2023)

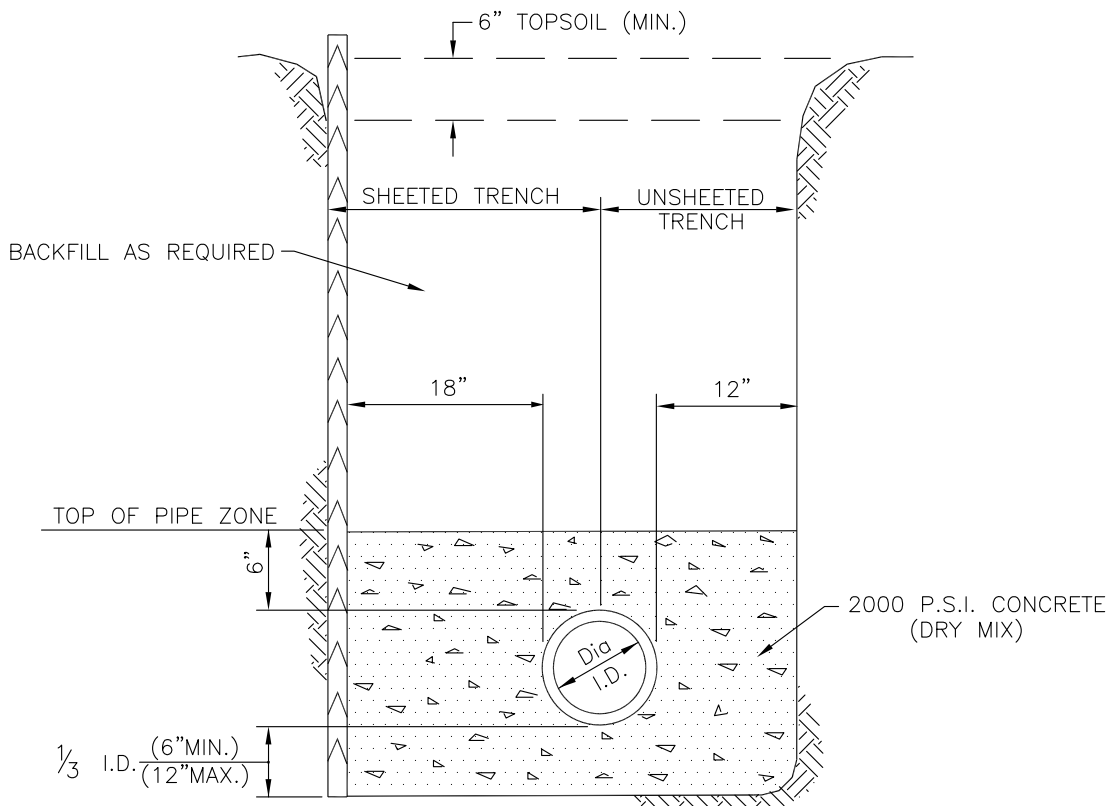

TYPICAL CONCRETE ENCASEMENT NOTES:

1. USE AS REQUIRED BY TEN STATE STANDARDS, OR AS ORDERED BY ENGINEER.
2. REQUIRED WHEN SEWER HAS LESS THAN 4 FEET OF COVER IN PAVED AREAS.

**Revisions**

8/23/91	ADDED 6" DIMENSION ABOVE SEWER
6/4/93	DELETED DEPTH REFERENCE NOTE
2/7/94	ADDED 6" TOPSOIL(MIN.) & NOTE
6/9/05	ADDED NOTES 1&2

**STD.DETAIL**

**ERIE COUNTY**  
**DEPT. OF ENVIRONMENT & PLANNING**  
**DIVISION OF SEWERAGE MANAGEMENT**

6

**File: D-06      Date: 3/1/91**

# CONCRETE CRADLE DETAIL

(NOVEMBER 2023)

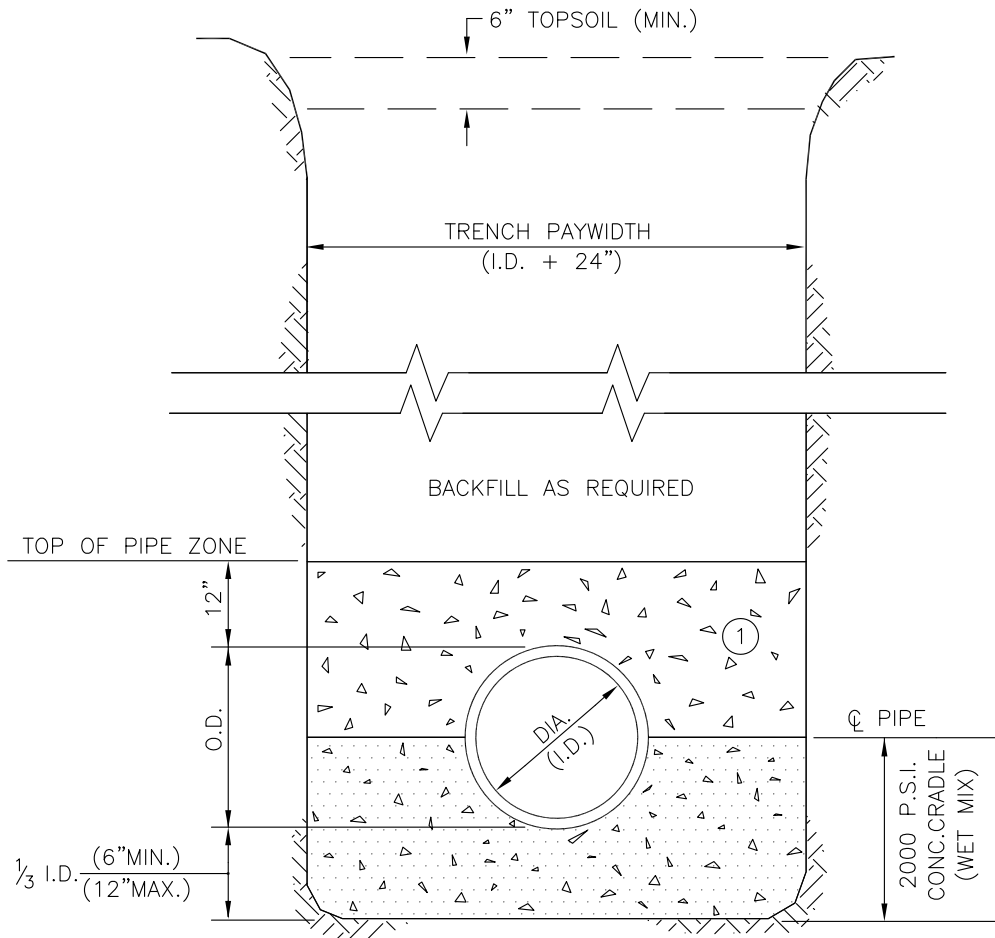

**NOTE:**

- A. TRENCH DETAILS ARE ONLY SHOWN FOR PURPOSES OF MATERIAL PLACEMENT AND MAXIMUM PAY LIMITS.
- B. AN OSHA APPROVED MOVABLE PROTECTIVE TRENCH SHIELD SHALL BE USED IN ALL UNSHEETED TRENCH AREAS.

### MATERIALS

#### PIPE BEDDING MATERIAL (NYS DOT LATEST EDITION)

- ① NO.1 CRUSHED STONE WITH A GRADATION CONFORMING WITH NYS DOT SECTION 703-02. THE CRUSHED STONE SHALL BE WELL GRADED WITH NO PARTICLES LARGER THAN 1" AND HAVING A MAXIMUM GRADATION MEETING THE LIMITS DESCRIBED IN THE SPECIFICATIONS. THE BEDDING SHALL BE COMPACTED IN 6" LIFTS WITH EQUIPMENT ACCEPTABLE TO THE PIPE MANUFACTURER.

File: V:\DSM\Engineering\CAD\Details\November 2023\D-07.dwg, Last saved: 12/5/2023, Plot Date: 12/11/2023, Plot Style: DETAILS.CTB

**ERIE COUNTY**  
DEPT. OF ENVIRONMENT & PLANNING  
DIVISION OF SEWERAGE MANAGEMENT

Rev. 1	ADDED 6" TOPSOIL & NOTE A & B
2/7/94	
Rev. 2	
File: D-07	Date: 3/1/91

**STD.DETAIL**

7



# PAVEMENT AND DRIVEWAY REPLACEMENT DETAIL (NOVEMBER 2023)

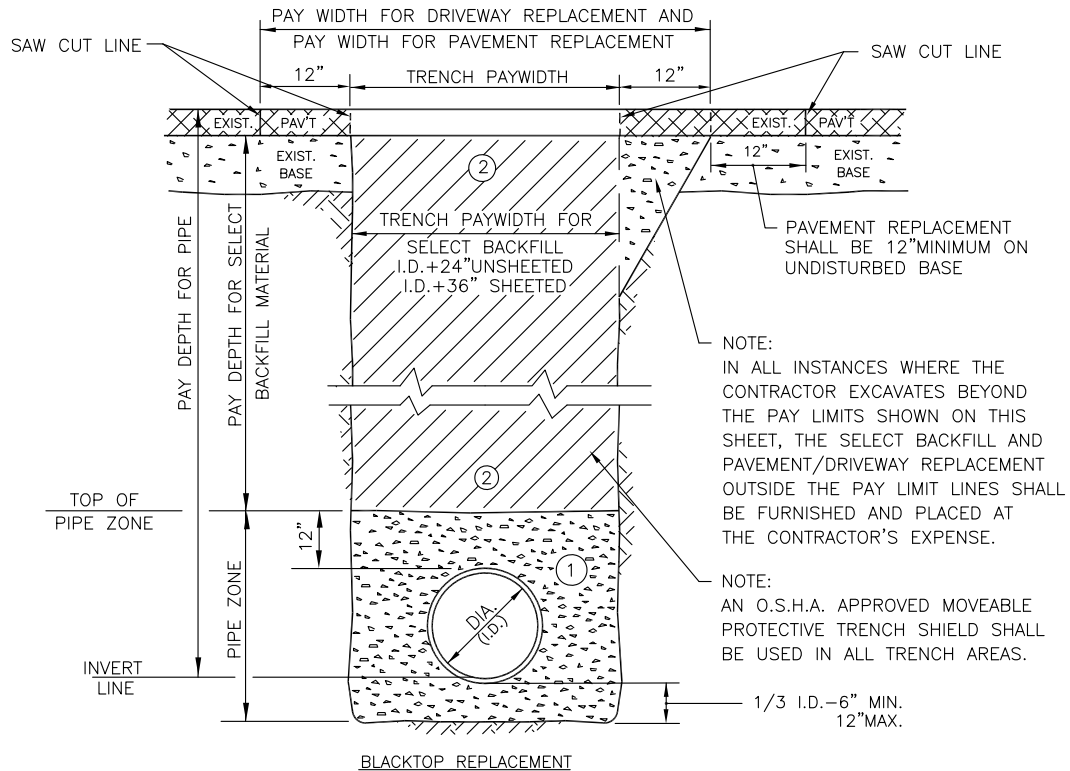

ALL ROADS SHALL BE RECONSTRUCTED WITH A MIN. 4" COURSE OF BASE, 2" COURSE OF BINDER AND 1-1/2" TOP COURSE. APPLICABLE HIGHWAY PERMIT CONDITIONS SHALL GOVERN. DRIVEWAYS SHALL MATCH EXISTING

- TEMP. PAV'T.**
1. IF CONSTRUCTION IS PERFORMED BETWEEN OCTOBER 1 AND APRIL 1, THE CONTRACTOR IS REQUIRED TO PROVIDE 4" OF COLD PATCH FOR ALL PAVEMENT CUTS.
  2. ALL OPEN CUTS WITHIN 50' OF AN INTERSECTION SHALL BE TOPPED WITH 4" OF COLD PATCH REGARDLESS OF THE TIME OF YEAR.
  3. ALL ROAD CUTS ON HEAVILY TRAVELED ROADWAYS WILL REQUIRE 4" OF COLD PATCH (GENERALLY STATE AND COUNTY HIGHWAYS)
  4. ALL TEMPORARY PAVEMENT PATCHES SHALL BE MAINTAINED BY THE CONTRACTOR.

- SAW CUTS**
1. PAVEMENT/DRIVEWAY CUTS BY THE CONTRACTOR WILL BE MADE WITH A SAW, PNEUMATIC SPADE OR OTHER ACCEPTED MEANS PRIOR TO EXCAVATION.
  2. FINAL PAVEMENT/DRIVEWAY RESTORATION: THE CONTRACTOR WILL BE RESPONSIBLE TO SAW CUT AN ADDITIONAL 12" ON EACH SIDE OF THE DISTURBED TRENCH AREA, SO AS TO PROVIDE A UNIFORM STRAIGHT EDGE. THE CUT EDGE WILL THEN BE COATED WITH A BITUMINOUS SEAL COAT AND REPLACED IN THE MANNER DESCRIBED ABOVE.

**CONCRETE DRIVEWAY REPLACEMENT**

1. THE CONTRACTOR SHALL REMOVE ALL CONCRETE DAMAGE BY HIS OPERATION. THE EXISTING CONCRETE AT THE DAMAGED EDGE SHALL BE SAW CUT TO PROVIDE A STRAIGHT EDGE JOINT BETWEEN OLD AND NEW, WITH EXPANSION JOINT MATERIAL INSTALLED AT THE TRANSITION. THE CONTRACTOR SHALL BE REQUIRED TO RECONSTRUCT THE DRIVEWAY WITH 4000 PSI CONCRETE MATCHING THE DEPTH AND WIDTH OF THE EXISTING DRIVEWAY.

**MATERIALS**

**PIPE BEDDING MATERIAL (NYS DOT LATEST EDITION)**

- ① NO.1 CRUSHED STONE WITH A GRADATION CONFORMING WITH NYSDOT SECTION 703-02. THE CRUSHED STONE SHALL BE WELL GRADED WITH NO PARTICLES LARGER THAN 1" AND HAVING A MAXIMUM GRADATION MEETING THE LIMITS DESCRIBED IN THE SPECIFICATIONS. THE BEDDING SHALL BE COMPACTED IN 6" LIFTS WITH EQUIPMENT ACCEPTABLE TO THE PIPE MANUFACTURER.

**SELECT MATERIAL BACKFILL (NYS DOT LATEST EDITION)**

- ② NO.2 RUN OF CRUSHER STONE OR NO.2 RUN OF CRUSHER GRAVEL WITH A GRADATION CONFORMING WITH NYSDOT STANDARD SPECIFICATIONS, ITEM 304.12-TYPE 2 SUBBASE (COMPACTED IN 6" LIFTS TO 95% DENSITY)

**NOTE:** SLAG SHALL NOT BE ALLOWED FOR MATERIALS ① AND ②

**ERIE COUNTY  
DEPT. OF ENVIRONMENT & PLANNING  
DIVISION OF SEWERAGE MANAGEMENT**

Rev. 2		REVISED PAY LIMITS FOR TRENCH
Rev. 3	01/01	REVISED TITLE AND PAY WIDTH
Rev. 4	12/01	Added conc. driveway replace note
Rev. 5	11/23	REVISED ROADWAY COURSE DEPTHS
		& NYSDOT SPECIFICATIONS

File: D-08 Date: 3/1/91

STD.DETAIL



# PIPE CROSSING SUPPORT DETAIL

(NOVEMBER 2023)

EXIST. PIPE CROSSING (SEE WATER MAIN CROSSING DETAIL FOR CONCRETE ENCASEMENT.)

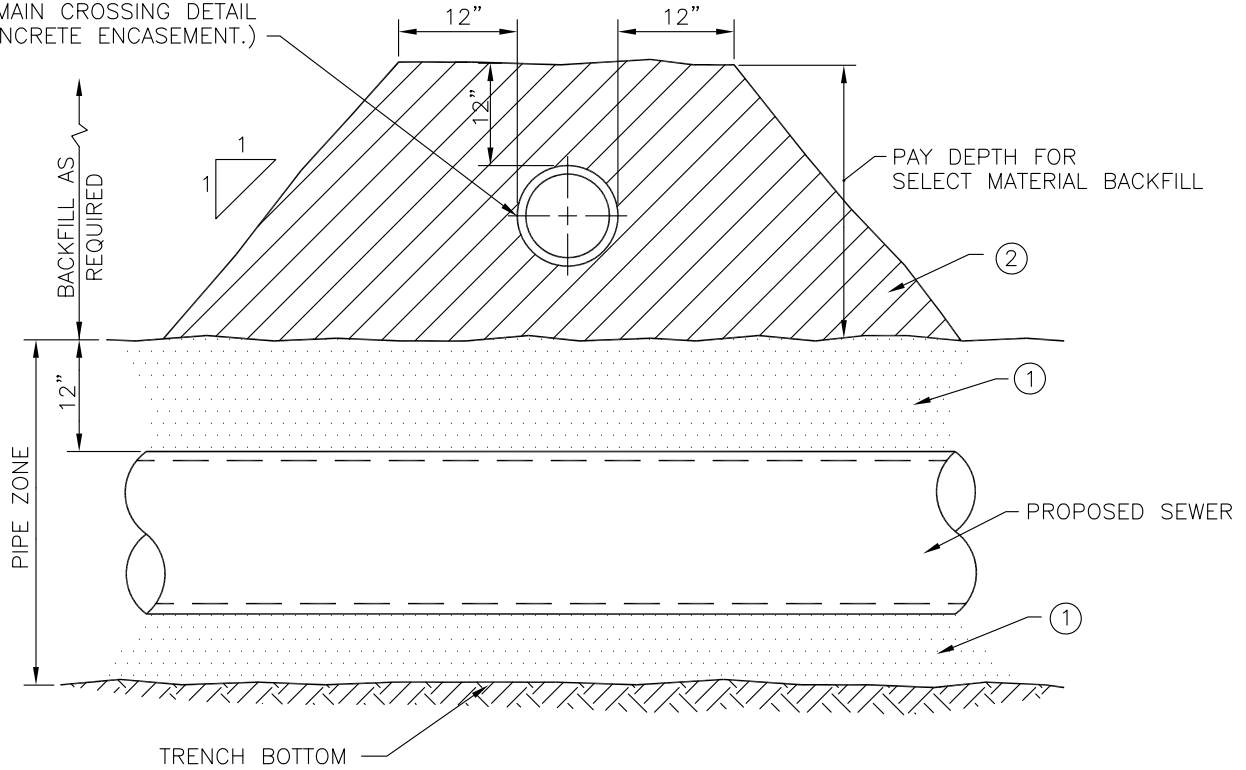

## MATERIALS

### PIPE BEDDING MATERIAL (NYS DOT LATEST EDITION)

- ① NO.1 CRUSHED STONE WITH A GRADATION CONFORMING WITH NYSDOT SECTION 703-02. THE CRUSHED STONE SHALL BE WELL GRADED WITH NO PARTICLES LARGER THAN 1" AND HAVING A MAXIMUM GRADATION MEETING THE LIMITS DESCRIBED IN THE SPECIFICATIONS. THE BEDDING SHALL BE COMPACTED IN 6" LIFTS WITH EQUIPMENT ACCEPTABLE TO THE PIPE MANUFACTURER.

### SELECT MATERIAL BACKFILL (NYS DOT LATEST EDITION)

- ② NO.2 RUN OF CRUSHER STONE OR NO.2 RUN OF CRUSHER GRAVEL WITH A GRADATION CONFORMING WITH NYSDOT STANDARD SPECIFICATION 304.12 - TYPE 2 SUBBASE (COMPACTED IN 6" LIFTS TO 95% DENSITY)

NOTE: SLAG SHALL NOT BE ALLOWED FOR MATERIALS ① AND ②

<b>Rev. 1</b>	UPDATED MATERIALS TO NYSDOT LATEST EDITION
12/01	
<b>Rev. 2</b>	UPDATED MATERIALS TO NYSDOT LATEST EDITION
11/23	
<b>File:</b>	<b>D-09</b>
<b>Date:</b>	<b>3/1/91</b>

**MONOLITHIC PRECAST BASE MANHOLES**  
**4'-0" DIA. BASE FOR 15"Ø SEWERS OR LESS**  
 (NOVEMBER 2023)

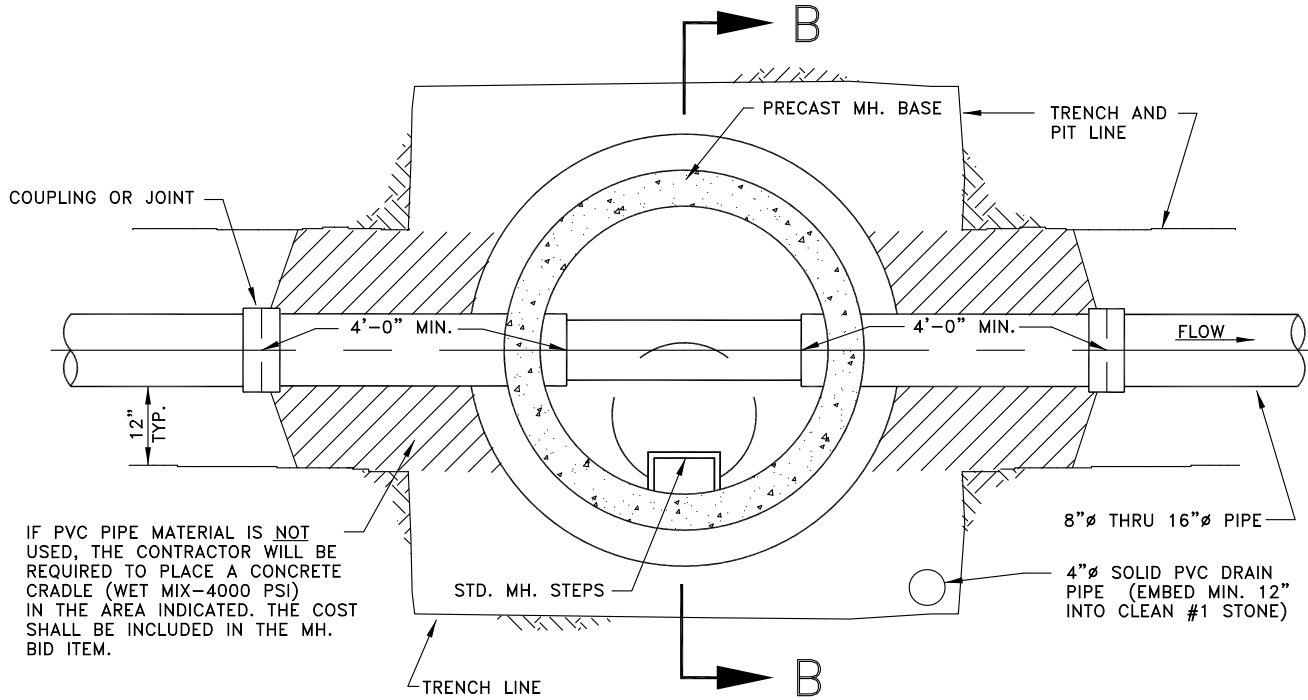

PLAN

File: V:\DSMA\Engineering\CAD\Details\November 2023\D-10.dwg, Last saved: 12/5/2023, Plot Date: 12/11/2023, Plot Style: DETAILS.CTB

**ERIE COUNTY**  
**DEPT. OF ENVIRONMENT & PLANNING**  
**DIVISION OF SEWERAGE MANAGEMENT**

Rev. 1	REVISED 4" PVC TO SOLID PIPE
12/01	IN #1 STONE BED
Rev. 2	
File:	D-10
Date:	3/1/91

STD.DETAIL

10

# MONOLITHIC PRECAST BASE MANHOLES 4'-0" DIA. BASE FOR 15" Ø SEWERS OR LESS (SECTION B-B) (NOVEMBER 2023)

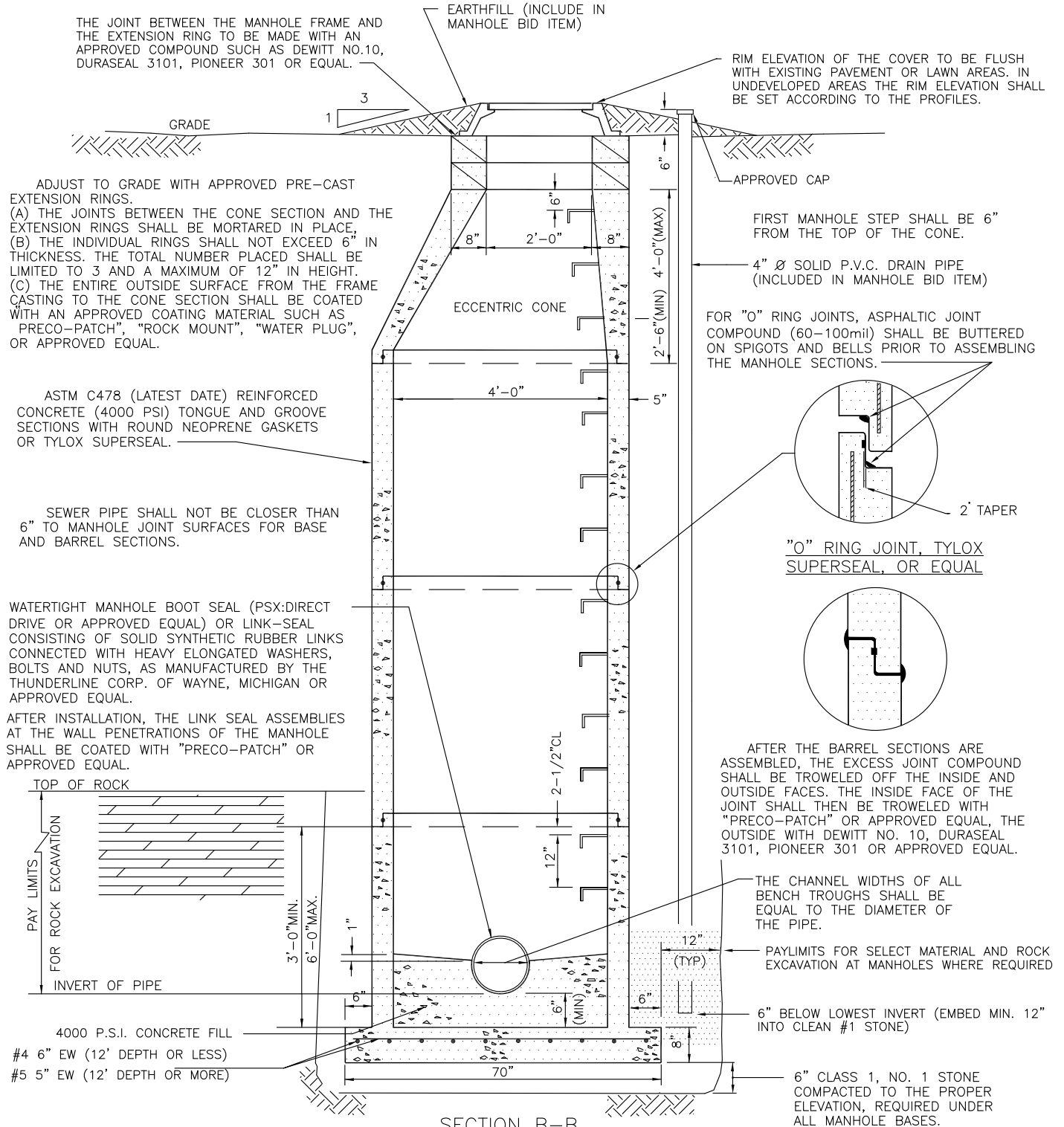

### Revisions

07/15/99	ADD ROCK EXCAVATION PAYLIMITS
11/23/99	ADD 4"x4"x6" MARKER AND NOTES
12/01	REVISED 4" P.V.C. TO SOLID PIPE
03/04/03	ADDED WATER TIGHT BOOT SEAL NOTE
06/22/05	ADDED TYLOX SUPERSEAL NOTES REMOVED WOOD POST AND NOTES
02/27/07	CHANGED THE NUMBER OF EXTENSION RINGS FROM 2 TO 3
File:	D-11
Date:	3/1/91

**STD.DETAIL**

1 1

**ERIE COUNTY  
DEPT. OF ENVIRONMENT & PLANNING  
DIVISION OF SEWERAGE MANAGEMENT**

# MONOLITHIC PRECAST BASE MANHOLES 4'-0" DIA. BASE FOR 15"Ø SEWERS OR LESS, SUBDIVISIONS & PRIVATE EXTENSIONS (SECTION B-B)

(NOVEMBER 2023)

THE JOINT BETWEEN THE MANHOLE FRAME AND THE EXTENSION RING TO BE MADE WITH AN APPROVED COMPOUND SUCH AS DEWITT NO.10, DURASEAL 3101, PIONEER 301 OR EQUAL.

EARTHFILL (INCLUDE IN MANHOLE BID ITEM)

4"x4"x 6' WOOD POST (SUBDIVISIONS AND PRIVATE EXTENSIONS ONLY) POST TO PROTECT MANHOLE FRAMES AND COVERS FROM MOVEMENT DURING LANDSCAPING. POST TO BE REMOVED AFTER LANDSCAPING IS COMPLETE.

RIM ELEVATION OF THE COVER TO BE FLUSH WITH EXISTING PAVEMENT OR LAWN AREAS. IN UNDEVELOPED AREAS THE RIM ELEVATION SHALL BE SET ACCORDING TO THE PROFILES.



ADJUST TO GRADE WITH APPROVED PRE-CAST EXTENSION RINGS.

(A) THE JOINTS BETWEEN THE CONE SECTION AND THE EXTENSION RINGS SHALL BE MORTARED IN PLACE,  
(B) THE INDIVIDUAL RINGS SHALL NOT EXCEED 6" IN THICKNESS. THE TOTAL NUMBER PLACED SHALL BE LIMITED TO 3 AND A MAXIMUM OF 12" IN HEIGHT.  
(C) THE ENTIRE OUTSIDE SURFACE FROM THE FRAME CASTING TO THE CONE SECTION SHALL BE COATED WITH AN APPROVED COATING MATERIAL SUCH AS "PRECO-PATCH", "ROCK MOUNT", "WATER PLUG", OR APPROVED EQUAL.

FIRST MANHOLE STEP SHALL BE 6" FROM THE TOP OF THE CONE.

4" Ø SOLID P.V.C. DRAIN PIPE (INCLUDED IN MANHOLE BID ITEM)

FOR "O" RING JOINTS, ASPHALTIC JOINT COMPOUND (60-100mil) SHALL BE BUTTERED ON SPIGOTS AND BELLS PRIOR TO ASSEMBLING THE MANHOLE SECTIONS.

ASTM C478 (LATEST DATE) REINFORCED CONCRETE (4000 PSI) TONGUE AND GROOVE SECTIONS WITH ROUND NEOPRENE GASKETS OR TYLOX SUPERSEAL.

SEWER PIPE SHALL NOT BE CLOSER THAN 6" TO MANHOLE JOINT SURFACES FOR BASE AND BARREL SECTIONS.

WATERTIGHT MANHOLE BOOT SEAL (PSX:DIRECT DRIVE OR APPROVED EQUAL) OR LINK-SEAL CONSISTING OF SOLID SYNTHETIC RUBBER LINKS CONNECTED WITH HEAVY ELONGATED WASHERS, BOLTS AND NUTS, AS MANUFACTURED BY THE THUNDERLINE CORP. OF WAYNE, MICHIGAN OR APPROVED EQUAL.

AFTER INSTALLATION, THE LINK SEAL ASSEMBLIES AT THE WALL PENETRATIONS OF THE MANHOLE SHALL BE COATED WITH "PRECO-PATCH" OR APPROVED EQUAL.

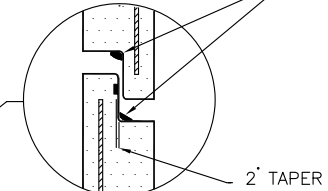

"O" RING JOINT, TYLOX SUPERSEAL, OR EQUAL

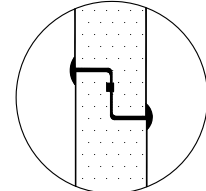

AFTER THE BARREL SECTIONS ARE ASSEMBLED, THE EXCESS JOINT COMPOUND SHALL BE TROWELED OFF THE INSIDE AND OUTSIDE FACES. THE INSIDE FACE OF THE JOINT SHALL THEN BE TROWELED WITH "PRECO-PATCH" OR APPROVED EQUAL, THE OUTSIDE WITH DEWITT NO. 10, DURASEAL 3101, PIONEER 301 OR APPROVED EQUAL.

THE CHANNEL WIDTHS OF ALL BENCH TROUGHS SHALL BE EQUAL TO THE DIAMETER OF THE PIPE.

PAYLIMITS FOR SELECT MATERIAL AND ROCK EXCAVATION AT MANHOLES WHERE REQUIRED

6" BELOW LOWEST INVERT (EMBED MIN. 12" INTO CLEAN #1 STONE)

6" CLASS 1, NO. 1 STONE COMPACTED TO THE PROPER ELEVATION, REQUIRED UNDER ALL MANHOLE BASES.

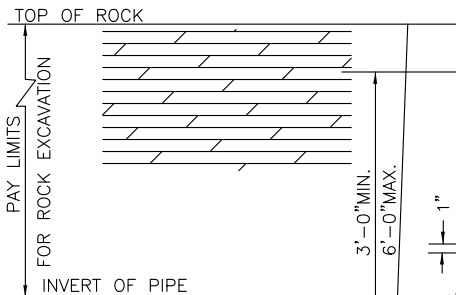

4000 P.S.I. CONCRETE FILL  
#4 6" EW (12' DEPTH OR LESS)  
#5 5" EW (12' DEPTH OR MORE)

SECTION B-B

File: V:\DSM\Engineering\CAD\Details\November 2023\D-11a.dwg, Last saved: 12/5/2023, Plot Date: 12/11/2023, Plot Style: DETAILS.CTB

**ERIE COUNTY**  
**DEPT. OF ENVIRONMENT & PLANNING**  
**DIVISION OF SEWERAGE MANAGEMENT**

Revisions	
02/27/07	CHANGED THE NUMBER OF EXTENSION RINGS FROM 2 TO 3
File: D-11a	Date: 6\22\05

STD.DETAIL

11a

# MONOLITHIC PRECAST BASE MANHOLES

## PIPE SIZES 18"Ø THRU 36"Ø

(NOVEMBER 2023)

THE JOINT BETWEEN THE MANHOLE FRAME AND THE EXTENSION RING TO BE MADE WITH AN APPROVED COMPOUND SUCH AS DEWITT NO.10, DURASEAL 3101, PIONEER 301 OR EQUAL.

RIM ELEVATION TO BE FLUSH WITH EXISTING PAVEMENT OR LAWN AREAS. IN UNDEVELOPED AREAS SET THE RIM ELEVATION ACCORDING TO THE PROFILES.

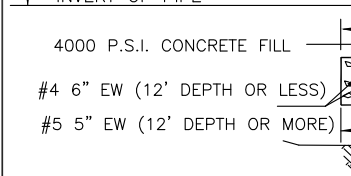
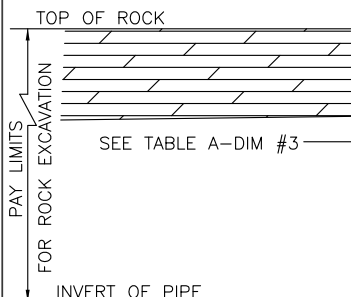
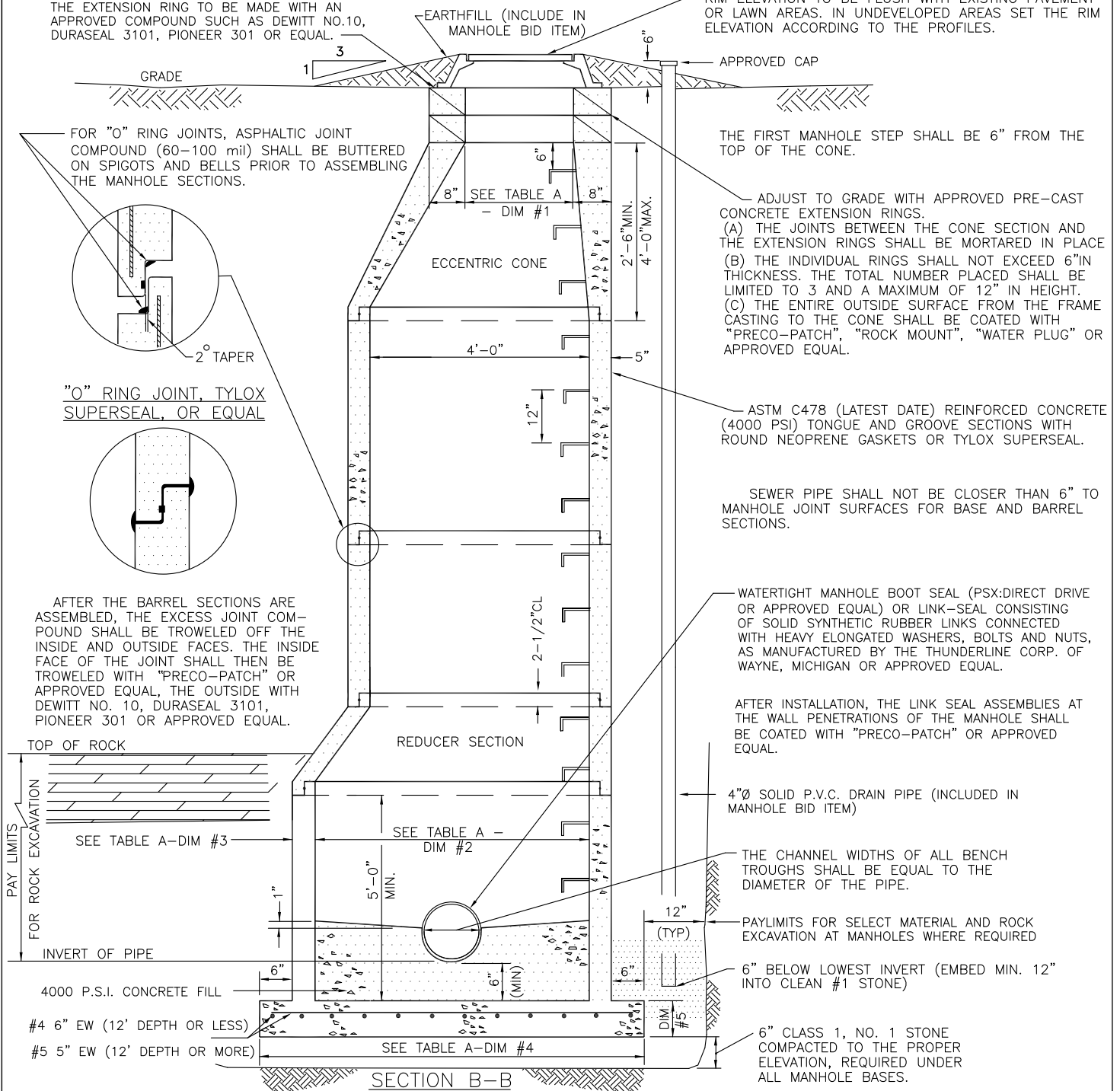

TABLE A					
PIPE SIZE	DIMENSION #1	DIMENSION #2	DIMENSION #3	DIMENSION #4	DIMENSION #5
18"	24"	5'-0"	6"	84"	8"
21"- 27"	36"	6'-0"	7"	98"	8"
30"- 36"	36"	8'-0"	9"	126"	14"

### REVISIONS

12/9/96	CHANGED JOINT COMPOUND TO ASPHALTIC (60-100 mil)
07/15/99	ADD ROCK ELEVATIONS
12/01	REVISED 4" P.V.C. TO SOLID PIPE
03/04/03	ADDED WATER TIGHT BOOT SEAL NOTE
06/22/05	ADDED TYLOX SUPERSEAL NOTES
02/27/07	CHANGED THE NUMBER OF EXTENSION RINGS FROM 2 TO 3

STD.DETAIL

12

File: D-12 Date: 3/1/91

# MONOLITHIC PRECAST BASE MANHOLES 18"Ø THRU 36"Ø, SUBDIVISIONS & PRIVATE EXTENSIONS (NOVEMBER 2023)

THE JOINT BETWEEN THE MANHOLE FRAME AND THE EXTENSION RING TO BE MADE WITH AN APPROVED COMPOUND SUCH AS DEWITT NO.10, DURASEAL 3101, PIONEER 301 OR EQUAL.

RIM ELEVATION TO BE FLUSH WITH EXISTING PAVEMENT OR LAWN AREAS. IN UNDEVELOPED AREAS SET THE RIM ELEVATION ACCORDING TO THE PROFILES.

THE FIRST MANHOLE STEP SHALL BE 6" FROM THE TOP OF THE CONE.

APPROVED CAP

4"x4"x 6' WOOD POST (SUBDIVISIONS AND PRIVATE EXTENSIONS ONLY) POST TO PROTECT MANHOLE FRAMES AND COVERS FROM MOVEMENT DURING LANDSCAPING. POST TO BE REMOVED AFTER LANDSCAPING IS COMPLETE.

ADJUST TO GRADE WITH APPROVED PRE-CAST CONCRETE EXTENSION RINGS.

(A) THE JOINTS BETWEEN THE CONE SECTION AND THE EXTENSION RINGS SHALL BE MORTARED IN PLACE  
(B) THE INDIVIDUAL RINGS SHALL NOT EXCEED 6" IN THICKNESS. THE TOTAL NUMBER PLACED SHALL BE LIMITED TO 3 AND A MAXIMUM OF 12" IN HEIGHT.  
(C) THE ENTIRE OUTSIDE SURFACE FROM THE FRAME CASTING TO THE CONE SHALL BE COATED WITH "PRECO-PATCH", "ROCK MOUNT", "WATER PLUG" OR APPROVED EQUAL.

ASTM C478 (LATEST DATE) REINFORCED CONCRETE (4000 PSI) TONGUE AND GROOVE SECTIONS WITH ROUND NEOPRENE GASKETS OR TYLOX SUPERSEAL.

SEWER PIPE SHALL NOT BE CLOSER THAN 6" TO MANHOLE JOINT SURFACES FOR BASE AND BARREL SECTIONS.

WATERTIGHT MANHOLE BOOT SEAL (PSX-DIRECT DRIVE OR APPROVED EQUAL) OR LINK-SEAL CONSISTING OF SOLID SYNTHETIC RUBBER LINKS CONNECTED WITH HEAVY ELONGATED WASHERS, BOLTS AND NUTS, AS MANUFACTURED BY THE THUNDERLINE CORP. OF WAYNE, MICHIGAN OR APPROVED EQUAL.

AFTER INSTALLATION, THE LINK SEAL ASSEMBLIES AT THE WALL PENETRATIONS OF THE MANHOLE SHALL BE COATED WITH "PRECO-PATCH" OR APPROVED EQUAL.

4"Ø SOLID P.V.C. DRAIN PIPE (INCLUDED IN MANHOLE BID ITEM)

THE CHANNEL WIDTHS OF ALL BENCH TROUGHS SHALL BE EQUAL TO THE DIAMETER OF THE PIPE.

PAYLIMITS FOR SELECT MATERIAL AND ROCK EXCAVATION AT MANHOLES WHERE REQUIRED

6" BELOW LOWEST INVERT (EMBED MIN. 12" INTO CLEAN #1 STONE)

6" CLASS 1, NO. 1 STONE COMPACTED TO THE PROPER ELEVATION, REQUIRED UNDER ALL MANHOLE BASES.

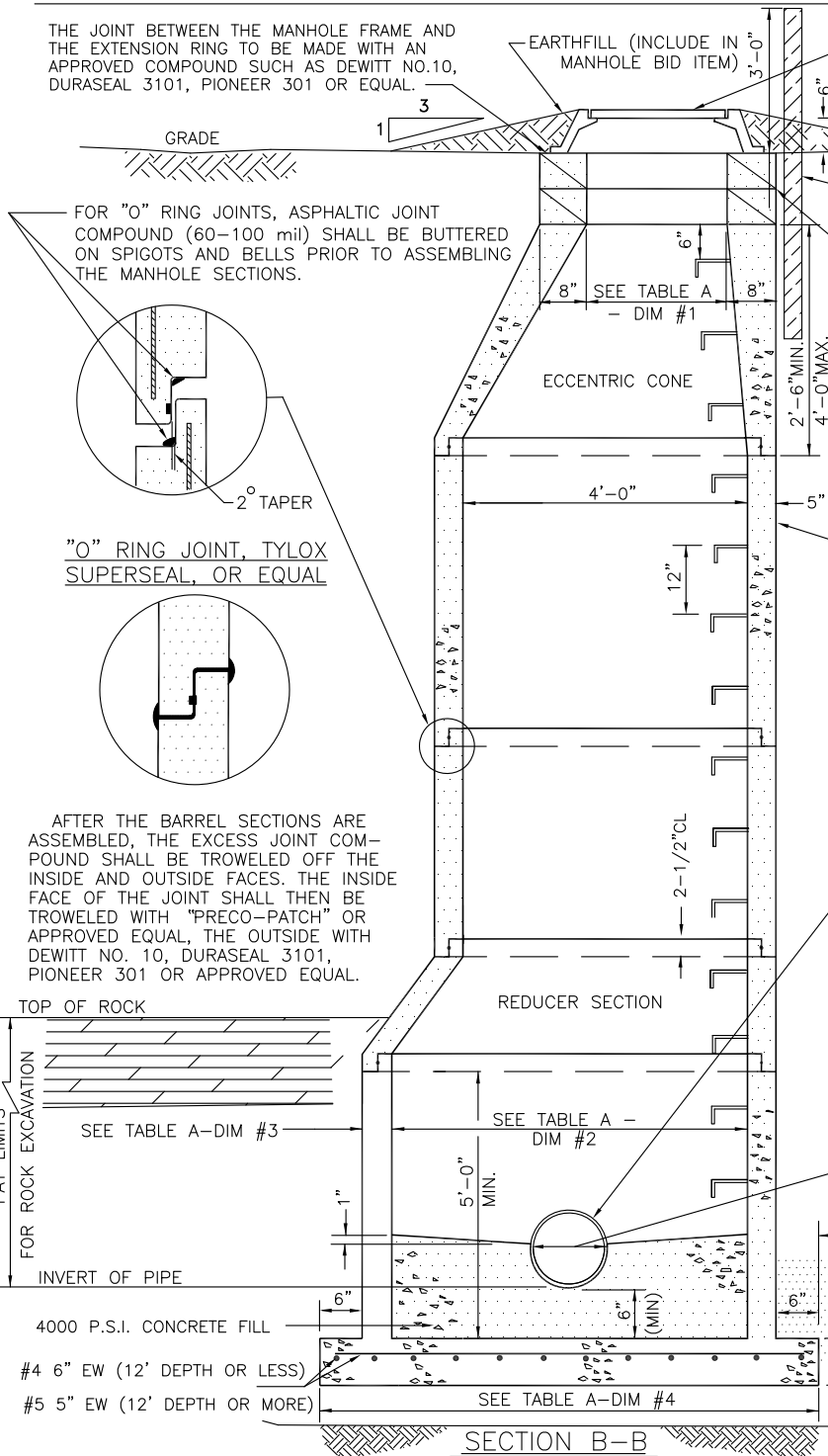

FOR "O" RING JOINTS, ASPHALTIC JOINT COMPOUND (60-100 mil) SHALL BE BUTTERED ON SPIGOTS AND BELLS PRIOR TO ASSEMBLING THE MANHOLE SECTIONS.

2° TAPER

"O" RING JOINT, TYLOX SUPERSEAL, OR EQUAL

AFTER THE BARREL SECTIONS ARE ASSEMBLED, THE EXCESS JOINT COMPOUND SHALL BE TROWELED OFF THE INSIDE AND OUTSIDE FACES. THE INSIDE FACE OF THE JOINT SHALL THEN BE TROWELED WITH "PRECO-PATCH" OR APPROVED EQUAL, THE OUTSIDE WITH DEWITT NO. 10, DURASEAL 3101, PIONEER 301 OR APPROVED EQUAL.

TABLE A

PIPE SIZE	DIMENSION #1	DIMENSION #2	DIMENSION #3	DIMENSION #4	DIMENSION #5
18"	24"	5'-0"	6"	84"	8"
21" - 27"	36"	6'-0"	7"	98"	8"
30" - 36"	36"	8'-0"	9"	126"	14"

ERIE COUNTY  
DEPT. OF ENVIRONMENT & PLANNING  
DIVISION OF SEWERAGE MANAGEMENT

REVISIONS

02/27/07 CHANGED THE NUMBER OF EXTENSION RINGS FROM 2 TO 3

STD.DETAIL

12a

File: D-12a

Date: 6/23/05

# STANDARD FRAME AND COVER

(NOVEMBER 2023)

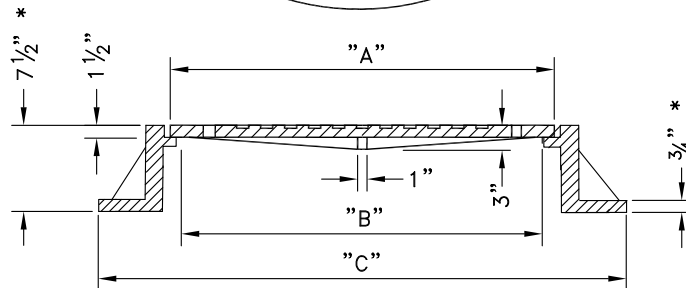
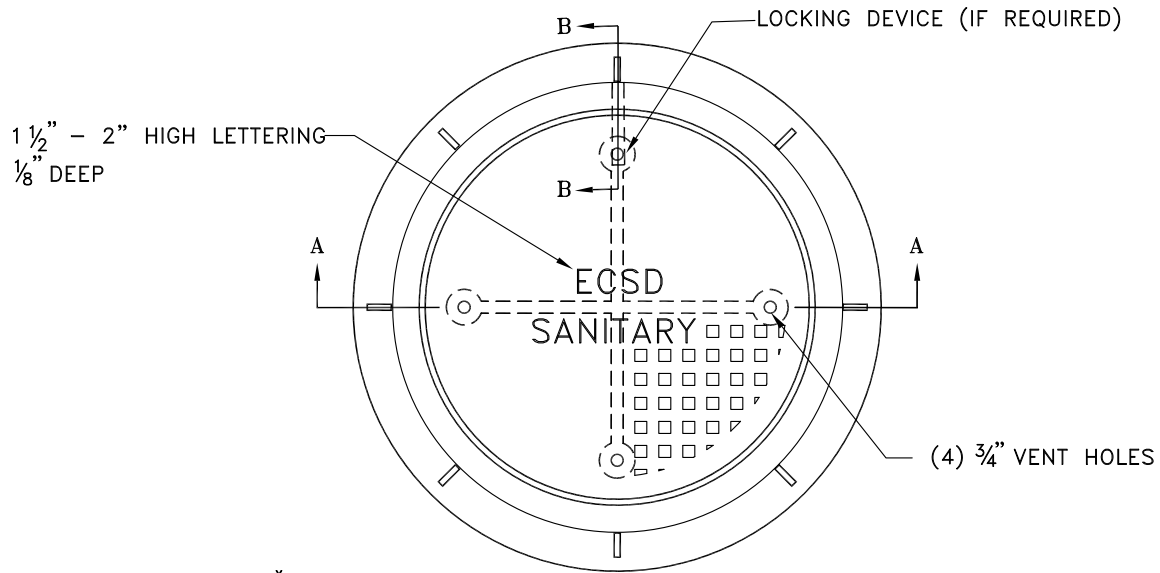

SECTION A-A

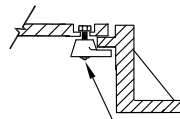

ROTATE CAM TO LOCK COVER (OR EQUAL)

B-B

LOCKING DEVICE IF REQUIRED

TABLE				
PIPE SIZE	DIMENSION "A"	DIMENSION "B"	DIMENSION "C"	WEIGHT OF COVER
8" THRU 18"	24"	22 1/4"	35"(MAX.)	150 LB. ± 5%
OVER 18"	32"	30"	46"(MAX.)	200 LB. ± 5%

### STANDARD FRAME AND COVER NOTES

- MATERIAL: ASTM A48 CLASS 30B CAST IRON CONFORMING TO AASHTO DESIGNATION M105-06.
- UNIT MUST WITHSTAND HS-20 WHEEL LOADING, AND CONFORM TO AASHTO DESIGNATION M306-10.
- ALL DIMENSIONS ARE TO BE CONSIDERED MINIMUM WITH THE EXCEPTION OF THE COVER, WHICH MUST CONFORM EXACTLY TO MAINTAIN INTERCHANGEABILITY WITHIN THE COUNTY.
- COATING NOT REQUIRED.
- FRAMES AND COVERS SHALL HAVE MACHINED BEARING SURFACES.
- LOCKING DEVICE MUST BE SITUATED TO ALLOW EASY REMOVAL OF COVER.
- NO LETTERING OTHER THAN ECSD SANITARY WILL BE ALLOWED ON THE EXPOSED SURFACE OF THE COVER.
- \* 1/2" FLANGE THICKNESS AND 7" HEIGHT ACCEPTABLE IF CLASS 35 CAST IRON MATERIAL PROVIDED.

ERIE COUNTY  
DEPT. OF ENVIRONMENT & PLANNING  
DIVISION OF SEWERAGE MANAGEMENT

Rev. 1 4/9/96 REV'D PIPE SIZE TO OVER 18"  
Rev. 2 12/9/96 REV'D <18" DIMENSIONS  
Rev. 3 5/5/03 REV'D FRAME & LOCKS  
Rev. 4 6/28/06 ADDED WEIGHTS TO TABLE  
Rev. 5 12/26/13 REVISED NOTES 1 & 2 TO REFERENCE AASHTO STANDARDS AND ADDED NOTE 8

STD.DETAIL

13

File: D-13

Date: 3/1/91



# STANDARD FRAME AND COVER (PRIVATE SEWER)

## (NOVEMBER 2023)

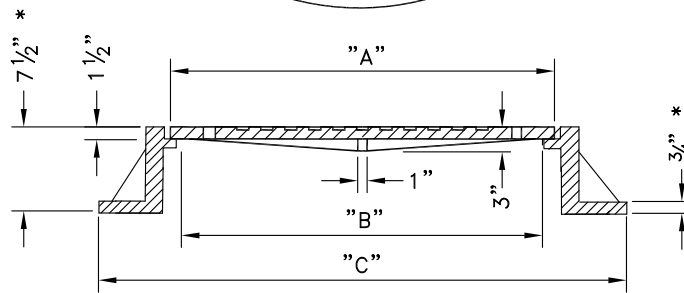
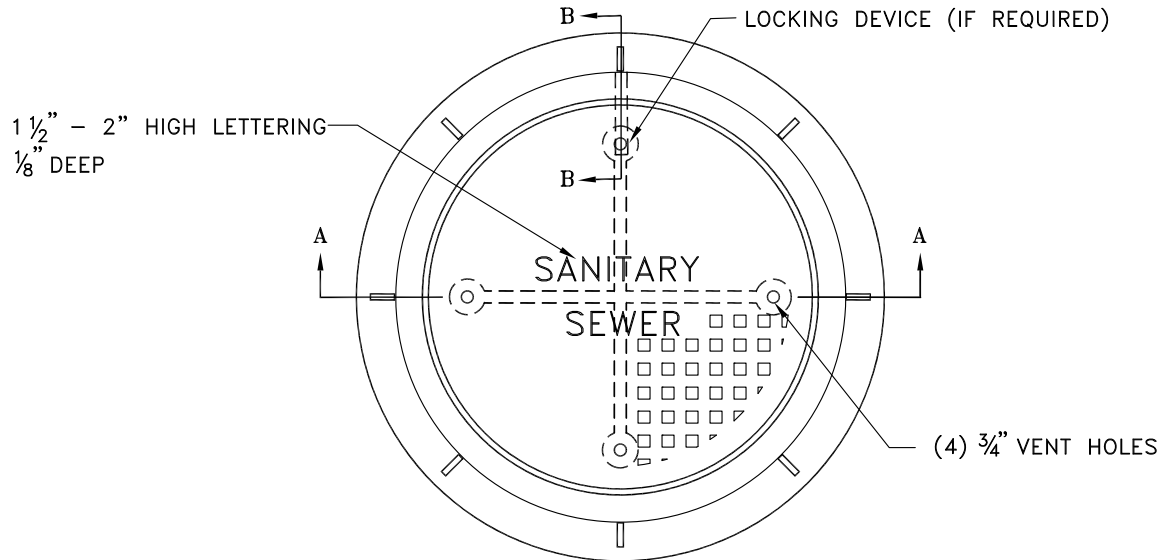

SECTION A-A

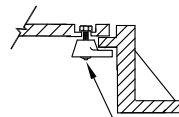

ROTATE CAM TO LOCK COVER (OR EQUAL)

B-B

LOCKING DEVICE

TABLE				
PIPE SIZE	DIMENSION "A"	DIMENSION "B"	DIMENSION "C"	WEIGHT OF COVER
8" THRU 18"	24"	22 1/4"	35"(MAX.)	150 LBS. ± 5%
OVER 18"	32"	30"	46"(MAX.)	200 LBS. ± 5%

### STANDARD FRAME AND COVER NOTES

1. MATERIAL: ASTM A48 CLASS 30B CAST IRON CONFORMING TO AASHTO DESIGNATION M105-06.
2. UNIT MUST WITHSTAND H-20 WHEEL LOADING, AND CONFORM TO AASHTO DESIGNATION M306-10.
3. ALL DIMENSIONS ARE TO BE CONSIDERED MINIMUM WITH THE EXCEPTION OF THE COVER, WHICH MUST CONFORM EXACTLY TO MAINTAIN INTERCHANGEABILITY WITHIN THE COUNTY.
4. COVER WEIGHT 210 LBS. (MAX)
5. COATING NOT REQUIRED.
6. FRAMES AND COVERS SHALL HAVE MACHINED BEARING SURFACES.
7. LOCKING DEVICE MUST BE SITUATED TO ALLOW EASY REMOVAL OF COVER.
8. NO COMMERCIAL "BRAND NAME" LETTERING WILL BE ALLOWED ON THE EXPOSED SURFACE OF THE COVER.
9. \* 1/2" FLANGE THICKNESS AND 7" HEIGHT ACCEPTABLE IF CLASS 35 CAST IRON MATERIAL PROVIDED.

Rev. 1 12/26/13 REVISED NOTES 1 & 2 TO REFERENCE AASHTO STANDARDS & ADDED NOTE 9

Rev. 2

Rev. 3

Rev. 4

File: D-13P

Date: 2/05

STD.DETAIL

13P

**ERIE COUNTY**  
**DEPT. OF ENVIRONMENT & PLANNING**  
**DIVISION OF SEWERAGE MANAGEMENT**

# FORCE MAIN TRENCH DETAIL

## (NOVEMBER 2023)

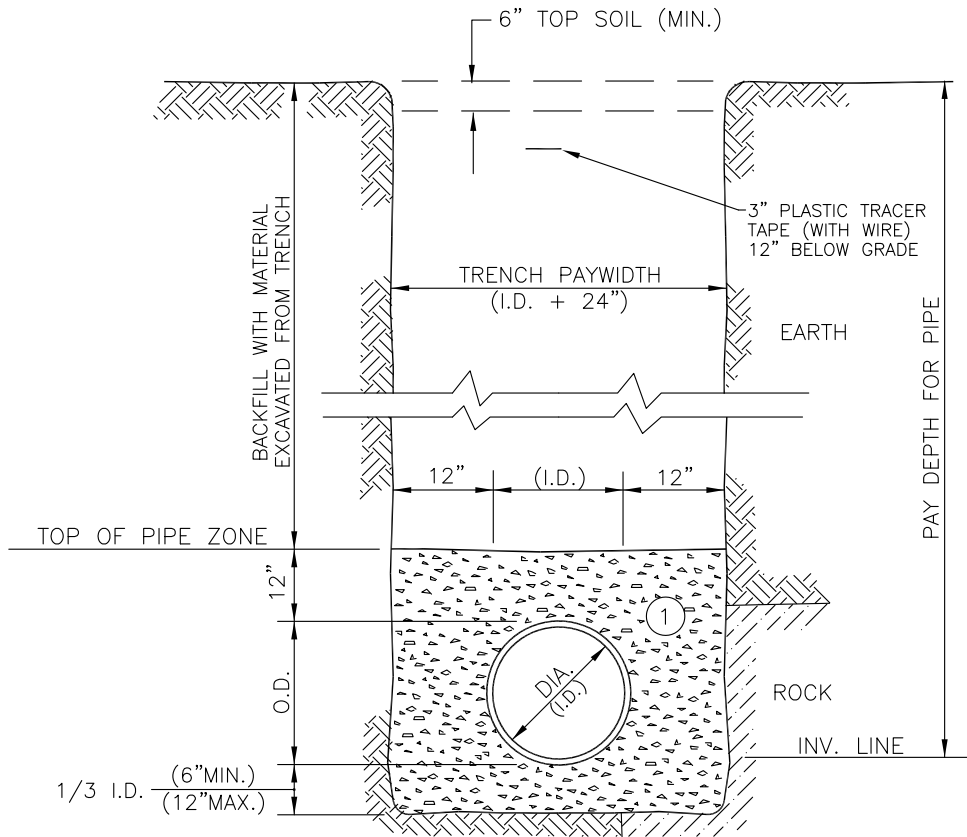

**NOTES:**

- A. PIPE INSTALLATION SHALL BE IN ACCORDANCE WITH MANUFACTURER'S RECOMMENDATIONS. FORCE MAIN MARKERS SHALL BE INSTALLED AT 500 FOOT INTERVALS AND AT POINTS WHERE THE FORCE MAIN DEFLECTS AND/OR CHANGES DIRECTION.
- B. TRENCHING OPERATIONS SHALL INCLUDE ALL NECESSARY DEWATERING.
- C. TRENCH DETAILS ARE ONLY SHOWN FOR PURPOSES OF MATERIAL PLACEMENT AND MAXIMUM PAY LIMITS.
- D. AN OSHA APPROVED MOVABLE PROTECTIVE TRENCH SHIELD SHALL BE USED IN ALL UNSHEETED TRENCH AREAS.

**MATERIALS**

**PIPE BEDDING MATERIAL (NYS DOT LATEST EDITION)**

- ① NO.1 CRUSHED STONE WITH A GRADATION CONFORMING WITH NYSDOT SECTION 703-02. THE CRUSHED STONE SHALL BE WELL GRADED WITH NO PARTICLES LARGER THAN 1" AND HAVING A MAXIMUM GRADATION MEETING THE LIMITS DESCRIBED IN THE SPECIFICATIONS. THE BEDDING SHALL BE COMPACTED IN 6" LIFTS WITH EQUIPMENT ACCEPTABLE TO THE PIPE MANUFACTURER.

File: V:\DSM\Engineering\CAD\Details\November 2023\D-14.dwg, Last saved: 12/5/2023, Plot Date: 12/11/2023, Plot Style: DETAILS.CTB

**ERIE COUNTY**  
**DEPT. OF ENVIRONMENT & PLANNING**  
**DIVISION OF SEWERAGE MANAGEMENT**

<b>Rev. 1</b>	ADDED PIPE INSTALLATION NOTE
5/20/93	
<b>Rev. 2</b>	ADDED TRACER TAPE AND NOTE C&D
2/7/94	
<b>File:</b>	D-14
<b>Date:</b>	3/1/91

**STD.DETAIL**

**14**

# FLAT TOP DETAIL

(NOVEMBER 2023)

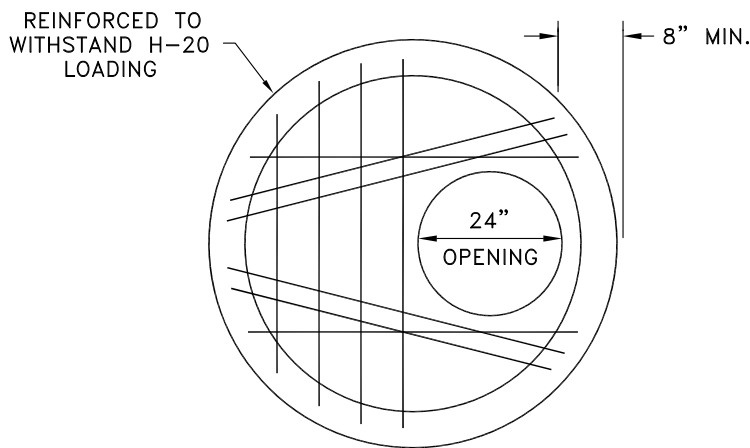

PLAN

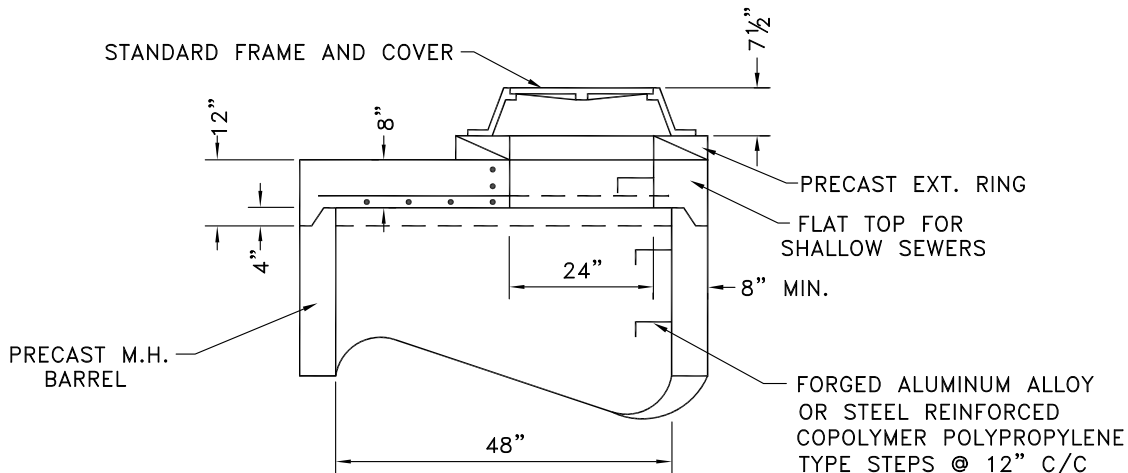

SECTION

**NOTE:**  
 FLAT TOP MANHOLES WILL ONLY BE PERMITTED FOR SHALLOW SEWERS.  
 5.5 FEET OR LESS DEPTH RIM TO INVERT.

File: V:\USMA\Engineering\CAD\Details\November 2023\0-15.dwg, Last saved: 12/5/2023, Plot Date: 12/11/2023, Plot Style: DETAILS.CTB

**ERIE COUNTY**  
**DEPT. OF ENVIRONMENT & PLANNING**  
**DIVISION OF SEWERAGE MANAGEMENT**

Rev. 1	ADDED NOTE: FLAT TOP MH
11/5/99	
Rev. 2	REVISED FLAT TOP MH NOTE AND MH STEPS NOTE
12/01	
File:	D-15
Date:	3/1/91

**STD.DETAIL**

15

# WATER TIGHT FRAME AND COVER

(NOVEMBER 2023)

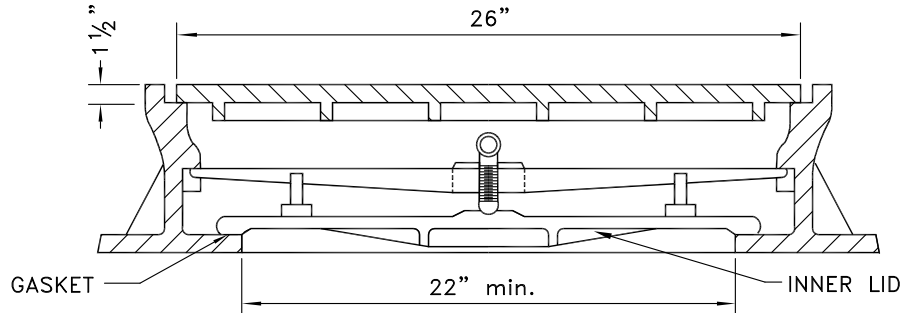

### WATER TIGHT FRAME AND COVER NOTES

1. MATERIAL: ASTM A48 CLASS 30B CAST IRON CONFORMING TO AASHTO DESIGNATION M105-06.
2. UNIT MUST WITHSTAND H-20 WHEEL LOADING, AND CONFORM TO AASHTO DESIGNATION M306-10.
3. ALL DIMENSIONS ARE TO BE CONSIDERED MINIMUM WITH THE EXCEPTION OF THE COVER, WHICH MUST CONFORM EXACTLY TO MAINTAIN INTERCHANGEABILITY WITHIN THE COUNTY.
4. WATER TIGHT MANHOLE UNITS SHALL HAVE 4" STEEL VENT PIPE ASSEMBLY AS PER MANHOLE VENT DETAIL.
4. FRAMES AND COVERS SHALL HAVE MECHANICAL BEARING SURFACES.
6. COVERS SHALL BE SOLID WITH NON-PENETRATING PICKHOLES.
7. NO COMMERCIAL "BRAND NAME" LETTERING WILL BE ALLOWED ON THE EXPOSED SURFACE OF THE COVER.
8. COVER TO BEAR THE INSCRIPTION "ECSD SANITARY", EXCEPT FOR PRIVATE SYSTEMS.
9. THE FRAME SHALL BE PROVIDED WITH 6 HOLES ON FLANGE TO ACCEPT 1/2" Ø ANCHOR BOLTS.

File: V:\DSM\Engineering\CAD\Details\Details November 2023\D-16.dwg, Last saved: 12/5/2023, Plot Date: 12/12/2023, Plot Style: DETAILS.CTB

**ERIE COUNTY**  
**DEPT. OF ENVIRONMENT & PLANNING**  
**DIVISION OF SEWERAGE MANAGEMENT**

Rev. 1	2/7/94 ADDED NOTES 7 AND 8
Rev. 2	6/05 ADDED NOTE 9
Rev. 3	12/26/13 REVISED NOTES 1 & 2 TO REFERENCE AASHTO STANDARDS

File: D-16 Date: 3/1/91

STD.DETAIL

16

# STANDARD MANHOLE STEP (NOVEMBER 2023)

SECTION OF STEP TO BE EMBEDDED IN WALL SHALL BE PAINTED WITH APPROVED BITUMASTIC PAINT.

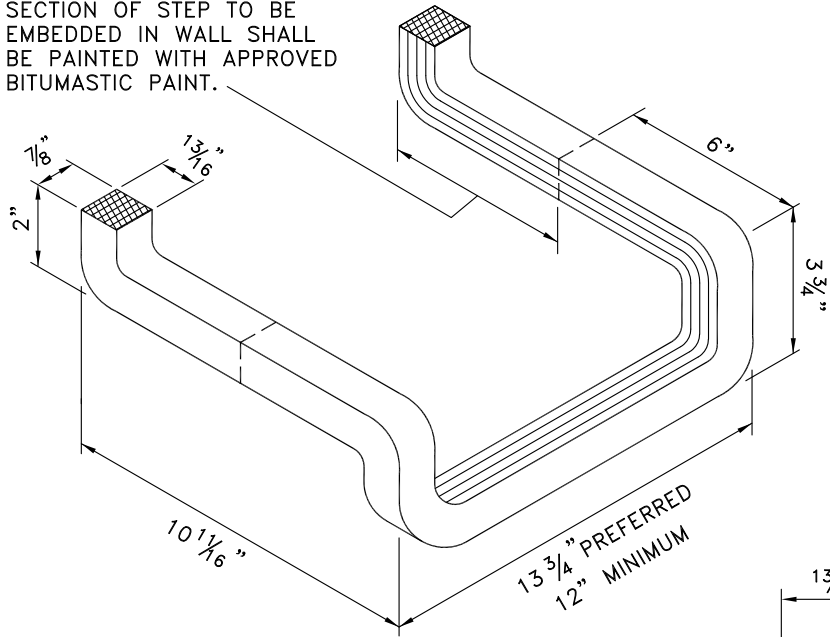

(DROP FRONT TYPE)

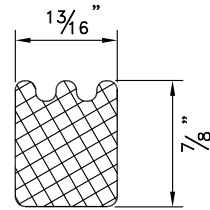

TYPICAL SECTION

**NOTES:**

1. MANHOLE STEPS SHALL BE OF FORGED ALUMINUM ALLOY.
2. AN ACCEPTABLE ALTERNATE IS THE STEEL REINFORCED COPOLYMER POLYPROPYLENE MANHOLE STEP.
3. THE STEPS SHALL BE EMBEDDED IN THE WALLS OF THE CONCRETE MANHOLE BARREL WHILE THE MANHOLE IS BEING CAST OR SECURELY GROUTED IN PLACE AFTER CASTING.

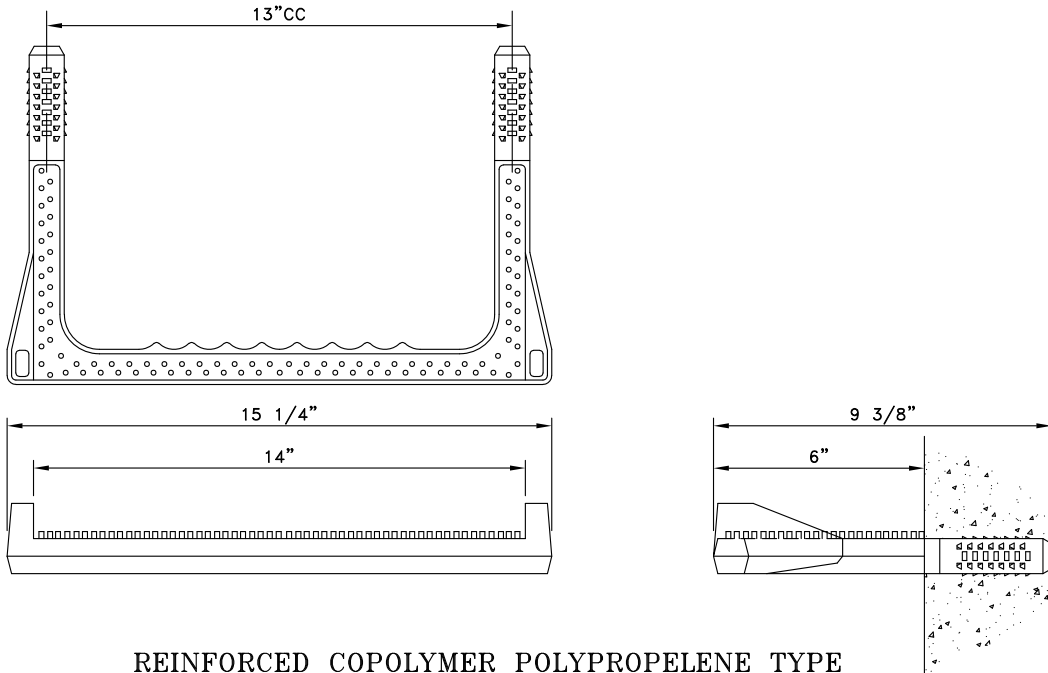

REINFORCED COPOLYMER POLYPROPELENE TYPE

**ERIE COUNTY  
DEPT. OF ENVIRONMENT & PLANNING  
DIVISION OF SEWERAGE MANAGEMENT**

Rev. 1	ADDED REINFORCED COLPOLYMER TYPE STEP
12/9/96	

Rev. 2	
--------	--

File: D-17	Date: 3/1/91
------------	--------------

STD.DETAIL

17

# INSIDE DROP PIPE (NOVEMBER 2023)

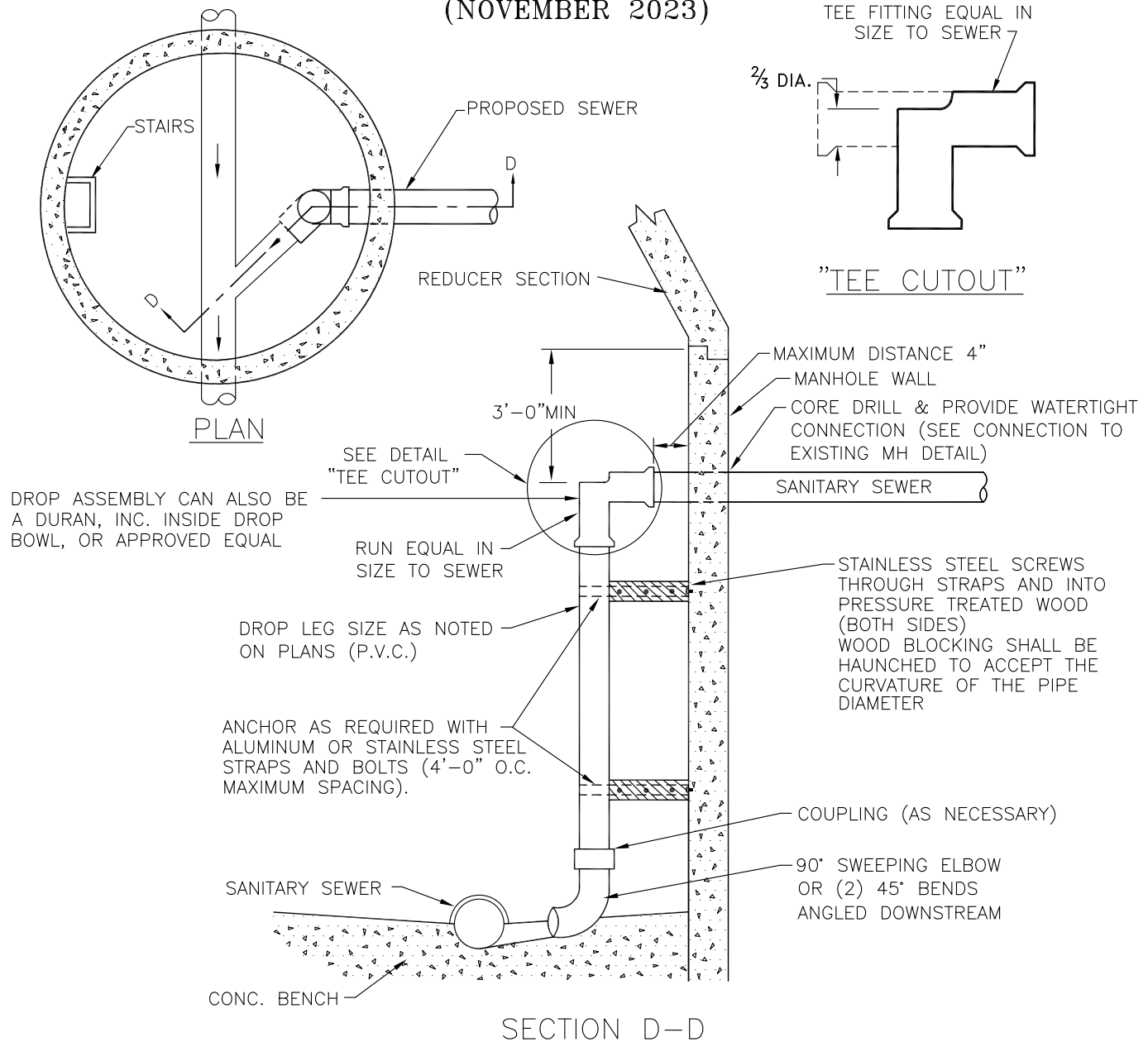

**NOTES:**

1. A DROP PIPE SHALL BE PROVIDED FOR A SEWER ENTERING A MANHOLE AT AN ELEVATION OF 24 INCHES OR MORE ABOVE THE MANHOLE INVERT. ONLY INSIDE DROP ASSEMBLIES WILL BE ALLOWED.
2. INSIDE DROP LEG SHALL BE INSTALLED ON MANHOLE WALL LOCATED AS SHOWN OR AS APPROVED BY ECDSM
3. ON NEW CONSTRUCTION INSIDE DROP ASSEMBLIES SHALL BE INSTALLED IN MANHOLES NOT LESS THAN 5'-0" IN DIAMETER.

PIPE SIZE	MANHOLE I. D.
18"	5'-0"
21" - 27"	6'-0"
30" - 36"	8'-0"

**REVISIONS**

4/24/93	CHANGED TEE CUTOUT
6/1/93	BENCH CONFIGURATION & REDUCER SECTION CLEARANCE
2/7/94	CHANGED MAX. DIST. FROM MH TO TEE ADDED STAINLESS STEEL BOLTS, SCREWS
7/13/99	CHANGED NOTE NO.2, ADD SIZE CHART
12/22/00	REVISED TEE CUTOUT & SPACERS NOTE
6/23/05	ADDED DURAN, INC. DROP BOWL NOTE

**ERIE COUNTY  
DEPT. OF ENVIRONMENT & PLANNING  
DIVISION OF SEWERAGE MANAGEMENT**

**STD.DETAIL**

**18**

File: D-18      Date: 3/1/91

# MANHOLE VENT DETAIL

(NOVEMBER 2023)

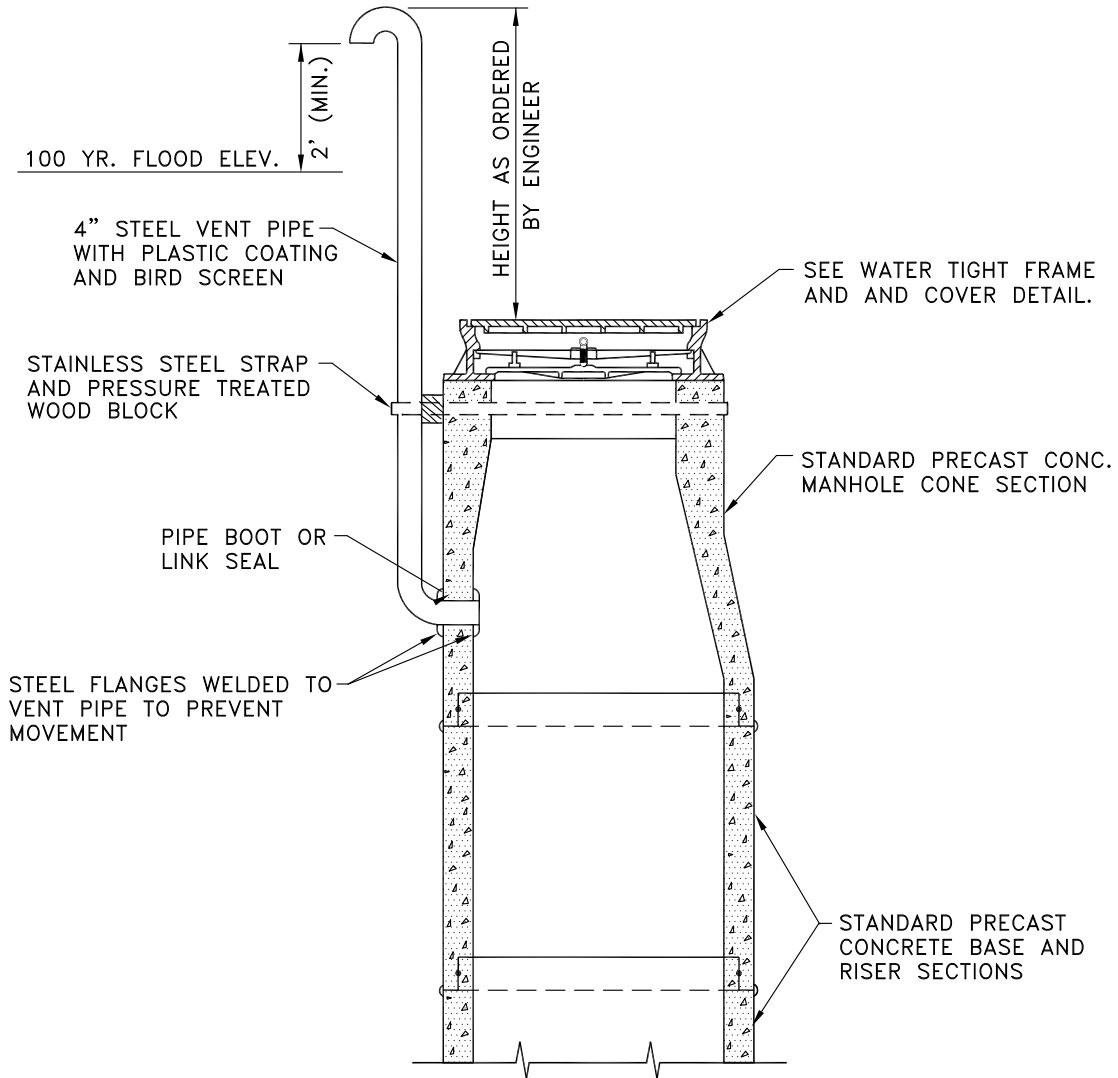

File: V:\DSM\Engineering\CAD\Details\November 2023\D-19.dwg, Last saved: 12/5/2023, Plot Date: 12/12/2023, Plot Style: DETAILS.CTB

**ERIE COUNTY**  
**DEPT. OF ENVIRONMENT & PLANNING**  
**DIVISION OF SEWERAGE MANAGEMENT**

Rev. 1	ADDED BIRD SCREEN & PRESSURE TREATED WOOD TO VENT PIPE, ADDED 2' (MIN) DIM. ABOVE 100yr FLOOD	
2/7/94		
Rev. 2	ADDED PIPE BOOT OR LINK SEAL	
12/01	NOTE TO VENT PIPE	
File:	D-19	Date: 3/1/91

STD.DETAIL  
  
**19**

# TREE REMOVAL AND REPLACEMENT POLICY (NOVEMBER 2023)

## GENERAL CONDITIONS

1. REMOVE AS INDICATED WITH AN ("R") ALL TREES UNDER 8" IN DIAMETER AND OFFER PROPERTY OWNER A REPLACEMENT TREE OF THE SAME SPECIES ON A ONE FOR ONE BASIS.
2. REMOVE AS INDICATED WITH AN ("R") ALL TREES 8" IN DIAMETER AND OVER, THEN OFFER THE PROPERTY OWNER REPLACEMENT TREES OF THE SAME SPECIES ON A TWO FOR ONE BASIS.
3. TREES MARKED "R1" SHALL BE REPLACED ON A ONE FOR ONE BASIS REGARDLESS OF SIZE. TREES MARKED "R2" SHALL NOT BE REPLACED AT ALL. ALL "R2" AREAS SHALL BE GRADED, TOPSOILED AND HYDROSEEDDED UNLESS OTHERWISE NOTED.
4. THE CONTRACTOR SHALL CONSIDER IN HIS BID ALL COSTS ASSOCIATED WITH THE REMOVAL OF EXISTING TREES AND PROVIDING AND PLANTING THE REPLACEMENT TREES (MIN 3" DIA). NO ADDITIONAL COMPENSATION WILL BE PROVIDED.
5. THE CONTRACTOR SHALL, FOR THOSE TREES SO MARKED ("T") TUNNEL, BID THE ITEM TO TUNNEL OR BORE AND JACK THE SEWER PAST THE TREE.
6. IF THE TREE IS OVER 15" IN DIAMETER AND THE TRENCH IS OVER 8' FROM THE TRUNK BUT STILL WITHIN THE DRIP LINE, THE TREES CROWN MUST BE PRUNED BACK TO COMPENSATE FOR LOSS OF ROOT STRUCTURE.
7. IF THE PROPERTY OWNER AGREES IN WRITING, HEALTHY TREES MAY BE REMOVED FROM THE EASEMENT REGARDLESS OF VARIETY OR SIZE.
8. THE CONTRACTOR SHALL RETAIN THE SERVICES OF A QUALIFIED NURSERY MAN DURING THE LIFE OF THE CONTRACT.

## SPECIAL CONDITIONS

1. FOR AREAS WITHIN THE HIGHWAY RIGHT-OF-WAY THE CONTRACTOR SHALL REMOVE ALL TREES INDICATED WITH AN "R" AND PROVIDE REPLACEMENT TREES AS DESCRIBED IN THE "GENERAL CONDITIONS". THE PLANTING OF THE REPLACEMENT TREES SHALL BE OUTSIDE THE RIGHT-OF-WAY LINE ONLY AFTER THE CONTRACTOR RECEIVES A RELEASE FROM THE PROPERTY OWNER ALLOWING THE PLANTING ON THEIR PROPERTY. THE NEW REPLACEMENT TREE(S) SHALL BE PLANTED IN AN AREA NEAR THE HIGHWAY RIGHT-OF-WAY AT A MINIMUM DISTANCE OF 8'-0" AWAY FROM THE INSTALLED PIPELINE. ALL ADDITIONAL SITE RESTORATION CAUSED BY THE NEW TREE PLANTING SHALL BE THE RESPONSIBILITY OF THE CONTRACTOR AND SHALL BE COMPLETED AT NO ADDITIONAL COST TO THE COUNTY.

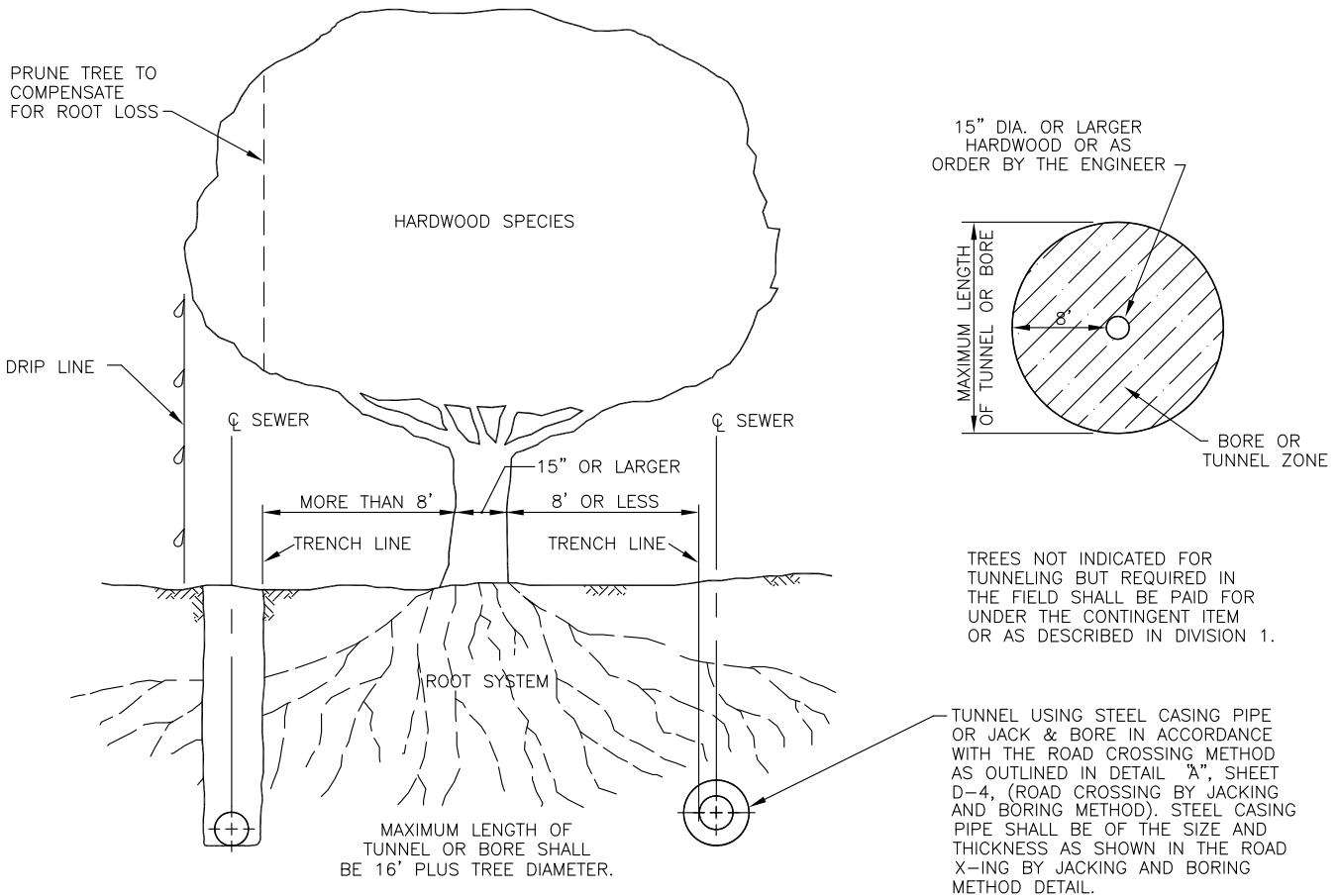

**ERIE COUNTY**  
DEPT. OF ENVIRONMENT & PLANNING  
DIVISION OF SEWERAGE MANAGEMENT

Rev. 1	REVISED NOTES FOR 8" TO OVER	<b>STD.DETAIL</b>
7/12/99	CONDITIONS TO GENERAL & SPECIAL	
Rev. 2		
File:	D-20	Date: 3/1/91

20



# Tap Saddle Install on CIPPL Pipes

(NOVEMBER 2023)

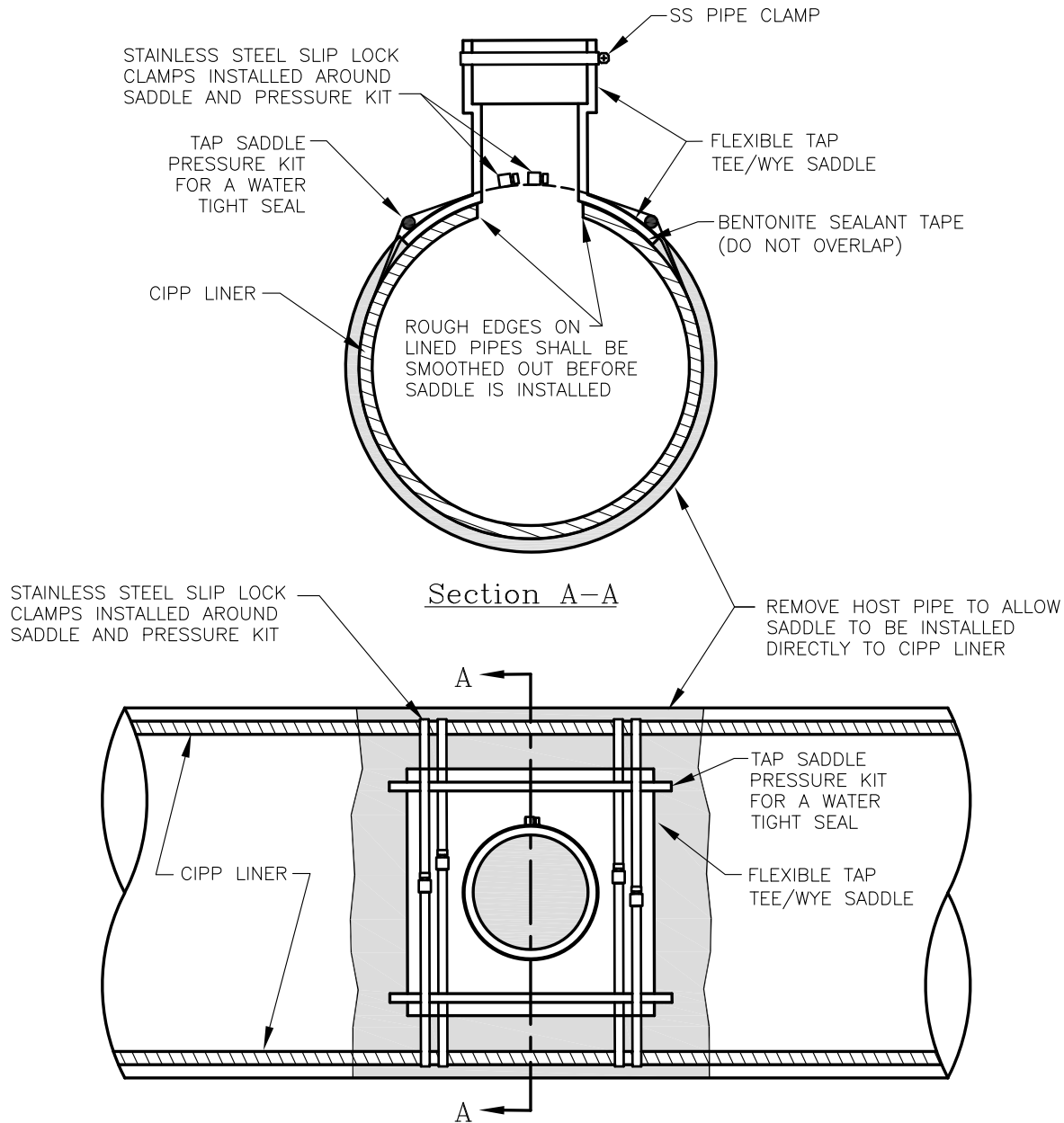

NOTES:

- 1) FLEXIBLE TAP SADDLE SHALL BE FERNCO MODEL TST-4, TST-6, TSW-4, OR TSW-6, WITH TSPK-46 PRESSURE KIT, OR APPROVED EQUIVALENT.
- 2) FOR NEW LATERAL TAP-IN CONNECTIONS, LINED PIPE SHALL BE CORE DRILLED.
- 3) WHERE EXISTING LATERAL TAPS ARE LESS THAN 6" DIAMETER, CONNECTION SHALL BE MODIFIED/ENLARGED TO 6" DIAMETER UNLESS APPROVED BY ENGINEER.

ERIE COUNTY  
DEPT. OF ENVIRONMENT & PLANNING  
DIVISION OF SEWERAGE MANAGEMENT

Rev. 1	
Rev. 2	
Drawn by: W.J.L.	Scale: NTS
File: D-21&22B	Date: NOV-23

STD. DETAIL

21&22B

# TYPICAL HOUSE SERVICE DETAIL (NEW BUILDS)

## (NOVEMBER 2023)

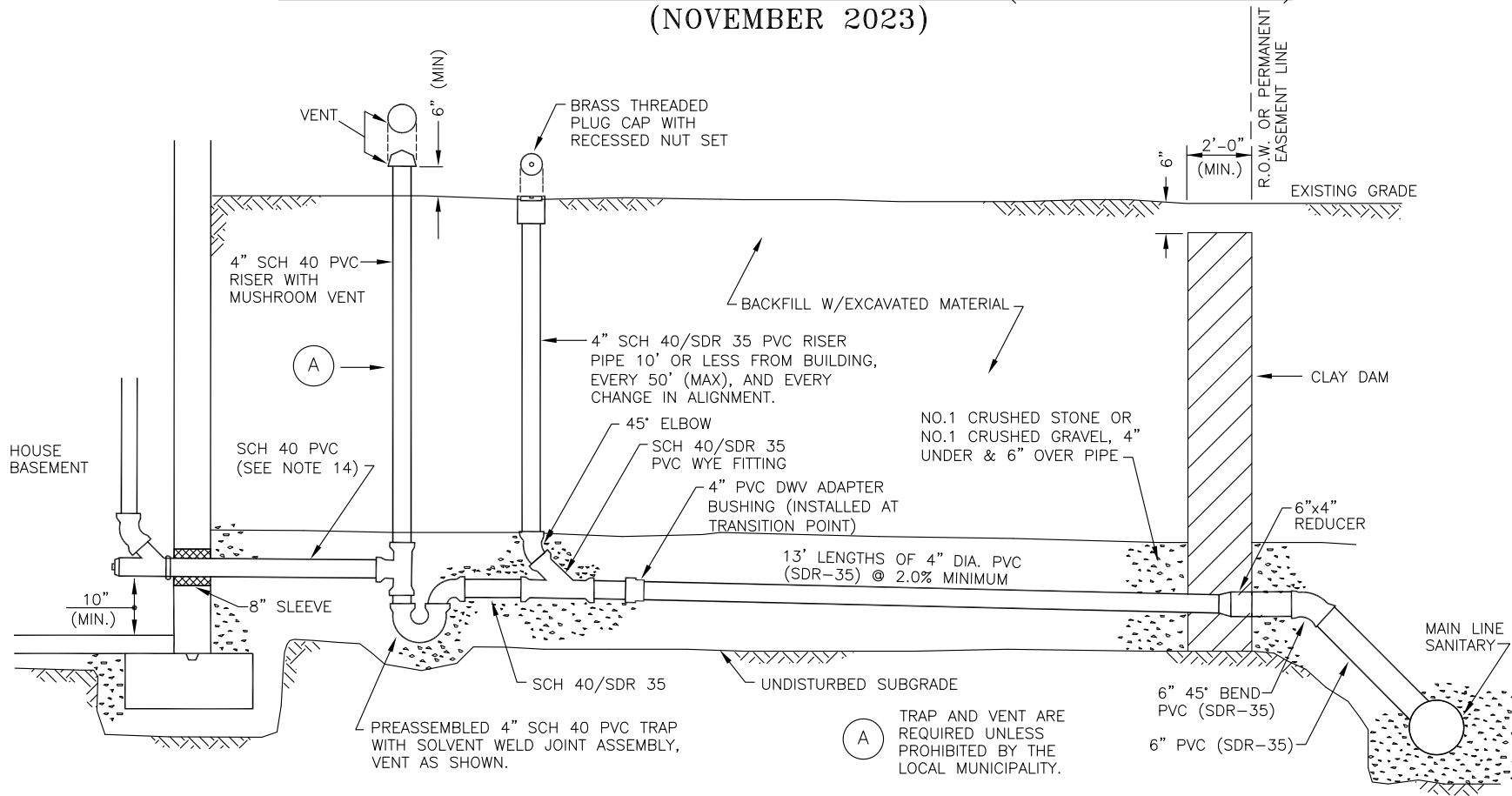

**NOTES:**

1. NO INSPECTION WILL BE PROVIDED WITHOUT A PERMIT. INSPECTIONS REQUIRE 48 HR. ADVANCE NOTICE FOR SCHEDULING.
2. ALL WORK MUST BE INSPECTED BY A COUNTY INSPECTOR.
3. PVC PIPE MATERIAL SHALL BE MANUFACTURED IN ACCORDANCE WITH THE REQUIREMENTS OF THE LATEST ASTM SPECIFICATION D-3033/D-3034.
4. A MANUAL VALVE SHALL BE INSTALLED ON BASEMENT LAUNDRY DRAIN LINE.
5. CLEANOUTS MUST BE INSTALLED IN LAWN AREAS, NOT IN SIDEWALK OR DRIVEWAY AREAS, PREFERABLY BETWEEN THE CURB OR EDGE OF PAVEMENT AND THE SIDEWALK.
6. SELECT BACKFILL REQUIRED UNDER PAVED AREAS.
7. CONCRETE ENCASUREMENT IF COVER DEPTH IS LESS THAN 4'-0" UNDER PAVED AREAS.
8. AN 8"x6" WYE WITH 6" PVC TO 6" 45° BEND, THEN 6"x4" REDUCER IS USED.
9. A 6" CLEANOUT IS REQUIRED AT R.O.W. WHENEVER THE MAIN SEWER IS UNDER THE PAVEMENT LIMITS OR AT FAR SIDE OF PAVEMENT.
10. ANY EXCAVATION TO BE LEFT OPEN OVERNIGHT SHALL BE COMPLETELY ENCLOSED IN FENCING, OR WHERE NECESSARY, COVERED WITH STEEL PLATES.
11. DOWN SPOUTS, SUMP PUMPS, AND FOOTING DRAINS ARE NOT PERMITTED TO BE CONNECTED TO THE HOUSE LATERAL.
12. NO CONNECTION SHALL BE MADE UNTIL BUILDING ROOF IS ERECTED AND BASEMENT FLOOR IS POURED.
13. SEPTIC TANKS MUST BE ABANDONED PER NYSDEC APPROVED METHODS.
14. IF THE PIPE EXITING THE HOME IS CAST IRON, A MISSION COUPLING IS REQUIRED BEFORE TRAP.

File: V:\DSM\Engineering\CAD\Details\Details November 2023\D-21.dwg, Last saved: 3/15/2024, Plot Date: 3/15/2024, Plot Style: DETAILS.CTB

**ERIE COUNTY**  
**DEPT. OF ENVIRONMENT & PLANNING**  
**DIVISION OF SEWERAGE MANAGEMENT**

Rev. 11/08	ADDED PVC TRAP AND SLEEVE
Rev. 01/12	REVISED 4" CAST IRON TRAP
Rev. 10/21	REMOVED VENT, RISER, AND TRAP ASSEMBLY
Rev. 11/23	ADDED VENT, RISER, TRAP ASSEMBLY & (A)
Rev. 3/24	CHANGED VENT, RISER, TRAP TO SCH 40

**File:** d-21      **Date:** 3/1/91

**STD. DETAIL**

21

# TYPICAL HOUSE SERVICE DETAIL (REPAIR)

## (NOVEMBER 2023)

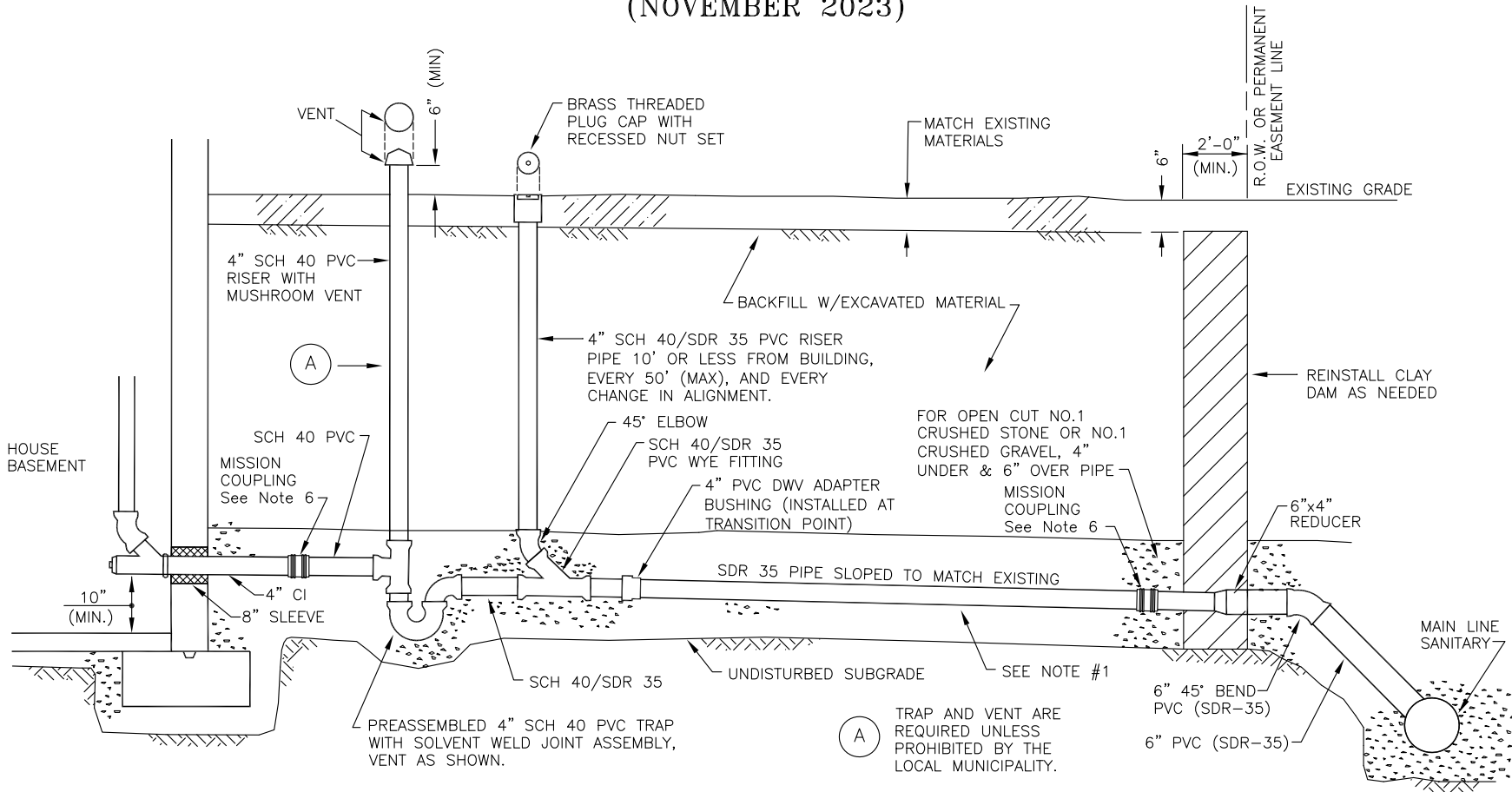

- NOTES:**
1. ACCEPTABLE INSTALLATION METHODS:  
 A. OPEN CUT – USE SCH 40/SDR-35 PVC  
 B. PIPE BURSTING – USE HDPE PIPE  
 C. CURED IN PLACE PIPE – CIPP
  2. PERMIT & INSPECTION ARE REQUIRED.  
 48 HOUR NOTICE IS REQUIRED.
  3. A. CLEANOUT LOCATIONS IN ACCORDANCE WITH THE INTERNATIONAL PLUMBING CODE  
 B. EVERY EFFORT SHALL BE TAKEN TO INSTALL CLEAN-OUTS IN LAWN AREAS.
  4. FOR OPEN CUT – SELECT FILL IS REQUIRED UNDER PAVED AREAS.
  5. DOWN SPOUTS, SUMP PUMPS, AND FOOTING DRAINS ARE NOT PERMITTED TO BE CONNECTED TO THE HOUSE LATERAL.
  6. COUPLING SHALL BE MISSION TYPE OR APPROVED EQUAL, LOCATION DEPENDS ON REPAIR.
  7. FOR CIPP – A POST INSTALLATION CCTV WILL BE REQUIRED.
  8. FOR CLEAN-OUTS WITH HDPE EITHER FUSE THE PIPE OR USE MISSION COUPLINGS.
  9. FOR BURSTING: FILL SLEEVE VOID WITH SAND, PEA GRAVEL, OR EQUAL. PLUG ENDS WITH MORTAR OR EQUAL.
  10. SITE SAFETY IS THE RESPONSIBILITY OF THE CONTRACTOR.

**ERIE COUNTY**  
**DEPT. OF ENVIRONMENT & PLANNING**  
**DIVISION OF SEWERAGE MANAGEMENT**

Rev. 02/18	ADDED "REPAIR" TO ORIGINAL DETAIL 21 TITLE, REMOVED NOTES 4, 7, 8, & 9 TO CREATE DETAIL 21a
Rev. 02/20	CHANGED CAULDER TO MISSION COUPLINGS, CHANGED NOTES 1-11
Rev. 10/21	ADDED (A) NOTE
Rev. 3/24	CHANGED VENT, RISER, TRAP TO SCH 40
<b>File:</b>	<b>D-21a</b>
<b>Date:</b>	<b>1/18/18</b>

STD. DETAIL

21a

# TYPICAL COMMERCIAL SERVICE WITHOUT BASEMENT DETAIL (NEW BUILDS) (NOVEMBER 2023)

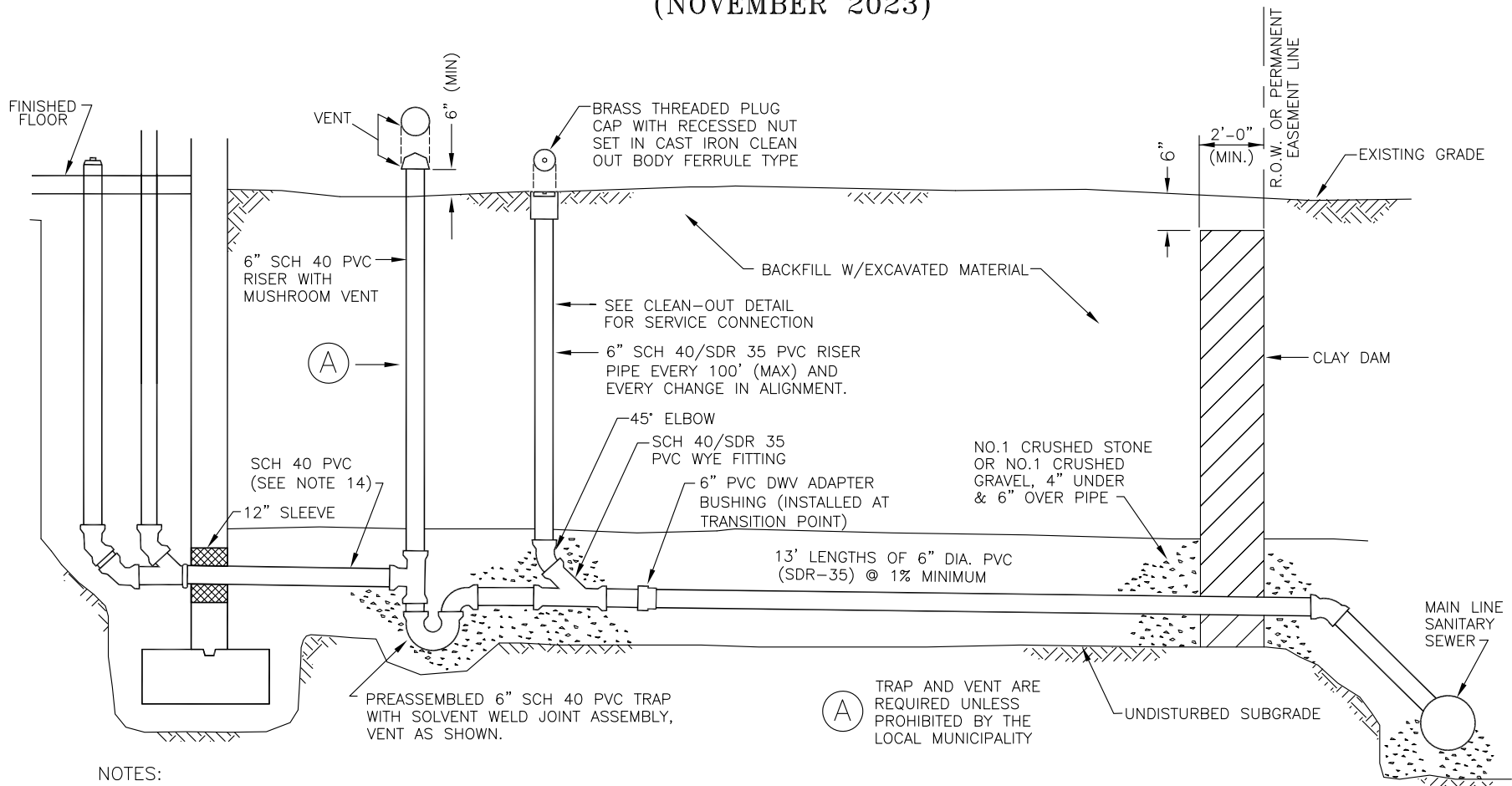

## NOTES:

- NO INSPECTION WILL BE PROVIDED WITHOUT A PERMIT. INSPECTIONS REQUIRE 48 HR. ADVANCE NOTICE FOR SCHEDULING.
- ALL WORK MUST BE INSPECTED BY A COUNTY INSPECTOR.
- PVC PIPE MATERIAL SHALL BE MANUFACTURED IN ACCORDANCE WITH THE REQUIREMENTS OF THE LATEST ASTM SPECIFICATION D-3033/D-3034.
- CLEANOUTS MUST BE INSTALLED IN LAWN AREAS, NOT IN SIDEWALK OR DRIVEWAY AREAS, PREFERABLY BETWEEN THE CURB OR EDGE OF PAVEMENT AND THE SIDEWALK.
- SELECT BACKFILL REQUIRED UNDER PAVED AREAS.
- CONCRETE ENCASEMENT IF COVER DEPTH IS LESS THAN 4'-0" UNDER PAVED AREAS.
- MIN. DEPTH OF COVER 3'-0".
- CLEANOUT MEASUREMENTS SHALL START FROM CENTERLINE OF MAIN SEWER FOR NEARSIDE LATERALS AND FROM THE 6" CLEANOUT FOR FAR SIDE CONNECTIONS. A CLEANOUT MAY BE REQUIRED FOR ANY ABRUPT CHANGES IN LATERAL DIRECTION FLOW.
- A 6" CLEANOUT IS REQUIRED AT R.O.W. WHENEVER THE MAIN SEWER IS UNDER THE PAVEMENT LIMITS OR AT FAR SIDE OF PAVEMENT.
- SEPTIC TANKS MUST BE ABANDONED PER NYSDEC APPROVED METHODS.
- ANY EXCAVATION TO BE LEFT OPEN OVERNIGHT SHALL BE COMPLETELY ENCLOSED IN FENCING, OR WHERE NECESSARY, COVERED WITH STEEL PLATES.
- DOWN SPOUTS, SUMP PUMPS, AND FOOTING DRAINS ARE NOT PERMITTED TO BE CONNECTED TO THE LATERAL.
- NO CONNECTION SHALL BE MADE UNTIL BUILDING ROOF IS ERECTED.
- IF CAST IRON IS USED EXITING THE BUILDING, A MISSION COUPLING IS REQUIRED BEFORE THE TRAP.

ERIE COUNTY  
DEPT. OF ENVIRONMENT & PLANNING  
DIVISION OF SEWERAGE MANAGEMENT

Rev. 1/07	REMOVED OLD NOTES 2 AND 18 ADDED 1% MIN. TO SERVICE PIPE DETAIL
Rev. 11/08	ADDED SLEEVE AND PVC-SDR 35
Rev. 1/12	REVISED 6" CAST IRON TRAP NOTE
Rev. 10/21	REMOVED VENT, RISER, AND TRAP ASSEMBLY
Rev. 11/23	ADDED VENT, RISER, TRAP ASSEMBLY & (A)
Rev. 3/24	CHANGED VENT, RISER, TRAP ASSEMBLY SCH 40

File: D-22 Date: 3/1/91

STD. DETAIL

22

# TYPICAL COMMERCIAL SERVICE WITH BASEMENT DETAIL (NEW BUILDS)

(NOVEMBER 2023)

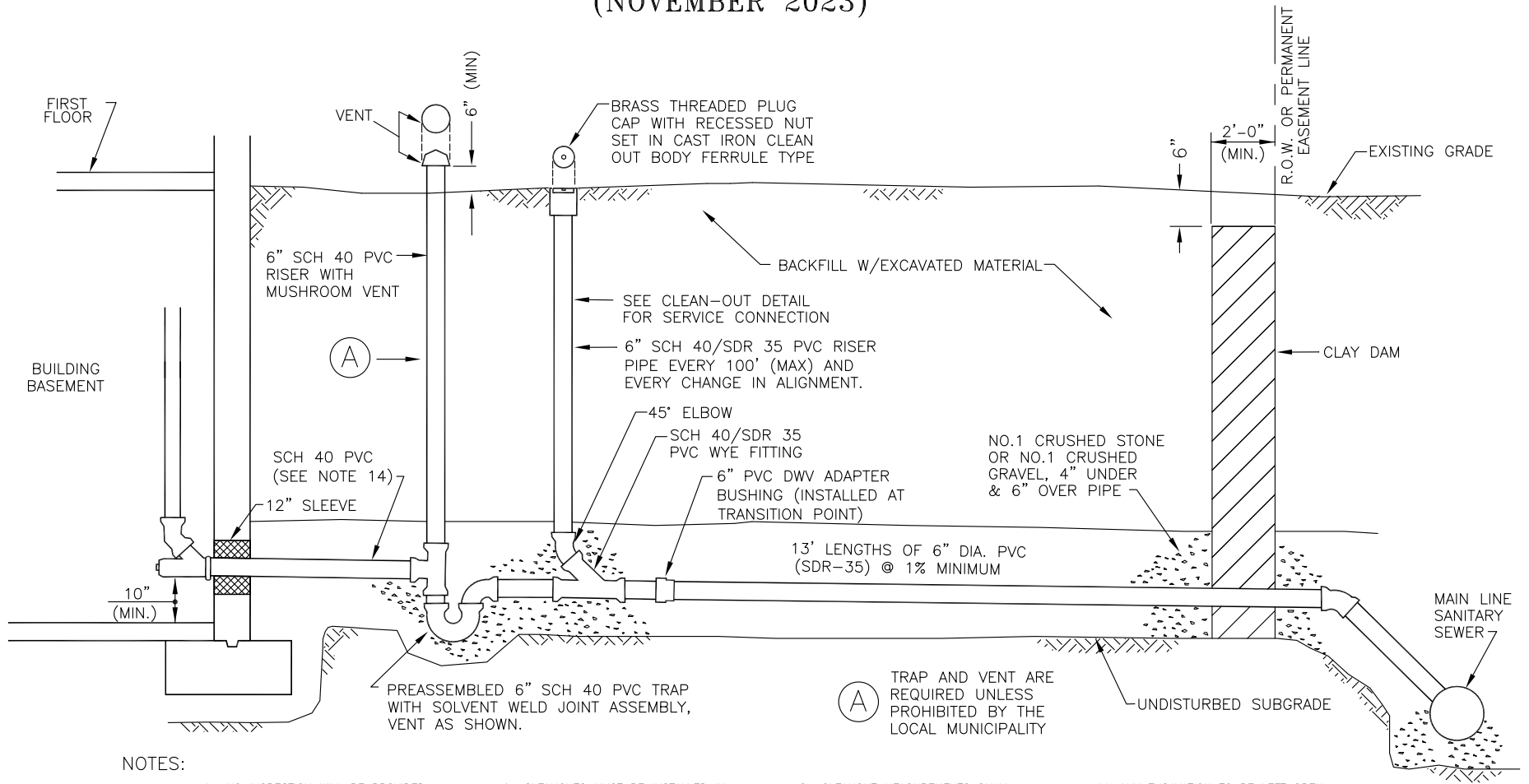

**NOTES:**

1. NO INSPECTION WILL BE PROVIDED WITHOUT A PERMIT. INSPECTIONS REQUIRE 48 HR. ADVANCE NOTICE FOR SCHEDULING.
2. ALL WORK MUST BE INSPECTED BY A COUNTY INSPECTOR.
3. PVC PIPE MATERIAL SHALL BE MANUFACTURED IN ACCORDANCE WITH THE REQUIREMENTS OF THE LATEST ASTM SPECIFICATION D-3033/D-3034.
4. CLEANOUTS MUST BE INSTALLED IN LAWN AREAS, NOT IN SIDEWALK OR DRIVEWAY AREAS, PREFERABLY BETWEEN THE CURB OR EDGE OF PAVEMENT AND THE SIDEWALK.
5. SELECT BACKFILL REQUIRED UNDER PAVED AREAS.
6. CONCRETE ENCASEMENT IF COVER DEPTH IS LESS THAN 4'-0" UNDER PAVED AREAS.
7. MIN. DEPTH OF COVER 3'-0".
8. CLEANOUT MEASUREMENTS SHALL START FROM CENTERLINE OF MAIN SEWER FOR NEARSIDE LATERALS AND FROM THE 6" CLEANOUT FOR FAR SIDE CONNECTIONS. A CLEANOUT MAY BE REQUIRED FOR ANY ABRUPT CHANGES IN LATERAL DIRECTION FLOW.
9. A 6" CLEANOUT IS REQUIRED AT R.O.W. WHENEVER THE MAIN SEWER IS UNDER THE PAVEMENT LIMITS OR AT FAR SIDE OF PAVEMENT.
10. SEPTIC TANKS MUST BE ABANDONED PER NYSDEC APPROVED METHODS.
11. ANY EXCAVATION TO BE LEFT OPEN OVERNIGHT SHALL BE COMPLETELY ENCLOSED IN FENCING, OR WHERE NECESSARY, COVERED WITH STEEL PLATES.
12. DOWN SPOUTS, SUMP PUMPS, AND FOOTING DRAINS ARE NOT PERMITTED TO BE CONNECTED TO THE LATERAL.
13. NO CONNECTION SHALL BE MADE UNTIL BUILDING ROOF IS ERECTED.
14. IF CAST IRON IS USED EXITING THE BUILDING, A MISSION COUPLING IS REQUIRED BEFORE THE TRAP.

**ERIE COUNTY**  
**DEPT. OF ENVIRONMENT & PLANNING**  
**DIVISION OF SEWERAGE MANAGEMENT**

Rev. 11/08	ADDED 12" SLEEVE AND PVC-SDR 35
Rev. 1/12	REVISED 6" CAST IRON TRAP NOTE
Rev. 1/18	ADDED (A) NOTE TO EXISTING VENT AND TRAP
Rev. 10/21	REMOVED VENT, RISER, TRAP ASSEMBLY & (A)
Rev. 11/23	ADDED VENT, RISER, TRAP ASSEMBLY & (A)
Rev. 3/24	CHANGED VENT, RISER, TRAP ASSEMBLY SCH 40

**File:** D-22a      **Date:** 4/21/06

**STD. DETAIL**

22a

File: V:\DSM\Engineering\CAD\Details\Details November 2023\D-22a.dwg, Last saved: 3/15/2024, Plot Date: 3/15/2024, Plot Style: DETAILS.CTB

# TYPICAL COMMERCIAL SERVICE REPAIR DETAIL – REPAIR (NOVEMBER 2023)

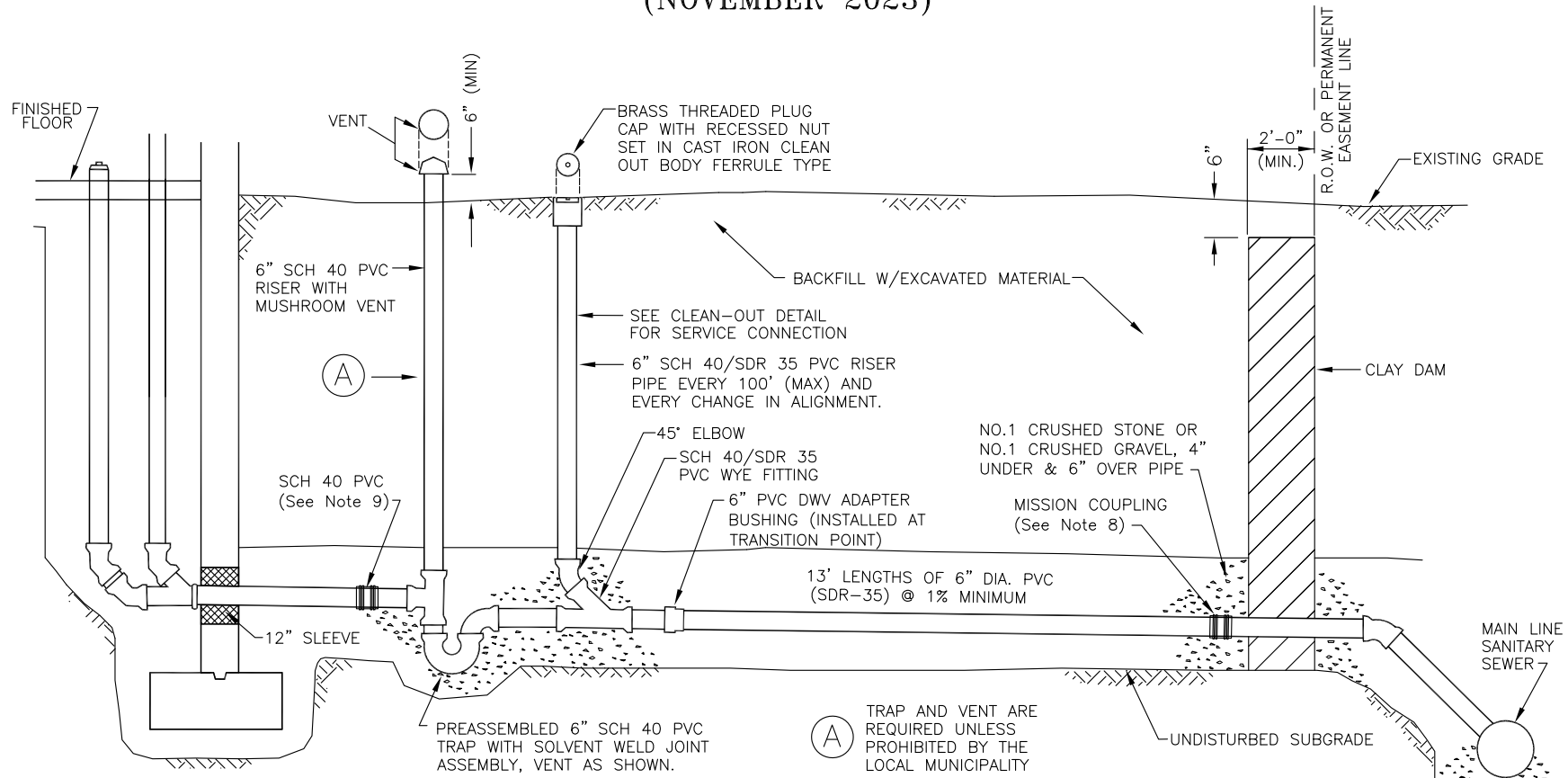

- NOTES:
1. NO INSPECTION WILL BE PROVIDED WITHOUT A PERMIT. INSPECTIONS REQUIRE 48 HR. ADVANCE NOTICE FOR SCHEDULING.
  2. ALL WORK MUST BE INSPECTED BY A COUNTY INSPECTOR.
  3. PVC PIPE MATERIAL SHALL BE MANUFACTURED IN ACCORDANCE WITH THE REQUIREMENTS OF THE LATEST ASTM SPECIFICATION D-3033/D-3034.
  4. SELECT BACKFILL REQUIRED UNDER PAVED AREAS.

5. VENTS AND CLEANOUTS MUST BE INSTALLED IN LAWN AREAS, NOT IN SIDEWALK OR DRIVEWAY AREAS, PREFERABLY BETWEEN THE CURB OR EDGE OF PAVEMENT AND THE SIDEWALK.
5. A 6" CLEANOUT IS REQUIRED AT R.O.W. WHENEVER THE MAIN SEWER IS UNDER THE PAVEMENT LIMITS OR AT FAR SIDE OF OF PAVEMENT.
6. ANY EXCAVATION TO BE LEFT OPEN OVERNIGHT SHALL BE COMPLETELY ENCLOSED IN FENCING, OR WHERE NECESSARY, COVERED WITH STEEL PLATES.

7. DOWN SPOUTS, SUMP PUMPS, AND FOOTING DRAINS ARE NOT PERMITTED TO BE CONNECTED TO THE LATERAL.
8. COUPLING SHALL BE MISSION TYPE, OR APPROVED EQUAL. LOCATION DEPENDS ON REPAIR.
9. IF THE PIPE EXITING THE BUILDING IS CAST IRON, A MISSION COUPLING IS REQUIRED BEFORE THE TRAP.

**ERIE COUNTY  
DEPT. OF ENVIRONMENT & PLANNING  
DIVISION OF SEWERAGE MANAGEMENT**

Rev.	1/18	ADDED "REPAIR" TO ORIGINAL DETAIL 22 TITLE, REMOVED NOTES 6, 7, 8, 10 & 13 TO CREATE DETAIL 22c
Rev.	10/21	ADDED (A) NOTE TO EXISTING VENT & TRAP
Rev.	3/24	CHANGED VENT, RISER, TRAP ASSEMBLY SCH 40
Rev.		

**File: D-22b Date: 1/18/18**

**STD. DETAIL**

**22b**

# CONSTRUCTION SPECIFICATIONS FOR HOUSE LATERALS

## (NOVEMBER 2023)

1. MATERIAL

- a. THICK WALL PVC – D – 3034, SDR-35
- b. EXTRA HEAVY CAST IRON
- c. DUCTILE IRON

2. FAR SIDE CROSSING

- a. LATERALS INSTALLED ACROSS TOWN ROADS MAY BE BY THE OPEN CUT METHOD WHERE ALLOWED BY THE HIGHWAY PERMIT.
- b. LATERALS INSTALLED ACROSS STATE OR COUNTY ROADS SHALL BE BY THE BORING AND JACKING METHOD (UNLESS OTHERWISE NOTED ON THE PLANS) USING A STEEL CASING PIPE. THE CARRIER PIPE SHALL CONFORM WITH THE MATERIAL SPECIFIED OR APPROVED BY THE ENGINEER.
- c. ALL PAVEMENT CROSSINGS (OPEN CUT METHOD) WITH LESS THAN 4'-0" COVER SHALL BE ENCASED WITH 2000 PSI CONCRETE.
- d. ALL FAR SIDE CROSSINGS SHALL BE INSTALLED UP TO ONE (1) FOOT OF THE R.O.W. LINE.
- e. THE CONTRACTOR SHALL SUPPLY A 2" X 4" WOOD MARKER EXTENDING FROM THE END OF THE CROSSING TO ONE FOOT BELOW GRADE. ALSO, RECORDS SHALL BE KEPT AS TO THE DEPTH OF THE HOUSE SERVICE AND A MINIMUM OF THREE (3) TIES SHALL BE ESTABLISHED FOR THE LOCATION OF THE SERVICE.
- f. LATERALS SHALL BE LAID AT A 2.0% MINIMUM GRADE. IN CASES OF A SHALLOW SEWER, A 1.0% SLOPE MAY BE APPROVED BY THE ENGINEER.

3. NEAR SIDE SERVICES

- a. THE CONTRACTOR SHALL SUPPLY WYE BRANCHES OF THE SAME MATERIAL AND CLASS AS THE SEWER MAIN.
- b. THE LOCATION OF THE WYE BRANCHES WILL BE DETERMINED BY THE CONTRACTOR AND ENGINEER IN THE FIELD AFTER CONFERRING WITH THE HOMEOWNER.
- c. THE LOCATION OF THE BRANCHES SHALL BE MEASURED FROM THE LAST DOWNSTREAM MANHOLE AND AT LEAST THREE (3) TIES FROM AN EXISTING STRUCTURE, NORMALLY THE HOME IT IS TO SERVICE.
- d. NEAR SIDE SERVICES SHALL BE INSTALLED UP TO ONE (1) FOOT OF THE R.O.W. LINE.
- e. THE CONTRACTOR SHALL PROVIDE A 2" X 4" WOOD MARKER EXTENDED FROM THE WYE BRANCH TO ONE (1) FOOT BELOW GRADE.
- f. ON ALL SERVICES WHERE THE MAIN IS GREATER THAN 8' IN DEPTH, THE CONTRACTOR SHALL PROVIDE A RISER PIPE TO AN ELEVATION 8' BELOW EXISTING GRADE.

NOTES:

- 1. RECORDS OF THE DEPTH OF COVER SHALL BE KEPT FOR ALL HOUSE LATERALS BUILT ACROSS PAVEMENTS. SUCH RECORDS SHALL IDENTIFY THE LATERALS BY THE USE OF HOUSE NUMBERS AND SHALL SHOW LOCATION OF THE END OF THE HOUSE LATERAL WITH A MINIMUM OF THREE(3) TIES AS SHOWN IN EXAMPLE BELOW.
- 2. THE CONTRACTOR SHALL OBTAIN ALL HIGHWAY/R.O.W. PERMITS PRIOR TO START OF WORK.
- 3. VENTS AND CLEAN OUTS MUST BE INSTALLED IN LAWN AREAS, NOT IN SIDEWALK OR DRIVEWAY AREAS, PREFERABLY BETWEEN THE CURB OR EDGE OF PAVEMENT AND THE SIDEWALK.

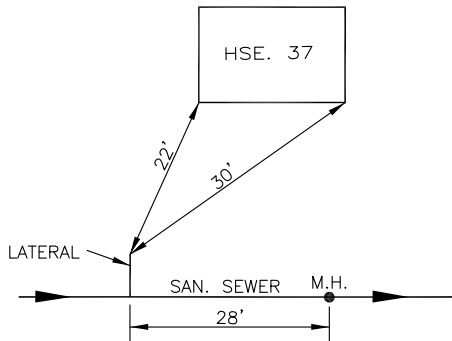

File: V:\DSM\Engineering\CAD\Details\Details November 2023\0-23.dwg, Last saved: 12/6/2023, Plot Date: 12/12/2023, Plot Style: DETAILS.CTB

**ERIE COUNTY**  
**DEPT. OF ENVIRONMENT & PLANNING**  
**DIVISION OF SEWERAGE MANAGEMENT**

<b>Rev. 1</b> 5/17/93	NOTE 2c: DEPTH 4'-0"
<b>Rev. 2</b> 12/9/96	CHANGED NOTE 1 TO THREE(3) TIES
<b>Rev. 3</b> 7/14/99	ADDED TITLE
<b>Rev. 4</b> 12/01	ADDED NOTE 3 REGARDING LOCATION OF VENTS AND CLEAN OUTS
<b>File:</b> D-23	<b>Date:</b> 3/1/91

**STD.DETAIL**  
  
**23**

# TYPICAL CROSS SECTION OF HIGHWAY CROSSING FOR HOUSE/ COMMERCIAL LATERALS (NOVEMBER 2023)

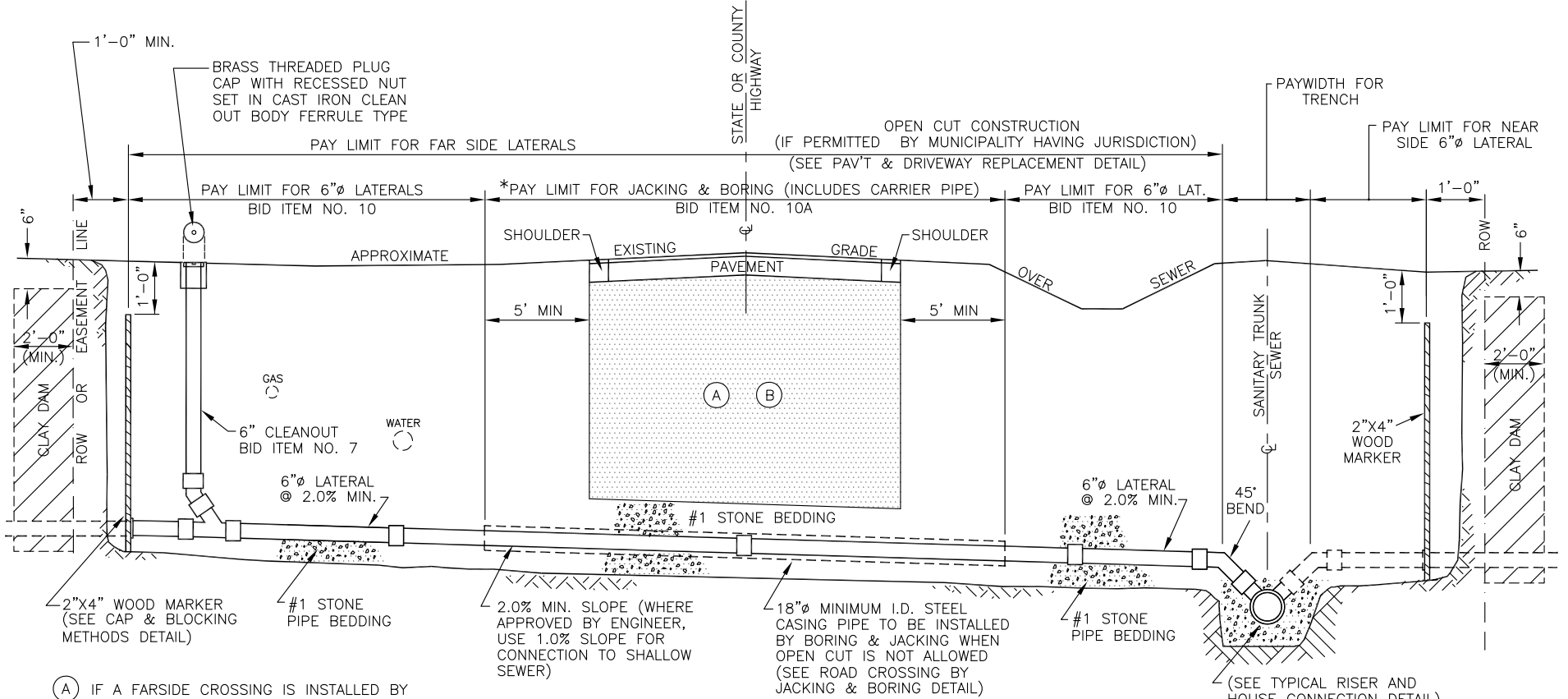

- (A) IF A FAR SIDE CROSSING IS INSTALLED BY OPEN CUT METHOD, FULL DEPTH SELECT FILL MATERIAL SHALL BE REQUIRED UNDER PAVEMENT & SHOULDER AREA AS DESCRIBED IN SECTION 01020- ITEM15 DESCRIPTION OF BID ITEMS-ECDEP SPECIFICATIONS.
- (B) NO. 2 RUN OF CRUSHER STONE WITH A GRADATION CONFORMING WITH NYSDOT SECTION 304-2.02 TYPE 4 AND NYSDOT SECTION 703-02 (LATEST EDITION ) COMPACTED IN 6" LIFTS TO 90% DENSITY.

NOTE:

- SHEETING, SHORING MATERIALS OR SHIELD SYSTEM NOT SHOWN.
- \* LENGTH OF PAY LIMIT FOR JACKING AND BORING VARIES IN ACCORDANCE WITH DIMENSIONS SHOWN ON THE PLAN SHEETS.
- \* CONCRETE ENCASEMENT IF COVER DEPTH IS LESS THAN 4'-0" UNDER PAVED AREAS (SEE TYP. CONCRETE ENCASEMENT DETAIL)

\* CLEAN OUTS MUST BE INSTALLED IN LAWN AREAS, NOT IN SIDEWALK OR DRIVEWAY AREAS UNLESS DIRECTED BY ENGINEER

**ERIE COUNTY**  
**DEPT. OF ENVIRONMENT & PLANNING**  
**DIVISION OF SEWERAGE MANAGEMENT**

REVISIONS	
6/9/92	ADDED CLAY DAM
3/19/93	OPEN CUT CLARIFICATION
2/7/94	ADDED CLAY DAM DIMENSIONS
7/14/99	CHANGED NOTES 1 & 2 TO A & B
12/01	1' SELECT FILL OVER PIPE
	ADDED NOTE ON LOCATION OF VENTS & C.O.
File:	D-24
Date:	3/1/91

**STD. DETAIL**  
  
**24**

File: V:\DSM\Engineering\CAD\Details\Details November 2023\0-24.dwg, Last saved: 12/6/2023, Plot Date: 12/12/2023, Plot Style: DETAILS.CTB



# ROAD CROSSING BY JACKING AND BORING METHOD 6" DIA. TO 24" DIA. CARRIER PIPE (NOVEMBER 2023)

TO PREVENT FLOATATION OR DISPLACEMENT AFTER THE CARRIER PIPE HAS BEEN PLACED AND TESTED, SPACE TO BE FILLED WITH NO. 1A PEA GRAVEL. (FLOWABLE FILL IS NOT PERMITTED)

PRESSURE TREATED WOOD SKIDS THICK ENOUGH TO ALLOW FOR CLEARANCE BETWEEN PIPE BELL OR COUPLING AND BOTTOM OF CASING PIPE OR A COMMERCIAL SYSTEM THAT UTILIZES STAINLESS STEEL BANDING AND NYLON SKIDS

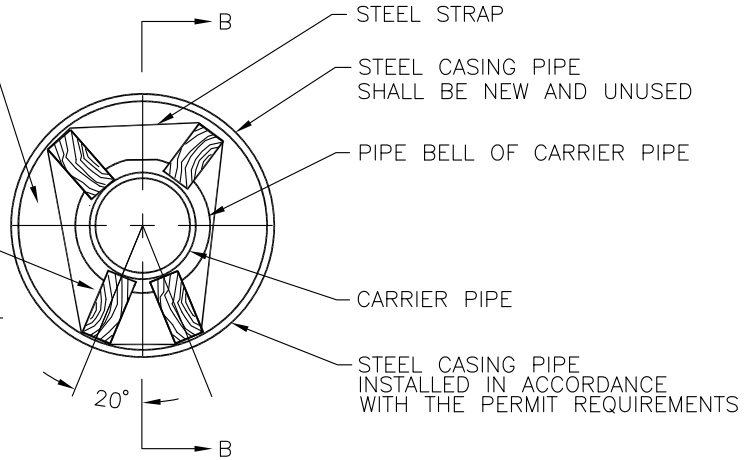

TEMPORARY SHEETING AS REQUIRED

BRICK & MORTAR BULKHEAD

SELECT MATERIAL BEDDING, AS SHOWN ON THE DRAWINGS

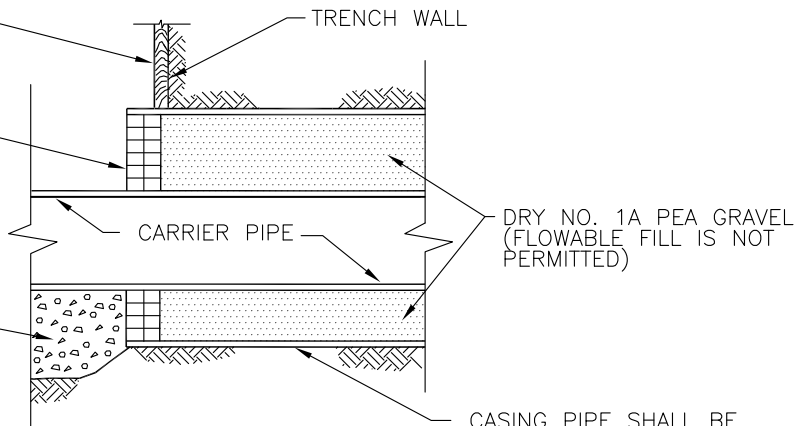

**SECTION B-B  
CASING PIPE DETAILS**

1. CASING PIPE GRADE SHALL BE AS SHOWN ON PLANS OR AS ORDERED BY ENGINEER.
2. MAXIMUM ALLOWABLE ERROR FOR THE CASING PIPE SHALL BE 0.2 OF A FOOT ABOVE OR BELOW THE DESIGN GRADE.
3. THE MAXIMUM ALLOWABLE ERROR ON THE HORIZONTAL ALIGNMENT OF THE CASING PIPE SHALL NOT EXCEED 4" OFF THE DESIGNED CENTERLINE OF IMPROVEMENT.
4. JACKING AND RECEIVING PIT, TEMPORARY SHEETING AND SHORING SHALL BE DESIGNED BY A N.Y.S. LICENSED ENGINEER RETAINED BY THE CONTRACTOR.
5. ANY ERROR IN GRADE AND/OR ALIGNMENT WHICH EXCEED THE NOTED ALLOWABLES SHALL BE CORRECTED AT THE CONTRACTOR'S EXPENSE.

**SCHEDULE FOR DIAMETER AND THICKNESS OF CASING PIPE**

CARRIER PIPE DIAMETER	CASING PIPE DIAMETER	CASING PIPE THICKNESS
6"	18"	0.375
8"	20"	0.375
10"	24"	0.375
12"	26"	0.375
15"	30"	0.375
18"	36"	0.500
21"	42"	0.500
24"	48"	0.500

**ERIE COUNTY  
DEPT. OF ENVIRONMENT & PLANNING  
DIVISION OF SEWERAGE MANAGEMENT**

Rev. 1 2/7/94	ADDED #1A PEA GRAVEL
Rev. 2 7/14/99	CHANGED THE SLOPE AND SIZE REQUIREMENTS FOR THE CASING PIPE
Rev. 3 12/01	ADDED 4 TH SKID AND ADDED ALT. CHOICE OF COMMERCIAL TYPE SKID
File:	D-25
Date:	3/1/91

**STD.DETAIL**

25

# CAP & BLOCKING METHODS FOR AIR TESTING

(NOVEMBER 2023)

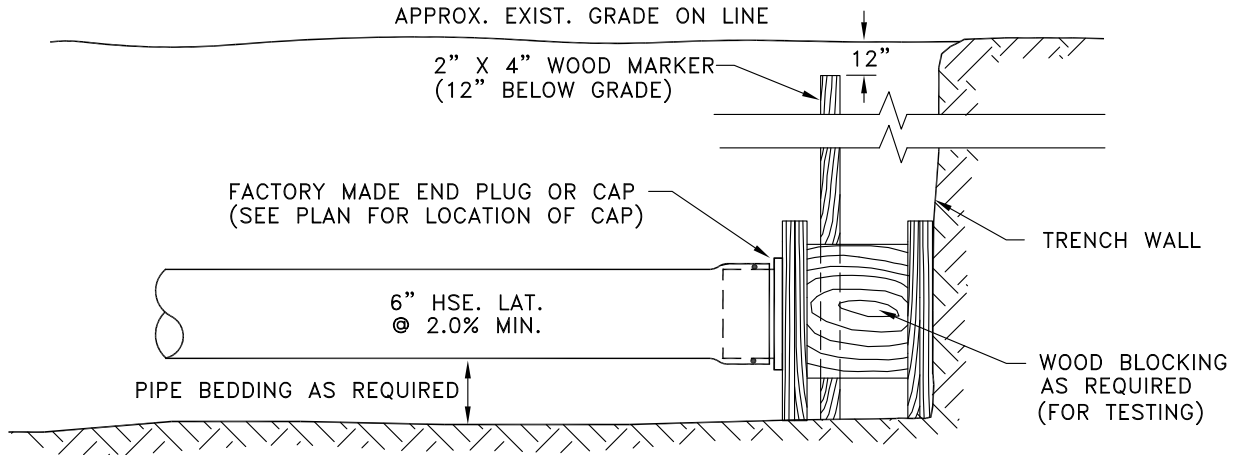

**TYPICAL SECTION**

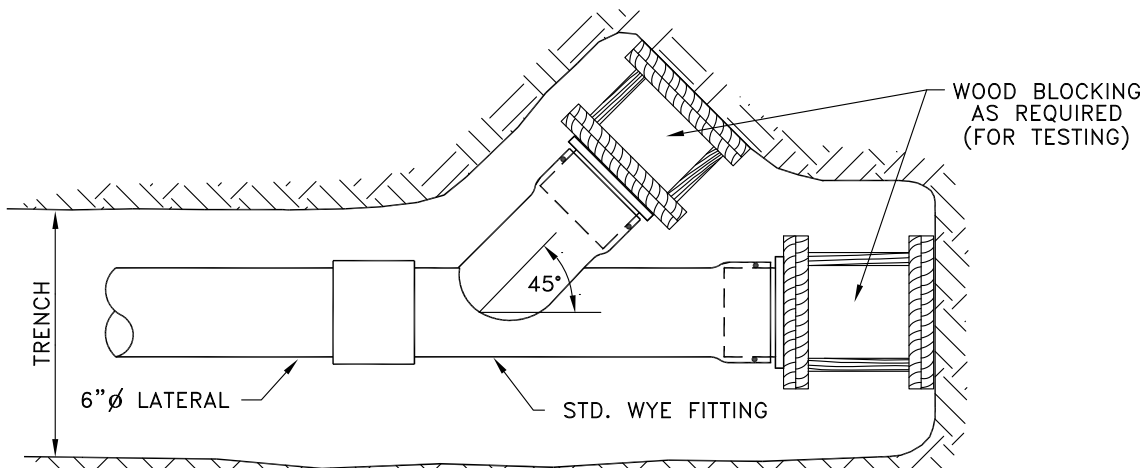

**TYPE "2" SERVICE LATERAL FITTING**

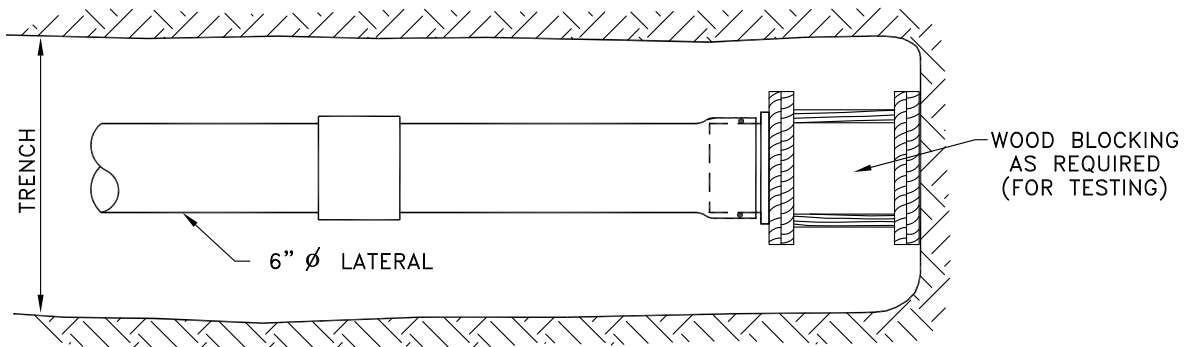

**TYPE "1" SERVICE LATERAL FITTING**

**ERIE COUNTY**  
**DEPT. OF ENVIRONMENT & PLANNING**  
**DIVISION OF SEWERAGE MANAGEMENT**

Rev. 1	
Rev. 2	
File: D-26	Date: 3/1/91

STD.DETAIL

26

# RISER DETAIL – SDR35 (MAIN LINE LATERAL CONNECTION) (NOVEMBER 2023)

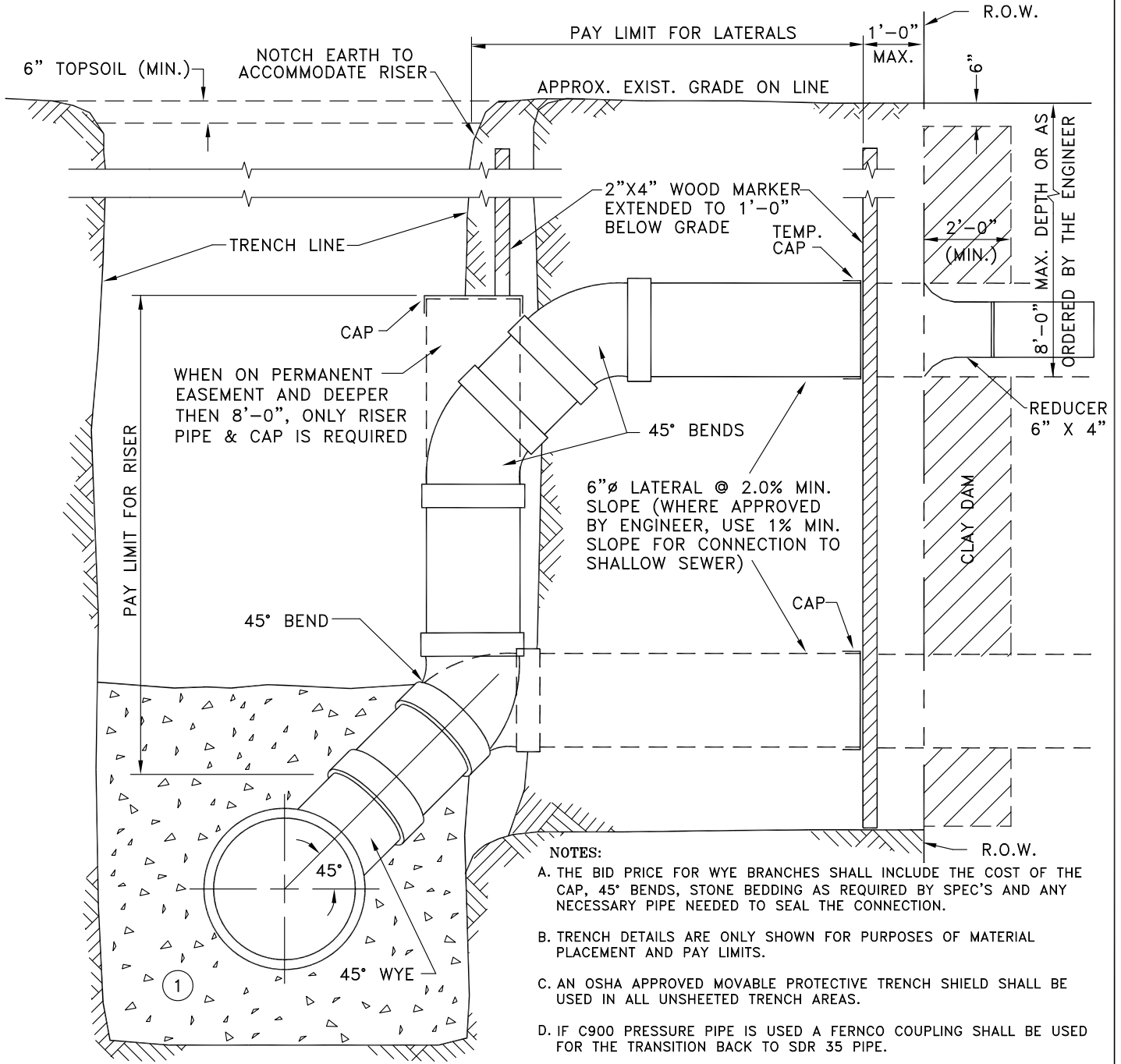

- NOTES:**
- A. THE BID PRICE FOR WYE BRANCHES SHALL INCLUDE THE COST OF THE CAP, 45° BENDS, STONE BEDDING AS REQUIRED BY SPEC'S AND ANY NECESSARY PIPE NEEDED TO SEAL THE CONNECTION.
  - B. TRENCH DETAILS ARE ONLY SHOWN FOR PURPOSES OF MATERIAL PLACEMENT AND PAY LIMITS.
  - C. AN OSHA APPROVED MOVABLE PROTECTIVE TRENCH SHIELD SHALL BE USED IN ALL UNSHEETED TRENCH AREAS.
  - D. IF C900 PRESSURE PIPE IS USED A FERNCO COUPLING SHALL BE USED FOR THE TRANSITION BACK TO SDR 35 PIPE.

**MATERIALS**

**PIPE BEDDING MATERIAL (NYS DOT LATEST EDITION)**

① NO. 1 CRUSHED STONE WITH A GRADATION CONFORMING WITH NYS DOT SECTION 703-02. THE CRUSHED STONE SHALL BE WELL GRADED WITH NO PARTICLES LARGER THAN ONE INCH AND HAVING A MAXIMUM GRADATION MEETING THE LIMITS DESCRIBED IN THE SPECIFICATIONS. THE BEDDING SHALL BE COMPACTED IN 6" LIFTS WITH EQUIPMENT ACCEPTABLE TO THE PIPE MANUFACTURER. NO SLAG WILL BE ALLOWED.

**ERIE COUNTY  
DEPT. OF ENVIRONMENT & PLANNING  
DIVISION OF SEWERAGE MANAGEMENT**

Rev. 2 1/97	ADDED 1/8 BELL & SPIGOT LONG SWEEP BEND
Rev. 3 12/01	ADDED NOTE D REGARDING LOCATION OF VENTS AND CLEAN OUTS
Rev. 4 5/02	CHANGED LONG SWEEP TO NORMAL 45° ADDED CAPS & CORRECTED PAY LIMITS
File:	D-27
Date:	3/1/91

**STD.DETAIL**

27

**RISER DETAIL - C-900**  
**(MAIN LINE LATERAL CONNECTION)**  
**(NOVEMBER 2023)**

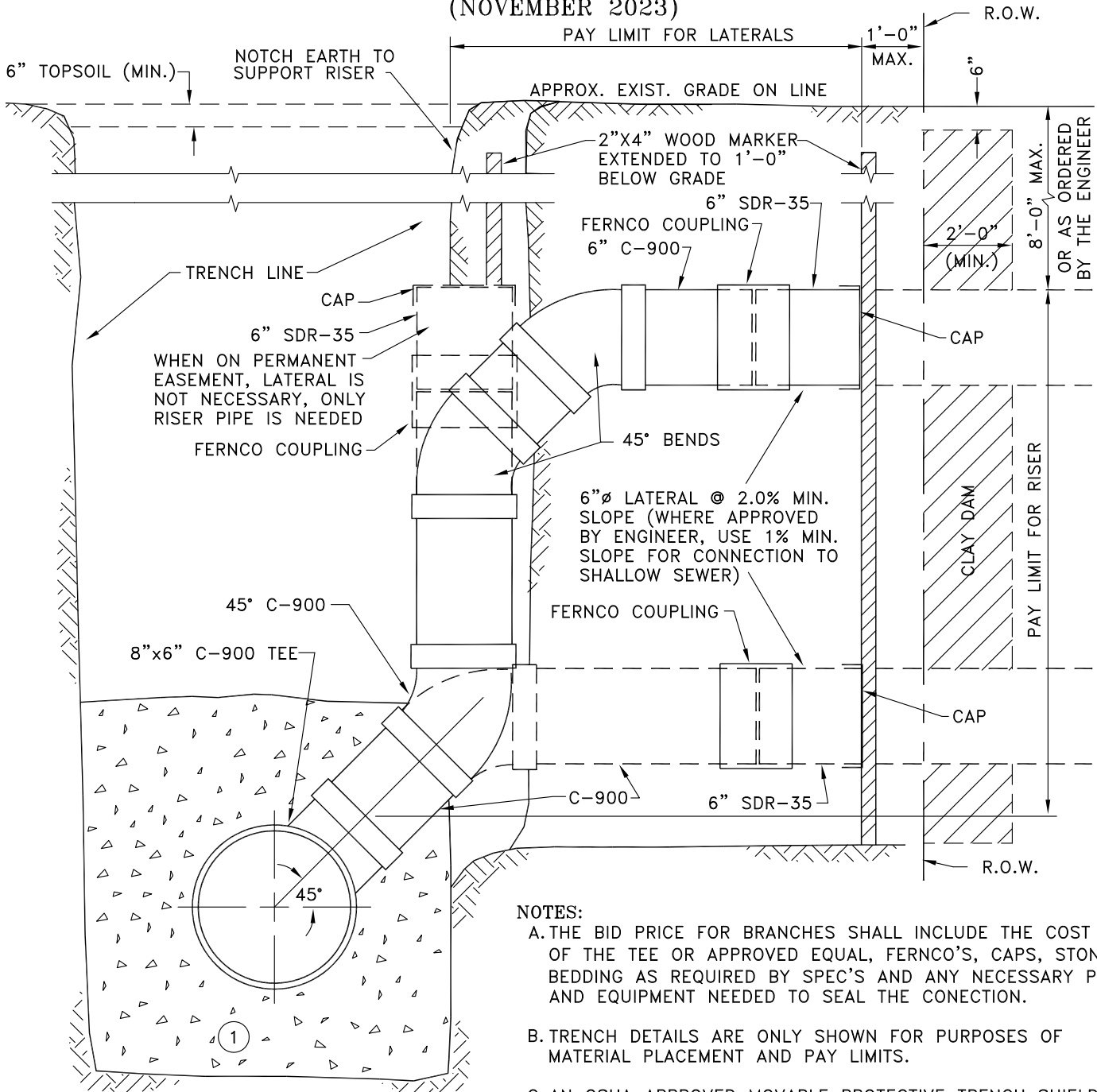

- NOTES:**
- A. THE BID PRICE FOR BRANCHES SHALL INCLUDE THE COST OF THE TEE OR APPROVED EQUAL, FERNCO'S, CAPS, STONE BEDDING AS REQUIRED BY SPEC'S AND ANY NECESSARY PIPE AND EQUIPMENT NEEDED TO SEAL THE CONNECTION.
  - B. TRENCH DETAILS ARE ONLY SHOWN FOR PURPOSES OF MATERIAL PLACEMENT AND PAY LIMITS.
  - C. AN OSHA APPROVED MOVABLE PROTECTIVE TRENCH SHIELD SHALL BE USED IN ALL UNSHEETED TRENCH AREAS.

**MATERIALS**  
**PIPE BEDDING MATERIAL (NYS DOT LATEST EDITION)**

① NO. 1 CRUSHED STONE WITH A GRADATION CONFORMING WITH NYS DOT SECTION 703-02. THE CRUSHED STONE SHALL BE WELL GRADED WITH NO PARTICLES LARGER THAN ONE INCH AND HAVING A MAXIMUM GRADATION MEETING THE LIMITS DESCRIBED IN THE SPECIFICATIONS. THE BEDDING SHALL BE COMPACTED IN 6" LIFTS WITH EQUIPMENT ACCEPTABLE TO THE PIPE MANUFACTURER. NO SLAG WILL BE ALLOWED.

**ERIE COUNTY**  
**DEPT. OF ENVIRONMENT & PLANNING**  
**DIVISION OF SEWERAGE MANAGEMENT**

Rev. 1	ADDED FERNCO COUPLINGS	STD.DETAIL
5/8/02		
Rev. 2		27a
File: D-27a	Date: 9/20/99	

File: V:\DSM\Engineering\CAD\Details\Details November 2023\10-27a.dwg, Last saved: 12/16/2023, Plot Date: 12/12/2023, Plot Style: DETAILS.CTB

# CLEAN-OUT DETAIL FOR SERVICE CONNECTION (NOVEMBER 2023)

**NOTES:**

1. ALL PAVEMENT CROSSINGS (OPEN CUT METHOD) WITH LESS THAN 4'-0" COVER SHALL BE ENCASED WITH 2000 PSI CONCRETE.
2. CLEAN-OUTS ARE REQUIRED AS SHOWN ON PLANS.

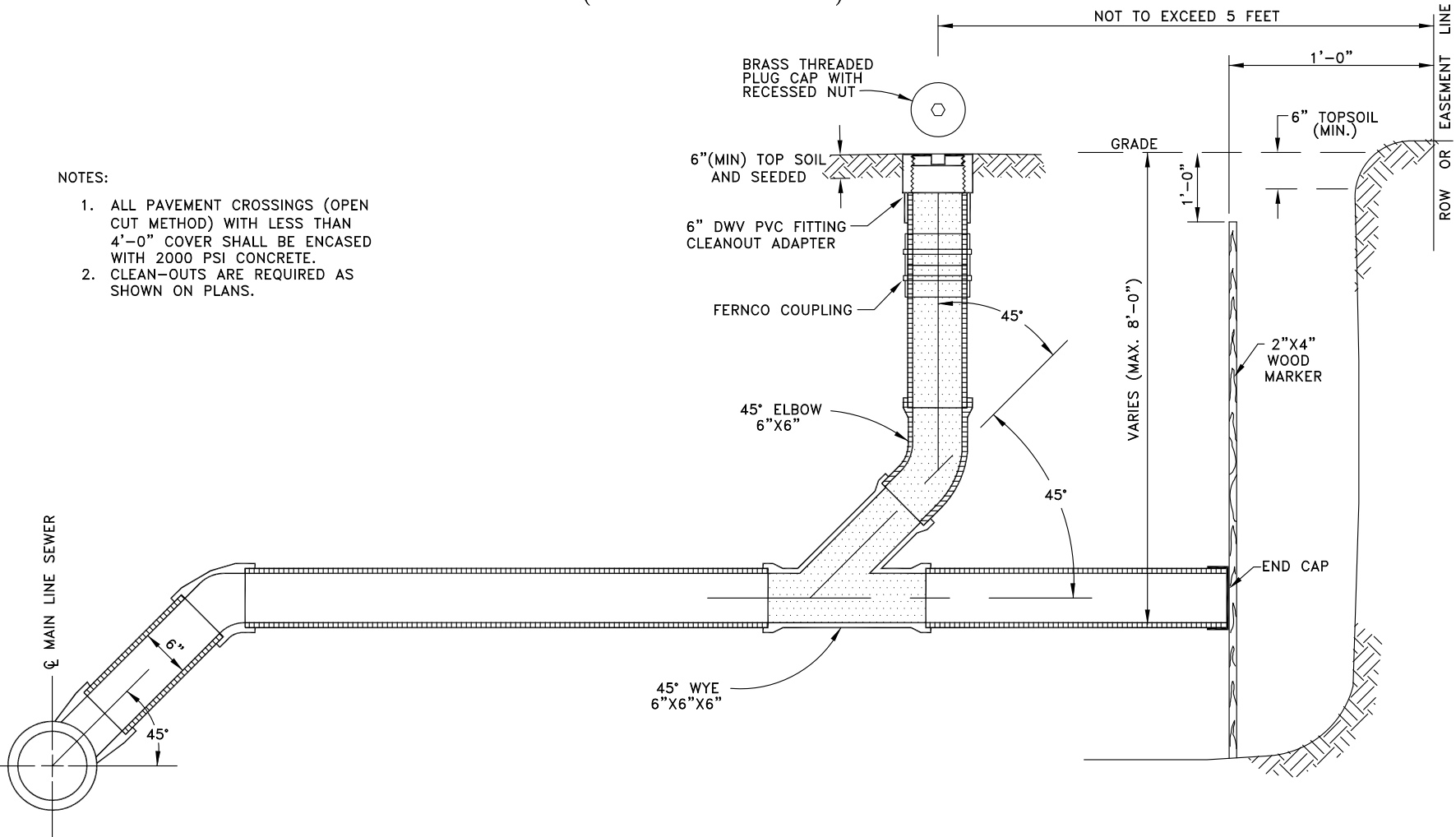

**ERIE COUNTY**  
**DEPT. OF ENVIRONMENT & PLANNING**  
**DIVISION OF SEWERAGE MANAGEMENT**

Rev. 1	2/94	CHANGED DIM LINE FOR MAX. DEPTH
Rev. 2	12/01	ADDED NOTE 7
Rev. 3	5/02	CHANGED C.I. CAP TO BRASS
Rev. 4	6/05	1' MIN. FROM EDGE OF WALK NOTE
Rev. 5	1/12	CHANGED C.I. TO BRASS NOTES 1 & 3
Rev. 5	3/24	REVISED NOTES & REMOVED CAST IRON

File: D-28 Date: 3/1/91

STD. DETAIL

28

# SEDIMENT TRAP / GREASE TRAP DETAIL (NOVEMBER 2023)

NOTES

- 1) THE UNITS SHALL BE REINFORCED TO WITHSTAND H-20 LOADING
- 2) A GREASE TRAP IS REQUIRED ON ALL DISCHARGES FROM A RESTAURANT OR OTHER TYPES OF COMMERCIAL BUILDINGS WHEN FOOD IS SERVED.
- 3) TANK SIZE FOR:
  - A) RESTAURANTS SHALL BE 7.5 TIMES NUMBER OF MEALS PREPARED IN ONE DAY.
  - B) HOSPITAL AND NURSING HOMES SHALL BE 22 TIMES NUMBER OF BEDS.
 THE MINIMUM SIZE GREASE TRAP SHALL BE 750 GALLONS.
- 4) FOR GAS STATIONS AND FACILITIES WITH FLOOR DRAINS TIED INTO THE SANITARY SEWER, BEFORE THE GREASE TRAP, A SEDIMENTATION TANK (2'X2' OR 3'X3' D.I.) WITH 24" SUMP AND GRATE SHALL BE REQUIRED. THE SEDIMENT TANK SHALL BE AS CLOSE AS POSSIBLE TO THE DISCHARGE POINT OF THE FLOOR DRAIN.
- 5) GREASE TRAP SHALL CONFORM TO 19 NYCRR PART 1229.

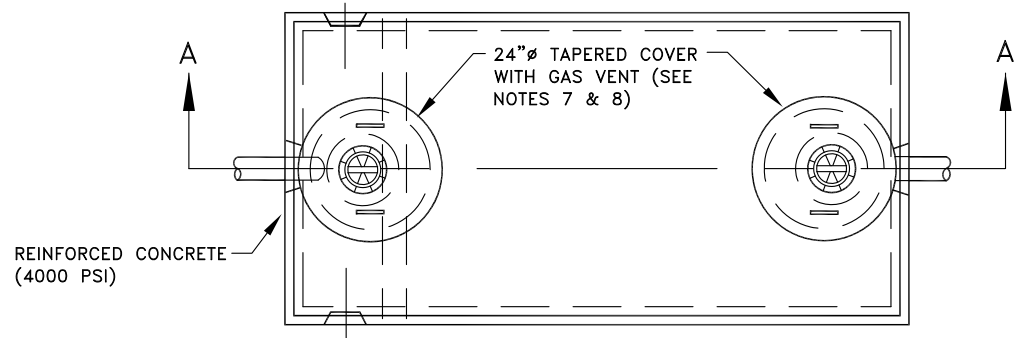

**GREASE TRAP  
TOP VIEW**

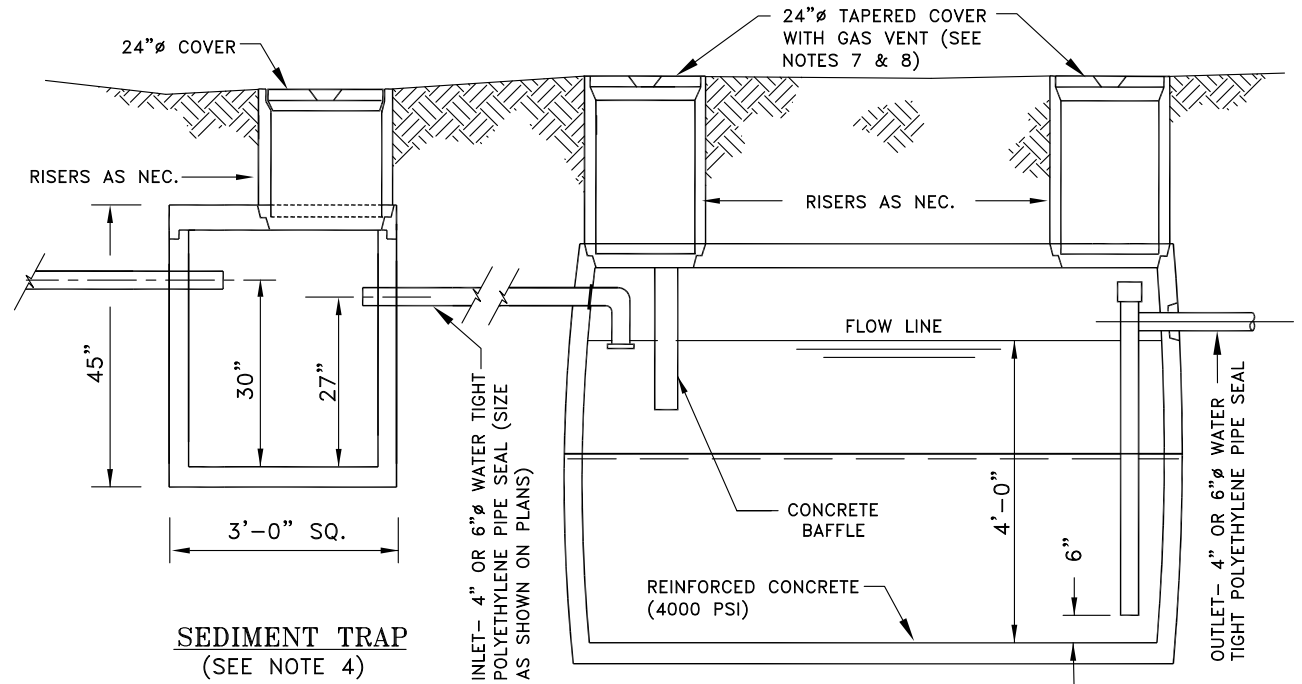

**SEDIMENT TRAP  
(SEE NOTE 4)**

**GREASE TRAP  
SECTION A-A**

**ERIE COUNTY**  
**DEPT. OF ENVIRONMENT & PLANNING**  
**DIVISION OF SEWERAGE MANAGEMENT**

Rev. 1	8/23/91	CHANGED INLET AND OUTLET DIA TO 6"
Rev. 2	12/9/96	MODIFIED NOTES 2 & 3
Rev. 3	12/01	ADDED GRIT TRAP BEFORE GREASE TRAP, NOTES 4 & 5
Rev. 4	5/03	REMOVED NOTE 5.
Rev. 5	6/05	ADDED TO NOTE 4
Rev. 6	3/31/22	ADDED PART 1229

STD. DETAIL

29

File: D-29      Date: 3/1/91

# SIMPLEX OR DUPLEX LOW PRESSURE GRINDER PUMP (NOVEMBER 2023)

INTERMEDIATE ACCESS COVER WITH RECESSED ACCESS HANDLE SHALL BE OF SUFFICIENT SIZE TO ALLOW FOR PULLING OF PUMP, CLOSING GATE VALVE & OPERATING BYPASS TEE

HASP & LOCK  
(LOCK SHALL BE KEYED TO DISTRICT'S MASTER SYSTEM)

2" MUSHROOM VENT

FLASHING ALARM LIGHT

PANEL MOUNTING STAND  
(OPTIONAL METHOD TO USE MOUNTED PANEL)

EMERGENCY GENERATOR RECEPTACLE

INCOMING POWER FROM BLDG. RIGID CONDUIT PAST DISTURBED AREA, THEN TRANSITION TO PVC

INFLUENT HUB SHALL BE LOCATED IN THE FIELD AND INSTALLED IN THE FIELD

POLYETHYLENE OR FIBERGLASS WETWELL (36" DIA.)

PUMP OFF LEVEL

FILLET

NO.1 CRUSHED STONE

A

BYPASS PUMP TEE

STATIONARY SUMP COVER

4 - 5/8"X1"LG. HOLD DOWN BOLT SLOTS

A

ELECTRICAL CONDUIT TO REMOTE CONTROL PANEL LOCATED AT HOUSE OR NEAR THE GRINDER AS SHOWN IN SECTION A-A

SIMPLEX OR DUPLEX CONTROL PANEL (NEMA 4X)

2" MUSHROOM VENT

5/8" X 1" STAINLESS STEEL BOLTS

EXCAVATED AREA

BALL VALVE EXTENSION STEM

BYPASS TEE

1-1/4" NPT BALL VALVE

1-1/4" NPT DISCHARGE

LIFTING CHAIN

1-1/4" x 1/2" TEE

1/2" ANTI-SIPHON VALVE

TO STREET SEWER  
(ELEV. BELOW FROST LINE - 48" MIN.)

HYDRAULICALLY SEALED DISCHARGE FLANGE

CHECK VALVE

ALARM LEVEL

PUMP ON LEVEL

E-ONE OR EQUAL

MINIMUM 1.5 CUBIC YARDS OF 3000 PSI CONCRETE FOR ANTI-FLOTATION

6" (MIN.)

SECTION A-A

File: V:\DSM\Engineering\CAD\Details\November 2023\D-30.dwg, Last saved: 12/7/2023, Plot Date: 12/12/2023, Plot Style: DETAILS.CTB

**ERIE COUNTY**  
**DEPT. OF ENVIRONMENT & PLANNING**  
**DIVISION OF SEWERAGE MANAGEMENT**

Rev. 1	ADDED EXCAVATED AREA, RECESSED ACCESS HANDLE, EMERGENCY GENERATOR RECEPTACLE, RIGID CONDUIT TO PVC, MOUNT JUNCTION BOX TO PANEL, & PANEL HEIGHT NOTES
6/05	
Rev. 2	ADDED "DUPLEX" TO TITLE DELETED JUNCTION BOX / MERCURY FLOAT-SWITCH
7/10	

STD.DETAIL

30

File: D-30

Date: 3/1/91

# TYPICAL HOUSE ELECTRIC SERVICE CONNECTION

(NOVEMBER 2023)

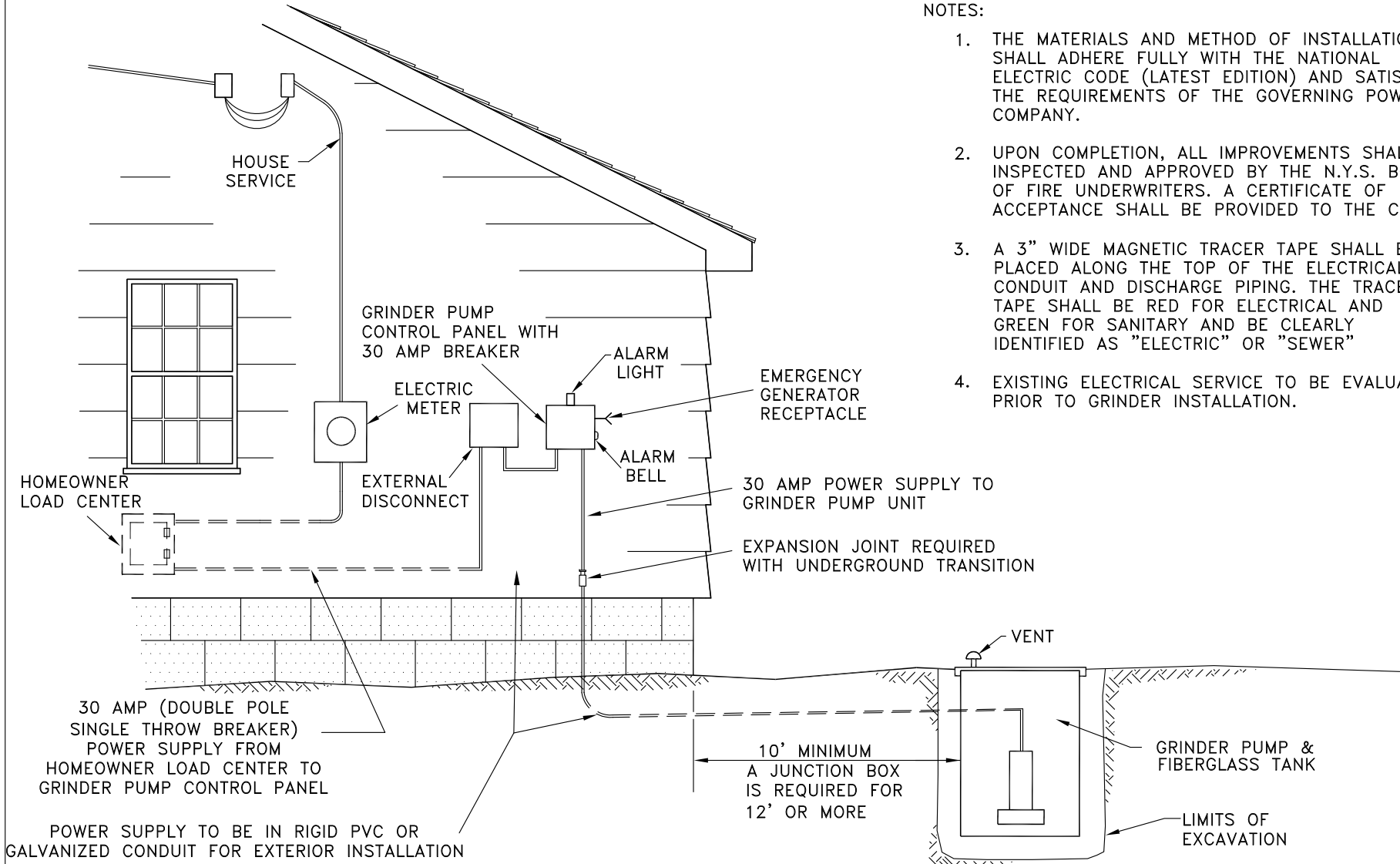

**NOTES:**

1. THE MATERIALS AND METHOD OF INSTALLATION SHALL ADHERE FULLY WITH THE NATIONAL ELECTRIC CODE (LATEST EDITION) AND SATISFY THE REQUIREMENTS OF THE GOVERNING POWER COMPANY.
2. UPON COMPLETION, ALL IMPROVEMENTS SHALL BE INSPECTED AND APPROVED BY THE N.Y.S. BOARD OF FIRE UNDERWRITERS. A CERTIFICATE OF ACCEPTANCE SHALL BE PROVIDED TO THE COUNTY.
3. A 3" WIDE MAGNETIC TRACER TAPE SHALL BE PLACED ALONG THE TOP OF THE ELECTRICAL CONDUIT AND DISCHARGE PIPING. THE TRACER TAPE SHALL BE RED FOR ELECTRICAL AND GREEN FOR SANITARY AND BE CLEARLY IDENTIFIED AS "ELECTRIC" OR "SEWER"
4. EXISTING ELECTRICAL SERVICE TO BE EVALUATED PRIOR TO GRINDER INSTALLATION.

File: V:\DSM\Engineering\CAD\Details\Details November 2023\D-31.dwg, Last saved: 12/19/2023, Plot Date: 12/19/2023, Plot Style: DETAILS.CTB

**ERIE COUNTY**  
**DEPT. OF ENVIRONMENT & PLANNING**  
**DIVISION OF SEWERAGE MANAGEMENT**

Rev. 1	11/23 Added External Disconnect
Rev. 2	
File:	D-31
Date:	3/1/91

STD. DETAIL  
  
**31**



# TYPICAL FORCE MAIN SERVICE CONNECTION

(NOVEMBER 2023)

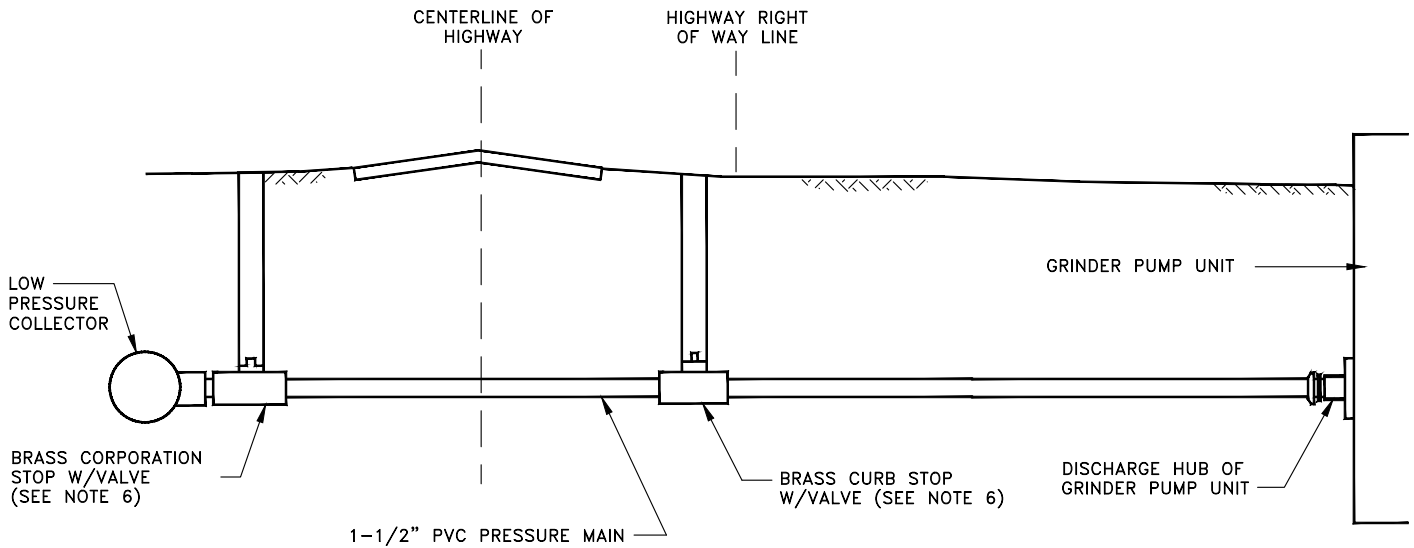

**NOTES:**

1. SERVICE CONNECTION SHALL HAVE A MINIMUM OF 4.0' OF COVER.
2. ROAD CROSSING SHALL BE JACKED OR BORED UNLESS OTHERWISE SHOWN OR SPECIFIED.
3. CORPORATION STOP TO BE SET IN TAPPED TEE OR TAPPED COUPLING.
4. ALL NECESSARY FITTINGS SHALL BE BRASS
5. A 3" WIDE MAGNETIC DETECTABLE TAPE SHALL BE INSTALLED ONE (1) FOOT ABOVE THE PRESSURE TUBING.
6. CURB BOXES MUST BE INSTALLED IN LAWN AREAS, NOT IN SIDEWALK OR DRIVEWAY AREAS, PREFERABLY BETWEEN THE CURB OR EDGE OF PAVEMENT AND THE SIDEWALK.

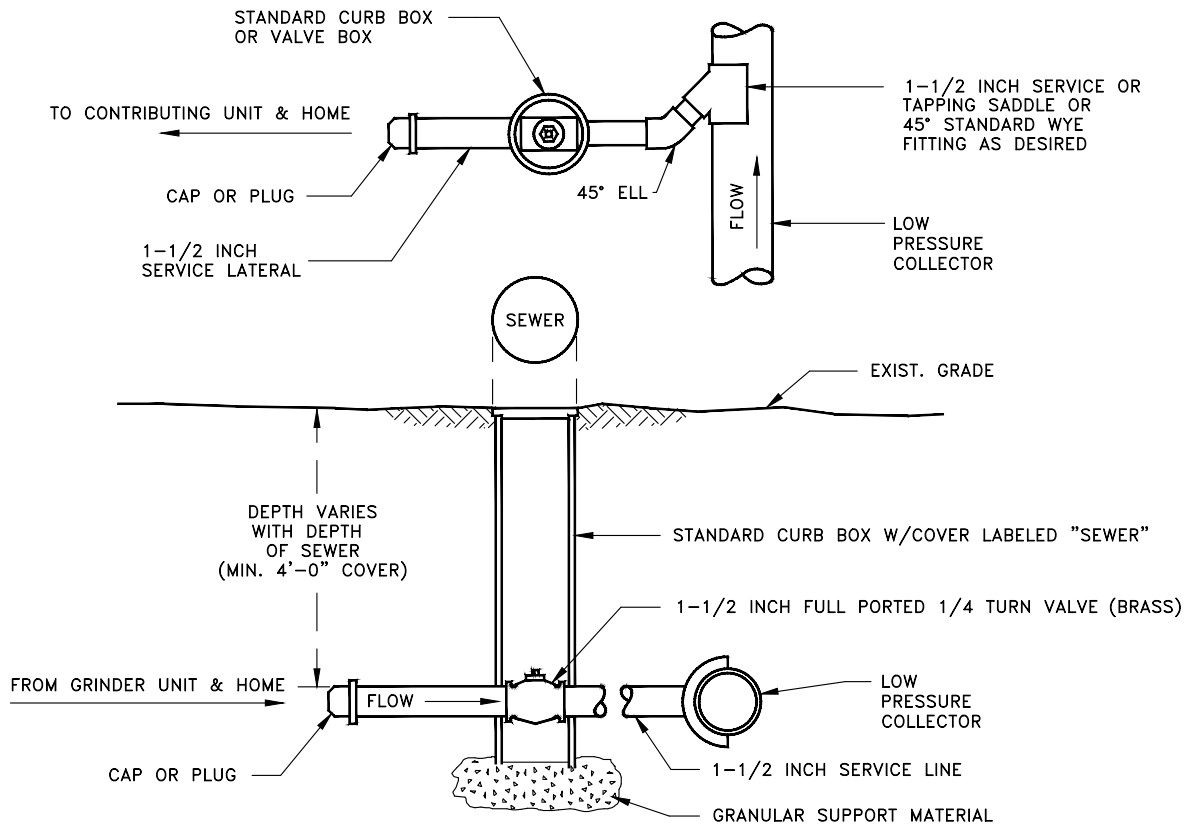

ERIE COUNTY  
DEPT. OF ENVIRONMENT & PLANNING  
DIVISION OF SEWERAGE MANAGEMENT

Rev. 1	ADDED NOTE 6 REGARDING LOCATION OF CURB BOXES
12/01	
Rev. 2	LABELED LOW PRESSURE COLLECTOR
6/05	
File:	D-32
Date:	3/1/91

STD.DETAIL

32

# GRINDER PUMP FORCE MAIN CONNECTION TO GRAVITY SEWER LINE DETAIL (NOVEMBER 2023)

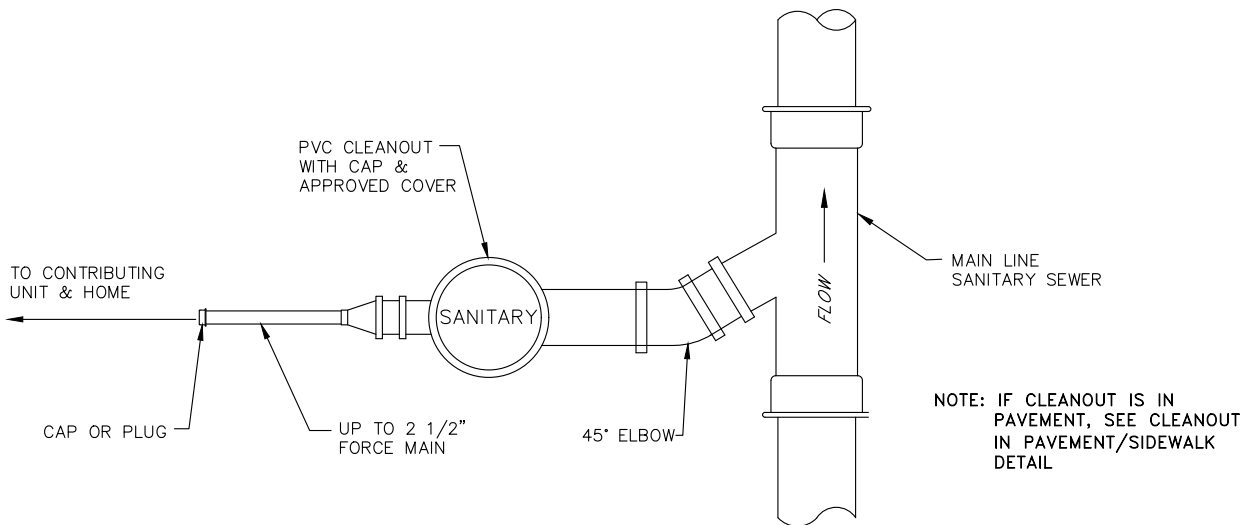
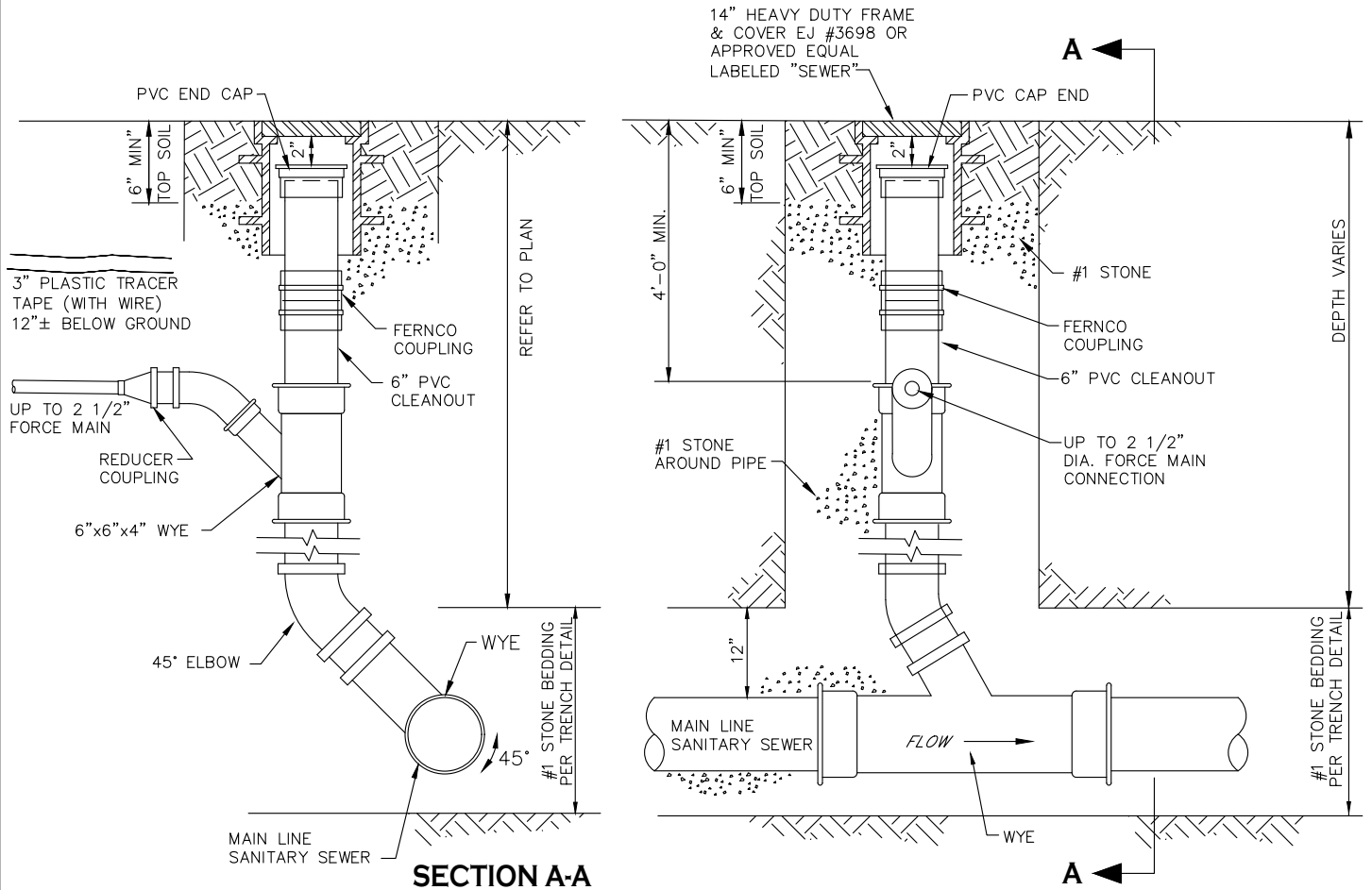

File: v:\DSM\Engineering\CAD\Details\Details November 2023\D-32a.dwg, Last saved: 12/14/2023, Plot Date: 5/21/2024, Plot Style: DETAILS.CTB

**ERIE COUNTY**  
DEPT. OF ENVIRONMENT & PLANNING  
DIVISION OF SEWERAGE MANAGEMENT

Rev. 1	Added Fernco Coupling	STD.DETAIL
11/23		
Rev. 2		
File:	D-32a	Date: 6/29/05

32a

# SANITARY SEWER PIPE & MANHOLE ABANDONMENT

(NOVEMBER 2023)

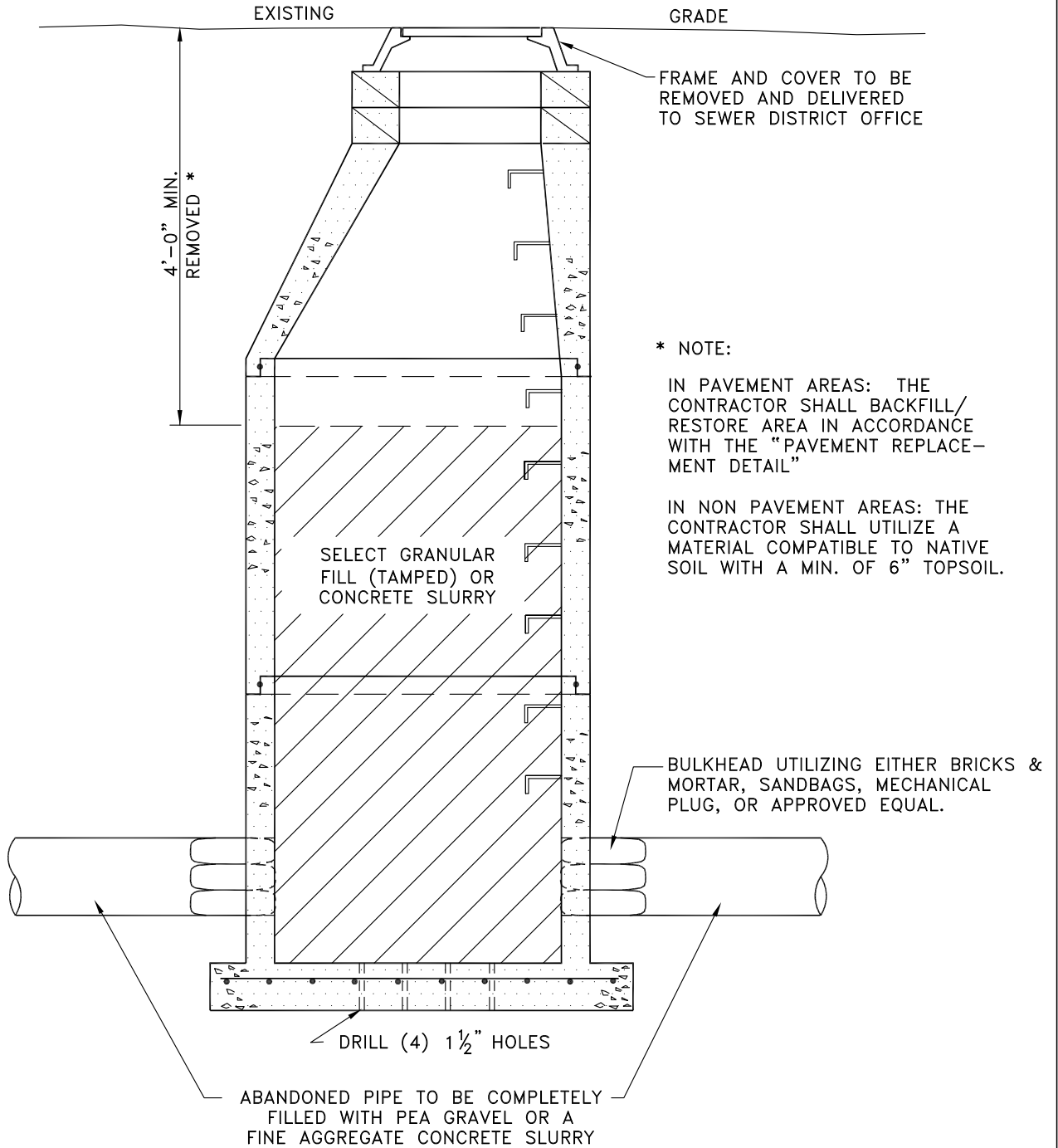

File: V:\DSM\Engineering\CAD\Details\Details November 2023\0--33.dwg, Last saved: 12/7/2023, Plot Date: 12/12/2023, Plot Style: DETAILS.CTB

**ERIE COUNTY**  
**DEPT. OF ENVIRONMENT & PLANNING**  
**DIVISION OF SEWERAGE MANAGEMENT**

Rev. 1 2/7/94	ADDED TAMPED TO SELECT GRANULAR FILL
Rev. 2 11/13/23	REMOVED NYSDOT ITEM 203.07 AND ADDED CONCRETE SLURRY
File: D-33	Date: 7/18/91

STD.DETAIL

33

# TYPICAL HOUSE CONNECTION/ABANDONMENT DETAIL

(NOVEMBER 2023)

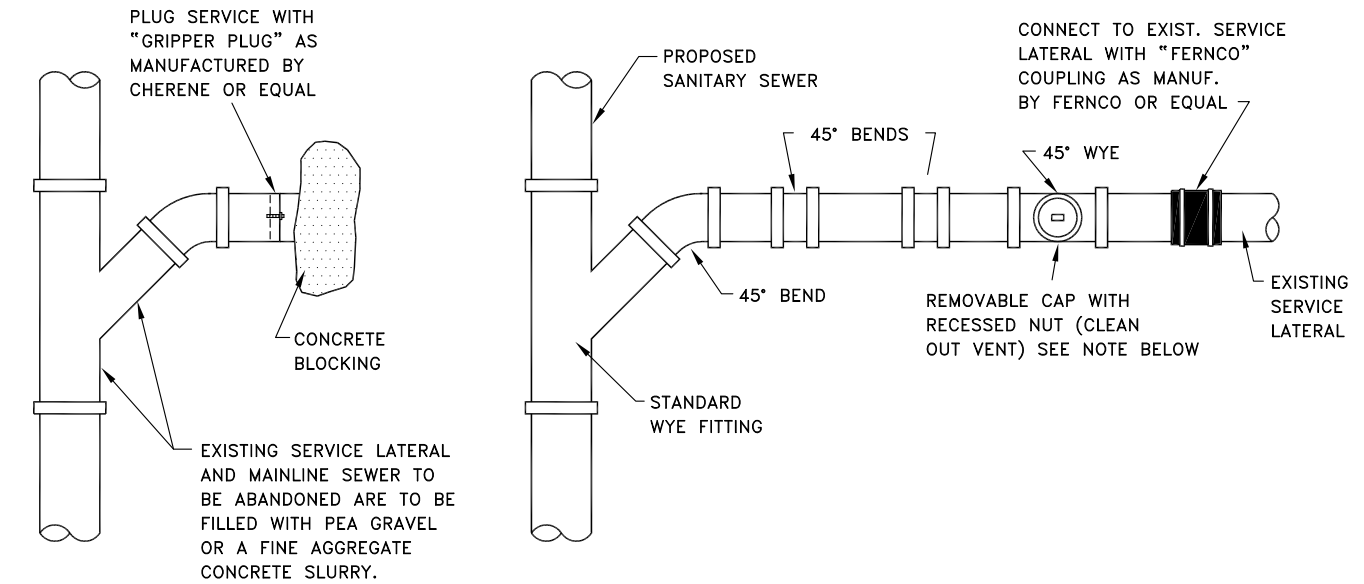

PLAN VIEW

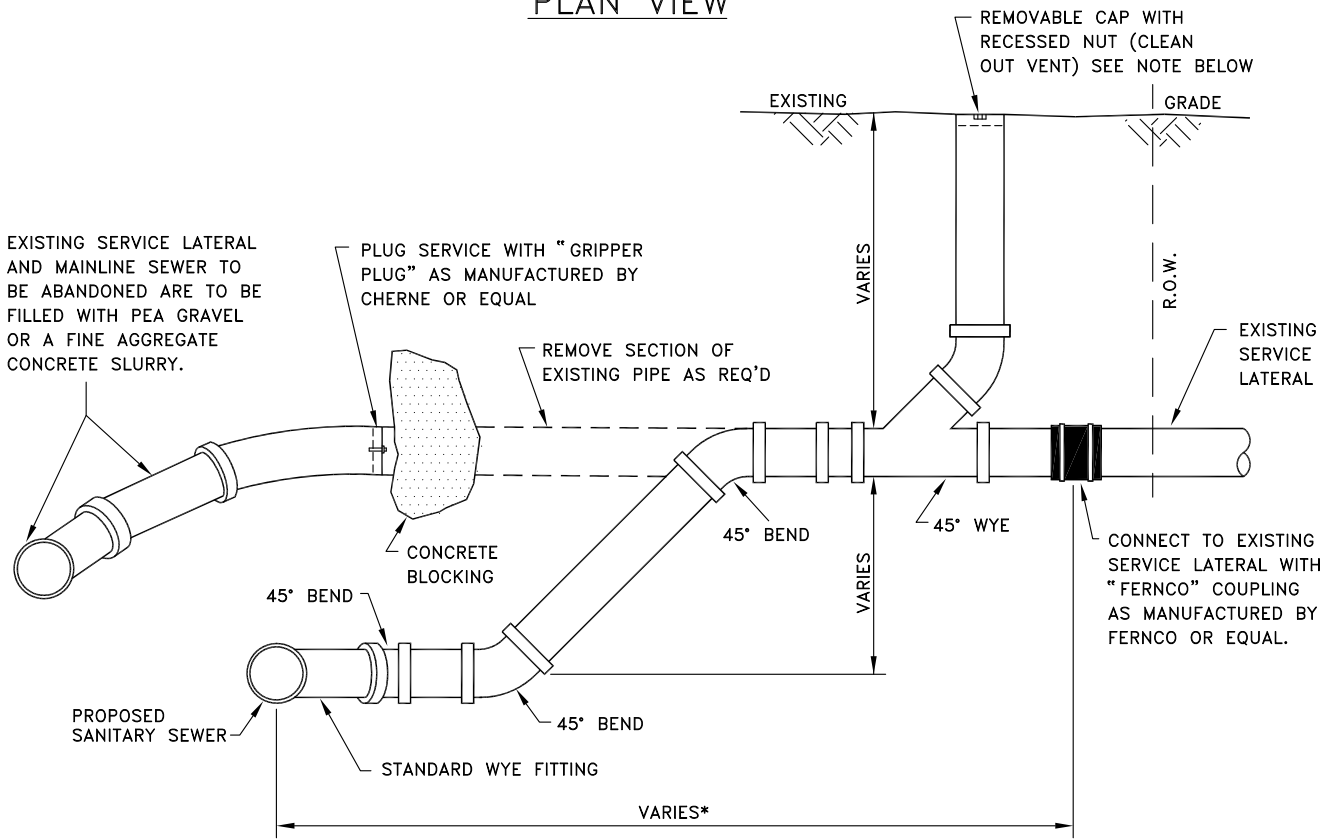

PROFILE VIEW

**\*NOTES:**

- 1.) THE CONTRACTOR SHALL CONNECT TO THE FIRST GOOD STRUCTURALLY SOUND SECTION OF PIPE ON THE EXISTING SERVICE LATERAL AS DETERMINED IN THE FIELD DURING CONSTRUCTION.
- 2.) VENTS AND CLEAN OUTS MUST BE INSTALLED IN LAWN AREAS, NOT IN SIDEWALK OR DRIVEWAY AREAS, PREFERABLY BETWEEN THE CURB OR EDGE OF PAVEMENT AND THE SIDEWALK.

**ERIE COUNTY**  
**DEPT. OF ENVIRONMENT & PLANNING**  
**DIVISION OF SEWERAGE MANAGEMENT**

Rev. 1	ADDED *NOTE, LATERAL CONNECTION	<b>STD.DETAIL</b>
12/9/96		
Rev. 2	ADDED NOTE 2 IN REGARDS TO LOCATION OF VENTS & C.O.	
12/18/00		
File: D-34	Date: 7/19/91	

# PRECAST DOGHOUSE BASE MANHOLE

(NOVEMBER 2023)

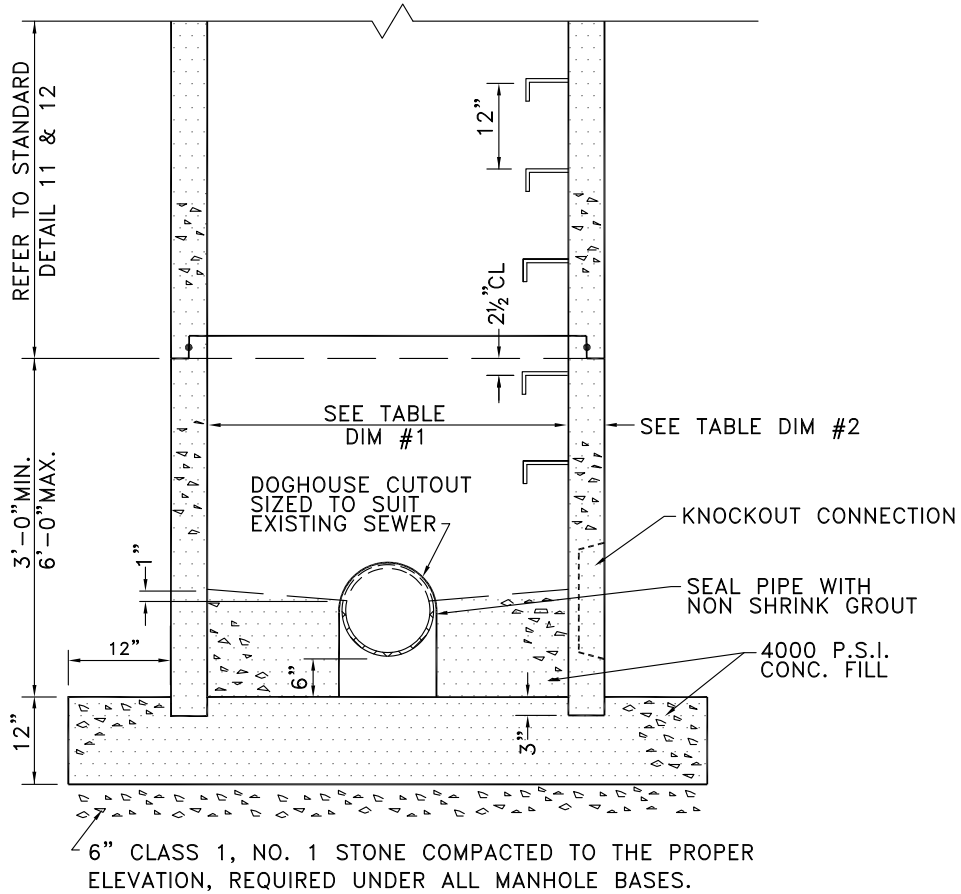

PIPE SIZE	DIMENSION #1	DIMENSION #2
8"-16"	4'-0"*	5"
18"	5'-0"	6"
21"-27"	5'-0"	6"
30"-36"	6'-0"	7"

\* FOR DROP CONNECTIONS INSIDE DIAMETER SHALL BE 5'-0"

**NOTE:**

AREA AROUND DOGHOUSE CUTOUT & PIPE TO BE MADE WATERTIGHT UTILIZING A HYDRAULIC CEMENT MIXTURE (WATERPLUG, PRECO-PATCH, OR APPROVED EQUAL).

<b>Rev. 1</b> 11/08/91	ADDED PIPE SIZE CHART & NOTE
<b>Rev. 2</b> 2/7/94	REVISED STONE UNDER MANHOLE BASE TO CLASS 1, NO. 1
<b>File:</b> D-35	<b>Date:</b> 10/16/91

# TYPICAL FORCEMAIN MANHOLE (NOVEMBER 2023)

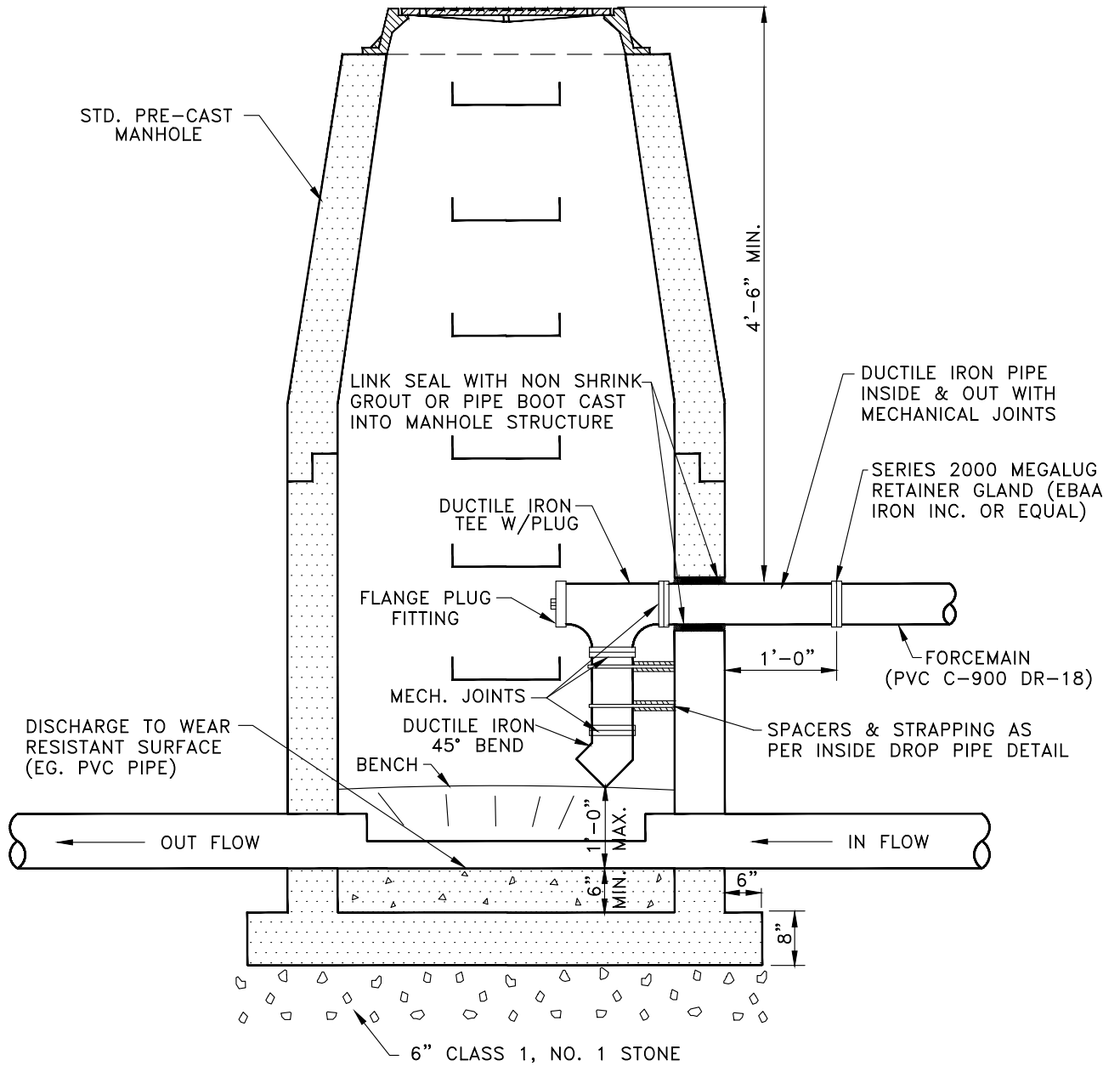

File: V:\DSM\Engineering\CAD\Details\November 2023\D-36.dwg, Last saved: 12/12/2023, Plot Date: 5/21/2024, Plot Style: DETAILS.CTB

**ERIE COUNTY**  
**DEPT. OF ENVIRONMENT & PLANNING**  
**DIVISION OF SEWERAGE MANAGEMENT**

Rev. 1 2/7/94	ADDED NON-SHRINK GROUT NOTE, CHANGED STONE TO CLASS 1, NO. 1
Rev. 2 12/01	REVISED NON-SHRINK GROUT NOTE, TO INCLUDE LINK SEAL AND PIPE BOOT
File: D-36	Date: 4/15/93

**STD.DETAIL**  
36

# CONNECTION TO EXISTING MANHOLE

(NOVEMBER 2023)

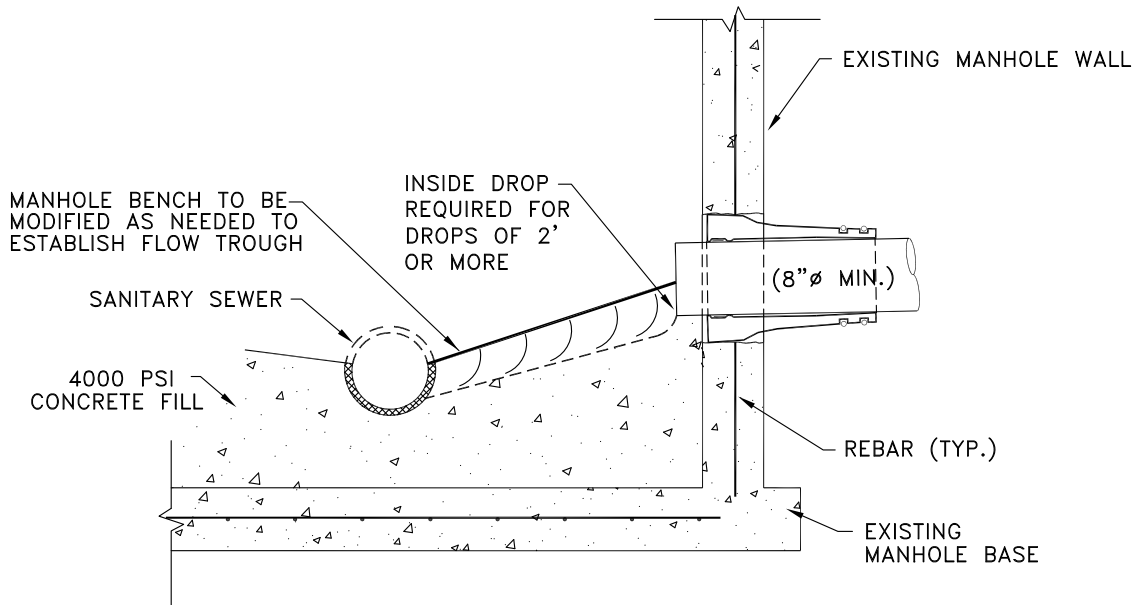

**NOTES:**

1. CORE DRILL ENTRANCE HOLE IN PRECAST MANHOLE BARREL, BASE AND/OR BENCH FOR REQUIRED PIPE CLEARANCE. PER MANUFACTURERS RECOMMENDATIONS.
2. DOES NOT APPLY TO HOUSE LATERALS.
3. WATERTIGHT PIPE TO MANHOLE BOOT SEAL REQUIRED FOR ALL CORE DRILLED ENTRANCE HOLES IN MANHOLE BARREL AS SHOWN BELOW.

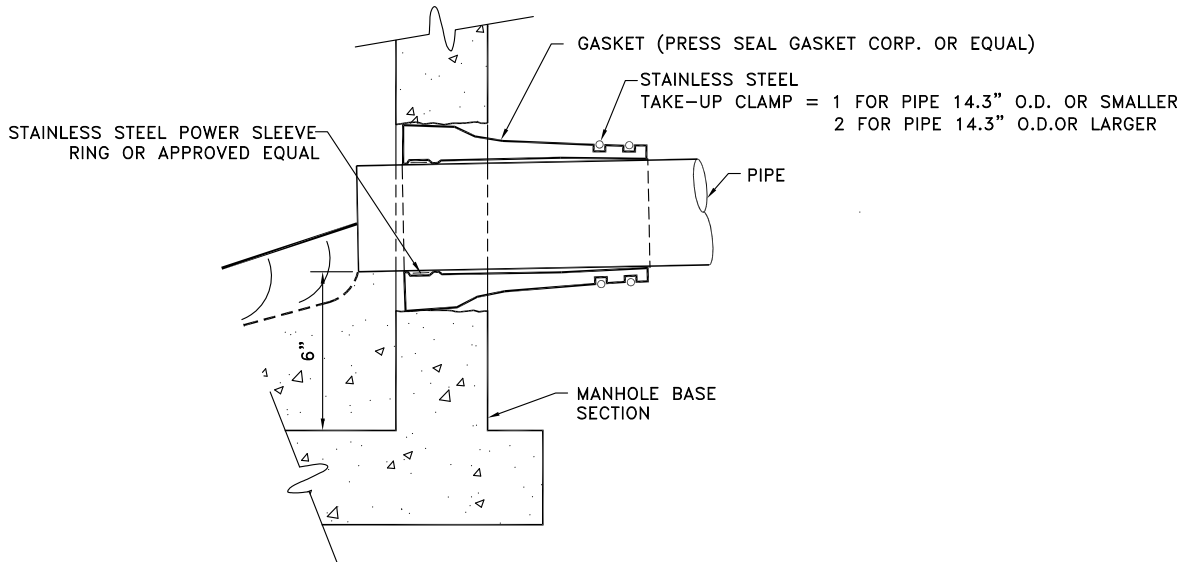

**ERIE COUNTY**  
**DEPT. OF ENVIRONMENT & PLANNING**  
**DIVISION OF SEWERAGE MANAGEMENT**

Rev. 1	ADDED MH BOOT SEAL DETAIL AND NOTE.
12/9/96	
Rev. 2	
File: D-37	Date: 4/15/93

STD.DETAIL

37

# PUMP STATION "A"

(NOVEMBER 2023)

**NOTE:** RIGHT HAND LAYOUT SHOWN, LEFT HAND LAYOUT ACCEPTABLE.  
ALTERNATIVE SITE LAYOUTS MAY BE SUBMITTED FOR APPROVAL.

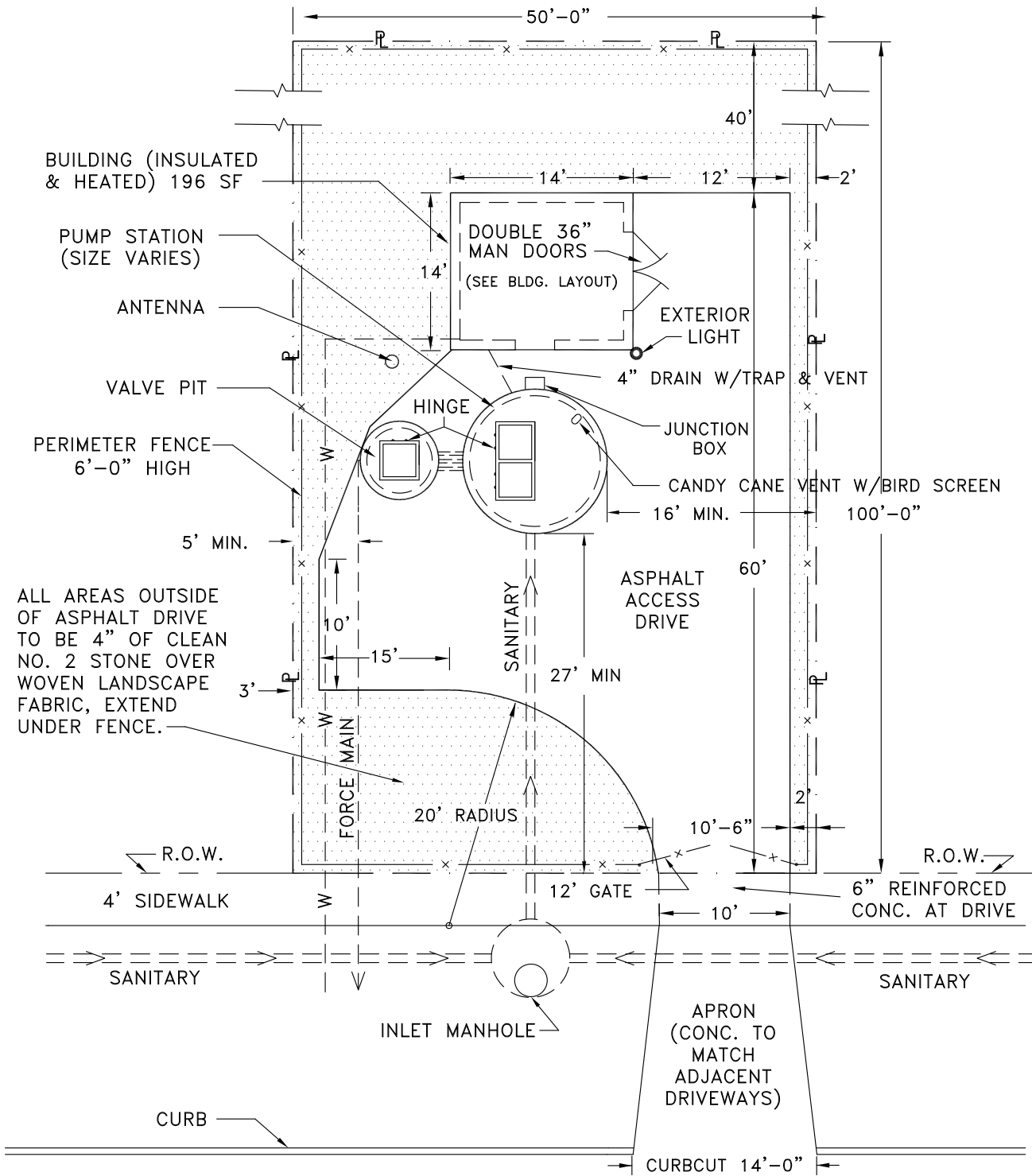

ALL AREAS OUTSIDE OF ASPHALT DRIVE TO BE 4" OF CLEAN NO. 2 STONE OVER WOVEN LANDSCAPE FABRIC, EXTEND UNDER FENCE.

SANITARY SEWER PUMP STATION LAYOUT—MINIMUM STANDARDS FOR 250 ULTIMATE EQUIVALENT DWELLING UNITS CONNECTED.\*

\*STATIONS REQUIRING MORE THAN 15 K.W. STANDBY POWER, (I.E., HIGH HEADS) ARE TO USE SKETCH "B"

STREET (TYP.)

**ERIE COUNTY**  
**DEPT. OF ENVIRONMENT & PLANNING**  
**DIVISION OF SEWERAGE MANAGEMENT**

Rev. 1	6/05	CHANGED LOT SIZE TO 50'x100'
Rev. 2		
File:	D-38	Date: 4/15/93

STD.DETAIL

38



# TYPICAL PUMP STATION "A" BUILDING LAYOUT (NOVEMBER 2023)

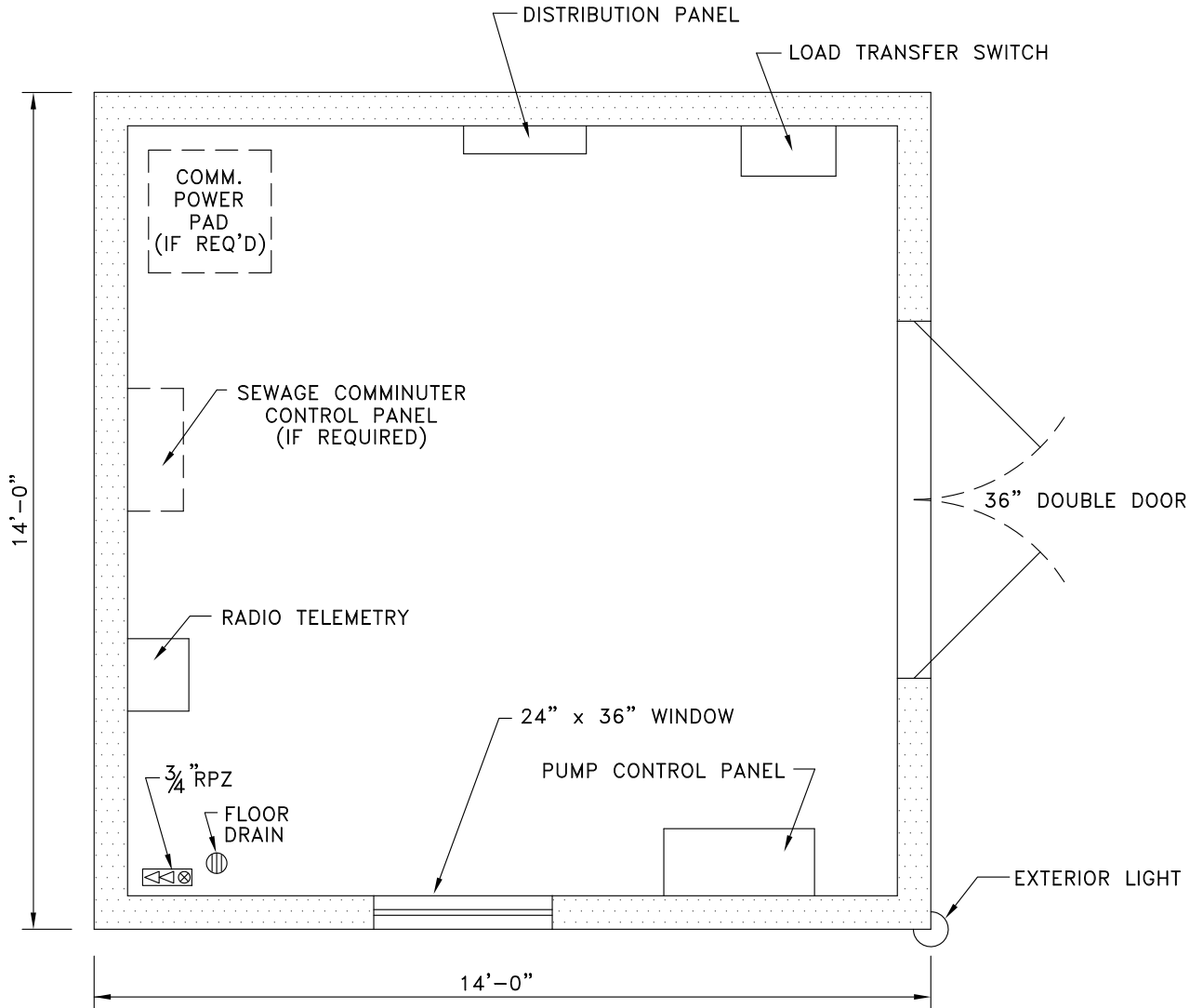

**NOTES:**

CONTROL PANEL SHALL BE DESIGNED FOR USE IN CLASS 1, DIVISION 1 AREAS. CONTROLS ARE TO BE INTRINSICALLY SAFE. A SPARE PUMP AND PORTABLE GENERATOR SHALL BE PROVIDED. THE GENERATOR SHALL BE SIZED TO OPERATE BOTH PUMPS CONCURRENTLY, INCLUDING: LIGHTS, CONTROLS & HEATERS.

JUNCTION BOX TO CONTAIN COMPRESSION TYPE TERMINAL STRIPS MOUNTED ON BACK PANEL. ALL CONDUCTORS AND TERMINALS TO BE PERMANENTLY MARKED. SPARE WIRE TO BE TERMINATED, 3 MOTOR HEADS & 4 CONTROL LEADS.

SCALE: 1"=3'

ERIE COUNTY  
DEPT. OF ENVIRONMENT & PLANNING  
DIVISION OF SEWERAGE MANAGEMENT

Rev. 1	ADDED NOTES
1/3/94	
Rev. 2	
File: D-39	Date: 4/15/93

STD.DETAIL

39

# TYPICAL PUMP STATION SKETCH "B"

(NOVEMBER 2023)

**NOTE:** LEFT HAND LAYOUT SHOWN, RIGHT HAND LAYOUT IS ACCEPTABLE.  
ALTERNATIVE LAYOUTS MAY BE SUBMITTED FOR APPROVAL

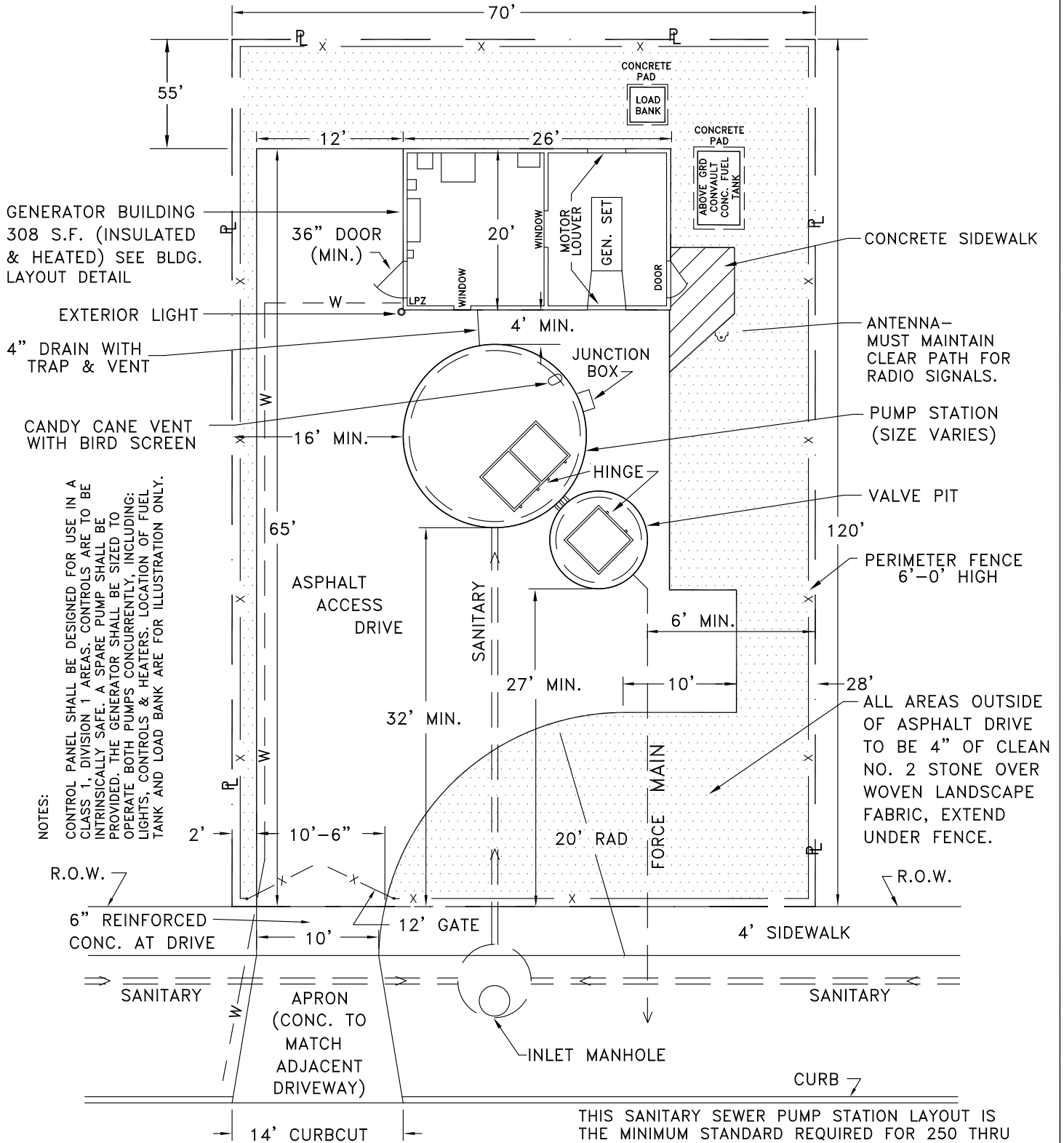

**NOTES:**  
CONTROL PANEL SHALL BE DESIGNED FOR USE IN A CLASS 1, DIVISION 1 AREAS. CONTROLS ARE TO BE INTRINSICALLY SAFE. A SPARE PUMP SHALL BE PROVIDED. THE GENERATOR SHALL BE SIZED TO OPERATE BOTH PUMPS CONCURRENTLY, INCLUDING: LIGHTS, CONTROLS & HEATERS. LOCATION OF FUEL TANK AND LOAD BANK ARE FOR ILLUSTRATION ONLY.

THIS SANITARY SEWER PUMP STATION LAYOUT IS THE MINIMUM STANDARD REQUIRED FOR 250 THRU 500 ULTIMATE EQUIVALENT DWELLING UNITS OR IF A GEN. SET GREATER THAN 15 K.W. IS REQUIRED.

**ERIE COUNTY**  
**DEPT. OF ENVIRONMENT & PLANNING**  
**DIVISION OF SEWERAGE MANAGEMENT**

2/7/94	LOAD BANK, GEN SET & FUEL TANK COMMENTS
12/28/00	SEPARATED GEN SET FROM CONTROL ROOM
6/05	CHANGED LOT SIZE TO 70' X 120'
10/3/17	MOVED FUEL TANK OUTSIDE

**STD.DETAIL**

40

File: D-40      Date: 4/15/93

File: V:\DSM\Engineering\CAD\Details\November 2023\0-40.dwg, Last saved: 12/7/2023, Plot Date: 12/12/2023, Plot Style: DETAILS.CTB

# TYPICAL PUMP STATION "B" BUILDING LAYOUT (NOVEMBER 2023)

WATER SERVICE AND BACKFLOW PREVENTER SHALL BE INSTALLED INSIDE OF CONTROL BUILDING, (SIZE TO BE DETERMINED BY D.S.M.). A FROST PROOF HOSE BIB SHALL BE INSTALLED ON THE OUTSIDE.

CONTROL PANEL SHALL BE DESIGNED FOR USE IN CLASS 1, DIVISION 1 AREAS. CONTROLS ARE TO BE INTRINSICALLY SAFE. A SPARE PUMP SHALL BE PROVIDED. THE GENERATOR SHALL BE SIZED TO OPERATE BOTH PUMPS CONCURRENTLY, INCLUDING: LIGHTS, CONTROLS & HEATERS. LOCATION OF FUEL TANK AND LOAD BANK ARE FOR ILLUSTRATION ONLY.

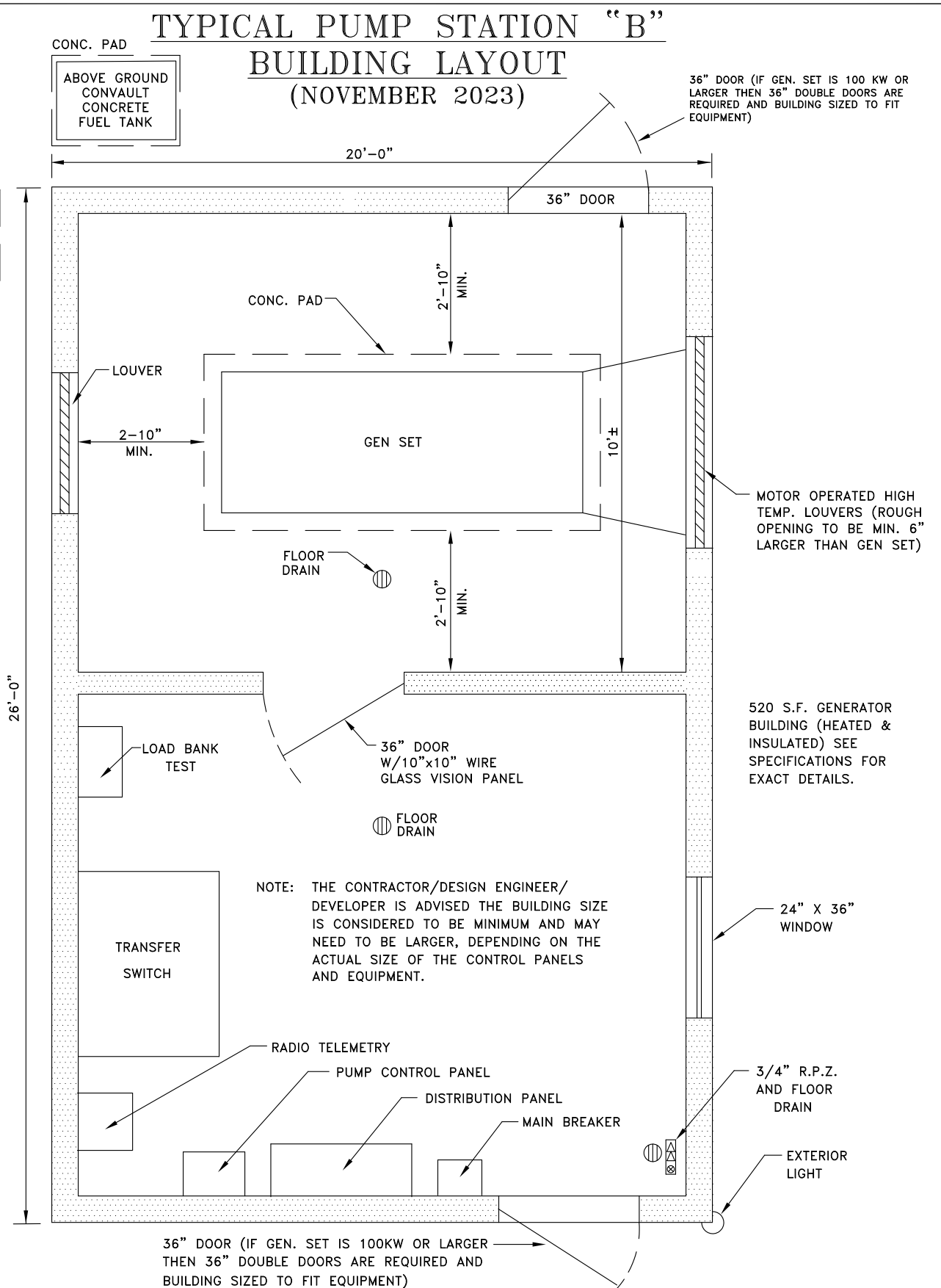

NOTE: THE CONTRACTOR/DESIGN ENGINEER/ DEVELOPER IS ADVISED THE BUILDING SIZE IS CONSIDERED TO BE MINIMUM AND MAY NEED TO BE LARGER, DEPENDING ON THE ACTUAL SIZE OF THE CONTROL PANELS AND EQUIPMENT.

36" DOOR (IF GEN. SET IS 100 KW OR LARGER THEN 36" DOUBLE DOORS ARE REQUIRED AND BUILDING SIZED TO FIT EQUIPMENT)

MOTOR OPERATED HIGH TEMP. LOUVERS (ROUGH OPENING TO BE MIN. 6" LARGER THAN GEN SET)

520 S.F. GENERATOR BUILDING (HEATED & INSULATED) SEE SPECIFICATIONS FOR EXACT DETAILS.

36" DOOR (IF GEN. SET IS 100KW OR LARGER THEN 36" DOUBLE DOORS ARE REQUIRED AND BUILDING SIZED TO FIT EQUIPMENT)

**ERIE COUNTY**  
**DEPT. OF ENVIRONMENT & PLANNING**  
**DIVISION OF SEWERAGE MANAGEMENT**

2/7/94	ADDED NOTES, FILLER CAP LOCK AND GEN SET/FUEL TANK COMMENTS
12/01	REVISED LAYOUT TO SHOW GEN/SET IN SEPARATE ROOM FROM CONTROLS
6/05	MOVED LOAD BANK TEST
9/14/17	ADDED ABOVE GRD FUEL TANK, REMOVED FUEL VENT
File: D-41	
Date: 4/15/93	

STD.DETAIL

41

# WETWELL-VALVE CHAMBER/TOP VIEW (NOVEMBER 2023)

4" OR 6" (AS REQUIRED BY DISTRICT)  
EMERGENCY PLUG VALVE SHALL BE DESIGNED  
TO PERMIT CONNECTION OF HARD PUMP HOSE.

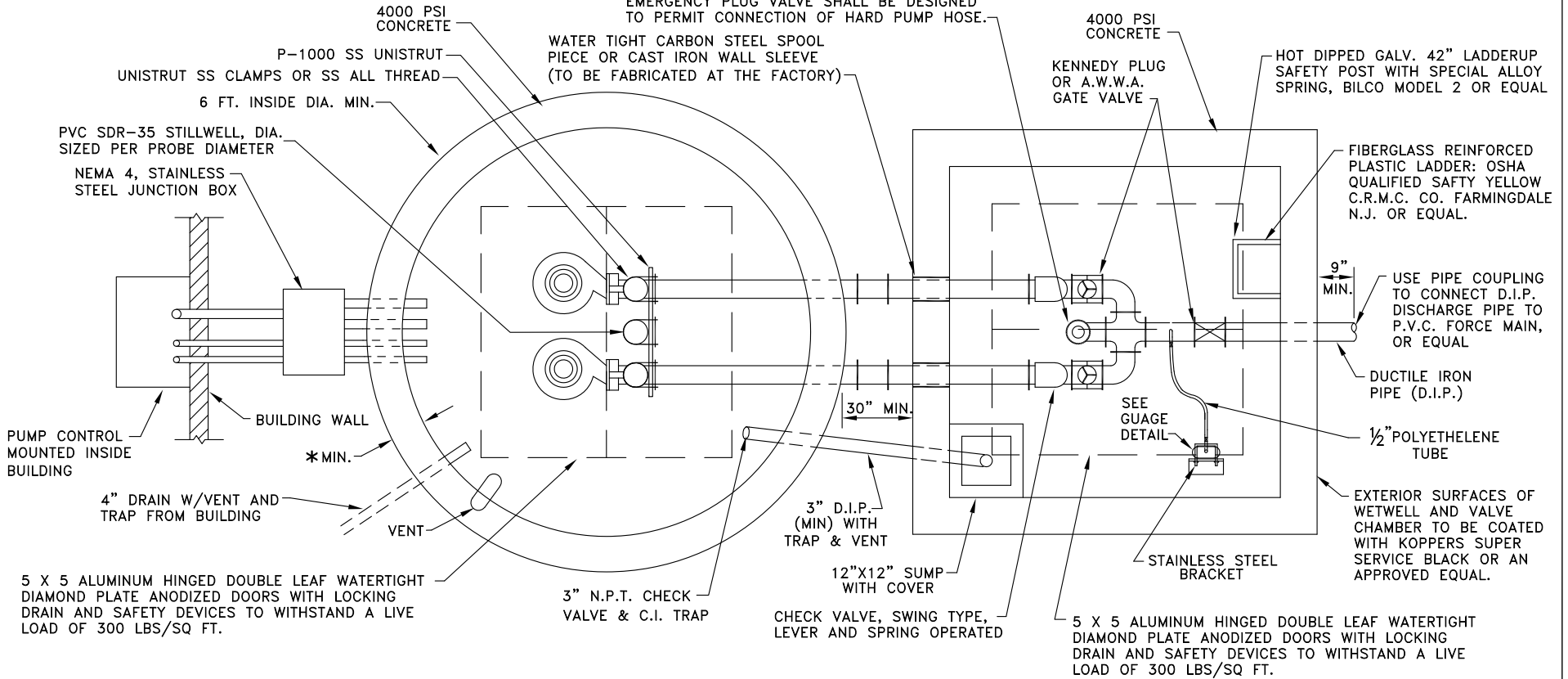

**NOTES:**

JUNCTION BOX TO CONTAIN COMPRESSION TYPE TERMINAL STRIPS MOUNTED ON BACK PANEL. ALL CONDUCTORS AND TERMINALS TO BE PERMANENTLY MARKED. SPARE WIRE TO BE TERMINATED, 3 MOTOR LEADS & 4 CONTROL LEADS.  
ALL PIPE FLANGES MUST EXTEND A MINIMUM OF 6" INSIDE VALVE CHAMBER.

ALL PIPING IN WETWELL AND VALVE PIT SHALL BE DUCTILE IRON MECHANICAL JOINT.  
CORBIN PADLOCK TO BE PROVIDED PER ERIE COUNTY SEWER DISTRICT KEYING REQUIREMENTS.

**ERIE COUNTY  
DEPT. OF ENVIRONMENT & PLANNING  
DIVISION OF SEWERAGE MANAGEMENT**

REV 02/94	REMOVED CONTROL PANEL NOTE AND CHANGED GAUGE LOCATION
REV 12/96	REVISED NOTES
REV 01/12	ADDED WALL SLEEVE NOTE TO CHAMBER
REV 08/18	ADDED STILLWELL

**File: D-42      Date: 4/15/93**

**STD. DETAIL**

42

# WETWELL-VALVE CHAMBER/SECTION

(NOVEMBER 2023)

PUMP CONTROL AND MAIN DISCONNECTS FOR RADIO TELEMTRY MOUNTED INSIDE BLDG.

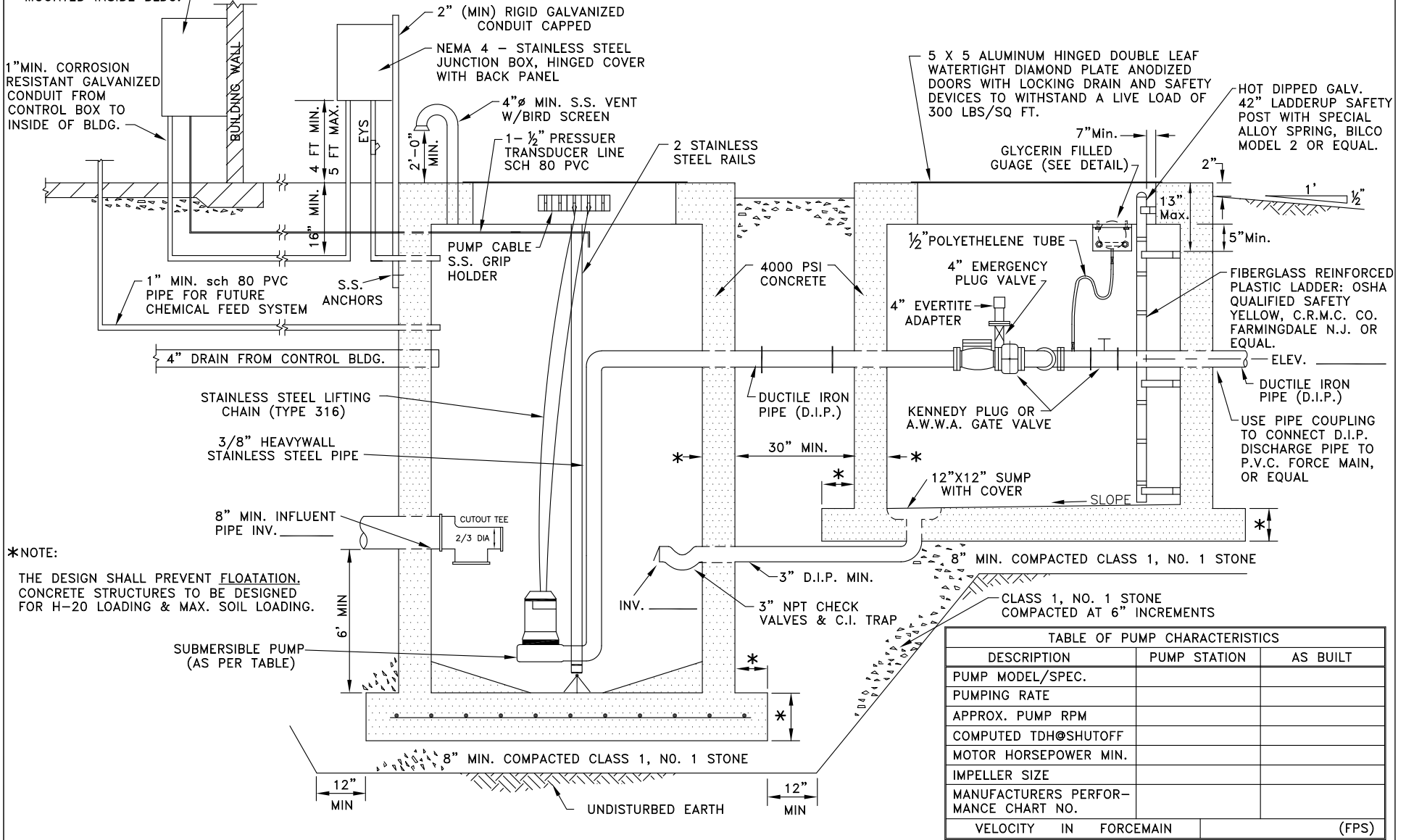

TABLE OF PUMP CHARACTERISTICS		
DESCRIPTION	PUMP STATION	AS BUILT
PUMP MODEL/SPEC.		
PUMPING RATE		
APPROX. PUMP RPM		
COMPUTED TDH@SHUTOFF		
MOTOR HORSEPOWER MIN.		
IMPELLER SIZE		
MANUFACTURERS PERFORMANCE CHART NO.		
VELOCITY	IN FORCEMAIN	(FPS)

**ERIE COUNTY**  
**DEPT. OF ENVIRONMENT & PLANNING**  
**DIVISION OF SEWERAGE MANAGEMENT**

REV 2/94	REMOVED REINFORCING NOTE
REV 6/05	ADDED C.I. TYPE TRAP & EYS
REV 01/12	REMOVED AIR BELL
REV 01/13	ADDED LADDER MIN. & MAX. DIMENSIONS
<b>File:</b>	<b>D-43</b>
<b>Date:</b>	<b>4/15/93</b>

**STD. DETAIL**

43

# WETWELL/SIDE VIEW (NOVEMBER 2023)

5 X 5 ALUMINUM HINGED DOUBLE LEAF WATERTIGHT DIAMOND PLATE ANODIZED DOORS WITH LOCKING DRAIN AND SAFETY DEVICES TO WITHSTAND A LIVE LOAD OF 300 LBS/SQ. FT.

THE LOWEST PHYSICAL AND/OR ARCHITECTURAL OPENING SHALL BE A MINIMUM OF ONE FOOT ABOVE THE PROJECTED 100 YR. FLOOD LEVEL AS DEPICTED ON THE "NATIONAL FLOOD INSURANCE RATE MAPS" COVERING THE STATION SITE. THE PUMP STRUCTURES, ELECTRICAL & MECHANICAL EQUIPMENT SHALL ALSO BE PROTECTED FROM PHYSICAL DAMAGE BY THE ONE HUNDRED (100) YEAR FLOOD.

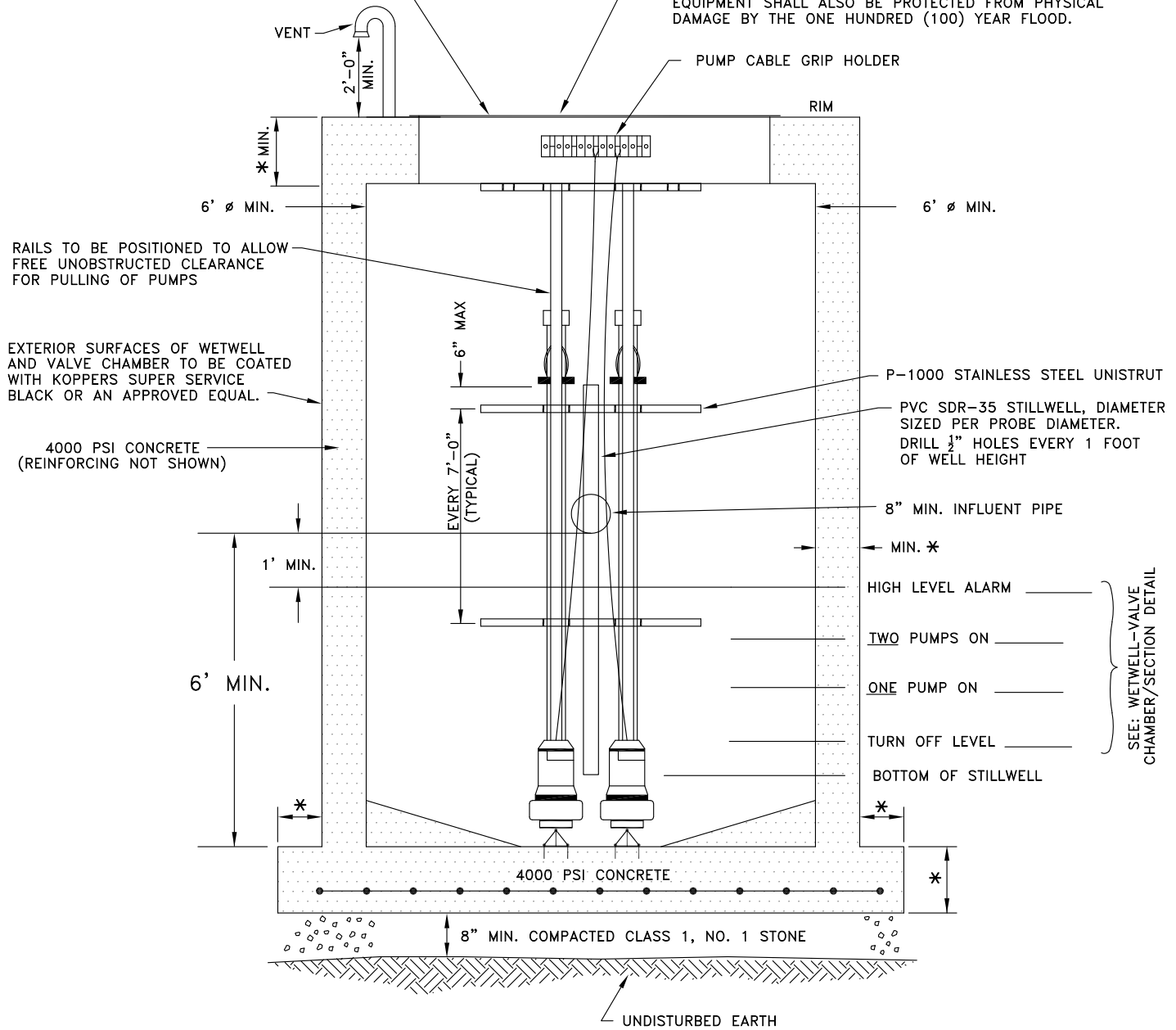

**NOTE:**

- \* 1. THE DESIGN SHALL PREVENT FLOATAION
- 2. ALL HARDWARE USED IN WETWELLS SHALL BE 316 STAINLESS STEEL.

**ERIE COUNTY**  
DEPT. OF ENVIRONMENT & PLANNING  
DIVISION OF SEWERAGE MANAGEMENT

REV 2/94	REMOVED REINFORCEMENT SPEC'S
REV 1/12	REMOVED BUBBLERS AND AIR BELLS
REV 8/18	ADDED STILLWELL

File: D-44      Date: 4/15/93

STD.DETAIL

44

# WETWELL JUNCTION BOX

(NOVEMBER 2023)

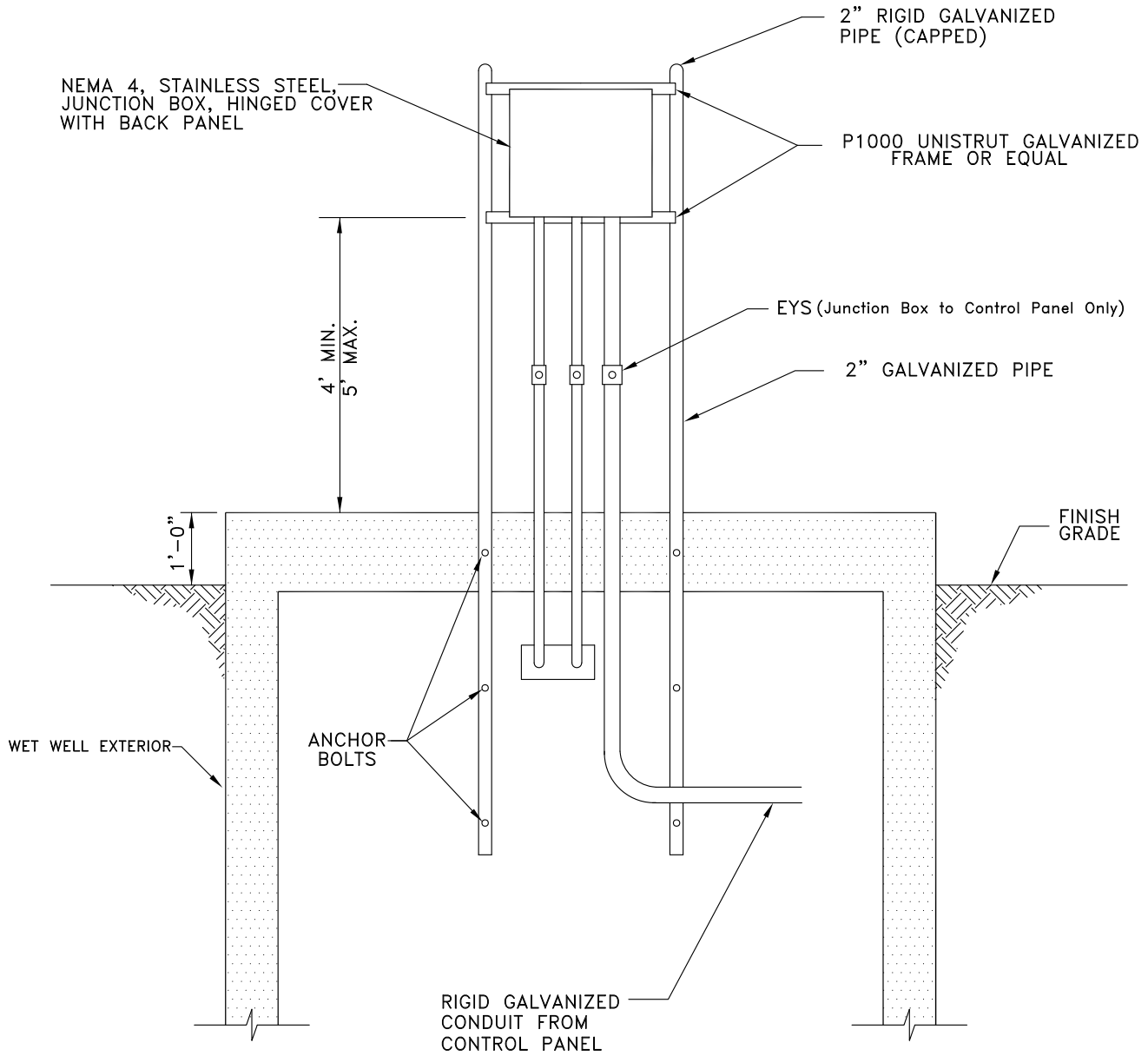

NOTE: JUNCTION BOX TO CONTAIN COMPRESSION TYPE TERMINAL STRIPS MOUNTED ON BACK PANEL. ALL CONDUCTORS AND TERMINALS TO BE MARKED PERMANENTLY. SPARE WIRES TO BE TERMINATED. 3 MOTOR LEADS AND 4 CONTROL LEADS.

ERIE COUNTY  
DEPT. OF ENVIRONMENT & PLANNING  
DIVISION OF SEWERAGE MANAGEMENT

Rev. 1  
8/17/18

Add EYS Note

STD.DETAIL

Rev. 2

File: D-45

Date: 4/15/93

45

# WETWELL/VALVE CHAMBER DETAILS

(NOVEMBER 2023)

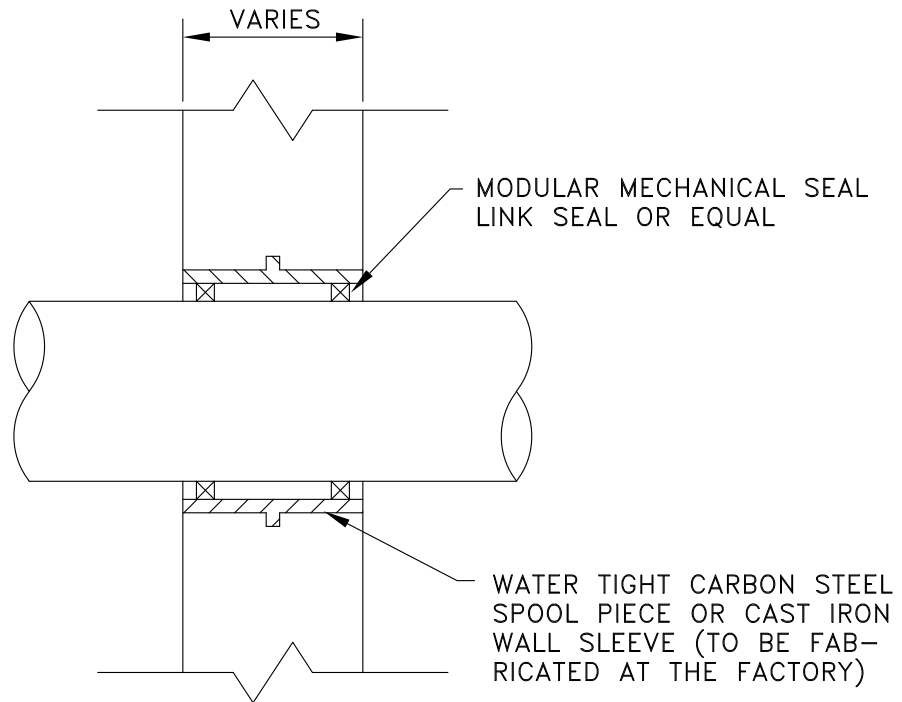

TYPICAL WALL PENETRATION  
VALVE PIT AND PUMP STATION

File: V:\DSM\Engineering\CAD\Details\Details November 2023\D-46.dwg. Last saved: 12/7/2023, Plot Date: 12/13/2023, Plot Style: DETAILS.CTB

**ERIE COUNTY**  
**DEPT. OF ENVIRONMENT & PLANNING**  
**DIVISION OF SEWERAGE MANAGEMENT**

REV 2/94	ADDED SS BOLTS TO SS CLAMPS
REV 1/12	DELETED BUBBLER & AIR BELL DETAIL
File:	D-46
Date:	4/15/93

STD.DETAIL

46



# GAUGE DETAIL

## (NOVEMBER 2023)

5 X 5 ALUMINUM HINGED DOUBLE LEAF  
WATERTIGHT DIAMOND PLATE ANODIZED  
DOORS WITH LOCKING DRAIN AND SAFETY  
DEVICES TO WITHSTAND LIVE LOAD OF  
300 LBS/SQ FT

CHAMBER DESIGN SHALL BE  
ABLE TO WITHSTAND H-20  
WHEEL LOADING (16,000 LBS)

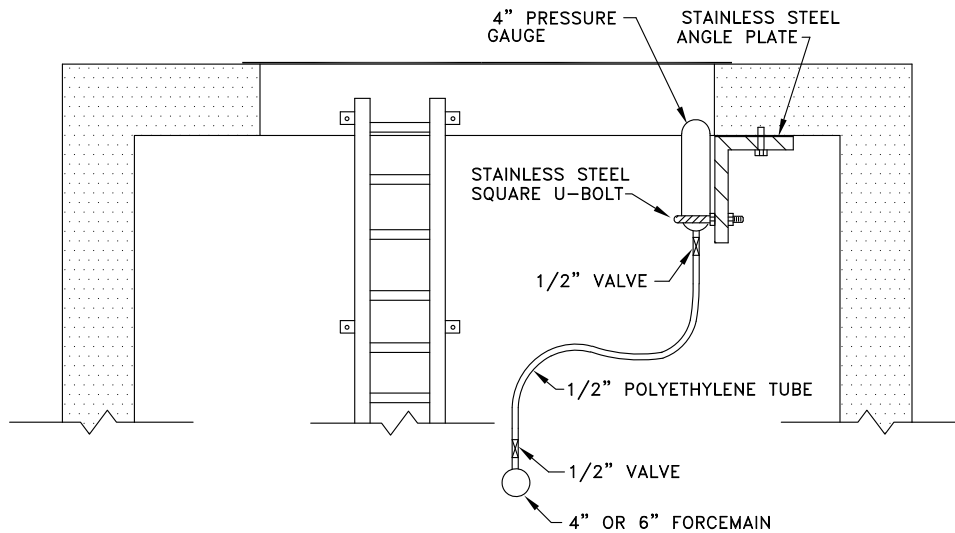
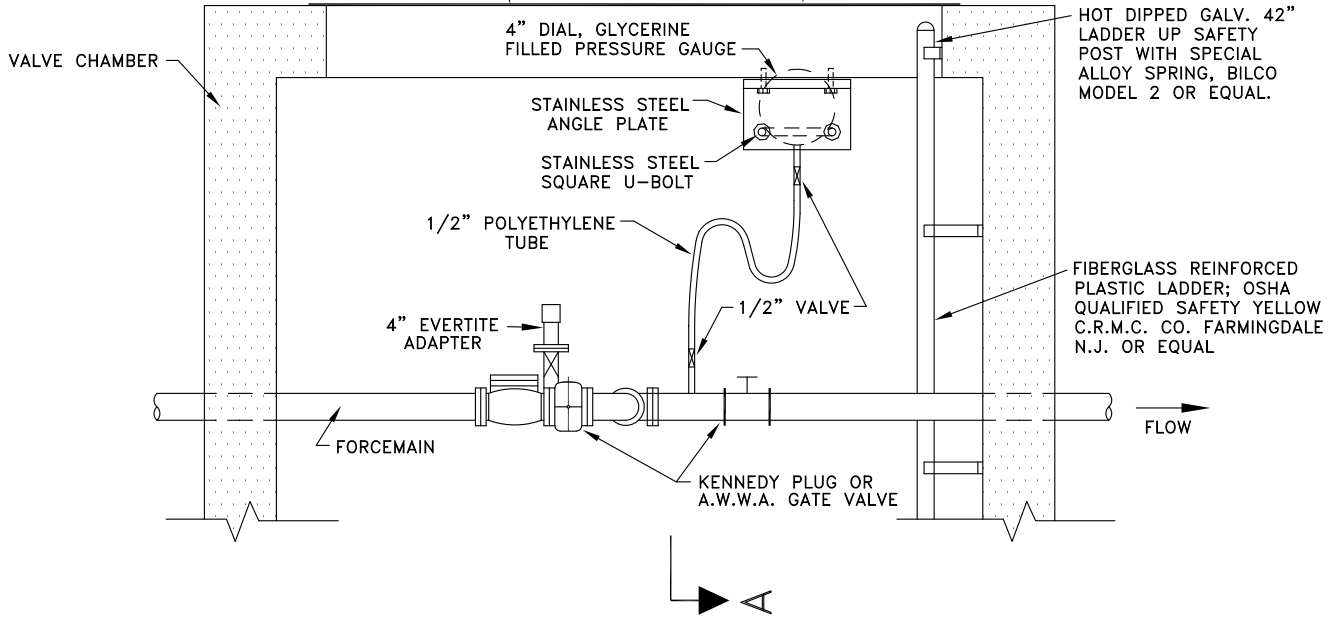

### SECTION A-A

NOT TO SCALE

**ERIE COUNTY**  
**DEPT. OF ENVIRONMENT & PLANNING**  
**DIVISION OF SEWERAGE MANAGEMENT**

Rev. 1 2/7/94	CHANGED LOCATION OF PRESSURE GAUGE
6/24/05	ADDED FLOW DIRECTION & H2O LOADING
6/1/18	REMOVED H2O LOADING

STD.DETAIL

47

File: D-47      Date: 4/15/93

# PUMP CABLE GRIP HOLDER

(NOVEMBER 2023)

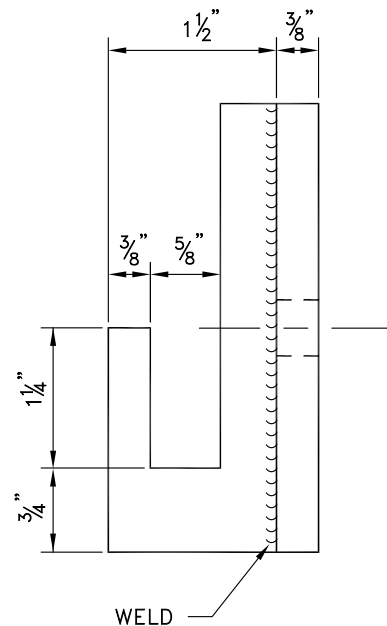
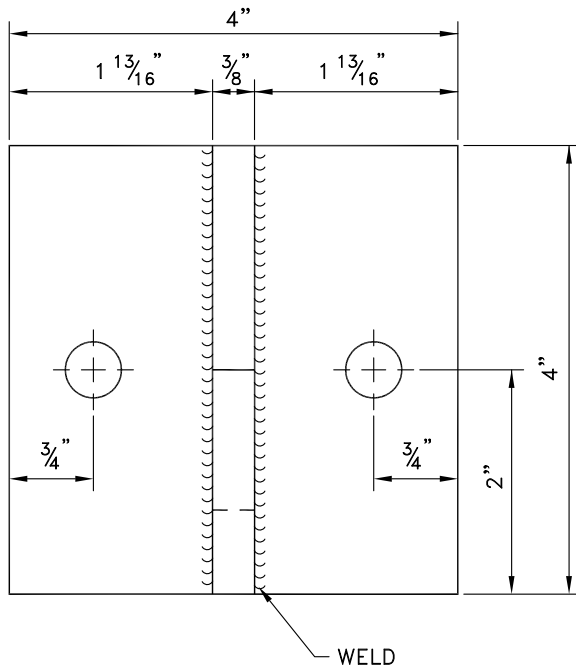
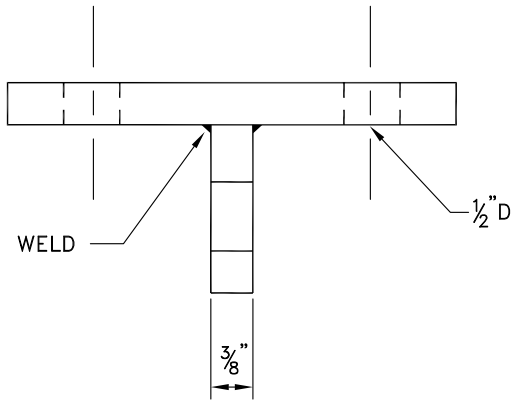

**NOTES:**

- 1)  $\frac{3}{8}$ " FLAT STOCK - 316 STAINLESS STEEL
- 2) PUMP CABLES WILL BE SUSPENDED FROM STAINLESS STEEL, SPLIT MESH, ROD CLOSING "KELLUMS" CABLE GRIPS. GRIPS WILL BE SIZED TO SECURELY HOLD CABLES BUT ALLOW EASY ADJUSTMENT.

NOT TO SCALE

**ERIE COUNTY**  
**DEPT. OF ENVIRONMENT & PLANNING**  
**DIVISION OF SEWERAGE MANAGEMENT**

<b>Rev. 1</b>	
<b>Rev. 2</b>	
<b>File:</b> D-48	<b>Date:</b> 4/15/93

STD.DETAIL

48

# SEWER AIR RELEASE VALVE AND MANHOLE

(NOVEMBER 2023)

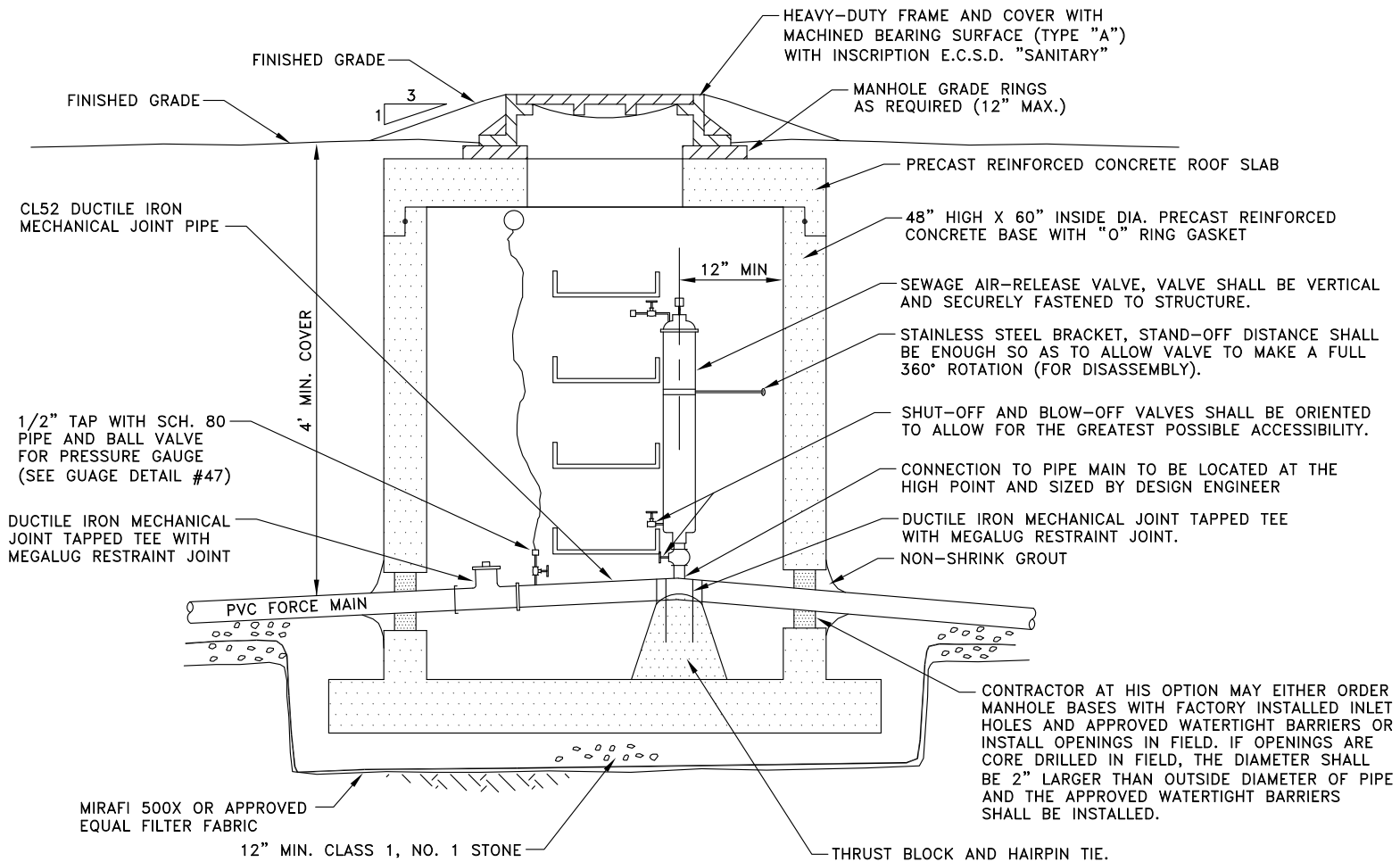

ERIE COUNTY  
DEPT. OF ENVIRONMENT & PLANNING  
DIVISION OF SEWERAGE MANAGEMENT

Rev. 1 2/7/94	FIXED LOCATION OF FILTER FABRIC, ADDED 12" MAX FOR GRADE RINGS, CHANGED STONE TO CLASS 1, NO. 1
Rev. 2 12/9/96	REVISED TEE/MECHANICAL JOINT, GAUGE NOTE. ADDED DRAINAGE PIPE AND NOTE.
Rev. 3 11/16/16	REMOVED MANHOLE FLOOR DRAIN AND CORRESPONDING NOTES
File: D-49	Date: 4/15/93

STD. DETAIL

49

# ROUND CONCRETE PIPE STEEL RING JOINT DETAIL

(NOVEMBER 2023)

JOINT COMPOUND AS RECOMMENDED BY MANUFACTURER SHALL BE BUTTERED ON SPIGOTS PRIOR TO ASSEMBLING THE PIPE. COMPOUND SHALL BE PLACED EXACTLY AS SHOWN, IN ORDER TO AVOID INTERFERENCE WITH THE INSTALLATION OF THE GASKET.

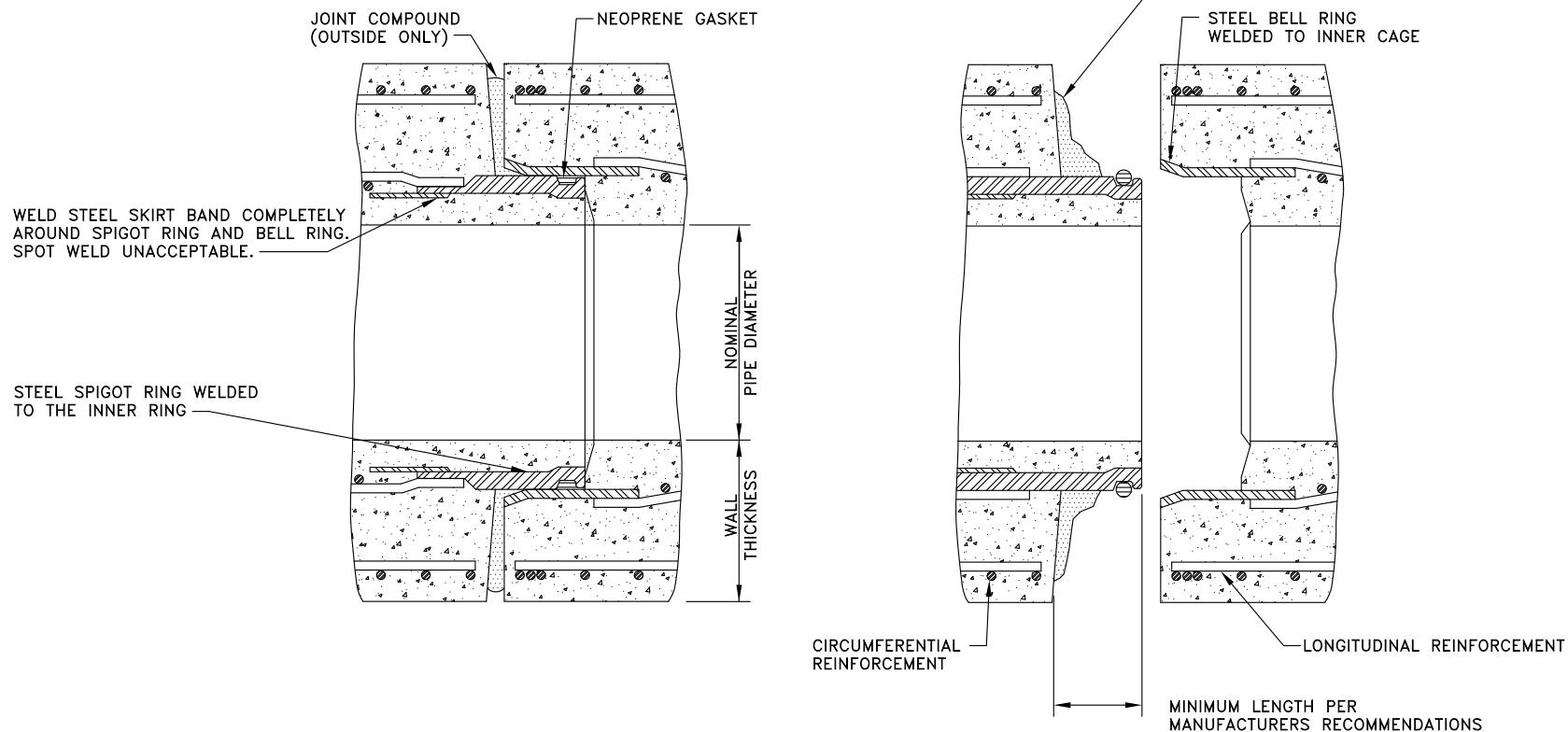

NO SCALE

ERIE COUNTY  
DEPT. OF ENVIRONMENT & PLANNING  
DIVISION OF SEWERAGE MANAGEMENT

Rev. 1

Rev. 2

File: D-50

Date: 12/9/96

STD. DETAIL

50

# FORCE MAIN MARKER

(NOVEMBER 2023)

NO SCALE

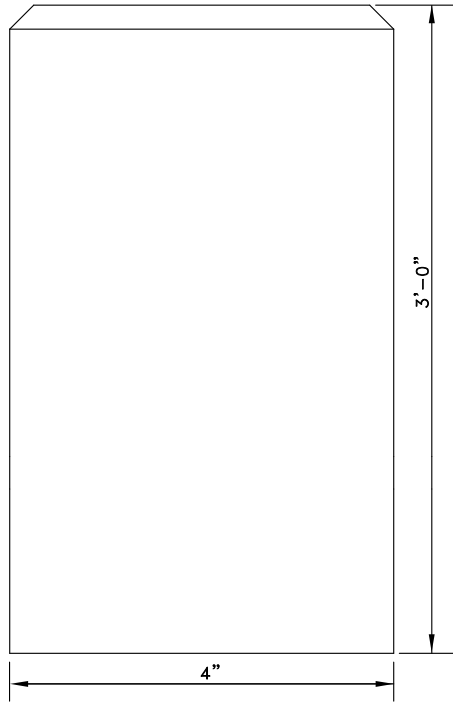
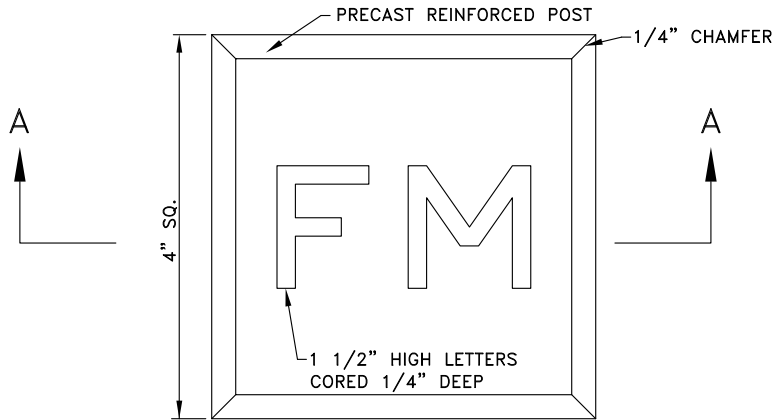

SECTION A-A

**NOTES:**

1. THE CONTRACTOR SHALL PROVIDE A 4 INCH SQUARE REINFORCED CONCRETE POST, 3 FEET LONG, BURIED IN A VERTICAL POSITION WITH THE LETTERS FM ENGRAVED ON THE TOP, FLUSH WITH THE GROUND SURFACE & MEET THE ENGINEER'S APPROVAL. (TO BE INCLUDED IN THE PIPE BID ITEM)
2. AFTER CONSTRUCTION OF FORCE MAIN, EACH MARKER IS TO BE LOCATED IN THE FIELD BY A LICENSED LAND SURVEYOR AT THE CONTRACTOR'S EXPENSE. LOCATIONS AND TIES TO BE INCLUDED ON RECORD PLANS.
3. MARKER IS REQUIRED EVERY 500' AND AT ALL FORCE MAIN CHANGES OF DIRECTION.

**ERIE COUNTY  
DEPT. OF ENVIRONMENT & PLANNING  
DIVISION OF SEWERAGE MANAGEMENT**

Rev. 1	ADDED SECTION A-A
6/9/05	& NOTE 3

Rev. 2	
--------	--

File: D-51	Date: 12/9/96
------------	---------------

STD.DETAIL

51

# EXISTING CLEANOUT REMOVAL

(NOVEMBER 2023)

EXISTING CLEANOUT TO BE REMOVED.  
CAP TO BE RETURNED TO SEWER DISTRICT

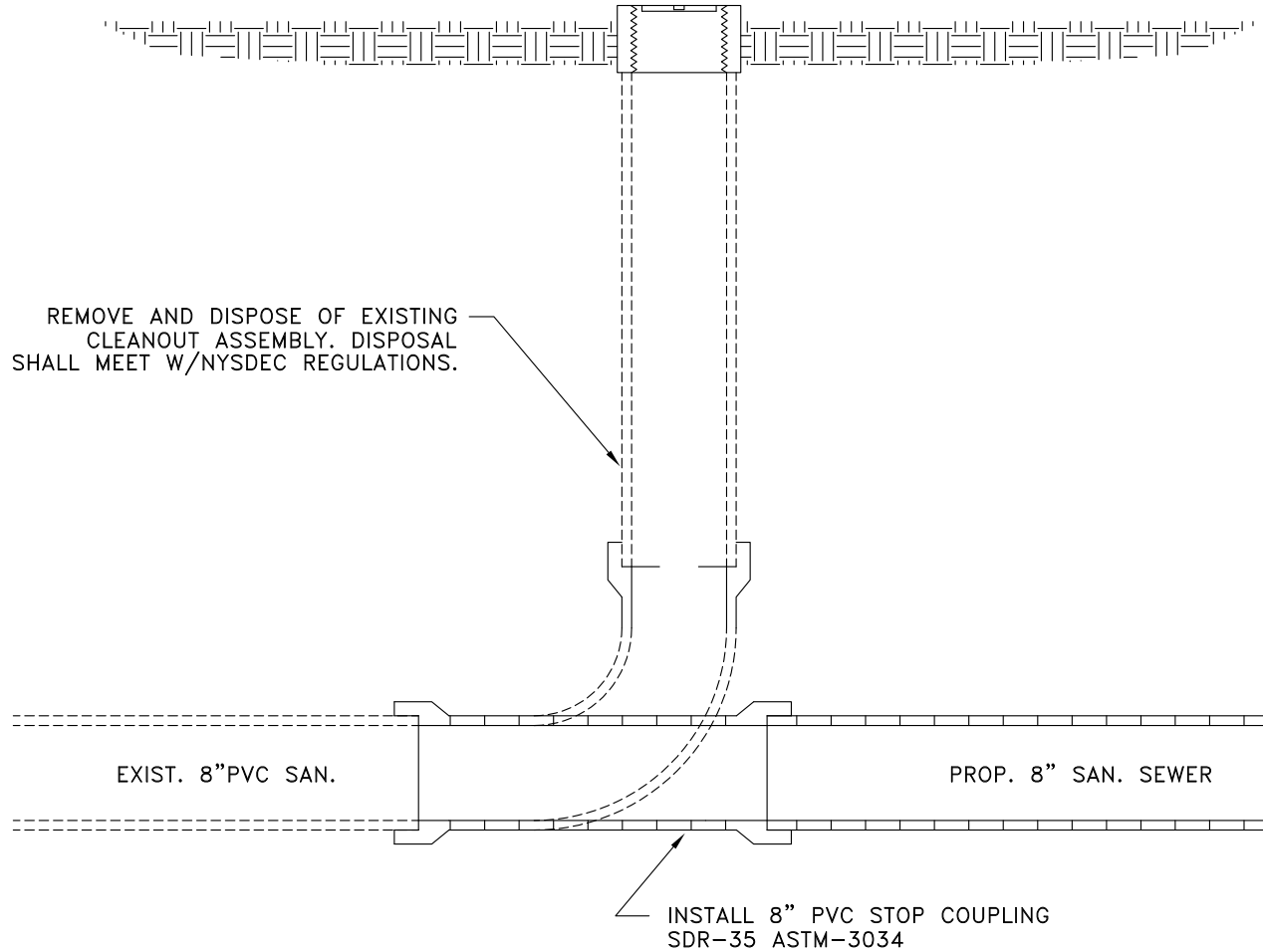

ERIE COUNTY  
DEPT. OF ENVIRONMENT & PLANNING  
DIVISION OF SEWERAGE MANAGEMENT

Rev. 1	
Rev. 2	
File: D-52	Date: 12/6/96

STD. DETAIL

52

# Cleanout in Pavement/Sidewalks

(NOVEMBER 2023)

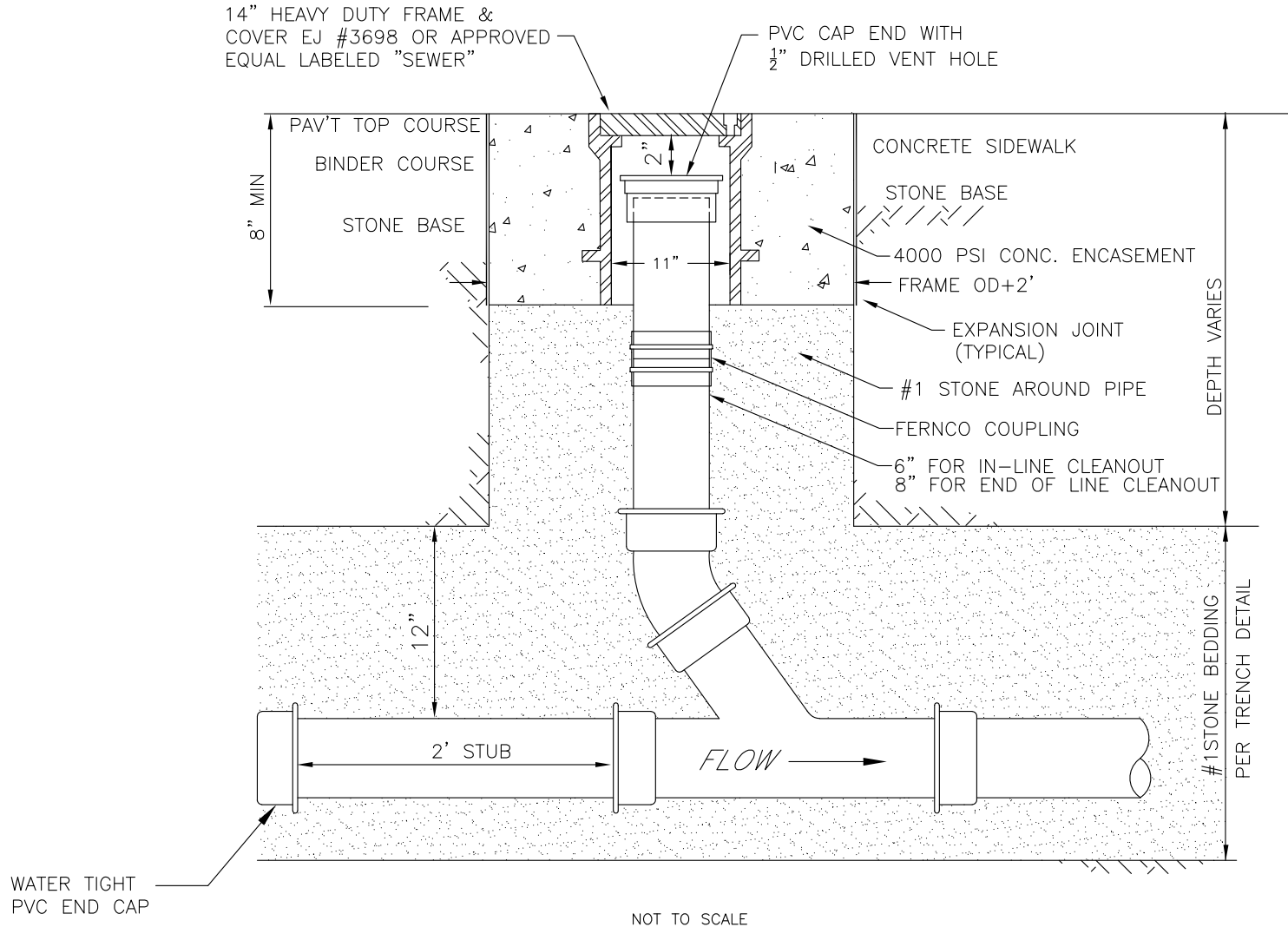

**ERIE COUNTY**  
**DEPT. OF ENVIRONMENT & PLANNING**  
**DIVISION OF SEWERAGE MANAGEMENT**

REV 07/99	ADD MIN. DISTANCE AND MARKER
REV 12/01	ADDED #1 STONE AROUND PIPE
REV 01/12	REMOVED 2X4 MARKER
REV 11/23	ADD FERNCO COUPLING & EJ 3698

**File: D-53**

**Date: 5/13/97**

**STD. DETAIL**

53

# CLEANOUT DETAIL

## END OF LINE

(NOVEMBER 2023)

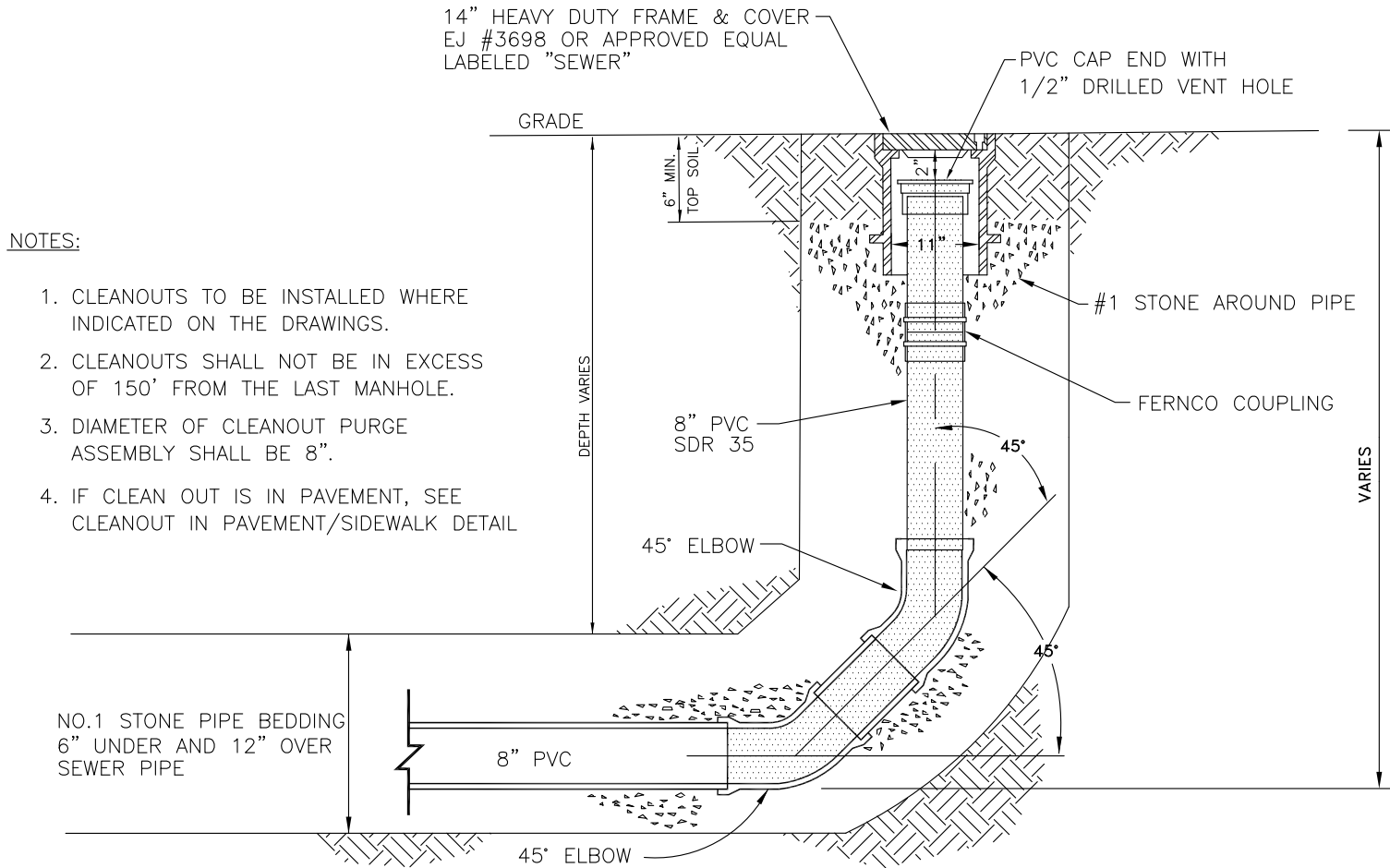

**NOTES:**

1. CLEANOUTS TO BE INSTALLED WHERE INDICATED ON THE DRAWINGS.
2. CLEANOUTS SHALL NOT BE IN EXCESS OF 150' FROM THE LAST MANHOLE.
3. DIAMETER OF CLEANOUT PURGE ASSEMBLY SHALL BE 8".
4. IF CLEAN OUT IS IN PAVEMENT, SEE CLEANOUT IN PAVEMENT/SIDEWALK DETAIL

File: V:\DSM\Engineering\CAD\Details\Details November 2023\D-54.dwg, Last saved: 12/13/2023, Plot Date: 12/14/2023, Plot Style: DETAILS.CTB

**ERIE COUNTY**  
**DEPT. OF ENVIRONMENT & PLANNING**  
**DIVISION OF SEWERAGE MANAGEMENT**

Rev. 1	11/23	ADDED FERNCO COUPLING & EJ #3698
File:	D-54	Date: 8/2005

STD. DETAIL

54



# CLAY DAM RELIEF PIPE

(NOVEMBER 2023)

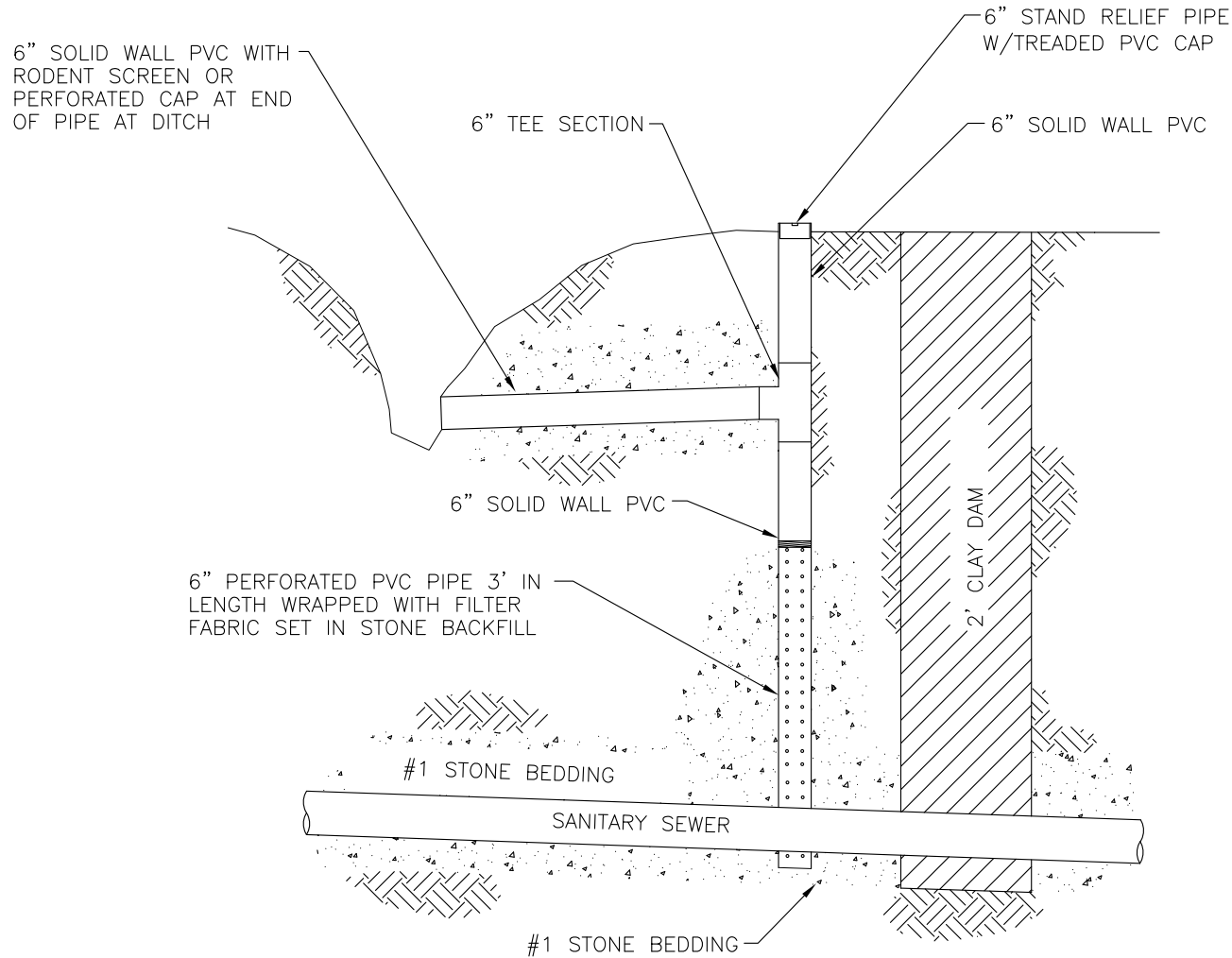

ERIE COUNTY  
DEPT. OF ENVIRONMENT & PLANNING  
DIVISION OF SEWERAGE MANAGEMENT

Rev. 1	
Rev. 2	
Rev. 3	
File:	D-55
Date:	12/2001

STD. DETAIL

55

# STEEP SLOPE SANITARY SEWER PROTECTION CONCRETE ANCHOR COLLAR DETAILS (NOVEMBER 2023)

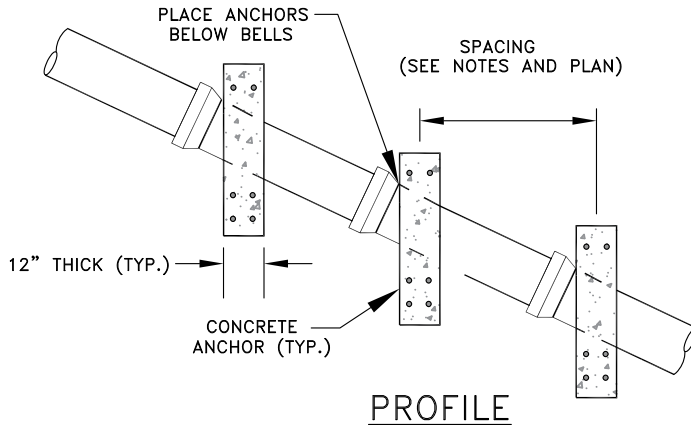

**NOTES:**

1. CONCRETE SLOPE ANCHOR REQUIRED FOR ALL SANITARY SEWER MAINS WITH SLOPE GREATER THAN OR EQUAL TO 20%.
2. PLACE CLEANOUT ON HIGH SIDE OF ANCHOR COLLAR WHEN REQUIRED.
3. MAXIMUM ANCHOR SPACING SHALL BE AS FOLLOWS:

PIPE SLOPE	MAX. SPACING
20% TO 35%	36"
35% TO 50%	24"
OVER 50%	16"

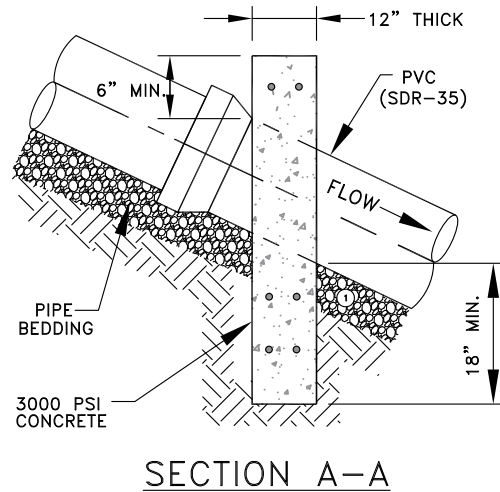
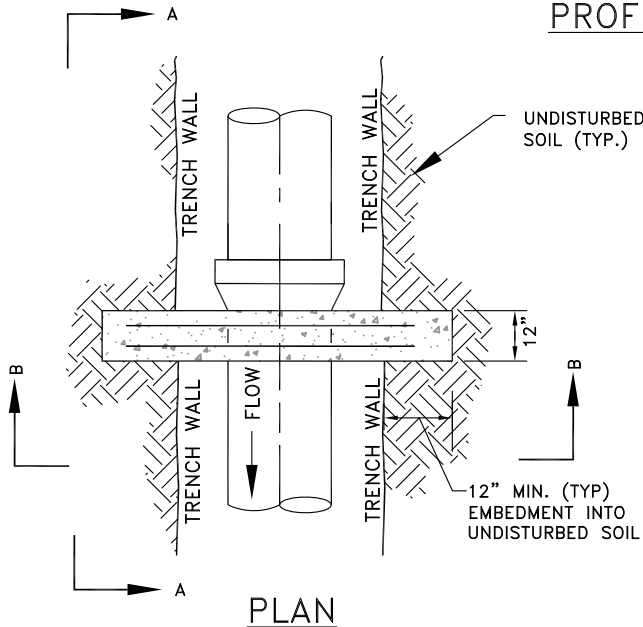

**MATERIALS**

**PIPE BEDDING MATERIAL (NYS DOT LATEST EDITION)**

① NO.1 CRUSHED STONE WITH A GRADATION CONFORMING WITH NYSDOT SECTION 703-02. THE CRUSHED STONE SHALL BE WELL GRADED WITH NO PARTICLES LARGER THAN 1" AND HAVING A MAXIMUM GRADATION MEETING THE LIMITS DESCRIBED IN THE SPECIFICATIONS. THE BEDDING SHALL BE COMPACTED IN 6" LIFTS WITH EQUIPMENT ACCEPTABLE TO THE PIPE MANUFACTURER.

NOTE: SLAG SHALL NOT BE ALLOWED FOR MATERIALS.

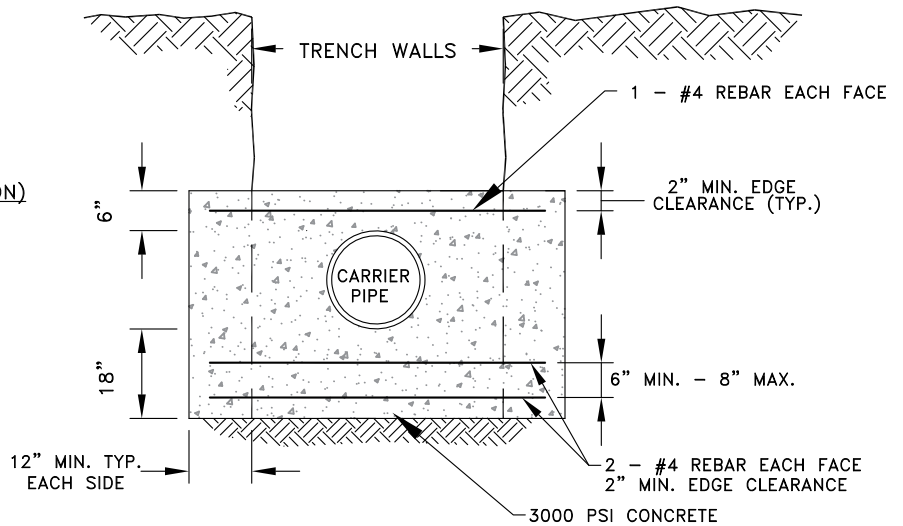

**ERIE COUNTY  
DEPT. OF ENVIRONMENT & PLANNING  
DIVISION OF SEWERAGE MANAGEMENT**

Rev. 1

Rev. 2

File: D-56

Date: 7/12/22

STD.DETAIL

56

**APPENDIX E**

**TESTING FORMS**

## SANITARY SEWER AIR TEST

**ERIE COUNTY DEPARTMENT OF ENVIRONMENT AND PLANNING  
DIVISION OF SEWERAGE MANAGEMENT**

ECSD No: \_\_\_\_\_ Mini System: \_\_\_\_\_ Inspector: \_\_\_\_\_

Project Name: \_\_\_\_\_ Pipe Size & Material: \_\_\_\_\_

Contractor Name: \_\_\_\_\_ Date Trench Backfilled: \_\_\_\_\_

Mailing Address: \_\_\_\_\_ Date of Test: \_\_\_\_\_

THIS TEST SHALL BE PERFORMED NO EARLIER THAN 14 CALENDAR DAYS AFTER THE TRENCH HAS BEEN BACKFILLED.

MH	to	MH	Air Pressure (psi)		Time		Time Elapsed	Pressure Drop	Comments
			Start	Finish	Start	Finish			

Reviewed By: \_\_\_\_\_ Date: \_\_\_\_\_

- 1. Clock time by hour and minute after pressure is stabilized. Extend test time to next full minute.
- 2. See reverse side for minimum times required for less than 0.5 psi pressure drop.

Minimum Acceptance Times\* For Length Shown (min:sec)

Pipe Diameter	Up to 100'	100 - 200'	200 - 300'	300 - 400'
6"	2:50	2:50	2:50	2:51
8"	3:47	3:47	3:48	5:04
10"	4:43	4:43	5:56	7:54
12"	5:40	5:42	8:33	11:24
15"	7:05	8:54	13:21	17:48
18"	8:30	12:49	19:14	25:38
21"	9:55	17:27	26:11	34:54
24"	11:24	22:48	34:11	45:35
27"	14:25	28:51	43:16	57:42
30"	17:48	35:37	53:25	71:13
33"	21:33	43:56	64:38	86:10
36"	25:39	51:17	76:55	102:34

\* The Erie County Sewer District Inspector during the test will extend time to the next full minute.

**SANITARY SEWER EXFILTRATION TEST**  
**ERIE COUNTY DEPARTMENT OF ENVIRONMENT AND PLANNING**  
**DIVISION OF SEWERAGE MANAGEMENT**

ECSD NO: \_\_\_\_\_ MINI SYSTEM: \_\_\_\_\_ SEWER INSPECTOR: \_\_\_\_\_  
 Project Name: \_\_\_\_\_ Pipe Size & Material: \_\_\_\_\_  
 Contractor Name: \_\_\_\_\_ Date Construction Started: \_\_\_\_\_  
 Mailing Address: \_\_\_\_\_ Date Trench Backfilled: \_\_\_\_\_  
 \_\_\_\_\_

MH to MH	Length of Section (ft.)	Water Table* (inches)	Cone Taper Length	Rim to Top of Cone (inches)	Start Test			End Test			Loss in Inches	Exfiltration	
					Date	Time	Water	Date	Time	Water		Actual	Allowable***

Reviewed By: \_\_\_\_\_ DATE: \_\_\_\_\_

\* Distance in inches from top of pipe to top of water table.  
 \*\* Distance in inches from rim to water level measured in upstream manhole of the section tested.

- NOTES:
- 1) Water level in testing manholes shall cover frame flange
  - 2) The allowable exfiltration shall be based on the shortest segment between manholes in the section tested, but not less than 100 feet.
  - 3) In a four (4) foot diameter barrel section each one (1) inch drop equates to 7.83 gallons actually lost.
  - 4) In a five (5) foot diameter barrel section each one (1) inch drop equates to 12.24 gallons actually lost.

Pipe Diameter (inches)	***Allowable per 100' (G.P.D.)	Pipe Diameter (inches)	***Allowable per 100' (G.P.D.)
8	15.15	12	22.73
10	18.94	15	28.41

For larger diameter pipe, refer to Section 02595 - 3.02 of the Specifications for Subdivisions & Sanitary Sewer Extensions.

**SANITARY SEWER INFILTRATION TEST (WEIR TEST)**  
**ERIE COUNTY DEPARTMENT OF ENVIRONMENT AND PLANNING**  
**DIVISION OF SEWERAGE MANAGEMENT**

ECSD NO: \_\_\_\_\_ Mini System: \_\_\_\_\_ Inspector: \_\_\_\_\_  
 Project Name: \_\_\_\_\_ Pipe Size & Material: \_\_\_\_\_  
 Contractor Name: \_\_\_\_\_ Date Trench Backfilled: \_\_\_\_\_  
 Mailing Address: \_\_\_\_\_ Date of Test: \_\_\_\_\_  
 \_\_\_\_\_ Weir Type: \_\_\_\_\_

THIS TEST SHALL BE PERFORMED NO EARLIER THAN 14 CALENDAR DAYS AFTER THE TRENCH HAS BEEN BACKFILLED. INFILTRATING WATER SHALL BE ALLOWED TO BUILD UP AND LEVEL OFF BEHIND THE WEIR UNTIL STEADY-UNIFORM FLOW IS OBTAINED. LEAKAGE IS DETERMINED BY DIRECT READING CONSECUTIVELY FOR FIVE (5) DAYS.

MH	to	MH	Length of Section	Water Table*	Weir Location	Readings		Infiltration (GPD)		Comments
						Date	Time	Actual	Allowable**	

REVIEWED BY: \_\_\_\_\_

DATE: \_\_\_\_\_

\* Distance from top of pipe to top of water table elevation.  
 The water table must be at least 2 feet above the top of the pipe at each manhole for the duration (5-days) of the test.

Pipe Diameter (inches)	** Allowable per 100' (GPD)	Pipe Diameter (inches)	** Allowable per 100' (GPD)
8	15.15	12	22.73
10	18.94	15	28.41

For larger diameter pipe, refer to Section 02595 - 3.02 of the Specifications for Subdivisions & Sanitary Sewer Extensions.

## SANITARY SEWER DEFLECTION TEST

**ERIE COUNTY DEPARTMENT OF ENVIRONMENT AND PLANNING  
DIVISION OF SEWERAGE MANAGEMENT**

ECSD No: \_\_\_\_\_ Mini System: \_\_\_\_\_ Inspector: \_\_\_\_\_

Project Name: \_\_\_\_\_ Pipe Size & Material: \_\_\_\_\_

Contractor Name: \_\_\_\_\_ Date Construction Started: \_\_\_\_\_

Mailing Address: \_\_\_\_\_ Date Trench Backfilled: \_\_\_\_\_

\_\_\_\_\_ Date of Test: \_\_\_\_\_

Type:  Mandrel                       Dimension Checked                       Go-No-Go Pig

THIS TEST SHALL BE PERFORMED NO EARLIER THAN 30 CALENDAR DAYS AFTER THE TRENCH HAS BEEN BACKFILLED.

MH	to	MH	Length of Section	Passed	Comments

Reviewed By: \_\_\_\_\_ Date: \_\_\_\_\_



**MANHOLE VACUUM TEST**  
**ERIE COUNTY DEPARTMENT OF ENVIRONMENT AND PLANNING**  
**DIVISION OF SEWERAGE MANAGEMENT**

ECSD No: \_\_\_\_\_ Mini System: \_\_\_\_\_ Date of Test: \_\_\_\_\_  
 Project Name: \_\_\_\_\_ Inspector: \_\_\_\_\_  
 Contractor Name: \_\_\_\_\_  
 Mailing Address: \_\_\_\_\_

NOTE: All manhole vacuum tests will be conducted as per Specification Section 02376.

Manhole #	Manhole Diameter	Manhole Depth	Time Required	Vacuum		Pass / Fail	Comments
				Start	Finish		

Reviewed By: \_\_\_\_\_ Date: \_\_\_\_\_

SANITARY FORCE MAIN LEAKAGE

ERIE COUNTY DEPARTMENT OF ENVIRONMENT & PLANNING  
DIVISION OF SEWERAGE MANAGEMENT

ECSD No. \_\_\_\_\_ Inspector: \_\_\_\_\_  
Project Name: \_\_\_\_\_ Date Construction Started: \_\_\_\_\_  
Contractor Name: \_\_\_\_\_ Date Pipe Backfilled: \_\_\_\_\_  
\_\_\_\_\_ Date of Test: \_\_\_\_\_  
\_\_\_\_\_

Section Tested Sta. \_\_\_\_\_ to Sta. \_\_\_\_\_

Pipe Diameter \_\_\_\_\_

Pipe Material \_\_\_\_\_

Pipe Footage Tested \_\_\_\_\_ L.F.

Time Started \_\_\_\_\_

Time Finished \_\_\_\_\_

Elapsed Time \_\_\_\_\_

Test Pressure (Start) \_\_\_\_\_ PSI

Test Pressure (End) \_\_\_\_\_ PSI

Allowable Leakage Per Specification \_\_\_\_\_ Gallons

Measured Leakage (Test) \_\_\_\_\_ Gallons

Pass \_\_\_\_\_ Fail \_\_\_\_\_

\_\_\_\_\_  
Inspector

\_\_\_\_\_  
Date

\_\_\_\_\_  
Reviewed By

\_\_\_\_\_  
Date

**APPENDIX F**

**I & I CONTRIBUTION  
SOURCE TABLE**

## I & I CONTRIBUTION SOURCE TABLE

Problem Type	Severity	I&I Contribution (gpm)
<b>Manholes</b>		
Surface Water/Low-lying Manholes/Inflow Protector Installed		4
Frame, Cone, Barrel leaks (not along joints)	Slight	0.5
	Moderate	1
	Severe	2
Joint leaks	Slight	1
	Moderate	3
	Severe	5
Exposed frame and cone in ditch (Exterior)	Slight	5
	Moderate	10
	Severe	15
Manhole replacement needed		10
Cracks in the concrete or paved surface area surrounding a manhole with leaks in frame and cone		10
<b>Pipe Segments</b>		
Joint infiltration or Cracked pipe		1
Pipe broken		2
Leaking lateral at the connection to the main		1
Sliplining Required/100 feet	8" pipe	1.1
	10" pipe	1.25
	12" pipe	1.5
	15" pipe	1.88
	18" pipe	2.25
<b>Private Sources</b>		
Low-lying lawn vent	General	0.1 to 80
	Missing/Wrong Vent Cap	value used 0.1
	Low Lying Vent	value used 1
	Loose/Broken Vent Riser	value used 10
Downspout		5
Sump pump		1
Defective residential lateral	Case-specific, no general classification	range 15 to 70 value used 30

# **APPENDIX G**

## **INDUSTRIAL WASTEWATER SURVEY**

**G – 1 COUNTY OF ERIE WRRF**

**G – 2 BUFFALO SEWER AUTHORITY**

**G – 3 AMHERST WWTP**

**G – 1 COUNTY OF ERIE WRRF**

COUNTY OF ERIE  
INDUSTRIAL WASTE SURVEY/DISCHARGE PERMIT APPLICATION

ECSD #2 - BIG SISTER WATER RESOURCE RECOVERY FACILITY  
ECSD #3 - SOUTHTOWNS ADVANCED WASTEWATER TREATMENT FACILITY  
ECSD #3 - HOLLAND WATER RESOURCE RECOVERY FACILITY  
ECSD #6 - LACKAWANNA WATER RESOURCE RECOVERY FACILITY  
ECSD #8 - EAST AURORA WATER RESOURCE RECOVERY FACILITY

I GENERAL INFORMATION

A. Standard Industrial Classification Code (S.I.C.) for Primary Activity (If not known, leave blank) \_\_\_\_\_

B. Company Name \_\_\_\_\_

C. Address of Premises \_\_\_\_\_

D. Mailing Address (If different than above) \_\_\_\_\_

E. Section, Block and Lot Number \_\_\_\_\_

F. Person to be contacted about this application:

Name: \_\_\_\_\_ Title: \_\_\_\_\_  
Phone: \_\_\_\_\_

G. The information contained in this application is familiar to me and the best of my knowledge and belief, such information is true, complete and accurate.

Date: \_\_\_\_\_ Signature \_\_\_\_\_  
(Owner or Corporate Official)

II PLANT OPERATION CHARACTERISTICS

A. Brief description of manufacturing or service activity on premises:

\_\_\_\_\_  
\_\_\_\_\_  
\_\_\_\_\_

B. Standard Industrial Classification (S.I.C.) Codes for Principal Products or Services (if S.I.C. Code is not known leave that portion of the answer blank)

<u>Product or Services</u>	<u>S.I.C. Code (4 Digit)</u>
1. _____	_____
2. _____	_____
3. _____	_____
4. _____	_____

C. Is your production    Batch \_\_\_\_\_    Continuous \_\_\_\_\_

- D. Is there a scheduled shutdown? Yes \_\_\_\_\_ No \_\_\_\_\_ If yes, when? \_\_\_\_\_
- E. Is production seasonal? Yes \_\_\_\_\_ No. \_\_\_\_\_ If yes, explain, indicating month(s) of peak production: \_\_\_\_\_  
 \_\_\_\_\_
- F. Total number of employees working on premises: \_\_\_\_\_
- G. Average number of employees per shift: 1<sup>st</sup> \_\_\_\_\_ 2<sup>nd</sup> \_\_\_\_\_ 3<sup>rd</sup> \_\_\_\_\_
- H. Shifts normally worked each day:
- |                 | <u>Sun.</u> | <u>Mon.</u> | <u>Tues.</u> | <u>Wed.</u> | <u>Thur.</u> | <u>Fri.</u> | <u>Sat.</u> |
|-----------------|-------------|-------------|--------------|-------------|--------------|-------------|-------------|
| 1 <sup>st</sup> | _____       | _____       | _____        | _____       | _____        | _____       | _____       |
| 2 <sup>nd</sup> | _____       | _____       | _____        | _____       | _____        | _____       | _____       |
| 3 <sup>rd</sup> | _____       | _____       | _____        | _____       | _____        | _____       | _____       |

III. WATER USAGE AND DISCHARGE

A. Raw Water Sources

<u>Source</u>	<u>Check Source(s)</u>	<u>Quantity Per Year</u>	<u>Account #</u>
Erie County Water Authority	_____	_____	_____
Well Water	_____	_____	_____
Other	_____	_____	_____

- B. Are any liquid wastes other than sanitary waste (i.e., sinks, showers, toilets) discharged from the premises? Yes \_\_\_\_\_ No. \_\_\_\_\_  
 If the answer is No, proceed to Question III G.  
 If the answer is Yes, answer Questions III C, D, E and F.

C. Check water uses in the plant

	<u>Yes</u>	<u>No</u>	<u>Gal/Day</u>
Cooling Water	_____	_____	_____
Boiler Feed	_____	_____	_____
Water Used in Process(es)	_____	_____	_____
Is water contained in the Product	_____	_____	_____
Other _____	_____	_____	_____

D. What other than sanitary waste is discharged from the premises?

<u>Check (X) applicable Items(s)</u>	<u>Discharge to:</u>
_____ Cooling Water	_____
_____ Boiler Blow Down	_____
_____ Water Used in the Process(es)	_____
_____ Other _____	_____

- E. Provide a site plan of the premises indicating all points of discharge and label type of discharge. Show where connection is made to sanitary sewers, storm sewer, surface (ditches, creeks, etc.) if known.

- F. Is your non-sanitary discharge intermittent \_\_\_\_\_ or steady \_\_\_\_\_

- G. Is your facility permitted to discharge liquid wastes under a State (S.P.D.E.S.) permit?  
 Yes \_\_\_ No \_\_\_\_\_ Permit No. \_\_\_\_\_





**TABLE I**  
**SUBSTANCE OF CONCERN**

Class A – Halogenated Hydrocarbons

- A01. Methyl chloride
- A02. Methylene chloride
- A03. Chloroform
- A04. Carbon tetrachloride
- A05. Frenon/Genatron
- A06. Other halomethanes
- A07. 1,1,1-Trichlorethane
- A08. Other haloethanes
- A09. Vinyl fluoride
- A10. Vinyl chloride
- A11. Dichlorethylene
- A12. Trichloroethylene
- A13. Tetrachloroethylene
- A14. Chlorinated propane
- A15. Chlorinated propene
- A16. Hexachlorobutadiene
- A17. Hexachlorocyclopentadiene
- A18. Chlorinated benzene
- A19. Chlorinated toluene
- A20. Fluorinated toluene
- A21. Polychlorinated biphenyl (PCB)
- A22. Chlorinated naphthalene
- A23. Dechloran (C<sub>10</sub>C<sub>12</sub>)
- A99. Halogenated hydrocarbons not Specified above

Class B – Halogenated Organics  
(Other Than Hydrocarbons)

- not specified above
- B01. Phosgene
  - B02. Methyl chloromethyl ether
  - B03. Bis-chloromethyl ether
  - B04. Other chloroalkyl ethers
  - B05. Benzoyl chloride
  - B06. Chlorothymol
  - B07. Chlorinated phenol
  - B08. Chlorinated cresols or xylenols
  - B09. Chloroacetic acid
  - B10. Chloroaryl ethers
  - B11. Dichlorophene or hexachlorophene
  - B12. Chlorinated aniline (including methylene bis (2-chloroaniline))
  - B13. Dichlorobenzidine
  - B14. Chlorinated diphenyl oxide
  - B15. Chlorinated toluidine
  - B16. Kepone (C<sub>10</sub>C<sub>10</sub><sup>0</sup>)
  - B17. Dichlorovinyl sulfonyl pyridine
  - B18. Chloropicrin
  - B20. Trichloro-propylsulfonyl pyridine
  - B21. Tetrachloro-methylsulfonyl pyridine
  - B22. Tetrachloro-isophthalonitrile
  - B99. Halogenated organics not specified

Class C – Pesticides (Including herbicides, algacides, biocides, slimicides and mildewcides)

- C01. Aldrin/Dieldrin
- C02. Chlordane & metabolites
- C03. DDT and metabolites
- C04. Endosulfan/Thiodan and Metabolites
- C05. Endrin and Metabolites
- C06. Heptachlor and Metabolites
- C07. Malathion
- C08. Methoxychlor
- C09. Parathion
- C10. Toxaphene
- C11. Sevin
- C12. Kelthane
- C13. Diazinon
- C15. Carbaryl
- C16. Silvex
- C17. Dithiocarbamates
- C18. Maneb
- C19. Dioxathion
- C20. Tandex/Karutilate
- C21. Carbofurans
- C22. Pentac
- C23. Folpet
- C24. Dichlone
- C25. Rotenone
- C26. Lindane/Isotox
- C27. Simazine
- C28. Methoprene
- C99. Pesticides not specified above
- F99. Substituted aromatics

Class D – Aromatic Hydrocarbons

- D01. Benzene
- D02. Toluene
- D03. Xylene
- D04. Biphenyl
- D05. Naphthalene
- D06. Ethylbenzene
- D07. Styrene
- D08. Acenaphthene
- D09. Fluoranthene
- D99. Aromatic hydrocarbons not specified above

Class E – Tars

- E01. Coal tar
- E02. Petroleum tar

Class M – Metals and Their Compounds

- |                |               |               |                                 |
|----------------|---------------|---------------|---------------------------------|
| M01. Antimony  | M05. Chromium | M09. Nickel   | M13. Zinc                       |
| M02. Arsenic   | M06. Copper   | M10. Selenium | M14. Boron                      |
| M03. Beryllium | M07. Lead     | M11. Silver   | M15. Manganese                  |
| M04. Cadmium   | M08. Mercury  | M12. Thallium | M99. Metals not specified above |

Class F – Substituted Aromatic (other than hydrocarbons and nonhalogenated)

- F01. Phenol, cresol, or xyleneol
- F02. Catechol, resorcinol, or hydroquinone
- F03. Nitrophenols
- F04. Nitrobenzenes
- F05. Nitrotoluenes
- F06. Aniline
- F07. Toluidines
- F08. Nitroanilines
- F09. Nitroanisole
- F10. Toluene disorionate
- F11. Dimethylaminoazobenzene
- F12. Benzoic Acid (and Benzoate salts)
- F13. Phthalic, isophthalic or terephthalic acid
- F14. Phthalic anhydride
- F15. Phthalate Esters
- F16. Phenoxyacetic acid
- F17. Phenylphenols
- F18. Nitrobiphenyls
- F19. Aminobiphenyls
- F20. Diphenylhydrazine
- F21. Naphthylamines
- F22. Carbazole
- F23. Acetylaminofluorene
- F24. Dyes and organic pigments
- F25. Pyridine

Class G - Miscellaneous

- G01. Asbestos
- G02. Acrolein
- G03. Acrylonitrile
- G04. Isophorone
- G05. Nitrosamines
- G06. Ethyleneimine
- G07. Propiolactone
- G08. Nitrosodimethylamine
- G09. Dimethyl hydrazine
- G10. Maleic anhydride
- G11. Methylisocyanate
- G12. Epoxides
- G13. Nitrofurans
- G14. Cyanide

TABLE I  
SUBSTANCE OF CONCERN (continued)

Class H - PFAS Analytes

- H01. Perfluorobutanesulfonic acid
- H02. Perfluoropentanesulfonic acid
- H03. Perfluorohexanesulfonic acid
- H04. Perfluoroheptanesulfonic acid
- H05. Perfluorooctanesulfonic acid
- H06. Perfluorononanesulfonic acid
- H07. Perfluorodecanesulfonic acid
- H08. Perfluorododecanesulfonic acid
- H09. Perfluorobutanoic acid
- H10. Perfluoropentanoic acid
- H11. Perfluorohexanoic acid
- H12. Perfluoroheptanoic acid
- H13. Perfluorooctanoic acid
- H14. Perfluorononanoic acid
- H15. Perfluorodecanoic acid
- H16. Perfluoroundecanoic acid
- H17. Perfluorododecanoic acid
- H18. Perfluorotridecanoic acid
- H19. Perfluorotetradecanoic acid
- H20. Hexafluoropropylene oxide dimer acid
- H21. 4,8-Dioxa-3H-perfluorononanoic acid
- H22. Perfluoro-3-methoxypropanoic acid
- H23. Perfluoro-4-methoxybutanoic acid
- H24. Nonafluoro-3,6-dioxaheptanoic acid
- H25. 4:2 Fluorotelomer sulfonic acid
- H26. 6:2 Fluorotelomer sulfonic acid
- H27. 8:2 Fluorotelomer sulfonic acid
- H28. 3:3 Fluorotelomer carboxylic acid
- H29. 5:3 Fluorotelomer carboxylic acid
- H30. 7:3 Fluorotelomer carboxylic acid
- H31. Perfluorooctane sulfonamide
- H32. N-methylperfluorooctane sulfonamide
- H33. N-ethylperfluorooctane sulfonamide
- H34. N-methylperfluorooctane sulfonamidoacetic acid
- H35. N-ethylperfluorooctane sulfonamidoacetic acid
- H36. N-methylperfluorooctane sulfonamidoethanol
- H37. N-ethylperfluorooctane sulfonamidoethanol
- H38. 9-Chlorohexadecafluoro-3-oxanonane-1-sulfonic acid (F-53B Major)
- H39. 11-Chloroeicosafluoro-3-oxaundecane-1-sulfonic acid (F-53B Minor)
- H40. Perfluoro(2-ethoxyethane) sulfonic acid
- H41. 1,4-Dioxane

TABLE I  
SUBSTANCE OF CONCERN (continued)

Class M – Metals and Their Compounds

- M01. Antimony
- M02. Arsenic
- M03. Beryllium
- M04. Cadmium
- M05. Chromium
- M06. Copper
- M07. Lead
- M08. Mercury
- M09. Nickel
- M10. Selenium
- M11. Silver
- M12. Thallium
- M13. Zinc
- M14. Boron
- M15. Manganese
- M99. Metals not specified

B. If you use chemical of unknown composition, list trade name or other identification, name of supplier and complete information.

Name of Substance	Class	Average Annual Usage	Amount Now on Hand	Supplier	Purpose of Use (State whether produced, reacted, blended, package, distributed, no longer used, etc.)

V. MISCELLANEOUS OPERATIONAL DATA

- A. Is this facility subject to Categorical Pretreatment Standard? (Leave blank if you do not know).  
 Yes \_\_\_ No \_\_\_
- B. Does your facility pretreat any wastewater prior to discharge to a sanitary sewer?  
 Yes \_\_\_ No \_\_\_
- C. Is there a Hazardous Waste Management Plan in effect for this plant?  
 Yes \_\_\_ No \_\_\_
- D. Is there a Spill Prevention Control and Countermeasure Plan in effect for this plant?  
 Yes \_\_\_ No \_\_\_
- E. Do you generate any liquid or solid waste such as solvents, electroplating sludges, thinners, oils, still bottoms, fly ash, filler, etc.  
 Yes \_\_\_ No \_\_\_

If yes, please fill out the following table.

Type of Waste	If this Waste is Produced by Pre-Treatment Check Here	Amount per Year (Specify lbs, tons, or gals)	Method of Disposal (Check one and Describe Below)				
			On-site	Municipal Landfill	Hazardous Waste Hauler	Reclaimed or Reused	Other

F. Hazardous Waste Hauler – Please give name and address \_\_\_\_\_

G. Reclaimed or Reused – Please describe process, if on-site, or give name and address of \_\_\_\_\_

reclaimer \_\_\_\_\_

H. Do you store any hazardous wastes on-site? Yes \_\_\_\_\_ No \_\_\_\_\_

I. Have you filed on EPA Form 8700-12 (Notification of Hazardous Waste Activity)?

Yes \_\_\_\_\_ No \_\_\_\_\_

If yes, please attach.

J. What is your Hazardous Waste Number? \_\_\_\_\_

K. Do you perform any process painting on site? Yes \_\_\_\_\_ No \_\_\_\_\_ If yes, please provide a brief description:

\_\_\_\_\_  
\_\_\_\_\_

L. Do you perform any surface preparation of materials prior to painting? Yes \_\_\_\_\_ No \_\_\_\_\_  
If yes, please describe preparation:

\_\_\_\_\_  
\_\_\_\_\_

M. Are you aware of any known sources of PFAS (per-and polyfluoroalkyl substances) or 1,4-Dioxane being used at your business? Yes \_\_\_\_\_ No \_\_\_\_\_

If so, specify the course, how is it stored and is it discharged to the sewer system?

\_\_\_\_\_  
\_\_\_\_\_

MAS:LAS:mas  
January 2, 2024

V:\DSM\Administration\FORMS\IWS-FOG\forms

**G – 2 BUFFALO SEWER AUTHORITY**

**BUFFALO SEWER AUTHORITY**  
**B.P.D.E.S. DISCHARGE PERMIT APPLICATION**

FOR BSA USE ONLY DATE APPLICATION REC'D: _____ INDUSTRIAL NUMBER: _____ INVESTIGATOR: _____
--

**PART A - GENERAL INFORMATION**

A1. Applicant Business Name \_\_\_\_\_

A2. Address of premises discharging wastewater:

\_\_\_\_\_

Street                      City                                      State                                      Zip

A3a. Business Address (if different than above):

\_\_\_\_\_

Street                                      City                                      State                                      Zip

b. Mailing Address (if different than above):

\_\_\_\_\_

Street                                      City                                      State                                      Zip

A4. Chief Business Official:

Name: \_\_\_\_\_ Title: \_\_\_\_\_

A5. Facility Representative:

Name: \_\_\_\_\_ Title: \_\_\_\_\_ Phone: \_\_\_\_\_

Fax: \_\_\_\_\_ Cell Phone: \_\_\_\_\_

E-mail address \_\_\_\_\_

A6. Person to be contacted about this application, if different from above:



Name: \_\_\_\_\_ Title: \_\_\_\_\_ Phone: \_\_\_\_\_

A7. Person to be contacted in case of emergency, if different from above:

Name: \_\_\_\_\_ Day Phone: \_\_\_\_\_ Night Phone: \_\_\_\_\_

A8. Confidentiality:

Please indicate those sections of this questionnaire that you wish to remain confidential and your basis for requesting confidentiality.

\_\_\_\_\_  
\_\_\_\_\_

I have personally examined and am familiar with the information submitted in this document and attachments. Based upon my inquiry of those individuals immediately responsible for obtaining the information reported herein, I believe that the submitted information is true, accurate and complete. I am aware that there are significant penalties for submitting false information.

\_\_\_\_\_  
Date

\_\_\_\_\_  
Signature of Official (Seal if Applicable)

PART B - BUSINESS DESCRIPTION

**PURPOSE** The business description is primarily used to determine the substances which may enter into the wastewater discharge from the business activity.

B1. Brief Description: \_\_\_\_\_  
 \_\_\_\_\_  
 \_\_\_\_\_

B2. Business Activity: North American Industry Classification System (NAICS) Codes for Principal Products or Services:

<u>Activity</u>	<u>NAICS Code (5-6 Digits)</u>	<u>Production (Monthly Avg.)*</u>
_____	_____	_____
_____	_____	_____
_____	_____	_____
_____	_____	_____

B3. Is there a scheduled shutdown? Yes \_\_\_\_\_ No \_\_\_\_\_ If yes, when? \_\_\_\_\_

B4. Is production seasonal? Yes \_\_\_\_\_ No \_\_\_\_\_ If yes, explain, indicating month(s) of peak production:  
 \_\_\_\_\_  
 \_\_\_\_\_

B5. Average number of employees per shift: 1st \_\_\_\_\_ 2nd \_\_\_\_\_ 3rd \_\_\_\_\_

Shift start times: 1st \_\_\_\_\_ 2nd \_\_\_\_\_ 3rd \_\_\_\_\_

Shift end times: 1st \_\_\_\_\_ 2nd \_\_\_\_\_ 3rd \_\_\_\_\_

Shifts normally worked each day:

	<u>Sun.</u>	<u>Mon.</u>	<u>Tue.</u>	<u>Wed.</u>	<u>Thu.</u>	<u>Fri.</u>	<u>Sat.</u>
1st	_____	_____	_____	_____	_____	_____	_____
2nd	_____	_____	_____	_____	_____	_____	_____
3rd	_____	_____	_____	_____	_____	_____	_____

\* Monthly average stated shall be the highest monthly average production in the previous three years.

PART C - WATER SOURCE AND USE

**PURPOSE** - The Water Source and Use information will enable BSA to determine the Volumes and Sources of wastewater discharged to the BSA sewer.

**WATER/WASTEWATER DATA**

C1.	Water Sources	Average Volume <u>(Gallons per Day)</u>	Peak Flow & Estimated Duration <u>(Gallons per Minute &amp; Time)</u> Recycled
	Municipal System	_____	_____
	Private Wells	_____	_____
	Other (Specify) _____	_____	_____
	Water Account No.(s)	_____	_____

C2.	Water Usage	Average Volume <u>(Gallons per Day)</u>	Peak Flow & Estimated Duration <u>(Gallons per Minute &amp; Time)</u>
	Cooling Water	_____	_____
	Boiler Makeup	_____	_____
	Process Water	_____	_____
	Sanitary Purposes	_____	_____
	Other (Specify) _____	_____	_____

C3.	Waste Water Discharge	Average Discharge <u>(Gallons per Day)</u>	Peak Discharge & Estimated Duration <u>(Gallons per Minute &amp; Time)</u>
	Municipal Sewer/Sanitary		
	- Process	_____	_____
	- Sanitary:	_____	_____
	- Cooling	_____	_____

Non-Sewered Discharges

- Natural Receiving Water \_\_\_\_\_
- Storm Drain \_\_\_\_\_
- Waste Hauler \_\_\_\_\_
- Evaporation \_\_\_\_\_
- Contained in Product \_\_\_\_\_
- Recycled \_\_\_\_\_
- Other (Specify) \_\_\_\_\_

C4. Is your facility permitted to discharge liquid wastes under a State (S.P.D.E.S.) Permit?

Yes \_\_\_\_\_ No \_\_\_\_\_ Permit No. \_\_\_\_\_

C5. Does your facility have a wastewater discharge from any air pollution control equipment?

Yes \_\_\_\_\_ No \_\_\_\_\_ If so what discharge point \_\_\_\_\_

PART D - SUBSTANCES OF CONCERN  
(REFER TO ATTACHED TABLE I)

Complete all information for those substances your facility has used, produced, stored, distributed, listed under the TRI report or otherwise disposed of since last application. Do not include chemicals used only in analytical laboratory work. Enter the name and code from Table I. If facility uses a substance in any of the Classes A-M which is not specified in the list, enter it as code class plus 99, e.g. B99 with name, usage, etc.

NAME OF SUBSTANCE	CLASS	AVERAGE ANNUAL USAGE	AMOUNT NOW ON HAND	PURPOSE OF USE (STATE WHETHER PRODUCED, REACTED BLENDED PACKAGED, DISTRIBUTED, NO LONGER USED)

TABLE 1 - SUBSTANCES OF CONCERN

**CLASS A - HALOGENATED HYDROCARBONS  
AROMATICS**

A01. Methyl chloride  
 A02. Methylene chloride  
 A03. Chloroform  
 A04. Carbon tetrachloride  
 A05. Freon/Genatron  
 A06. Other halomethanes  
 A07. 1, 1, 1-Trichlorethane  
 A08. Other haloethanes  
 A09. Vinyl fluoride  
 A10. Vinyl chloride  
 A11. Dichlorethylene  
 A12. Trichloroethylene  
 A13. Tetrachloroethylene  
 A14. Chlorinated propane  
 A15. Chlorinated propene  
 A16. Hexachlorobutadiene  
 A17. Hexachlorocyclopentadiene  
 A18. Chlorinated benzene  
 A19. Chlorinated toluene  
 A20. Fluorinated toluene  
 A21. Polychlorinated biphenyl (PCB)  
 A22. Chlorinated naphthalene  
 A23. Dechlorane (C<sub>10</sub>C<sub>12</sub>)  
 A99. Halogenated hydrocarbons not specified above

**CLASS D - AROMATIC HYDROCARBONS**

D01. Benzene  
 D02. Toluene  
 D03. Xylene  
 D04. Biphenyl  
 D05. Naphthalene  
 D06. Ethylbenzene  
 D07. Styrene  
 D08. Acenaphthene  
 D09. Fluranthene  
 D99. Aromatic hydrocarbons not specified above

**CLASS E - TARS**

E01. Coal tar  
 E02. Petroleum tar

**CLASS B - HALOGENATED ORGANICS**

(other than hydrocarbons)

B01. Phosgene  
 B02. Methyl Chloromethyl ether  
 B03. bis-chloromethyl ether  
 B04. Other chloroalkyl ethers  
 B05. Benzoyl chloride  
 B06. Chlorothymol  
 B07. Chlorinated phenol  
 B08. Chlorinated cresols or xylenols  
 B09. Chlorendic acid  
 B10. Chloraryl ethers  
 B11. Dichlorophene or hexachlorophene  
 B12. Chlorinated aniline (including methylene bis (2-chloroaniline))  
 B13. Dichlorobenzidine  
 B14. Chlorinated diphenyl oxide  
 B15. Chlorinated toluidine  
 B16. Kepone  
 B17. Dichlorovinyl sulfonyl pyridine  
 B18. Chloropicrin  
 B20. Trichloro-propylsulfonyl pyridine  
 B21. Tetrachloro-methylsulfonyl pyridine  
 B22. Tetrachloro-isophthalonitrile  
 B99. Halogenated organics not specified above

**CLASS G - MISCELLANEOUS**

G01. Asbestos  
 G02. Acrolein  
 G03. Acrylonitrile  
 G04. Isophorone  
 G05. Nitrosamines  
 G06. Ethyleneimine  
 G07. Propiolacetone  
 G08. Nitrosodimethylamine  
 G09. Dimethyl hydrazine  
 G10. Maleic anhydride  
 G11. Methyl isocyanate  
 G12. Expoxides  
 G13. Nitrofurans  
 G14. Cyanide

**CLASS C - PESTICIDES** (including

herbicides algaecides, biocides, slimicides and mildewcides)

C01. Aldrin/Dieldrin  
 C02. Chlordane and metabolites  
 C03. DDT and metabolites  
 C04. Endosulfan/Thiodan and metabolites  
 C05. Endrin and metabolites  
 C06. Heptachlor and metabolites  
 C07. Malathion  
 C08. Methoxychlor  
 C09. Parathion  
 C10. Toxaphene  
 C11. Sevin  
 C12. Kelthane  
 C13. Diazinon  
 C15. Carbaryl  
 C16. Silvex  
 C17. Dithiocarbamates  
 C18. Maneb  
 C19. Dioxathion  
 C20. Tandex/Karbutilate  
 C21. Carbofurans  
 C22. Pentac  
 C23. Folpet  
 C24. Dichlone  
 C25. Rotenone  
 C26. Lindane/Isotox  
 C27. Simazine  
 C28. Methoprene  
 C99. Pesticides not specified above

**CLASS M - METALS AND THEIR COMPOUNDS**

M01. Antimony  
 M02. Arsenic  
 M03. Beryllium  
 M04. Cadmium  
 M05. Chromium  
 M06. Copper  
 M07. Lead  
 M08. Mercury  
 M09. Nickel  
 M10. Selenium  
 M11. Silver  
 M12. Thallium  
 M13. Zinc  
 M14. Boron  
 M15. Manganese  
 M18. Titanium  
 M21. Tungster  
 M22. Gold  
 M83. Pladium  
 M84. Platinum  
 M99. Metals not specified

**CLASS F - SUBSTITUTE**

(other than hydrocarbons and non-halogenated)

F01. Phenol, cresol, or xylenol  
 F02. Catechol, resorcinol, or hydroquinone  
 F03. Nitrophenols  
 F04. Nitrobenzenes  
 F05. Nitrotoluenes  
 F06. Aniline  
 F07. Toluidines  
 F08. Nitroanilines  
 F09. Nitroanisole  
 F10. Toluene diisocyanate  
 F11. Dimethylaminoazobenzene  
 F12. Benzoic Acid (and Benzoate salts)  
 F13. Phthalic, isophthalic or terephthalic acid  
 F14. Phthalic anhydride  
 F15. Phthalate esters  
 F16. Phenoxyacetic acid  
 F17. Phenylphenols  
 F18. Nitrobiphenyls  
 F19. Aminobiphenyls (including benzidine)  
 F20. Diphenylhydrazine  
 F21. Naphthylamines  
 F22. Carbazole  
 F23. Acetylaminofluorene  
 F24. Dyes and organic pigments  
 F25. Pyridine  
 F99. Substituted aromatics not specified above

If you use chemicals of unknown composition, list trade name or other identification, name of supplier and complete information.

NAME	AVERAGE ANNUAL USAGE	AMOUNT NOW ON HAND	SUPPLIER	PURPOSE OF USE (STATE WHETHER PRODUCED, REACTED, BLENDED, PACKAGED, DISTRUBUTED, NO LONGER USED)

Are you presently permitted to discharge radiological waste by the N.Y.S.D.E.C.? Yes \_\_\_ No \_\_\_

PART E - MISCELLANEOUS

E1. Do you have automatic sampling equipment or continuous wastewater flow metering equipment currently in use or included in future plans?

Current: Flow Metering Yes \_\_\_ No \_\_\_ Sampling Equipment Yes \_\_\_ No \_\_\_  
 Planned: Flow Metering Yes \_\_\_ No \_\_\_ Sampling Equipment Yes \_\_\_ No \_\_\_

E2. Does your facility pretreat any wastewater prior to discharge to a sanitary sewer? Yes \_\_\_ No \_\_\_

\_\_\_\_\_ If so, please  
 show locations of pretreatment processes on attached schematic process diagram (Part F) and  
 describe below:

\_\_\_\_\_  
 \_\_\_\_\_  
 \_\_\_\_\_

E3. Do you have a Spill Prevention, Containment and Control Plan (SPCC) and/or Slug Discharge Control Plan for your plant? Yes \_\_\_ No \_\_\_

E4. Do you have a Solvent Management Plan or a Toxic Organic Management Plan? Yes \_\_\_ No \_\_\_

E5. Do you generate any liquid or solid waste such as solvents, electroplating sludges, thinners, oils, still bottoms, fly ash, filler, etc? Yes \_\_\_ No \_\_\_. If yes, please fill out the following table:

TYPE OF WASTE	IF THIS WASTE IS PRODUCED BY PRETREATMENT CHECK HERE	AMOUNT PER YEAR (SPECIFY LBS, TONS OR GALS)	METHOD OF DISPOSAL <u>CHECK EACH METHOD USED</u>				
			ON-SITE	SANITARY LANDFILL	HAZARDOUS WASTE FACILITY	RECLAIMED OR RESUED	OTHER

E6. Description of Disposal Method:

a. Disposal Site

\_\_\_\_\_

b. Hazardous Waste Hauler - Please give name and address \_\_\_\_\_

\_\_\_\_\_

c. Reclaimed or Reused - Please describe process, if on-site, or give name and address of reclaimer

\_\_\_\_\_

\_\_\_\_\_

d. Other - Please describe \_\_\_\_\_

\_\_\_\_\_

E7. Do you store any hazardous wastes on-site? Yes \_\_\_ No \_\_\_

E8. Have you filed an EPA Form 8700-12 (Notification of Hazardous Waste Activity)? Yes  
 \_\_\_\_\_ No \_\_\_ If yes,  
 please attach.

E9. What is your Hazardous Waste Number? \_\_\_\_\_

E10. Do you discharge into the Buffalo Sewer Authority a waste identified by 40 CFR 261 as hazardous waste?  
 Yes \_\_\_ No \_\_\_

E11. If your facility is discharging a hazardous waste, have you properly notified the Buffalo Sewer Authority?  
 Yes \_\_\_ No \_\_\_

## PART F - SCHEMATIC FLOW DIAGRAM

**PURPOSE** - The Schematic Flow Diagram shows the flow pattern of products through the facility and the various sources of wastewater.

**F1. Schematic Flow Diagram** - For each major activity in which wastewater is generated, draw a diagram of the flow of materials and water from start to completed project, showing all unit processes generating wastewater. Number each unit process having wastewater discharges to the community sewer.

**F2. General Instructions** - Type or print the information. A line drawing (schematic flow diagram) of each major business activity described in Part B is to be drawn in on an attached sheet of paper (all sheets should be letter size). An example of drawing required is shown in Figure 1. To determine your average daily volume and maximum daily volume of wastewater flow you may have to read water meters, sewer meters, or make estimates of volumes that are not directly measurable.

FILE:L/WPDOCS/APPLICATIONS/BPDESPERMITAPPLICAITON.DOC

REVISED 3/19/93, 8/30/94, 12/1/94, 10/7/96, 10/25/98, 5/1/05



DO NOT RETURN THIS PAGE WITH APPLICATION

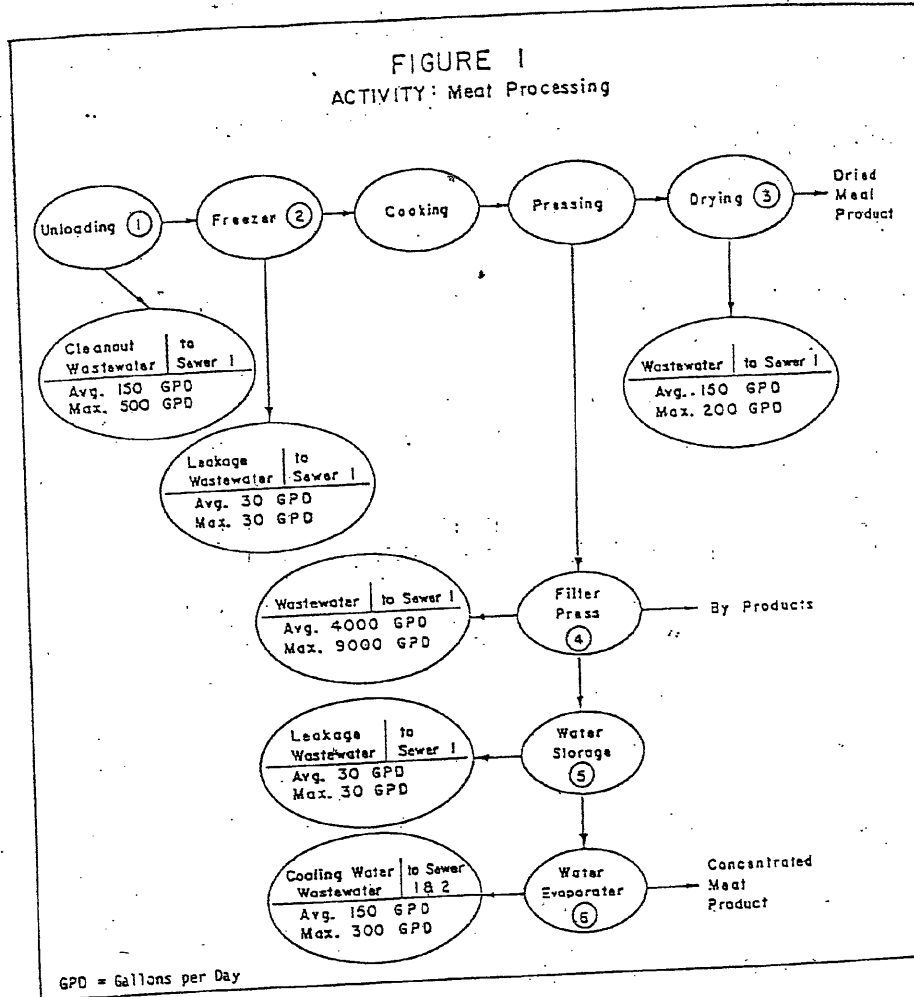

**DO NOT RETURN THIS PAGE WITH APPLICATION**

**PART G - BUILDING LAYOUT**

**PURPOSE** - The building layout shows the wastewater generating operations which contribute to each side sewer.

**INSTRUCTIONS FOR COMPLETING PART G:** General Instructions - Type or print the information.

**Building Layout** - A building layout or plant site plan of the premise is required to complete Part G. An arrow showing north as well as the map scale must be shown. The location of each existing and proposed sampling manhole and side sewer must be clearly identified, including distances as well as all sanitary and wastewater drainage plumbing. Number each unit process discharging wastewater to the community sewer. Use the same numbering system shown in Part F (Schematic Flow Diagram). An example of the drawing required is shown below in Figure 2.

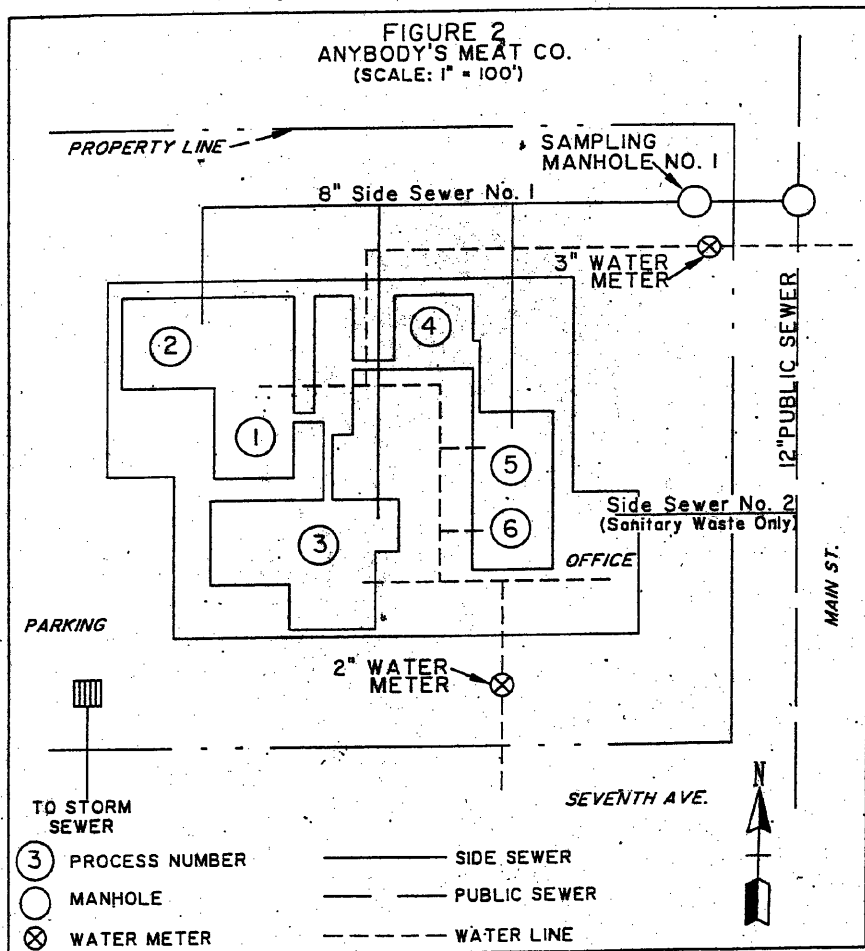

## **G – 3 AMHERST WWTP**

**For Town Use Only**

Date Application Received: \_\_\_\_\_  
Industrial No.: \_\_\_\_\_  
Inspector: \_\_\_\_\_

ECSD No. 5/TOWN OF AMHERST INDUSTRIAL WASTEWATER DISCHARGE PERMIT APPLICATION

**Part A – General Information**

A1. Applicant Business Name:

\_\_\_\_\_

A2. Address of Premises Discharging Wastewater:

\_\_\_\_\_

A3.a. Business Address (If Different Than Above):

\_\_\_\_\_

b. Mailing Address (If Different Than Above):

\_\_\_\_\_

A4. Chief Business Official:

Name: \_\_\_\_\_ Title: \_\_\_\_\_

Mailing Address: \_\_\_\_\_

A5. Person to Be Contacted About This Application:

Name: \_\_\_\_\_ Title: \_\_\_\_\_ Phone: \_\_\_\_\_

A6. Person to Be Contacted In Case Of Emergency:

Name: \_\_\_\_\_ Title: \_\_\_\_\_ Phone: \_\_\_\_\_

A7. Confidentiality:

Please indicate those sections of this questionnaire that you wish to remain confidential and your basis for requesting confidentiality.

\_\_\_\_\_

\_\_\_\_\_

\_\_\_\_\_

I have personally examined and am familiar with the information submitted in this document and attachments. Based upon my inquiry of those individuals immediately responsible for obtaining the

information reported herein, I believe that the submitted information is true, accurate and complete. I am aware that there are significant penalties for submitting false information.

---

Date

Signature of Responsible Official (Seal if Applicable)

PART B – BUSINESS  
DESCRIPTION

Purpose – The business description is primarily used to determine the substance, which may enter into the wastewater discharge from the business activity.

B.1 Brief Description: \_\_\_\_\_  
\_\_\_\_\_  
\_\_\_\_\_

B2. Business Activity: Standard Industrial Classification (SIC) Codes for Principle Products or Services:

Activity	SIC Code (4 Digits)	Production (Monthly Average)*

B3. Is there a scheduled shutdown? Yes: \_\_\_ No: \_  
If yes, when?: \_\_\_\_\_

B4: Is production seasonal? Yes: \_\_\_\_\_ No: \_\_\_\_\_  
If yes, explain, indicating month(s) of peak production: \_\_\_\_\_  
\_\_\_\_\_  
\_\_\_\_\_

B5. Average number of employees per shift: 1<sup>st</sup> \_\_\_\_\_ 2<sup>nd</sup> \_\_\_\_\_ 3<sup>rd</sup> \_\_\_\_\_  
Shift start times: 1<sup>st</sup> \_\_\_\_\_ 2<sup>nd</sup> \_\_\_\_\_ 3<sup>rd</sup> \_\_\_\_\_  
Shift end times: 1<sup>st</sup> \_\_\_\_\_ 2<sup>nd</sup> \_\_\_\_\_ 3<sup>rd</sup> \_\_\_\_\_

Shifts normally worked each day:

	Sunday	Monday	Tuesday	Wednesday	Thursday	Friday	Saturday
1 <sup>st</sup>							
2 <sup>nd</sup>							
3 <sup>rd</sup>							

\* Monthly average stated shall be the highest monthly average production in the previous five years.

PART C – WATER  
SOURCE AND USE

Purpose – The water source and use information will enable the Town of Amherst to determine the volume and sources of wastewater discharged to the Town of Amherst Sewerage System.

C1. Water Sources	Average Volume (Gallons Per Day)	Peak Flow/Estimated Duration (Gallons Per Minute)
Water Authority		
Recycled		
Private Wells		
Other (Specify)		
Water Account Number(s)		

C2. Water Usage	Average Volume (Gallons Per Day)	Peak Flow/Estimated Duration (Gallons Per Minute)
Cooling Water		
Boiler Makeup		
Process Water		
Sanitary Purposes		
Other (Specify)		

C3. Wastewater Usage	Average Volume (Gallons Per Day)	Peak Flow/Estimated Duration (Gallons Per Minute)
Process		
Sanitary		
Cooling		

Non-Sanitary Sewer Discharges

Natural Receiving Water	
Storm Drain	
Waste Hauler	
Evaporation	
Contained in Product	
Recycled	
Other (Specify)	

C4: Is your facility permitted to discharge liquid waste under a (S.P.D.E.S.) Permit?

Yes: \_\_\_\_\_ No: \_\_\_\_\_ Permit No.: \_\_\_\_\_

C5. Does your facility have wastewater discharge from any pollution control equipment?

Yes: \_\_\_\_\_ No: \_\_\_\_\_

PART C – WATER  
SOURCE AND USE

(Refer to Attached Table 1)

Complete all information for those substances your facility has used, produced, stored, distributed or otherwise disposed of since your last application. Do not include chemicals used only in analytical work. Enter the name and code from Table 1. If your facility uses a substance in any of the classes A-M, which is not specified in the list, enter it as Code Class 99, e.g. B99 with name, usage, etc.

Name of Substance	Class	Average Annual Usage	Amount Now on Hand	Purpose of Use (state whether produced, reacted, blended, packaged, distributed, no longer used, etc.)



**TABLE 1**  
**SUBSTANCES OF CONCERN**

Class A – HALOGENATED	C12. Kelthane	CLASS G – MISCELLANEOUS
Hydrocarbons	C13. Diazinon	
	C15. Carbaryl	G01. Asbestos
A01. Methyl Chloride	C16. Silvex	G02. Acrolein
A02. Methylene Chloride	C17. Dithiocarbamates	G03. Acrylonitrile
A03. Chloroform	C18. Maneb	G04. Isophorone
A04. Carbon Tetrachloride	C19. Dioxathion	G05. Nitrosamines
A05. Freon/Genatron	C20. Tandex/Karbutilate	G06. Ethyleneimine
A06. Other Halomethanes	C21. Carbofurans	G07. Propylolactone
A07. 1,1,1-Trichloroethane	C22. Pentac	G08. Nitrosodimethylamine
A08. Other Haloethanes	C23. Folpet	G09. Dimethyl Hydrazine
A09. Vinyl Fluoride	C24. Dichlone	G10. Maleic Anhydride
A10. Vinyl Chloride	C25. Rotenone	G11. Methyl Isocyanate
A11. Dichloroethylene	C26. Lindane/Isotox	G12. Epoxides
A12. Trichloroethylene	C27. Simazine	G13. Nitrofurans
A13. Tetrachloroethylene	C28. Methoprene	G14. Cyanide
A14. Chlorinated Propane	C99. Pesticides not specified above	
A15. Chlorinated Propene		CLASS M – METALS AND THEIR COMPOUNDS
A16. Hexachlorobutadiene	CLASS D – AROMATIC HYDROCARBONS	
A17. Hexachlorocyclopentadiene		M01. Antimony
A18. Chlorinated Benzene	D01. Benzene	M02. Arsenic
A19. Chlorinated Toluene	D02. Toluene	M03. Beryllium
A20. Fluorinated Toluene	D03. Xylene	M04. Cadmium
A21. Polychlorinated Biphenyl (PCB)	D04. Biphenyl	M05. Chromium
A22. Chlorinated Naphthalene	D05. Naphthalene	M06. Copper
A23. Dechlorene (C <sub>10</sub> Cl <sub>13</sub> )	D06. Ethylbenzene	M07. Lead
A99. Halogenated Hydrocarbons not Specified above	D07. Styrene	M08. Mercury
	D08. Acenaphthene	M09. Nickel
	D09. Fluranthene	M10. Selenium
CLASS B – Halogenated Organics (other than Hydrocarbons)	D99. Aromatic Hydrocarbons not specified above	M11. Silver
		M12. Thallium
	CLASS E – TARS	M13. Zinc
B01. Phosgene		M14. Boron
B02. Methyl Chloromethyl Ether	E01. Coal Tar	M15. Manganese
B03. Bis-Chloromethyl Ether	E02. Petroleum Tar	M18. Titanium
B04. Other Chloroalkyl Ethers		M21. Tungsten
B05. Benzoyl Chloride	CLASS F – SUBSTITUTED AROMATICS	M22. Gold
B06. Chlorothymol	(other than hydrocarbons and non-halogenated)	M83. Palladium
B08. Chlorinated Cresols or Xylenols		M84. Platinum
B10. Chlorendic Acid	F01. Phenol, Cresol, or Xylenol	M99. Metals not specified above
B11. Dichlorophene or Hexachlorophene	F02. Catechol, Resorcinol, or Hydroquinone	
B12. Chlorinated Aniline (including Methylene bis (2-chloroaniline))	F03. Nitrophenols	
	F04. Nitrobenzenes	
B13. Dichlorobenzidene	F05. Nitrotoluenes	
B14. Chlorinated Diphenyl Oxide	F06. Aniline	
B15. Chlorinated Toluidine	F07. Toluidines	
B16. Kepone (C <sub>10</sub> Cl <sub>10</sub> O)	F08. Nitroanilines	
B17. Dichlorovinyl Sulfonyl Pyridine	F09. Nitroanisole	
B18. Chloropicrin	F10. Toluene Dilsocyanate	
B20. Trichloro-propylsulfonyl Pyridine	F11. Dimethylaminoazobenzene	
B21. Tetrachloro-methylsulfonyl Pyridine	F12. Benzoic Acid (and Benzoate salts)	
B22. Tetrachloro-isophthalonitrile	F13. Phthalic, Isophthalic, Terephthalic Acid	
B99. Halogenated Organics not specified above	F14. Phthalic Anhydride	
	F15. Phthalate Esters	
CLASS C – Pesticides (including herbicides, algicides, biocides, slimicides and mildewicides)	F16. Phenoxyacetic Acid	
	F17. Phenylphenols	
	F18. Nitrobiphenyls	
C01. Aldrin/Dieldrin	F19. Aminobiphenyls (including Benzidine)	
C02. Chlordane and metabolites	F20. Diphenylhydrazine	
C03. DDT and metabolites	F21. Naphthylamines	
C04. Endosulfan/Thiodan and metabolites	F22. Carbazole	
C05. Endrin and metabolites	F23. Acetylaminofluorene	
C06. Heptachlor and metabolites	F24. Dyes and organic pigments	
C07. Malathion	F25. Pyridine	
C08. Methoxychlor	F99. Substituted aromatics not specified above	
C09. Parathion		
C10. Toxaphene		
C11. Sevin		

If you use chemicals of unknown composition, list trade names or other identification, name of supplier and complete information.

Name of Substance	Average Annual Usage	Amount Now on Hand	Supplier	Purpose of Use (State whether produced, reacted, blended, packaged, disturbed, no longer used)

**PART E**

E1. Do you have automatic sampling equipment or continuous wastewater flow metering equipment currently in use or included in future plans?

Current:      Flow Metering    Yes:\_\_\_No:\_\_\_                  Sampling Equipment    Yes:\_\_\_No:\_\_\_  
 Planned:      Flow Metering    Yes:\_\_\_No:\_\_\_                  Sampling Equipment    Yes:\_\_\_No:\_\_\_

E2. Does your facility pretreat any wastewater prior to discharge to a sanitary sewer?    Yes:\_\_\_No:\_\_\_

If yes, please show locations of pretreatment process on attached schematic process diagram (Part F) and describe below:

---



---

E3. Do you have a spill prevention, containment and control plan for your plant?                  Yes:\_\_\_No:\_\_\_

E4. Do you generate any liquid or solid wastes such as solvents, electroplating sludges, thinners, oils, still bottoms, fly ash, filler, etc.?    Yes:\_\_\_No:\_\_\_                  If yes, please fill out the following table.

Type of waste	If this waste is produced by pretreatment check here	Amount per year (specify lbs., tons, or gals.)	Onsite	Sanitary Landfill	Hazardous Waste Facility	Reclaimed or Reused	Other

E5. Description of Disposal Method

a. Disposal Site:

---

b. Hazardous Waste Hauler – Please give name and address:

---

c. Reclaimed or Reused – Please describe process, if on-site, or give name and address of reclaimer:

---

---

d. Other – Please describe:

---

---

E6. Do you store any hazardous waste on-site? Yes:\_\_\_No:\_\_\_

E7. Have you filed an EPA Form 8700-12 (Notification of Hazardous Waste Activity)? Yes:\_\_\_No:\_\_\_

E8. What is your hazardous waste number?\_\_\_\_\_

PART F – SCHEMATIC FLOW DIAGRAM

Purpose – The Schematic Flow Diagram shows the flow pattern of the products through the facility and the various sources of wastewater.

Schematic Flow Diagram – For each major activity in which wastewater is generated, draw a diagram of the flow of materials and water from the start to completed project, showing all unit processes generating wastewater. Number each unit process having wastewater discharges to the Town sewer.

General Instructions – Type or print the information. A separate PART F should be completed for each major business activity described in Part B.

A line drawing (schematic flow diagram) of each major business activity described in PART B is to be drawn in on an attached sheet of paper (all sheets should be letter size). Number each process, which generates wastewater using the same number as in the building layout or plant site plan shown in PART G.

To determine your average daily volume and maximum daily volume of wastewater flow, you may have to read water meters, sewer meters, or make estimates of volumes that are not directly measurable.

FIGURE 1  
PROCESS DIAGRAM

**ACTIVITY:** \_\_\_\_\_

## **PART G – BUILDING LAYOUT**

Purpose – The Building Layout shows the wastewater generating operations,

which contribute to each side sewer. Instructions for completing PART G:

General Instructions – Type or print the information.

Building Layout – A building layout or plant site plan of the premises is required to complete PART G. An arrow showing north as well as the map scale must be shown. The location of each existing and proposed sampling manhole and side sewer must be clearly identified, including distances as well as all sanitary and wastewater drainage plumbing. Number each unit process discharging wastewater to the Town sewer. Use the same numbering system shown in PART F (Schematic Flow Diagram).

FIGURE 2 FLOW DIAGRAM

## **APPENDIX H**

### **FORMS**

**H – 1 APPLICATION (92-19-4)**

**H – 2 PROJECT DATA (BMW-65)**

# **H – 1 APPLICATION (92-19-4)**

**NEW YORK STATE DEPARTMENT OF ENVIRONMENTAL CONSERVATION  
APPLICATION FOR APPROVAL OF PLANS FOR A WASTEWATER DISPOSAL SYSTEM**

1. NAME OF APPLICANT		2. LOCATION OF WORKS (City, Village, Town)		3. COUNTY	
4. ENTITY OR AREA SERVED		5. TYPE OF OWNERSHIP <input type="checkbox"/> Municipal <input type="checkbox"/> Industrial		<input type="checkbox"/> Commercial <input type="checkbox"/> Sewage Works Corp <input type="checkbox"/> Private - Home <input type="checkbox"/> Private - Other <input type="checkbox"/> Private - Institutional <input type="checkbox"/> Board of Education <input type="checkbox"/> Authority <input type="checkbox"/> Federal <input type="checkbox"/> State <input type="checkbox"/> Interstate <input type="checkbox"/> International <input type="checkbox"/> Indian Reservation	
6. TYPE AND NATURE OF CONSTRUCTION Collection System <input type="checkbox"/> New <input type="checkbox"/> Additions or Alterations		Treatment and/or Disposal <input type="checkbox"/> New <input type="checkbox"/> Additions or Alterations		7. ESTIMATED COST OF CONSTRUCTION Collection System \$ Treatment and/or Disposal \$	
8. TYPE OF WASTE <input type="checkbox"/> Sewage <input type="checkbox"/> Industrial (Specify) <input type="checkbox"/> Other (Specify)					
9. NAME OF RECEIVING TREATMENT WORKS		10. POINT OF DISCHARGE			
		Surface Water: (Name of Watercourse)		Class	
		Ground Water: (Name of Watercourse to which ground water is tributary)		Class	
11. IS STATE OR FEDERAL AID APPLIED FOR? <input type="checkbox"/> Yes <input type="checkbox"/> No		LOCATION (City, Village, Town)	TYPE OF PERMIT <input type="checkbox"/> NYDES <input type="checkbox"/> SPDES	PERMIT NO.	DATE ISSUED
12. NAME OF DESIGN ENGINEER				NEW YORK STATE LICENSE NO.	
ADDRESS				TELEPHONE NO.	
13. WATER CONSUMPTION (GPD) Present		Future		Design Year	
14. POPULATION SERVED Present		Future		Design Year	
15. AVERAGE DAILY FLOW FOR NEW OR EXISTING TREATMENT WORKS (GPD) Present		Future		Design Year	
16. SOURCE OF WATER SUPPLY (if private well, give location, type, depth and character of soil)		17. DESIGN EQUIVALENT POPULATION (BOD Basis)			
		Design Flow	GPD	Design Plant Efficiency	%
18. GIVE NUMBER, CHARACTER AND DISTANCE OF ANY BUILDINGS WHICH MAY BE AFFECTED BY THE PROPOSED TREATMENT WORKS			19. DESCRIBE PROPOSED OR EXISTING STORM WATER DISPOSAL		
<b>ADDITIONAL INFORMATION MUST BE SUBMITTED FOR PRIVATE AND INSTITUTIONAL SYSTEMS.</b>					
20. INDICATE OF U.S.G.S. TOPOGRAPHIC MAP EXACT LOCATION OF SEWAGE TREATMENT WORKS AND ADJACENT BUILDINGS. SHOW LOCATION OF ALL WELLS OR OTHER SOURCES OF WATER SUPPLY WITHIN 200' OF THE PROPOSED WORKS. GIVE DESCRIPTION OF THESE SOURCES AND CHARACTER OF SOIL					
21. STATE DEPTH BELOW EXISTING GROUND SURFACE AT WHICH GROUND WATER IS ENCOUNTERED			22. DESCRIBE SOIL AT SITE OF PROPOSED WORKS. GIVE DESIGN BASIS AND OBSERVED SOIL PERCOLATION RATE DATA (Use additional sheet, if necessary)		
DATE:					



**NOTE:** All applications must be accompanied by plans, specifications and completed Form BSP-65 (appropriate portions). The submission must conform to a previously approved engineering report describing the system in detail. The plans must be stamped with the designing engineer's seal and must be of sufficient clarity and eligibility to permit satisfactory microfilming. Only white prints will be accepted because of the difficulty of microfilming blue prints. There must be a blank area, at least 4" X 7", in the lower right corner of each sheet so that the approval stamp may be placed on the face of the plans.

Any deviation from the Department's standards for wastewater collection and treatment facilities must be explained in detail.

Approved plans are to be returned to:  Applicant  Engineer

If the application is signed by a person other than the applicant shown in Item 1, the application must be accompanied by a letter of authorization. Failure to comply with this provision may be grounds for the rejection of any submission.

I hereby affirm under penalty of perjury that information provided on this form is true to the best of my knowledge and belief. False statements made herein are punishable as a Class A misdemeanor pursuant to Section 210.45 of the Penal Law.

Signatures and Official Titles: \_\_\_\_\_

Mailing Address: \_\_\_\_\_

Date of Application: \_\_\_\_\_

REMARKS:

## **H – 2 PROJECT DATA (BMW-65)**

TECHNICAL REVIEW OF PLANS AND SPECIFICATIONS  
FOR SEWAGE AND WASTE TREATMENT SYSTEMS

PROJECT DATA

1. Type of Facility \_\_\_\_\_  
(Treatment plant, interceptor, pumping station, additions, etc.)
2. Location \_\_\_\_\_
3. Type of sewer system \_\_\_\_\_  
(separate or combined)
4. Population to be immediately served \_\_\_\_\_  
Design Population \_\_\_\_\_
5. Design Period \_\_\_\_\_
6. Hydraulic Loading

	Present flow (mgd)	Design flow (mgd)
Sanitary sewage	_____	_____
Institutional sewage	_____	_____
Industrial waste	_____	_____
Infiltration	_____	_____
<u>Total</u>	_____	_____
Minimum flow	_____	_____
Maximum flow	_____	_____

Engineer's Signature and Seal:

92-15-8 (5/77)  
Formerly  
BMW-65(11/73)

---

ENGINEERING REPORT - SEWER SYSTEM

Ref.	Point Under Review	Standard	This Project	Remarks
11.	Does the engineering report include a tabular form giving depths and velocities of flow at minimum, average, and maximum daily sewage flows for all sewers proposed?	yes		
	If the project is for sewer extensions only, is the engineering report prepared in accordance with section 11.1 and 11.2? The report should state:	yes		
	(1) Name and exact location of the treatment plant to which the proposed sewer extensions will be tributary.	-		
	(2) Present average daily sewage flow received by the plant.	-		
	(3) Design flow and the design year for the plant.	-		
	(4) The date when the permit for the plant was issued.	-		

OUTFALL SEWERS

Ref.	Point Under Review	Standard	This Project	Remarks
55.	Is the outfall sewer submerged?	yes		
	Is the discharge end of the outfall sewer extended into the middle of the receiving stream?	yes		
	Are diffusion facilities provided?	yes		

Remarks including explanation of departures from standard practice:



SEWER SYSTEM

Ref.*	Point Under Review	Standard	This Project	Remarks
31.	Is the proposed sewer system separate or combined?	separate		
	Does sewage overflow from proposed intercepting sewers?	no		
32.	Is sewer system designed for estimated ultimate tributary population?	yes		
33.	Are sewers sized to meet requirements of sections 32, 33.1, 33.2 and 33.3?	yes		
11.24	What average unit sewage flow (gpcd) is proposed for design?	100 gpcd		
33.1	What is maximum diameter of sewers?	8"		
33.2	Are sewers designed deep enough to drain all basements and to prevent freezing?	yes		
33.4	Will all sewers be constructed at or greater than the specified minimum gradient?	yes		
	Does the design comply with requirements stated in subsections 33.4, 33.5, 33.6, 33.7, and 33.8?	yes		
34.	Are manholes designed and specified according to Section 34?	yes		
34.3	What is minimum manhole diameter?	48"		
35.	Are inverted siphons, if any, designed in accordance with Section 35?	yes		
38.	Where water lines are close to proposed sewers, does design protect water supplies according to Section 38?	yes		

Remarks including explanation of departures from standard practice:

\* Reference numbers refer to numbers of Sections and Paragraphs of Great Lakes - Upper Mississippi River Board of State Sanitary Engineers 1990 Edition, Recommended Standards for Sewage Works.



# **APPENDIX I**

## **PUMPS AND WETWELL (PUMP CHAMBER) SIZING**

Ultimate pump capacity is shown in *Table No. 1* where the pump factor two (2) is taken from the *SWPA Handbook*. This pump factor is reduced as the peak flow of a project is increased. For projects where the peak flow is greater than 500 gpm, the design engineer should discuss in advance with the DSM the pump factor to be used. The following example is applicable for projects where the peak flow is up to 250 gpm.

$$\text{Volume (gallons)} = \text{Cycle Time (minutes)} \times \text{Ultimate Pump Capacity (gpm)}/4$$

$$\text{Volume (gallons)} = 6 \times 2 \times \text{Peak Flow}/4$$

$$\text{Volume (gallons)} = 3 \times \text{Peak Flow}$$

The wet well area (A) in square feet (SF) would be:

$$A \text{ (SF)} = 3 \times \text{Peak Flow} / (1 \text{ ft. (operating range)} \times (7.48 \text{ gal/ft}^3))$$

$$A \text{ (SF)} = 0.4 \times \text{Peak Flow}$$

Therefore, the minimum wet well diameter (D) in feet would be:

$$A \text{ (SF)} = \pi D^2 / 4 = 0.4 \times \text{peak flow}$$

$$D^2 = 4 \times 0.4 \times \text{Peak Flow} / \pi$$

$$D^2 = 0.51 \times \text{Peak Flow}$$

$$\mathbf{D = (0.51 \times \text{Peak Flow})}^{1/2}$$



Example: If the peak flow of a development is 200 gpm, then the wet well diameter would be:

$$D = (0.51 \times \text{Peak Flow})^{1/2}$$

$$= (.51 \times 200)^{1/2} = 10 \text{ feet}$$

Table No. 1 below is based on a one (1') foot operating range and the design criteria for a single-family home (3.5 people x 100 gpd x peak factor).

TABLE NO. 1

Square Wetwell (ft x ft)	Circular Wetwell Diameter (ft)	Peak Flow Single Family Home Design Criteria (gpm) (Q)	Pump Factor	Ultimate Pump Rate Required	Minimum One Pump Capacity (gpm)	Maximum # of Single Family Homes Allowed
---	6	68	2	2 X Q	136	70
---	8	121	2	2 X Q	242	125
---	10	194	2	2 X Q	388	200
10 X 10	12	243	2	2 X Q	486	250
---	12	282	1.85	1.85 X Q	522	290
12 X 12	14	360	1.7	1.70 X Q	612	370
14 X 14	16	486	1.55	1.55 X Q	753	500

Note: Both circular and square wet well dimensions are shown due to limited availability of precast circular wet wells in large sizes.

\*\*\*\*\*