



# County of Erie

DIVISION OF PURCHASE

## STANDARD AGREEMENT

This AGREEMENT, made as of the 8<sup>th</sup> DAY OF JULY, 2024

by and between VISONE CONSTRUCTION, INC.

of 79 SHELDON AVENUE, DEPEW, NY 14043

herein after referred to as the Contractor, and the County of Erie, a municipal corporation of the State of New York, hereinafter referred to as the County:

WHEREAS, in accordance with public open competitive bidding, sealed proposals were received and publicly opened by the County of Erie, Division of Purchase

on JANUARY 12, 2024 at 11:00AM

for: SANITARY SEWER OPEN CUT REPAIR

WHEREAS, the bid of the Contractor submitted in accordance therewith, the sum of \$5,381,625.00, was the second lowest responsible bid submitted; and

WHEREAS, a contract is hereby awarded, on a secondary, on-call basis, to the Contractor by the County, in accordance with the provisions therein contained; and

WHEREAS, the Notice to Bidders and Specifications make provisions for entering into a proper and suitable contract in connection therewith;

NOW, therefore, the Contractor does hereby for its heirs, executors, administrators and successors agree with the County of Erie that, the Contractor shall for the consideration mentioned, and in the manner set forth in Accepted Invitation to Bid No. 230311-002, Specifications and Provisions of Law annexed hereto and forming a part of this contract, furnish the equipment and materials and perform the work and services described in the Accepted Bid for the above sum.



\_\_\_\_\_ Paid monthly upon presentation of invoices.

\_\_\_\_\_ Upon delivery, completion and approval of the  
work, as per specifications.

Please refer to the Invitation to Bid (Page 1) and the Instructions to Bidders which are part of this agreement.

IN WITNESS THEREOF, the parties hereto have hereunto set their hands and seals the day and year first above written.

COUNTY OF ERIE

CONTRACTOR: VISONE CONSTRUCTION, INC.

by \_\_\_\_\_  
Director of Purchase

by Shirley M. Miele

Date \_\_\_\_\_

Title Secretary

Date 7/17/24

APPROVED AS TO FORM

\_\_\_\_\_  
Assistant County Attorney  
County of Erie, New York

Date \_\_\_\_\_





# COUNTY OF ERIE

DEPARTMENT OF ENVIRONMENT & PLANNING  
DIVISION OF SEWERAGE MANAGEMENT  
ERIE COUNTY SEWER DISTRICT NO.  
1,2,3,4,5,6 & 8

SPECIFICATIONS AND CONTRACT DOCUMENTS  
FOR CONSTRUCTION OF  
CONTRACT No. 96

SANITARY SEWER OPEN CUT REPAIR TERM  
CONTRACT (2024-2026)

COUNTY EXECUTIVE

MARK C. POLONCARZ

COMMISSIONER

Department of Environment & Planning

DANIEL CASTLE, AICP

DEPUTY COMMISSIONER

Division of Sewerage Management

JOSEPH L. FIEGL, P.E.

ERIE COUNTY SEWER DISTRICT NO. 1, 2, 3, 4, 5, 6, & 8

CONTRACT No. 96

SANITARY SEWER OPEN CUT REPAIR

TERM CONTRACT (2024-2026)

DECEMBER 2023

TABLE OF CONTENTS (continued)

**DIVISION 00 – BIDDING AND CONTRACTING REQUIREMENTS**

INVITATION TO BID

Invitation to Bid.....	1
EXHIBIT “G” – Non-Collusive Bidding Certification	
Bid Specifications .....	2
Instructions to Bidders (Division of Purchase) .....	3
Bidder Information.....	6
EXHIBIT “A” – Assignment of Public Contracts	
EXHIBIT “B” – Purchases by Other Local Government or Special Districts	
EXHIBIT “C” – Construction/Reconstruction Contracts	
EXHIBIT “D” – 5% Bid Bond (Formal Bid)	
EXHIBIT “EP” – Erie County Equal Pay Certification	
EXHIBIT “F” – Standard Agreement	
EXHIBIT “H” – MBE/WBE/SDVOB Commitment	
EXHIBIT “IC” – Insurance Classification “A”	
EXHIBIT “P” & EXHIBIT “PBI” – Performance Bond “100%”	
EXHIBIT “PW” – NYS Prevailing Wage	
EXHIBIT “Q” – Confined Space Certification	
EXHIBIT “V” – Vendor Federal Compliance Certification	

ADDITIONAL BIDDING REQUIREMENTS

00 21 13	Additional Instructions to Bidders .....	00 21 13-1
00 41 13	Bid Form .....	00 41 13-1

CONTRACTING REQUIREMENTS

00 72 13	General Conditions.....	00 72 13-1
00 73 01	Supplementary Conditions .....	00 73 01-1
00 73 36	Equal Employment Opportunity Requirements .....	00 73 36-1
00 73 38	Apprenticeship Requirements .....	00 73 38-1
00 73 39	Minority Business Enterprise Requirements.....	00 73 39-1
00 73 40	Disadvantaged Worker Requirements.....	00 73 40-1
00 73 43	Wage Rate Requirements .....	00 73 43-1
00 73 75	Local Agency Requirements .....	00 73 75-1

## TABLE OF CONTENTS (continued)

### SPECIFICATIONS

#### DIVISION 01 – GENERAL REQUIREMENTS

01 11 13	Work Covered by Contract Documents .....	01 11 13-1
01 14 17	Coordination with Owner's Operations .....	01 14 17-1
01 14 19	Use of Site .....	01 14 19-1
01 14 33	Work in Rights of Way .....	01 14 33-1
01 20 13	Lump Sum Measurement and Payment .....	01 20 13-1
01 21 16	Contingency Allowances.....	01 21 16-1
01 22 13	Unit Price Measurement and Payment.....	01 22 13-1
01 25 13	Product Substitution Procedures .....	01 25 13-1
01 26 10	Contract Modification Procedures.....	01 26 10-1
01 29 73	Schedule of Values.....	01 29 73-1
01 29 76	Progress Payment Procedures .....	01 29 76-1
01 31 13	Project Coordination.....	01 31 13-1
01 31 19.13	Pre-Construction Meeting .....	01 31 19.13-1
01 31 19.23	Progress Meetings .....	01 31 19.23-1
01 32 16	Construction Progress Schedule.....	01 32 16-1
01 32 33	Photographic Documentation.....	01 32 33-1
01 33 10	Submittal Procedures.....	01 33 10-1
01 35 23	Owner Safety Requirements.....	01 35 23-1
01 35 26.23	Confined Space Entry Plan .....	01 35 26.23-1
01 35 28	Contractor Health and Safety Plan.....	01 35 28-1
01 35 43.13	Environmental Procedures for Hazardous Materials.....	01 35 43.13-1
01 41 05	Regulatory Requirements .....	01 41 05-1
01 41 27	Dust Control.....	01 41 27-1
01 41 28	Stormwater Pollution Prevention.....	01 41 28-1
01 42 00	References .....	01 42 00-1
01 45 05	Quality Control .....	01 45 05-1
01 45 29	Testing Laboratory Services .....	01 45 29-1
01 45 33	Code-Required Special Inspections and Procedures .....	01 45 33-1
01 51 05	Temporary Utilities .....	01 51 05-1
01 52 16	First Aid Facilities.....	01 52 16-1
01 52 19	Sanitary Facilities.....	01 52 19-1
01 55 10	Vehicle Access and Parking .....	01 55 10-1
01 55 33	Traffic Control.....	01 55 33-1
01 57 20	Temporary Bypass Pumping .....	01 57 20-1
01 57 33	Security .....	01 57 33-1
01 61 00	Common Product Requirements .....	01 61 00-1
01 62 00	Product Options.....	01 62 00-1
01 64 00	Owner-Furnished Products.....	01 64 00-1
01 65 00	Product Delivery Requirements .....	01 65 00-1
01 66 00	Product Storage and Handling Requirements .....	01 66 00-1

## TABLE OF CONTENTS (continued)

01 71 23	Field Engineering .....	01 71 23-1
01 71 34	Protection of the Work and Property.....	01 71 34-1
01 73 19	Installation .....	01 73 19-1
01 73 24	Connections to Existing Facilities.....	01 73 24-1
01 73 29	Cutting and Patching .....	01 73 29-1
01 74 10	Cleaning and Waste Management .....	01 74 10-1
01 77 19	Closeout Requirements .....	01 77 19-1
01 77 23	Post Final Inspection.....	01 77 23-1
01 78 39	Project Record Documents.....	01 78 39-1
01 91 13	General Commissioning Requirements .....	01 91 13-1

### DIVISION 02 – EXISTING CONDITIONS

02100	Clearing and Grubbing.....	2-1
02150	Site Dewatering Systems .....	2-3
02200	Earthwork.....	2-6
02215	Utility Protection.....	2-17
02250	Temporary Sheeting, Shoring and Bracing.....	2-19
02300	Storm Sewer & Appurtenances.....	2-22
02350	Force Main Sewers .....	2-24
02375	Sanitary Sewers.....	2-30
02376	Sanitary Sewer Manholes .....	2-41
02600	Paving and Surfacing.....	2-47
02620	Curbing .....	2-52
02800	Restoration .....	2-54
02810	Sodding .....	2-63
02820	Hydroseeding.....	2-65
02900	Abandonment of Pipe and Manholes .....	2-67

### DIVISION 03 – CONCRETE

03100	Concrete Formwork .....	3-1
03200	Concrete Reinforcement .....	3-8
03300	Cast-In-Place Concrete .....	3-12
03310	Concrete – General .....	3-30

### APPENDICES

A	Standard Details
---	------------------

END OF TABLE OF CONTENTS



**County of Erie**  
 DIVISION OF PURCHASE  
NON-COLLUSIVE BIDDING CERTIFICATION

By submission of this bid, each bidder and each person signing on behalf of any bidder certifies, and in the case of a joint bid each party thereto certifies as to its own organization, under penalty of perjury, that to the best of his knowledge and belief:

(1) the prices in this bid have been arrived at independently without collusion, consultation, communication, or agreement, for the purpose of restricting competition, as to any matter relating to such prices with any other bidder or any competitor;

(2) unless otherwise required by law, the prices which have been quoted in this bid have not been knowingly disclosed by the bidder and will not knowingly be disclosed by the bidder prior to opening, directly or indirectly, to any other bidder or to any competitor; and

(3) no attempt has been made or will be made by the bidder to induce any other person, partnership or corporation to submit or not to submit a bid for the purpose of restricting competition.

**NOTICE**

(Penal Law, Section 210.45)

IT IS A CRIME, PUNISHABLE AS A CLASS A MISDEMEANOR UNDER THE LAWS OF THE STATE OF NEW YORK, FOR A PERSON, IN AND BY A WRITTEN INSTRUMENT, TO KNOWINGLY MAKE A FALSE STATEMENT, OR TO MAKE A FALSE STATEMENT, OR TO MAKE A STATEMENT WHICH SUCH PERSON DOES NOT BELIEVE TO BE TRUE.

**BID NOT ACCEPTABLE WITHOUT FOLLOWING CERTIFICATION:**

Affirmed under penalty of perjury this 11<sup>th</sup> day of January, 20 24

TERMS HAND DELIVERY DATE AT DESTINATION 95 Franklin St. Buffalo, NY

FIRM NAME Visona Construction, Inc

ADDRESS 79 Sheldon Ave

Depew NY ZIP 14043

AUTHORIZED SIGNATURE 

TYPED NAME OF AUTHORIZED SIGNATURE

TITLE President TELEPHONE NO. 716-681-7331

(Rev. 1/2000)

ERIE COUNTY OFFICE BUILDING, 95 FRANKLIN STREET, BUFFALO, NEW YORK 14202 (716) 858-6395

**County of Erie**  
**DIVISION OF PURCHASE**  
**BID SPECIFICATIONS**  
**BID NO. 230311-002**

Ship to:  
 Attention:

Ship Via:  
 Date Required at Destination:

CATALOG NO./DESCRIPTION			
			The contract is located in Erie County, New York, in Erie County Sewer Districts No. 1, 2, 3, 4, 5, 6, & 8.
			The scope of work generally includes open cut excavation spot repairs or installations a for existing sanitary sewers, forcemain sewers, manholes, and associated restoration and appurtenant services as further detailed in the Specifications and Standard Details.
			Assignments will be completed on a work order basis.
			The contract is a Prevailing Wage Project See Exhibit PW.
			The term construction contract will be in place for a period of two years.
			The County reserves the right to award to more than one Contractor.
			<b><u>Bidders shall print, complete and submit the following:</u></b>
			Invitation to Bid (33 pages including Exhibits),
			Bid Form (Section 00 41 13 – 15 pages including Exhibits BF-2 & BF-3),
			NYS Certified Apprenticeship Training Program (Section 00 73 38 – 1 page)
			Prime Contractor Affidavit (Section 00 73 39 – 1 page),
			Executive Order No. 18 Attestation and Statement of Workforce – 1 page),
			Acknowledgement of Wage Rates (Section 00 73 43 – 1 page),
			& NYS Vendor Responsibility Questionnaire (Section 00 73 75 – 19 pages)
			A Pre-Bid Conference is scheduled for Tuesday, December 19 <sup>th</sup> at 10:00 AM at Erie County Rath Building Room 1004, 95 Franklin Street, Buffalo, NY
			For questions contact Erie County Division of Sewerage Management Nadine R. Wetzel, P.E., <a href="mailto:nadine.wetzel@erie.gov">nadine.wetzel@erie.gov</a> , 716-858-6145

**NOTE:** Bid results cannot be given over the phone. All requests for bid results should be submitted in writing or faxed to:

**ERIE COUNTY DIVISION OF PURCHASE**  
 Freedom of Information Officer  
 95 Franklin Street, Rm. 1254  
 Buffalo, NY 14202  
 FAX #: 716/858-6465

**NAME OF BIDDER** Visone Construction, Inc

(Rev. 9/95)



**County of Erie**  
**DIVISION OF PURCHASE**  
**INSTRUCTIONS TO BIDDERS (FORMAL)**

1. BID SHALL BE SUBMITTED ON THESE COUNTY OF ERIE BID FORMS or bid will not be considered. Bid must be typed or printed in ink. Original autograph signatures in ink are required. Facsimile or rubber stamp signatures will not be accepted. ALL PAGES OF THIS BID DOCUMENT MUST BE RETURNED INTACT.
2. LATE PROPOSALS. Any bids received in the Erie County Division of Purchase after the date and time prescribed will not be considered for contract award.
3. EMERGENCY CLOSINGS. In the event the closing of certain County facilities and/or operations and/or services due to any flood, fire, fire drill, power failure, uncontrolled weather conditions or other cause beyond the Division of Purchase control, only bids received in the Division of Purchase prior to the date and time or postmarked as of the date prescribed will be considered for contract award.
4. ANY CHANGE IN WORDING OR INTERLINEATION BY A BIDDER OF THE INQUIRY AS PUBLISHED BY THE COUNTY OF ERIE shall be reason to reject the proposal of such bidder, or in the event that such change in the Invitation to Bid is not discovered prior to entering into a contract, to void any contract entered into pursuant to such bid.
5. THE COUNTY RESERVES THE RIGHT TO REJECT any and all bids, to accept either in whole or in part any one bid or combination of bids, as may be provided in the bid specifications, or to waive any informalities in bids. The County does not obligate itself to accept the lowest or any other proposal.
6. AWARD TO THE LOWEST RESPONSIBLE BIDDER. For the purpose of determining which bidder is the lowest qualified responsible bidder, it shall be the lowest three bidders' responsibility, within FIVE DAYS of being so notified by the Division of Purchase, to present information and documentation to the Division of Purchase, to satisfy the County that the bidder possesses sufficient capital resources, skill, judgment and experience to perform the work or deliver the material, as per bid specifications.
7. CONTRACT(S) OR PURCHASE ORDER(S) WILL BE AWARDED after due consideration of the suitability of goods and/or services bid to satisfy these specifications, the total cost of such goods and/or services including all cost elements, and the timeliness of the agreed upon delivery date.
8. This EXECUTORY CLAUSE shall be a part of any agreement entered into pursuant to this bid:  
  
IT IS UNDERSTOOD BY THE PARTIES THAT THIS AGREEMENT SHALL BE EXECUTORY ONLY TO THE EXTENT OF THE MONIES AVAILABLE TO THE COUNTY OF ERIE AND APPROPRIATED THEREFOR, AND NO LIABILITY ON ACCOUNT THEREOF SHALL BE INCURRED BY THE COUNTY BEYOND THE MONIES AVAILABLE AND APPROPRIATED FOR THE PURPOSE THEREOF.
9. FAILURE TO MEET DELIVERY SCHEDULE as per accepted bid may result in legal action by the County of Erie to recover damages.
10. PRICES SHALL BE QUOTED F.O.B. DESTINATION AND DELIVERED INSIDE. "Tailgate delivery" will not be accepted unless specified by the County.
11. COLLECT TRANSPORTATION CHARGES WILL NOT BE PAID BY THE COUNTY. All freight, cartage, rigging, postage or other transportation charges shall be prepaid and included in the bid. There will be no additional charges for delivery.
12. NO TAXES ARE TO BE BILLED TO THE COUNTY. Bids shall not include any Federal, State, or local excise, sales, transportation, or other tax, unless Federal or State law specifically levies such tax on purchases made by a political subdivision. The County of Erie Purchase Order is an exemption certificate. Any applicable taxes from which the County is not exempt shall be listed separately as cost elements, and added into the total net bid.
13. THE SUCCESSFUL BIDDER shall comply with all laws, rules, regulations and ordinances of the Federal Government, the State of New York and any other political subdivision of regulatory body which may apply to its performance under this contract.

ERIE COUNTY OFFICE BUILDING, 95 FRANKLIN STREET, BUFFALO, NEW YORK 14202 (716) 858-6395



# County of Erie

## DIVISION OF PURCHASE

14. GRATUITIES, ILLEGAL OR IMPROPER SCHEMES. The County may terminate this agreement if it is determined that gratuities in the form of entertainment, gifts or otherwise were offered or given by a vendor, his agent or representative to any County official or employee with a view towards securing favorable treatment with respect to the awarding of this bid or the performance of this agreement. The County may also terminate this agreement if it is determined that the successful bidder engaged in any other illegal or improper scheme promotive of favoritism or unfairness incidental to the bidding process or the performance of this agreement. In the event that it is determined that said improper or illegal acts occurred, the County shall be entitled to terminate this agreement and/or exercise any other remedy available to it under existing law.

15. INSURANCE shall be procured by the Successful Bidder before commencing work, no later than 14 days after notice of award and maintained without interruption for the duration of the Contract, in the kinds and amounts specified in Exhibit IC, unless otherwise stipulated in these Bid Specifications. IF THE INSURANCE IS NOT PROVIDED IN ACCEPTABLE FORM WITHIN THIS PERIOD OF TIME, THEN THE DIRECTOR OF PURCHASE MAY DECLARE THE VENDOR NONRESPONSIVE AND AWARD THE CONTRACT TO THE NEXT LOW RESPONSIBLE BIDDER.

CERTIFICATES OF INSURANCE shall be furnished by the successful bidder on Erie County Standard Insurance Certificate, Exhibit IC.

16. ANY CASH DISCOUNT which is part of bid will be considered as a reduction in the bid prices in determining the award of the bid. Date of invoice must not precede date of delivery. The County policy is to pay all claims in a timely manner within the specified time. However, if for some reason payment is delayed, the County will take the discount when payment is made. The County will not pay any interest charges, nor refund discount amounts taken after the discount period. If this is unsatisfactory, please quote net.

17. CHANGES IN THE WORK. The County may, as the need arises, through the Director of Purchase, order changes in the work through additions, deletions, or modifications without invalidating the contract. Compensation, as it may be affected by any change, shall be adjusted by agreement between the contractor and County through the Director of Purchase.

18. BID OFFERING MATERIAL OTHER THAN THAT OF SPECIFIED MANUFACTURER OR TRADE NAME will be considered unless stated otherwise. The use of the name of a particular manufacturer, trade name, or brand in describing an item does not restrict a bidder to that manufacturer or specific article. However, the substituted article on which a proposal is submitted must be of such character or quality that it would serve the purpose for which it is to be used equally well as the manufacturer or brand specified. Proposals will be accepted in accordance with specifications on file or approved equal.

19. IF MATERIAL OR SERVICES OTHER THAN THOSE SPECIFIED IN THIS BID DOCUMENT ARE OFFERED, the bidder must so state and furnish at the time of bid opening, if so requested, and as part of his bid the following information in duplicate:

- (a) Complete description of the item offered, and detailed explanation of the differences between the item specified and the item offered. If, in the opinion of the Division of Purchase, sufficient detail is not presented as a part of the sealed bid to permit definitive evaluation of any substitute item, the bid will not be considered.
- (b) Descriptive literature of item offered, for evaluation.
- (c) List of installations in Erie County of the item offered.
- (d) List of other installations.

20. ANY ADDITIONAL INFORMATION for which bidder desires to add to the bid shall be written on a separate sheet of paper, attached to and submitted with the formal sealed bid, to be read at the formal opening.

21. WORKMANSHIP MUST MEET WITH THE APPROVAL OF THE DEPARTMENT HEAD(S) INVOLVED, AND SHALL BE FIRST CLASS in every respect without exception and shall be equal to the best modern practices. Materials furnished are to be new and unused. All materials furnished or work performed are to be guaranteed free from defects. Anything found defective or not meeting specifications, no matter in what stage of completion, may be rejected and shall be made good by the contractor at his own expense.

22. CONTRACTOR SHALL CLEAN UP and remove all debris and rubbish resulting from the work and leave the premises broom clean to the approval of the department head.

## County of Erie

### DIVISION OF PURCHASE

23. THIS BID IS FIRM AND IRREVOCABLE for a period of 45 days from the date and time of the bid opening. If a contract is not awarded within the 45-day period, a bidder to whom the bid has not been awarded, may withdraw his bid by serving written notice of his intention to do so upon the Division of Purchase. Upon withdrawal of the bid pursuant to this paragraph, the Division of Purchase will forthwith return the bidder's security deposit.

24. PRICES CHARGED TO THE COUNTY OF ERIE are to be no higher than those offered to any other governmental or commercial consumer. If a bidder has a New York State or a Federal GSA contract for any of the items covered in this bid or any similar items, he shall so indicate that he has said contract on these bid papers and automatically supply a copy of this contract within five days after notification of award.

25. PRICE IS FIRM. The unit prices bid shall remain firm, and any other charges bid shall also remain firm, for delivery of the equipment, material, work, or services described in this bid. No cost increase shall be charged for any reason whatsoever.

26. EXTENSION OF PRICE PROTECTION. Any contract entered into pursuant to this bid to supply the County's requirements of goods and/or services for a definite period of time as stated in the attached specifications may be extended for not more than two successive periods of equal length at the same bid price upon the mutual agreement of the successful bidder and the County. All extensions shall be submitted in writing and shall have prior approval by the County of Erie, Director of Purchase.

27. IN EXECUTING THIS BID, THE BIDDER AFFIRMS that all of the requirements of the specifications are understood and accepted by the bidder, and that the prices quoted include all required materials and services. The undersigned has checked all of the bid figures, and understands that the County will not be responsible for any errors or omissions on the part of the undersigned in preparing this bid. Mistakes or errors in the estimates, calculations or preparation of the bid shall not be grounds for the withdrawal or correction of the bid or bid security. In case of error in extension of prices in the bid, the unit price will govern.

28. ACCOUNTABILITY. The undersigned shall be fully accountable for his or its performance under this bid, or any contract entered into pursuant to this bid, and agrees that he, or its officers, will answer under oath all questions relevant to the performance thereof and to any transaction, act or omission had, done or omitted in connection therewith if called before any Judicial, County or State officer or agency empowered to investigate the contract or his performance.

29. TERMINATION OF CONTRACT:

a. At its option, the County may at any time for any reason terminate this agreement and the Contractor shall immediately cease all work under the agreement upon receipt of written notice of such termination from the County.

b. In the event of termination for any reason other than the fault of the Contractor, or the nonavailability of funds as provided in the above Executory Clause, the Contractor shall be paid the amount due to date of termination, and all reasonable expenses caused by such termination.

30. THE SUCCESSFUL BIDDER TO WHOM THE BID IS AWARDED SHALL INDEMNIFY AND HOLD HARMLESS the County of Erie and its agents and employees from and against all claims, damages, losses or causes of action arising out of or resulting from such vendor's performance pursuant to this bid.

31. STATUS AS AN INDEPENDENT CONTRACTOR: The successful Bidder to whom the bid is awarded and the County agree that the Bidder and its officers, employees, agents, contractors, subcontractors and/or consultants are independent contractors and not employees of the County or any department, agency or unit thereof. In accordance with their status as independent contractors, the Bidder covenants and agrees that neither the Bidder nor any of its officers, employees, agents, contractors, subcontractors and/or consultants will hold themselves out as, or claim to be, officers or employees of the County or any department, agency or unit thereof.

32. GOVERNED BY NEW YORK LAW: This Agreement shall be construed and enforced in accordance with the laws of the State of New York. In addition, the parties hereby agree that for any cause of action arising out of this Agreement shall be brought in the County of Erie.

(Rev. 04/09)

# County of Erie

## DIVISION OF PURCHASE

To facilitate correct drawing and execution of contract, bidder shall supply full information concerning legal status:

FIRM NAME Visone Construction, Inc

ADDRESS OF PRINCIPAL OFFICE STREET 79 Sheldon Ave

CITY Depew

AREA CODE 716 PHONE 681-4331 STATE N.Y ZIP 14043

Check one: CORPORATION  PARTNERSHIP  INDIVIDUAL

INCORPORATED UNDER THE LAWS OF THE STATE OF NY

If foreign corporation, state if authorized to do business in the State of New York:

YES  NO

TRADE NAMES: \_\_\_\_\_

ADDRESS OF LOCAL OFFICE STREET \_\_\_\_\_

CITY \_\_\_\_\_

AREA CODE \_\_\_\_\_ PHONE \_\_\_\_\_ STATE \_\_\_\_\_ ZIP \_\_\_\_\_

NAMES AND ADDRESSES OF PARTNERS:

David Visone 79 Sheldon Ave, Depew, NY 14043

\_\_\_\_\_

\_\_\_\_\_

\_\_\_\_\_

# County of Erie

DIVISION OF PURCHASE

## ASSIGNMENT OF PUBLIC CONTRACTS

### GENERAL MUNICIPAL LAW - Section 109:

1. A clause shall be inserted in all specifications of contracts hereafter made or awarded by an officer, board or agency of a political subdivision, or any district therein, prohibiting any contractor, to whom any contract shall be let, granted or awarded, as required by law, from assigning, transferring, conveying, subletting or otherwise disposing of the same, or of his right, title or interest therein, or his power to execute such contract, to any other person or corporation without the previous consent in writing of the officer, board or agency awarding the contract.

2. If any contractor, to whom any contract is let, granted, or awarded, as required by law, by any officer, board or agency of a political subdivision, or of any district therein, without the previous written consent specified in subdivision one (1) of this section, assign, transfer, convey, sublet or otherwise dispose of such contract, or his right, title or interest therein, or his power to execute such contract to any other person or corporation, the officer, board or agency which let, made, granted or awarded such contract shall revoke and annul such contract, and the political subdivision or district therein, as the case may be, and such officer, board or agency shall be relieved and discharged from all liability and obligations growing out of such contract to such contractor, and to the person or corporation to which such contract shall have been assigned, transferred, conveyed, sublet or otherwise disposed of, and such contractor, and his assignee, transferee or sublessee shall forfeit and lose all monies, theretofore earned under such contract, except so much as may be required to pay his employees. The provisions of this section shall not hinder, prevent or affect any assignment by any such contractor for the benefit of his creditors made pursuant to the laws of the State.

NO ASSIGNMENT OF ANY AGREEMENT pursuant to this bid shall be made without specific prior approval, in writing, by the Erie County Director of Purchase.

(Rev. 12/01/93)



## COUNTY OF ERIE DIVISION OF PURCHASE

### PURCHASES BY OTHER LOCAL GOVERNMENTS OR SPECIAL DISTRICTS

The Erie County Legislature has adopted the following resolution for the purpose of allowing the following-named local governmental or school districts to make purchases through the County bidding procedures.

Under the following conditions, the Director of Purchase may make purchasing services available to the following 88 participants:

1. When in the opinion of the Director of Purchase it will not create any burden or hardship upon the County and the anticipated prices will not be adversely affected thereby, the Director is authorized when he deems appropriate and as may be requested by the participants to provide in any particular County bid specification that the participants in Erie County shall have the right to make purchases based upon the bids received by the County.
2. The County Purchase Director, within the limits of his time and manpower, shall disseminate relevant contract information to the participants.
3. The participants in County contracts will issue purchase orders directly to vendors within the specified contract period referencing the County contract involved and be liable for any payments due on such purchase orders.

Bidders shall take notice that as a condition of the award of a County contract pursuant to these specifications, the successful bidder agrees to accept the award of a similar contract with any of the participants in Erie County if called upon to do so. The County, however, will not be responsible for any debts incurred by participants pursuant to this or any other agreement.

Necessary deviations from the County's specifications in the award of a participant's contract, particularly as such deviations may relate to quantities or delivery point, shall be a matter to be resolved between the successful bidder and participants. All inquiries regarding prospective contracts shall be directed to the attention of:

AKRON CENTRAL SCHOOL DISTRICT, District Clerk, 47 Bloomingdale Ave., Akron, NY 14001  
 AKRON VILLAGE OF, Clerk-Treasurer, 21 Main St., Akron, NY 14001  
 ALDEN CENTRAL SCHOOL DISTRICT, District Clerk, 13190 Park St., Alden, NY 14004  
 ALDEN TOWN OF, Town Clerk, Town Hall, 11901 Broadway, Alden, NY 14004  
 ALDEN VILLAGE OF, Village Clerk, 13336 Broadway, Alden, NY 14004  
 AMHERST CENTRAL SCHOOL DISTRICT, Business Manager, 4301 Main St., Amherst, NY 14226  
 AMHERST TOWN OF, Highway Superintendent, Town Hall, 5583 Main St., Williamsville, NY 14221  
 AMHERST TOWN OF, Town Supervisor, Town Hall, 5583 Main St., Williamsville, NY 14221  
 ANGOLA VILLAGE OF, Clerk-Treasurer, 41 Commercial St., Angola, NY 14006  
 AURORA TOWN OF, Town Clerk, Town Hall, 5 S. Grove St., E. Aurora, NY 14052  
 BLASDELL VILLAGE OF, Clerk-Treasurer, 121 Miriam St., Blasdell, NY 14219  
 BOCES, ERIE #1, Clifford N Crooks Svc. Ctr., 355 Harlem Rd. West Seneca NY 14224-1892  
 BOCES, ERIE CATTARAUGUS #2, Assistant Superintendent, 3340 Baker Rd., Orchard Park, NY 14127  
 BOSTON TOWN OF, Town Clerk, Town Hall, 8500 Boston State Rd., Boston, NY 14025  
 BRANT TOWN OF, Town Clerk, Town Hall, Brant North Collins Rd., Brant, NY 14027  
 BUFFALO BOARD OF EDUCATION, Purchasing Agent, 408 City Hall, Buffalo, NY 14202  
 BUFFALO CITY OF, Division of Purchasing, 1901 City Hall, Buffalo, NY 14202  
 BUFFALO MUNICIPAL HOUSING AUTHORITY, 300 Perry St., Buffalo, NY 14204-2299  
 BUFFALO SEWER AUTHORITY, General Manager, 1038 City Hall, Buffalo, NY 14202-3378  
 CHEEKTOWAGA CENTRAL SCHOOL DISTRICT, 3600 Union Rd., Cheektowaga, NY 14225  
 CHEEKTOWAGA-MARYVALE UNION FREE SCHOOL DISTRICT, District Clerk, 1050 Maryvale Dr., Cheektowaga, NY 14225-2386  
 CHEEKTOWAGA-SLOAN UNION FREE SCHOOL DISTRICT, District Clerk, 166 Halstead Ave., Sloan, NY 14212-2295  
 CHEEKTOWAGA TOWN OF, Town Hall, Broadway & Union Rds., Cheektowaga, NY 14227  
 CLARENCE CENTRAL SCHOOL DISTRICT, Business Administrator, 9625 Main St., Clarence, NY 14031-2083  
 CLARENCE TOWN OF, Town Clerk, 1 Town Place, Clarence, NY 14031  
 CLEVELAND HILL FIRE DISTRICT NO. 6, Secretary, 440 Cleveland Dr., Cheektowaga, NY 14225  
 CLEVELAND HILL U.F.S.D. @ CHEEKTOWAGA, Business Manager, 105 Mapleview Dr., Cheektowaga, NY 14225

COLDEN TOWN OF, Deputy Town Clerk, Town Hall, S-8812 State Rd., Colden, NY 14033  
 COLLINS TOWN OF, Supervisor, Town Hall, P.O. Box 420, Collins, NY 14035  
 CONCORD TOWN OF, Town Clerk, Town Hall, Springville, NY 14141-0187  
 DEPEW UNION FREE SCHOOL DISTRICT, District Clerk, 591 Terrace Blvd., Depew, NY 14043  
 DEPEW VILLAGE OF, Village Clerk, Municipal Building, 85 Manitou St., Depew, NY 14043  
 EAST AURORA VILLAGE OF, Village Clerk, Village Hall, 571 Main St., East Aurora, NY 14052  
 EDEN TOWN OF, Town Clerk, 2795 East Church St., Eden, NY 14057  
 EGGERTSVILLE FIRE DISTRICT, Secretary/Treasurer, 1880 Eggert Rd., Eggertsville, NY 14226-2233  
 ELLWOOD FIRE DISTRICT #1, Secretary, Town of Tonawanda, 1000 Englewood Ave., Kenmore, NY 14223  
 ELMA TOWN OF, Town Clerk, Town Hall, 1600 Bowen Rd., Elma, NY 14059  
 ERIE COUNTY MEDICAL CENTER, 462 GRIDER STREET, BUFFALO, NY 14215  
 ERIE COMMUNITY COLLEGE, South Campus Business Office, 4041 Southwestern Blvd., Orchard Park, NY 14127-2199  
 ERIE COUNTY WATER AUTHORITY, Central Processing, 3030 Union Rd., Buffalo, NY 14227  
 EVANS TOWN OF, Town Clerk, 42 N. Main St., Angola, NY 14006  
 FARNHAM VILLAGE OF, Village Clerk-Treasurer, 526 Commercial St., Farnham, NY 14061  
 FORKS FIRE DISTRICT #3, Commissioner, Town Cheektowaga, 3330 Broadway, Cheektowaga, NY 14227  
 GOWANDA VILLAGE OF, Clerk/Treasurer, 27 East Main St., Gowanda, NY 14070  
 GRAND ISLAND CENTRAL SCHOOL DISTRICT, District Clerk, 1100 Ransom Rd., Grand Island, NY 14072  
 GRAND ISLAND TOWN OF, Town Clerk, 2255 Baseline Rd., Grand Island, NY 14072  
 HAMBURG TOWN OF, Town Clerk, S-6100 S. Park Ave., Hamburg, NY 14075  
 HAMBURG VILLAGE OF, Village Clerk/Treasurer, 100 Main St., Hamburg, NY 14075  
 HOLLAND FIRE DISTRICT #1, Town of Holland, Holland, NY 14080  
 HOLLAND TOWN OF, Town Clerk, 47 Pearl St., Holland, NY 14080  
 HOPEVALE UNION FREE SCHOOL DISTRICT, District Clerk, 3780 Howard Rd., Hamburg, NY 14075  
 IROQUOIS CENTRAL SCHOOL DISTRICT, Girdle Rd., Elma, NY 14059  
 KENILWORTH FIRE DISTRICT #2, Commissioner, Tn. Tonawanda, 84 Hawthorne Ave., Buffalo, NY 14223  
 KENMORE-TN OF TONAWANDA UNION FREE SCHOOL DISTRICT, District Clerk, 1500 Colvin Blvd., Buffalo NY 14223  
 KENMORE VILLAGE OF, Village Clerk-Treasurer, Municipal Building, Kenmore, NY 14217  
 LACKAWANNA CITY OF, City Clerk, Lackawanna City Hall, 714 Ridge Rd., Lackawanna, NY 14218  
 LAKE VIEW FIRE DISTRICT, Fire Commissioner, Lakeview & Burke Roads, Lake View, NY 14085  
 LANCASTER TOWN OF, Town Clerk, 21 Central Avenue, Lancaster, NY 14086  
 LANCASTER VILLAGE OF, Clerk-Treasurer, Municipal Building, 5423 Broadway, Lancaster, NY 14086  
 MARILLA TOWN OF, Marilla Town Hall, 1740 Two Rod Rd., Marilla, NY 14102  
 MONROE ONE BOCES, Educational Services, 41 O'Connor Rd., Fairport, NY 14450  
 NEWSTEAD TOWN OF, Town Clerk, Town Hall, P.O. Box 227, Akron, NY 14001  
 NIAGARA FRONTIER TRANSPORTATION AUTHORITY, 181 Ellicott St., Buffalo, NY 14205  
 NORTH COLLINS TOWN OF, Town Clerk 2015 Spruce St., North Collins, NY 14111  
 NORTH COLLINS VILLAGE OF, Village Clerk, 10543 Main St., North Collins, NY 14111  
 ORCHARD PARK CENTRAL SCHOOL DISTRICT, Asst. Supt. Bus. & Support Svcs. 3330 Baker Rd., Orchard Park, NY 14127  
 ORCHARD PARK TOWN OF, Town Clerk, Municipal Bldg., 4295 S. Buffalo St., Orchard Park, NY 14127  
 ORCHARD PARK VILLAGE OF, Clerk, Municipal Bldg., 4295 S. Buffalo St., Orchard Park, NY 14127  
 SARDINIA TOWN OF, Town Clerk, Town Hall, Savage Rd., Sardinia, NY 14134  
 SHERIDAN PARK FIRE DISTRICT NO. 4, Secretary, 738 Sheridan Dr., Tonawanda, NY 14150  
 SLOAN VILLAGE OF, Clerk Treasurer, 425 Reiman St., Sloan, NY 14212  
 SNYDER VOL. FIRE DEPT., Fire Commissioner, 4531 Main Street, Snyder, NY 14226  
 SOUTH LINE FIRE DISTRICT #10, Fire Commissioner, 1049 S. French Rd., S. Cheektowaga, NY 14227  
 SOUTH WALES FIRE DISTRICT #1, Secretary/Treasurer, P.O.Box 94, South Wales, NY 14139  
 SPRING BROOK FIRE DISTRICT #1, Secretary, P.O. Box 97, Spring Brook, NY 14140  
 SPRINGVILLE VILLAGE OF, Clerk Treasurer, Village Office, 5 W. Main St., Springville, NY 14141  
 SUNY ERIE COMMUNITY COLLEGE, 6205 Main St., Williamsville, NY 14221  
 SWEET HOME CENTRAL SCHOOL DISTRICT, Director Finance & Plant Svcs., 1901 Sweet Home Rd., Amherst, NY 14228  
 TONAWANDA CITY OF, Mayor, 200 Niagara St., Tonawanda, NY 14150  
 TONAWANDA CITY OF, Superintendent, 150 Fillmore Avenue, Tonawanda, NY 14150  
 TONAWANDA CITY SCHOOL DISTRICT, District Clerk, 100 Hinds St., Tonawanda, NY 14150-1815  
 TONAWANDA TOWN OF, Town Clerk, Municipal Building, Kenmore, NY 14217  
 U-CREST FIRE DISTRICT #4, Fire Commissioner, 255 Clover Place, Cheektowaga, NY 14225  
 UNION FREE SCHOOL DISTRICT, Dist. Clerk, Tn. Tonawanda, 1500 Colvin Blvd., Kenmore, NY 14223  
 WALDEN FIRE DISTRICT #2, Fire Commissioner, 20 Pine Ridge Road, Cheektowaga, NY 14211  
 WALES TOWN OF, Town Clerk, Big Tree Rd., Wales Center, NY 14169  
 WEST SENECA CENTRAL SCHOOL DISTRICT, District Treasurer, 1397 Orchard Park Rd., West Seneca, NY 14224-4098  
 WEST SENECA FIRE DISTRICT #4, Fire Commissioner, 100 Lein Rd., West Seneca, NY 14224  
 WEST SENECA FIRE DISTRICT #5, Fire Commissioner, 2801 Seneca St., West Seneca, NY 14224  
 WEST SENECA TOWN OF, Town Clerk, 1250 Union Road, West Seneca, NY 14224  
 WILLIAMSVILLE CENTRAL SCHOOL DISTRICT, District Clerk, 105 Casey Rd, PO Box 5000, East Amherst NY 14051  
 WILLIAMSVILLE VILLAGE OF, 5565 Main St., Williamsville, NY 14231-1557  
 WYOMING, COUNTY OF, Office of the Board of Supervisors, 143 N Main St., Warsaw, NY 14569  
 REV. 11/2021





# County of Erie

MARK C. POLONCARZ

COUNTY EXECUTIVE

DIVISION OF PURCHASE

## CONSTRUCTION/RECONSTRUCTION CONTRACTS

1. DISCRIMINATION. The successful bidder agrees:

(a) that in the hiring of employees for the performance of work under this contract or any subcontract hereunder, no contractor, subcontractor, nor any person acting on behalf of such contractor or subcontractor, shall by reason of race, creed, color, sex or national origin discriminate against any citizen of the State of New York who is qualified and available to perform the work to which the employment relates;

(b) that no contractor, subcontractor, nor any person on his behalf shall, in any manner, discriminate against or intimidate any employee hired for the performance of work under this contract on account of race, creed, color, sex or national origin;

(c) that there may be deducted from the amount payable to the contractor by the County of Erie under this contract a penalty of fifty dollars for each person for each calendar day during which such person was discriminated against or intimidated in violation of the provisions of the contract;

(d) that this contract may be cancelled or terminated by the County of Erie and all monies due or to become due hereunder may be forfeited, for a second or any subsequent violation of the terms or conditions of this section of the contract; and

(e) the aforesaid provisions of this section covering every contract for or on behalf of the County of Erie for the manufacture, sale or distribution of materials, equipment or supplies shall be limited to operations performed within the territorial limits of the State of New York. (N.Y. State Labor Law Article 8 Section 220-e)

(f) Provisions of the State Law Against Discrimination also prohibit discrimination in employment because of age.

2. CONSTRUCTION, RECONSTRUCTION, OR REPAIR CONTRACTS FOR PUBLIC WORKS FACILITIES are subject to minimum wage rates, as established by the State of New York Department of Labor. The successful bidder on any contract for public works to which the provisions of the New York State Labor Law Article 8 apply agrees that:

(a) No laborer, workman or mechanic in the employ of the contractor, subcontractor or other person doing or contracting to do the whole or a part of the work contemplated by the contract shall be permitted or required to work more than eight hours in any one calendar day or more than five days in any one week except in cases of extraordinary emergency including fire, flood or danger to life or property. (Section 220, subd. 2, N.Y. State Labor Law)

(b) Each laborer, workman or mechanic employed by the contractor, subcontractor or other person doing or contracting to do the whole or part of the work contemplated by the contract shall be paid not less than the hourly minimum rate of wage and provided supplements not less than the prevailing supplements as designated by the New York State Industrial Commission. (Section 220, subd. 3, N.Y. State Labor Law)

Wage and supplement rates are on file in the Division of Purchase.

3. AFFIRMATIVE ACTION PROGRAM AFFECTING CONSTRUCTION CONTRACTS. The Erie County Legislature has adopted a resolution directing that County Construction Contracts require the contractor to take affirmative action to secure equal opportunity for minority group workers and to comply with the Affirmative Action Program of the County of Erie. The Legislative resolution provides that a contract for the purchase of equipment involving installation work by building trade employees shall be considered a construction contract if the number of such employees on the job site shall at any time exceed ten (10). If the contractor intends to have more than ten (10) such employees on the job site at any one time, it shall be the contractor's obligation to make a written request to the Director of the Division of Purchase for a copy of the special conditions pertaining to affirmative action. The contractor shall not, at any time, place more than ten (10) such employees on the job site except in compliance with the said resolution and the said special conditions.

ERIE COUNTY OFFICE BUILDING, 95 FRANKLIN STREET, BUFFALO, NY 14202 (716) 858-6395

### Erie County Equal Pay Certification

In order to comply with Executive Order 13 dated November 6, 2014, we hereby certify that we are in compliance with federal law, including the Equal Pay Act of 1963, Title VII of the Civil Rights Act of 1964, Federal Executive Order 11246 of September 24, 1965 and New York State Labor Law Section 194 (together "Equal Pay Law"). We understand that this certification is a material component of this contract. Violation of the provisions of Executive Order 13, which is attached hereto and made a part hereof, can constitute grounds for the immediate termination of this contract and may constitute grounds for determining that a bidder is not qualified to participate in future county contracts.

We have evaluated wages and benefits to ensure compliance with the Equal Pay Law.

We certify that we have not been the subject of an adverse finding under the Equal Pay Law within the previous five years and, in the alternative, if we were the subject of an adverse finding under the Equal Pay Law within the previous five years, we have annexed a detailed description of the finding(s). In addition, we have annexed a detailed description of any currently pending claims under the Equal Pay Law in which we are involved.



Signature

### Verification

STATE OF New York )  
COUNTY OF Erie ) SS:  
A)

\_\_\_\_\_, being duly sworn, states he or she is the owner of (or a partner in) \_\_\_\_\_, and is making the foregoing Certification and that the statements and representations made in the Certification are true to his or her own knowledge.

B)  
David Visone, being duly sworn, states that he or she is the Name of Corporate Officer President, of Visone Construction Inc., Title of Corporate Officer Name of Corporation the enterprise making the foregoing Certification, that he or she has read the Certification and knows its contents, that the statements and representations made in the Certification are true to his or her own knowledge, and that the Certification is made at the direction of the Board of Directors of the Corporation.

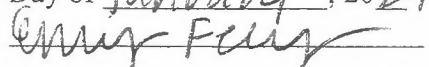
Sworn to before me this 11  
Day of January, 2024  

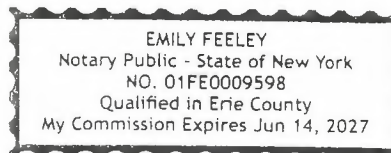



Division of Purchase  
EEO Compliance Place Card

\*\*\*\*\*

Date Sent 8/22/24

Buyer JK

Bid # 230311-002

Bid Title SANITARY SEWER OPEN CUT REPAIR

Comments

-----  
-----  
-----  
-----

EEO Sign-off  Date 8/29/2024

BID NO: ECSD No 1-8 # 96  
 BID DATE: 11/2/24

**ERIE COUNTY MINORITY/WOMEN BUSINESS ENTERPRISE & SERVICE-DISABLED  
 VETERAN-OWNED BUSINESS UTILIZATION REPORT- PART A**

COMPANY: Visone Construction, Inc  
 AUTHORIZED REPRESENTATIVE: David Visone  
 ADDRESS: 79 Sheldon Ave Depew NY 14043  
 TELEPHONE NUMBER: 716-681-7331  
 PROJECT NAME: ECSD No 12345678  
 PROJECT NUMBER: Contract No 96

I. List actions taken to identify, solicit, and contact Minority Business Enterprise (MBE), Women Business Enterprise (WBE) & Service-Disabled Veteran-Owned Business (SDVOB) to bid on subcontracts for this project.

1. Deal with these vendors all the time
2. \_\_\_\_\_
3. \_\_\_\_\_
4. \_\_\_\_\_
5. \_\_\_\_\_
6. \_\_\_\_\_

II. List all bona-fide Minority/Women Business Enterprise & Service-Disabled Veteran-Owned Businesses, sub-contractors, suppliers, professional personnel, solicited, contracted, or presently negotiating a contract in accordance with the minority business utilization goal set forth by the County of Erie.

MBE/WBE/SDVOB OWNED FIRMS	SUPPLY/SER VICE	AMOUNT OF PROPOSAL	PRIOR CERTIFICATION	CONTRACT EXECUTED	REASON IF CONTRACT NOT AWARDED
---------------------------	-----------------	--------------------	---------------------	-------------------	--------------------------------

NAME: PAVILION Drainage Supply Co Inc  
 ADDRESS: PO Box 219  
 CITY, STATE: Pavilion, N.Y. 14525  
 TELEPHONE: 585-584-3221  
 IRS #: \_\_\_\_\_

YES Will contact them when needed

NO

MBE/WBE/SDVOB OWNED FIRMS	SUPPLY/SER VICE	AMOUNT OF PROPOSAL	PRIOR CERTIFICATION	CONTRACT EXECUTED	REASON IF CONTRACT NOT AWARDED
---------------------------	-----------------	--------------------	---------------------	-------------------	--------------------------------

NAME: Bison Contracting + Builders Supply Corp  
 ADDRESS: 885 Bailey Ave  
 CITY, STATE: Buffalo NY 14206  
 TELEPHONE: 716-821-1995  
 IRS #: \_\_\_\_\_

YES Will contact them when needed

NO

MBE/WBE/SDVOB OWNED FIRMS	SUPPLY/SER VICE	AMOUNT OF PROPOSAL	PRIOR CERTIFICATION	CONTRACT EXECUTED	REASON IF CONTRACT NOT AWARDED
---------------------------	-----------------	--------------------	---------------------	-------------------	--------------------------------

NAME: Iroquois Construction Services  
 ADDRESS: 155 Commerce Drive  
 CITY, STATE: Lackawanna NY 14218  
 TELEPHONE: 716-270-0433  
 IRS #: \_\_\_\_\_

YES

*will contact them when needed*

NO

MBE/WBE/SDVOB OWNED FIRMS	SUPPLY/SER VICE	AMOUNT OF PROPOSAL	PRIOR CERTIFICATION	CONTRACT EXECUTED	REASON IF CONTRACT NOT AWARDED
---------------------------	-----------------	--------------------	---------------------	-------------------	--------------------------------

NAME: Upstate Steel, Inc  
 ADDRESS: 1820 Dale Rd  
 CITY, STATE: Buffalo NY 14225  
 TELEPHONE: 716-892-8434  
 IRS #: \_\_\_\_\_

YES

*will contact them when needed*

NO

MBE/WBE/SDVOB OWNED FIRMS	SUPPLY/SER VICE	AMOUNT OF PROPOSAL	PRIOR CERTIFICATION	CONTRACT EXECUTED	REASON IF CONTRACT NOT AWARDED
---------------------------	-----------------	--------------------	---------------------	-------------------	--------------------------------

NAME: \_\_\_\_\_  
 ADDRESS: \_\_\_\_\_  
 CITY, STATE: \_\_\_\_\_  
 TELEPHONE: \_\_\_\_\_  
 IRS #: \_\_\_\_\_

YES

NO

ERIE DEPARTMENT OF PURCHASING  
OFFICE OF THE DIRECTOR

III. Assistance offered by contractor to MBE's/WBE's/SDVOB's as to bonding, union requirements obtaining work capital, etc.

- 1. \_\_\_\_\_
- 2. \_\_\_\_\_
- 3. \_\_\_\_\_
- 4. \_\_\_\_\_
- 5. \_\_\_\_\_
- 6. \_\_\_\_\_

IV. Total Dollar Amount to be subcontracted to:

Minority Business Enterprise(s) \$ \_\_\_\_\_  
Women Business Enterprise(s). (if applicable) \$ \_\_\_\_\_  
Service-Disabled Veteran-Owned Business(s) \$ \_\_\_\_\_

V. Total Amount of Bid \$ \_\_\_\_\_

VI. MBE Percent (%) of project bid: (EC goal is 15%) \_\_\_\_\_ %  
WBE Percent (%) of project bid: (EC goal is 5%) \_\_\_\_\_ %  
SDVOB Percent (%) of project bid: (EC goal is 6%) \_\_\_\_\_ %

VII. YOU MUST ATTACH COPIES OF RELEVANT CORRESPONDENCE AND DOCUMENTS, INCLUDING RETURN RECEIPTS UPON LOW BIDDER STATUS TO EEO.

  
SIGNATURE OF AUTHORIZED REPRESENTATIVE

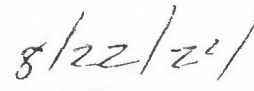
  
DATE

VIII. CONTRACTOR'S DESIGNATED EQUAL OPPORTUNITY OFFICER (EEO)

  
NAME

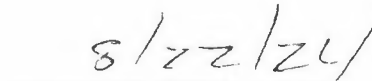
  
DATE

WAIVER RECOMMENDATION

COMPANY: Visore Construction Inc  
ADDRESS: 79 Sheldon Ave Depew NY 14043  
TELEPHONE NUMBER: (716) 681-7331 BID NO.: NO1-8 Contract #96

- 1. Vendor has made a good faith effort to subcontract on this bid for which minority/women/service-disabled veteran-owned business enterprises, bids could be solicited; and
- 2. The total percentage of the bid which could be subcontracted for which minority business enterprises bids could be solicited is less than 10% for MBEs, 2% WBEs, and 6% SDVOBs.

A waiver as provided for by Erie County Local Law, is hereby requested on the grounds that there are no/insufficient (circle the appropriate term) minority/women's business enterprises or service-disabled veteran-owned businesses in the market area of this bid.

- 1. We should be in good shape
- 2. unless vendors are too busy
- 3. to work with us or
- 4. availability
- 5. \_\_\_\_\_
- 8. \_\_\_\_\_
- 9. \_\_\_\_\_
- 10. \_\_\_\_\_

(Use additional sheets if necessary.)

If a partial waiver is granted, the Vendor will make a good faith effort to meet the reduced goal.

8/22/24 DATE Anthony J. Magan SIGNATURE OF AUTHORIZED COMPANY REPRESENTATIVE

Granted in Whole: \_\_\_\_\_

Granted in Part: \_\_\_\_\_

Comments:

\_\_\_\_\_  
\_\_\_\_\_  
[Signature] DIRECTOR OF E.E.O. 8-29-2024 DATE



# CERTIFICATE OF LIABILITY INSURANCE

DATE (MM/DD/YYYY)  
07/18/2024

THIS CERTIFICATE IS ISSUED AS A MATTER OF INFORMATION ONLY AND CONFERS NO RIGHTS UPON THE CERTIFICATE HOLDER. THIS CERTIFICATE DOES NOT AFFIRMATIVELY OR NEGATIVELY AMEND, EXTEND OR ALTER THE COVERAGE AFFORDED BY THE POLICIES BELOW. THIS CERTIFICATE OF INSURANCE DOES NOT CONSTITUTE A CONTRACT BETWEEN THE ISSUING INSURER(S), AUTHORIZED REPRESENTATIVE OR PRODUCER, AND THE CERTIFICATE HOLDER.

**IMPORTANT:** If the certificate holder is an ADDITIONAL INSURED, the policy(ies) must have ADDITIONAL INSURED provisions or be endorsed. If SUBROGATION IS WAIVED, subject to the terms and conditions of the policy, certain policies may require an endorsement. A statement on this certificate does not confer rights to the certificate holder in lieu of such endorsement(s).

<b>PRODUCER</b> Stahlka Agency, Inc 6724 Main St  Williamsville NY 14221		<b>CONTACT NAME:</b> Jenny Loretz <b>PHONE (A/C, No, Ext):</b> (716) 634-7070 <b>FAX (A/C, No):</b> (716) 634-6411 <b>E-MAIL ADDRESS:</b> jloretz@emsinsurance.com	
<b>INSURED</b> Visone Construction Inc 79 Sheldon Ave  Depew NY 14043		<b>INSURER(S) AFFORDING COVERAGE</b> <b>NAIC #</b>	
		<b>INSURER A:</b> Cincinnati Insurance Company	
		<b>INSURER B:</b> CorePointe Ins Co	
		<b>INSURER C:</b>	
		<b>INSURER D:</b>	
		<b>INSURER E:</b>	
		<b>INSURER F:</b>	

**COVERAGES**      **CERTIFICATE NUMBER:** 23-24 W 24-25 L A E      **REVISION NUMBER:**

THIS IS TO CERTIFY THAT THE POLICIES OF INSURANCE LISTED BELOW HAVE BEEN ISSUED TO THE INSURED NAMED ABOVE FOR THE POLICY PERIOD INDICATED. NOTWITHSTANDING ANY REQUIREMENT, TERM OR CONDITION OF ANY CONTRACT OR OTHER DOCUMENT WITH RESPECT TO WHICH THIS CERTIFICATE MAY BE ISSUED OR MAY PERTAIN, THE INSURANCE AFFORDED BY THE POLICIES DESCRIBED HEREIN IS SUBJECT TO ALL THE TERMS, EXCLUSIONS AND CONDITIONS OF SUCH POLICIES. LIMITS SHOWN MAY HAVE BEEN REDUCED BY PAID CLAIMS.

INSR LTR	TYPE OF INSURANCE	ADDL INSD	SUBR WVD	POLICY NUMBER	POLICY EFF (MM/DD/YYYY)	POLICY EXP (MM/DD/YYYY)	LIMITS
A	<input checked="" type="checkbox"/> COMMERCIAL GENERAL LIABILITY <input type="checkbox"/> CLAIMS-MADE <input checked="" type="checkbox"/> OCCUR <input checked="" type="checkbox"/> Contractual Liability <input checked="" type="checkbox"/> Independent Contractors  GEN'L AGGREGATE LIMIT APPLIES PER <input checked="" type="checkbox"/> POLICY <input type="checkbox"/> PRO. SECT <input type="checkbox"/> LOC OTHER	Y	Y	ENP 0607108	03/01/2024	03/01/2025	EACH OCCURRENCE \$ 1,000,000 DAMAGE TO RENTED PREMISES (Ea occurrence) \$ 500,000 MED EXP (Any one person) \$ 10,000 PERSONAL & ADV INJURY \$ 1,000,000 GENERAL AGGREGATE \$ 2,000,000 PRODUCTS - COMP/OP AGG \$ 2,000,000 OTHER \$
A	<b>AUTOMOBILE LIABILITY</b> <input checked="" type="checkbox"/> ANY AUTO OWNED AUTOS ONLY <input checked="" type="checkbox"/> HIRED AUTOS ONLY <input type="checkbox"/> SCHEDULED AUTOS NON-OWNED AUTOS ONLY	Y	Y	EBA 0607002	03/01/2024	03/01/2025	COMBINED SINGLE LIMIT (Ea accident) \$ 1,000,000 BODILY INJURY (Per person) \$ BODILY INJURY (Per accident) \$ PROPERTY DAMAGE (Per accident) \$ OTHER \$
A	<input checked="" type="checkbox"/> UMBRELLA LIAB <input checked="" type="checkbox"/> OCCUR <input type="checkbox"/> EXCESS LIAB <input type="checkbox"/> CLAIMS-MADE	Y	Y	ENP 0607108	03/01/2024	03/01/2025	EACH OCCURRENCE \$ 5,000,000 AGGREGATE \$ 5,000,000 DED    RETENTION \$ OTHER \$
B	<b>WORKERS COMPENSATION AND EMPLOYERS' LIABILITY</b> ANY PROPRIETOR/PARTNER/EXECUTIVE/OFFICER/MEMBER EXCLUDED? (Mandatory in NH) if yes, describe under DESCRIPTION OF OPERATIONS below	Y/N	N/A	CPW1001934	12/31/2023	12/31/2024	<input checked="" type="checkbox"/> PER STATUTE <input type="checkbox"/> OTH. ER E.L. EACH ACCIDENT \$ 100,000 E.L. DISEASE - EA EMPLOYEE \$ 100,000 E.L. DISEASE - POLICY LIMIT \$ 500,000

DESCRIPTION OF OPERATIONS / LOCATIONS / VEHICLES (ACORD 101 Additional Remarks Schedule, may be attached if more space is required)

Bid: ECSD No 1 2 3 4 5 6 8 Contract No 96 Sanitary Sewer Open Cut Repair Term Contract 2024-2026

County of Erie and any board, bureau, commission or agency and all others if required by written contract are additional insureds on a primary and noncontributory basis on the General Liability, Auto Liability and Umbrella policies

Waiver of Subrogation if required by written contract applies to the General Liability, Auto liability, Umbrella, and Workers Compensation policies

### CERTIFICATE HOLDER

### CANCELLATION

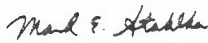
County of Erie 95 Franklin Street  Buffalo NY 14202	<div style="border: 2px solid black; padding: 5px; width: fit-content; margin: 0 auto;"> <p><b>APPROVED</b>  <b>JULY 30 2024</b>          AARON RUBIN          ERIE COUNTY DEPARTMENT OF LAW</p> </div>	SHOULD ANY OF THE ABOVE DESCRIBED POLICIES BE CANCELLED BEFORE THE EXPIRATION DATE THEREOF, NOTICE WILL BE DELIVERED IN ACCORDANCE WITH THE POLICY PROVISIONS
		AUTHORIZED REPRESENTATIVE  

© 1988-2015 ACORD CORPORATION. All rights reserved.



STATE OF NEW YORK  
WORKERS' COMPENSATION BOARD

**CERTIFICATE OF NYS WORKERS' COMPENSATION INSURANCE COVERAGE**

<p><b>1a. Legal Name &amp; Address of Insured (Use street address only)</b></p> <p>Visone Construction Inc 79 Sheldon Ave Depew, NY 14043</p> <p><i>Work Location of Insured (Only required if coverage is specifically limited to certain locations in New York State, i.e., a Wrap-Up Policy)</i></p>	<p><b>1b. Business Telephone Number of Insured</b></p> <p>(716)681-7331</p> <p><b>1c. NYS Unemployment Insurance Employer Registration Number of Insured</b></p> <p><b>1d. Federal Employer Identification Number of Insured or Social Security Number</b></p>
<p><b>2. Name and Address of the Entity Requesting Proof of Coverage (Entity Being Listed as the Certificate Holder)</b></p> <p>County of Erie 95 Franklin St Buffalo NY 14202</p> <div data-bbox="469 700 745 800" style="border: 1px solid black; padding: 5px; text-align: center;"> <p><b>APPROVED</b> <b>JULY 30 2024</b> AARON RUBIN ERIE COUNTY DEPARTMENT OF LAW</p> </div>	<p><b>3a. Name of Insurance Carrier</b></p> <p>CorePointe Ins Co</p> <p><b>3b. Policy Number of entity listed in box "1a"</b></p> <p>CPW1001934</p> <p><b>3c. Policy effective period</b></p> <p>12/31/2023 - 12/31/2024</p> <p><b>3d. The Proprietor, Partners or Executive Officers are</b> <input checked="" type="checkbox"/> <b>included.</b> (Only check box if all partners/officers included) <input type="checkbox"/> <b>all excluded or certain partners/officers excluded.</b></p>

This certifies that the insurance carrier indicated above in box "3" insures the business referenced above in box "1a" for workers' compensation under the New York State Workers' Compensation Law. (To use this form, New York (NY) must be listed under **Item 3A** on the INFORMATION PAGE of the workers' compensation insurance policy). The Insurance Carrier or its licensed agent will send this Certificate of Insurance to the entity listed above as the certificate holder in box "2".

*The Insurance Carrier will also notify the above certificate holder within 10 days IF a policy is canceled due to nonpayment of premiums or within 30 days IF there are reasons other than nonpayment of premiums that cancel the policy or eliminate the insured from the coverage indicated on this Certificate. (These notices may be sent by regular mail.) Otherwise, this Certificate is valid for one year after this form is approved by the insurance carrier or its licensed agent, or until the policy expiration date listed in box "3c", whichever is earlier.*

**Please Note:** Upon the cancellation of the workers' compensation policy indicated on this form, if the business continues to be named on a permit, license or contract issued by a certificate holder, the business must provide that certificate holder with a new Certificate of Workers' Compensation Coverage or other authorized proof that the business is complying with the mandatory coverage requirements of the New York State Workers' Compensation Law.

Under penalty of perjury, I certify that I am an authorized representative or licensed agent of the insurance carrier referenced above and that the named insured has the coverage as depicted on this form.

Approved by: MARK E. STAHLKA  
(Print name of authorized representative or licensed agent of insurance carrier)

Approved by:  July 18, 2024  
(Signature) (Date)

Title: PRESIDENT

Telephone Number of authorized representative or licensed agent of insurance carrier: 716-634-7070

**Please Note:** Only insurance carriers and their licensed agents are authorized to issue Form C-105.2. Insurance brokers are NOT authorized to issue it.

## Workers' Compensation Law

### Section 57. Restriction on issue of permits and the entering into contracts unless compensation is secured.

1. The head of a state or municipal department, board, commission or office authorized or required by law to issue any permit for or in connection with any work involving the employment of employees in a hazardous employment defined by this chapter, and notwithstanding any general or special statute requiring or authorizing the issue of such permits, shall not issue such permit unless proof duly subscribed by an insurance carrier is produced in a form satisfactory to the chair, that compensation for all employees has been secured as provided by this chapter. Nothing herein, however, shall be construed as creating any liability on the part of such state or municipal department, board, commission or office to pay any compensation to any such employee if so employed.

2. The head of a state or municipal department, board, commission or office authorized or required by law to enter into any contract for or in connection with any work involving the employment of employees in a hazardous employment defined by this chapter, notwithstanding any general or special statute requiring or authorizing any such contract, shall not enter into any such contract unless proof duly subscribed by an insurance carrier is produced in a form satisfactory to the chair, that compensation for all employees has been secured as provided by this chapter.





Workers' Compensation Board

## CERTIFICATE OF INSURANCE COVERAGE NYS DISABILITY AND PAID FAMILY LEAVE BENEFITS LAW

**PART 1. To be completed by NYS disability and Paid Family Leave benefits carrier or licensed insurance agent of that carrier**

<p>1a. Legal Name &amp; Address of Insured (use street address only)  <b>VISONE CONSTRUCTION INC</b>  <b>ATTN: SHELLEY VISONE</b>  <b>79 SHELDON AVENUE</b>  <b>DEPEW, NY 14043</b></p> <p><small>Work Location of Insured (Only required if coverage is specifically limited to certain locations in New York State, i.e., Wrap-Up Policy)</small></p>	<p>1b. Business Telephone Number of Insured  <b>716-759-1715</b></p> <p>1c. Federal Employer Identification Number of Insured or Social Security Number  <b>161320950</b></p>
<p>2. Name and Address of Entity Requesting Proof of Coverage (Entity Being Listed as the Certificate Holder)</p> <p><b>County of Erie</b>  <b>95 Franklin St</b>  <b>Buffalo NY 14202</b></p> <div style="border: 1px solid black; padding: 5px; text-align: center; margin: 10px auto; width: fit-content;"> <p><b>APPROVED</b>  <b>JULY 30 2024</b>  <small>AARON RUBIN</small>  <small>ERIE COUNTY DEPARTMENT OF LAW</small></p> </div>	<p>3a. Name of Insurance Carrier  <b>ShelterPoint Life Insurance Company</b></p> <p>3b. Policy Number of Entity Listed in Box "1a"  <b>DBL594859</b></p> <p>3c. Policy effective period  <b>01/01/2024</b> to <b>12/31/2025</b></p>

4. Policy provides the following benefits:

A. Both disability and paid family leave benefits.  
 B. Disability benefits only.  
 C. Paid family leave benefits only.

5. Policy covers:

A. All of the employer's employees eligible under the NYS Disability and Paid Family Leave Benefits Law.  
 B. Only the following class or classes of employer's employees:

---

Under penalty of perjury, I certify that I am an authorized representative or licensed agent of the insurance carrier referenced above and that the named insured has NYS Disability and/or Paid Family Leave Benefits insurance coverage as described above.

Date Signed 7/18/2024 By   
(Signature of insurance carrier's authorized representative or NYS Licensed Insurance Agent of that insurance carrier)

Telephone Number 516-829-8100 Name and Title Leston Welsh, Chief Executive Officer

**IMPORTANT:** If Boxes 4A and 5A are checked, and this form is signed by the insurance carrier's authorized representative or NYS Licensed Insurance Agent of that carrier, this certificate is COMPLETE. Mail it directly to the certificate holder.

If Box 4B, 4C or 5B is checked, this certificate is NOT COMPLETE for purposes of Section 220, Subd. 8 of the NYS Disability and Paid Family Leave Benefits Law. It must be emailed to PAU@wcb.ny.gov or it can be mailed for completion to the Workers' Compensation Board, Plans Acceptance Unit, PO Box 5200, Binghamton, NY 13902-5200.

**PART 2. To be completed by the NYS Workers' Compensation Board (Only if Box 4B, 4C or 5B have been checked)**

**State of New York**  
**Workers' Compensation Board**

According to information maintained by the NYS Workers' Compensation Board, the above-named employer has complied with the NYS Disability and Paid Family Leave Benefits Law (Article 9 of the Workers' Compensation Law) with respect to all of their employees.

Date Signed \_\_\_\_\_ By \_\_\_\_\_  
(Signature of Authorized NYS Workers' Compensation Board Employee)

Telephone Number \_\_\_\_\_ Name and Title \_\_\_\_\_

**Please Note:** Only insurance carriers licensed to write NYS disability and paid family leave benefits insurance policies and NYS licensed insurance agents of those insurance carriers are authorized to issue Form DB-120.1. **Insurance brokers are NOT authorized to issue this form.**



## Additional Instructions for Form DB-120.1

By signing this form, the insurance carrier identified in Box 3 on this form is certifying that it is insuring the business referenced in Box 1a for disability and/or Paid Family Leave benefits under the NYS Disability and Paid Family Leave Benefits Law. The insurance carrier or its licensed agent will send this Certificate of Insurance Coverage (Certificate) to the entity listed as the certificate holder in Box 2.

The insurance carrier must notify the above certificate holder and the Workers' Compensation Board within 10 days IF a policy is cancelled due to nonpayment of premiums or within 30 days IF there are reasons other than nonpayment of premiums that cancel the policy or eliminate the insured from coverage indicated on this Certificate. (These notices may be sent by regular mail.) Otherwise, this Certificate is valid for one year after this form is approved by the insurance carrier or its licensed agent, or until the policy expiration date listed in Box 3c, whichever is earlier.

This Certificate is issued as a matter of information only and confers no rights upon the certificate holder. This Certificate does not amend, extend or alter the coverage afforded by the policy listed, nor does it confer any rights or responsibilities beyond those contained in the referenced policy.

This Certificate may be used as evidence of a NYS disability and/or Paid Family Leave benefits contract of insurance only while the underlying policy is in effect.

**Please Note:** Upon the cancellation of the disability and/or Paid Family Leave benefits policy indicated on this form, if the business continues to be named on a permit, license or contract issued by a certificate holder, the business must provide that certificate holder with a new Certificate of Insurance Coverage for NYS disability and/or Paid Family Leave Benefits or other authorized proof that the business is complying with the mandatory coverage requirements of the NYS Disability and Paid Family Leave Benefits Law.

## NYS DISABILITY AND PAID FAMILY LEAVE BENEFITS LAW

### §220. Subd. 8

(a) The head of a state or municipal department, board, commission or office authorized or required by law to issue any permit for or in connection with any work involving the employment of employees in employment as defined in this article, and notwithstanding any general or special statute requiring or authorizing the issue of such permits, shall not issue such permit unless proof duly subscribed by an insurance carrier is produced in a form satisfactory to the chair, that the payment of disability benefits and after January first, two thousand and twenty-one, the payment of family leave benefits for all employees has been secured as provided by this article. Nothing herein, however, shall be construed as creating any liability on the part of such state or municipal department, board, commission or office to pay any disability benefits to any such employee if so employed.

(b) The head of a state or municipal department, board, commission or office authorized or required by law to enter into any contract for or in connection with any work involving the employment of employees in employment as defined in this article and notwithstanding any general or special statute requiring or authorizing any such contract, shall not enter into any such contract unless proof duly subscribed by an insurance carrier is produced in a form satisfactory to the chair, that the payment of disability benefits and after January first, two thousand eighteen, the payment of family leave benefits for all employees has been secured as provided by this article.



COUNTY OF ERIE

MARK C. POLONCARZ  
COUNTY EXECUTIVE

DIVISION OF PURCHASE

PERFORMANCE BOND

BOND NO HICNE-239-1041

KNOW ALL MEN BY THESE PRESENTS, that we, Visone Construction, Inc.  
of 79 Sheldon Avenue, Depew, NY 14043 (hereinafter called PRINCIPAL) and the Hudson Insurance Company  
a corporation of the State of Delaware having its principal office in  
the City of New York, NY and authorized to do business in the State of New York (hereinafter  
called SURETY) and held and firmly bound into the County of Erie New York  
(hereinafter called OBLIGEE), in the amount of Five Hundred Thousand and 00/100  
\$ 500,000.00 Dollars, lawful money of the United States of  
America, for the payment of which the PRINCIPAL and the SURETY hereby bind themselves, their heirs, executors,  
administrators, successors and assigns jointly and severally, firmly by these presents.

WHEREAS the above bounden PRINCIPAL has by written agreement dated July 8 ~~2023~~ 2024  
entered into a contract with the OBLIGEE for \$ Five Hundred Thousand and 00/100 Dollars  
\$500,000.00 which contract and documents included therein by reference made a part  
hereof (hereinafter called CONTRACT), covering the following project  
Bid No. 230311-022 Sanitary Sewer Open Cut Repair

(Describe Project)

NOW, THEREFORE, the condition of this obligation is such that if the PRINCIPAL shall



1. well and truly perform and fulfill all the undertakings, covenants, terms, conditions and agreements of said Contract during the original term of said Contract and any extensions thereof that may be granted by the OBLIGEE, with or without notice to the SURETY, and during the life of any guarantee required under the Contract, and shall also well and truly perform and fulfill all the undertakings, covenants, terms, conditions and agreements of any and all modifications of said Contract that may hereafter be made, with or without notice to the SURETY.
2. promptly make payment to all persons having a direct Contract with the PRINCIPAL or with a subcontractor of the PRINCIPAL supplying labor and material in the prosecution of the work provided for in said Contract and any and all modifications of said Contract that may hereinafter be made, notice of which modifications to the SURETY being hereby waived

then this obligation shall be void otherwise to remain in full force and effect

PROVIDED, HOWEVER, and this bond is executed and accepted upon the following express conditions:

1. That all persons who have supplied labor and material as aforesaid shall have a direct right of action hereunder against the PRINCIPAL and the SURETY, subject, however, to the prior right of the OBLIGEE to recover hereunder on account of any loss or damage caused to it by the failure of the PRINCIPAL to perform the Contract as aforesaid.
2. The SURETY for value received hereby stipulates and agrees, if requested to do so by the OBLIGEE, to fully perform and complete the work and furnish the materials mentioned and described in said Contract pursuant to terms, conditions and covenants thereof, if for any cause said PRINCIPAL fails or neglects to so fully perform said work, the said SURETY further agrees to commence said work of completion twenty (20) days after notice thereof from the OBLIGEE.
3. That the OBLIGEE shall notify the SURETY by registered letter addressed and mailed to its Home Office, of any breach of said Contract within sixty (60) days after such breach shall have come to the knowledge of the OBLIGEE. (Owner)
4. That the SURETY shall not be liable hereunder for any damage or compensation recoverable under any Worker's Compensation or Employer's Liability Statute.
5. That no suit, action or proceeding for loss or damage caused by a breach of any of the conditions of this bond shall be brought against the SURETY by the OBLIGEE after one (1) year from the day of final acceptance of the work by the Owner.
6. That no suit, action or proceeding for loss caused by the failure of the PRINCIPAL to pay all persons supplying labor and material in the prosecution of the work under said Contract shall be brought against the SURETY after six (6) months from the day on which final payment of the Contract is made.

Signed, sealed and dated this 18th day of July 20 24

Visone Construction, Inc.  
(PRINCIPAL)  
By   
President, ~~Vice President, Secretary, Treasurer~~ David Visone  
Hudson Insurance Company (SEAL)  
(SURETY)  
By:   
Scott C. Mahorsky, Attorney-in-Fact

EXECUTED POWERS OF ATTORNEY TO BE SUBMITTED WITH PERFORMANCE BOND

ACKNOWLEDGEMENT, IF A CORPORATION

STATE OF NY

COUNTY OF Erie

On this 22<sup>nd</sup> day of July, 2024 before me personally came David Visone to me known to be the person duly sworn, did depose and say, that he/she resides in Depew, NY. That he/she is **President** of corporation described in and which executed the foregoing instrument; that he/she knew the seal of said corporation; that the seal affixed to said instrument was such corporate seal; that it was affixed by order of the Board of Directors of said corporation, and that he/she signed his/her name thereto by like order.

Sworn before me the date set forth above

Anthony Majka 2/28/28

Notary Public

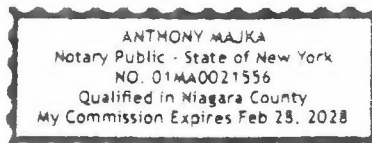

SURETY ACKNOWLEDGMENT

STATE OF PENNSYLVANIA )  
 ) SS  
COUNTY OF Montgomery )

On this 18th day of July, in the year 2024 before me  
Kimberly G. Rively, a Notary Public in and for said state, personally appeared  
Scott C. Mahorsky Attorney in Fact for Hudson Insurance Company,  
known to me to be the person who executed the within bond on behalf of the said corporation, and being fully  
sworn did duly acknowledge to me that such corporation executed the same for the purposes therein stated.

In Testimony Whereof I have set my hand and affixed my official seal, the day and year stated in the  
certificate above.

  
NOTARY PUBLIC Kimberly G. Rively

My Commission Expires: July 13, 2025

Commonwealth of Pennsylvania - Notary Seal  
KIMBERLY G. RIVELY, Notary Public  
Montgomery County  
My Commission Expires July 13, 2025  
Commission Number 1058022

State of New York

DEPARTMENT OF FINANCIAL SERVICES

WHEREAS IT APPEARS THAT

Hudson Insurance Company

Home Office Address Wilmington, Delaware

Organized under the Laws of Delaware

has complied with the necessary requirements of or pursuant to law, it is hereby

licensed to do within this State the business of

accident and health, fire, miscellaneous property, water damage, burglary and theft, glass, boiler and machinery, elevator, animal, collision, personal injury liability, property damage liability, workers' compensation and employers' liability, fidelity and surety, credit, motor vehicle and aircraft physical damage, marine and inland marine, marine protection and indemnity, service contract reimbursement and legal services insurance, as specified in paragraph(s) 3, 4, 5, 6, 7, 8, 9, 10, 11, 12, 13, 14, 15, 16, 17, 19, 20, 21, 28 and 29 of Section 1113(a) of the New York Insurance Law and also such workers' compensation insurance as may be incident to coverages contemplated under paragraphs 20 and 21 of Section 1113(a), including insurances described in the Longshoremen's and Harbor Workers' Compensation Act (Public Law No. 803, 69 Cong. as amended; 33 USC Section 901 et seq. as amended) to the extent permitted by certified copy of its charter document on file in this Department until July 1, 2023



In Witness Whereof, I have hereunto set  
my hand and affixed the official seal of this  
Department at the City of Albany, New York, this  
1st day of July, 2022

Adrienne A. Harris  
Superintendent

By

Colleen M. Draper  
Special Deputy Superintendent

Original on Watermarked Paper





HICNE-239-1041

POWER OF ATTORNEY

KNOW ALL MEN BY THESE PRESENTS: That HUDSON INSURANCE COMPANY, a corporation of the State of Delaware, with offices at 100 William Street, New York, New York, 10038, has made, constituted and appointed, and by these presents, does make, constitute and appoint

Scott C. Mahorsky, Richard V. Dobbs, Christine A. Hartung
of the State of Pennsylvania

its true and lawful Attorney(s)-in-Fact, at New York, New York, each of them alone to have full power to act without the other or others, to make, execute and deliver on its behalf, as Surety, bonds and undertakings given for any and all purposes, also to execute and deliver on its behalf as aforesaid renewals, extensions, agreements, waivers, consents or stipulations relating to such bonds or undertakings provided, however, that no single bond or undertaking shall obligate said Company for any portion of the penal sum thereof in excess of the sum of Twenty Five Million Dollars (\$25,000,000.00).

Such bonds and undertakings when duly executed by said Attorney(s)-in-Fact, shall be binding upon said Company as fully and to the same extent as if signed by the President of said Company under its corporate seal attested by its Secretary.

In Witness Whereof, HUDSON INSURANCE COMPANY has caused these presents to be of its Senior Vice President thereunto duly authorized, on this 9th day of June, 2023 at New York, New York.

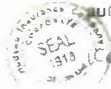

(Corporate seal)

Attest
Dina Daskalakis No. 01MU6067553
Corporate Secretary

HUDSON INSURANCE COMPANY

By Michael P. Cifone
Senior Vice President

STATE OF NEW YORK
COUNTY OF NEW YORK SS

On the 9th day of June, 2023 before me personally came Michael P Cifone to me known, who being by me duly sworn did depose and say that he is a Senior Vice President of HUDSON INSURANCE COMPANY, the corporation described herein and which executed the above instrument, that he knows the seal of said Corporation, that the seal affixed to said instrument is such corporate seal, that it was so affixed by order of the Board of Directors of said Corporation, and that he signed his name thereto by like order.

(Notarial Seal)



ANN M. MURPHY
Notary Public, State of New York
No. 01MU6067553
Qualified in Nassau County
Commission Expires December 10, 2025

CERTIFICATION

STATE OF NEW YORK
COUNTY OF NEW YORK SS.

The undersigned Dina Daskalakis hereby certifies

That the original resolution, of which the following is a true and correct copy, was duly adopted by unanimous written consent of the Board of Directors of Hudson Insurance Company dated July 27th, 2007, and has not since been revoked, amended or modified:

"RESOLVED, that the President, the Executive Vice Presidents, the Senior Vice Presidents and the Vice Presidents shall have the authority and discretion, to appoint such agent or agents, or attorney or attorneys-in-fact, for the purpose of carrying on this Company's surety business, and to empower such agent or agents, or attorney or attorneys-in-fact, to execute and deliver, under this Company's seal or otherwise, bonds obligations, and recognizances, whether made by this Company as surety thereon or otherwise, indemnity contracts, contracts and certificates, and any and all other contracts and undertakings made in the course of this Company's surety business, and renewals, extensions, agreements, waivers, consents or stipulations regarding undertakings so made, and

FURTHER RESOVLED, that the signature of any such Officer of the Company and the Company's seal may be affixed by facsimile to any power of attorney or certification given for the execution of any bond, undertaking, recognizance, contract of indemnity or other written obligation in the nature thereof or related thereto, such signature and seal when so used whether heretofore or hereafter, being hereby adopted by the Company as the original signature of such officer and the original seal of the Company, to be valid and binding upon the Company with the same force and effect as though manually affixed"

THAT the above and foregoing is a full, true and correct copy of Power of Attorney issued by said Company, and of the whole of the original and that the said Power of Attorney is still in full force and effect and has not been revoked, and furthermore that the Resolution of the Board of Directors, set forth in the said Power of Attorney is now in force

Witness the hand of the undersigned and the seal of said Corporation this 18th day of July, 2024

(Corporate seal)



By Dina Daskalakis
Dina Daskalakis, Corporate Secretary



**HUDSON INSURANCE COMPANY**  
**SHORT FORM FINANCIAL STATEMENT**  
**AS OF DECEMBER 31, 2023**

**ASSETS**

Bonds	\$	213,611,946
Preferred stocks		55,803,393
Common stocks		340,719,956
Mortgage Loans on Real Estate		277,383,791
Cash on hand and on deposit		47,025,622
Reinsurance Receivable		443,991,074
FIT recoverable (including net deferred tax asset)		25,895,640
Aggregate write-ins for other than invested assets		47,792,231
Uncollected premiums and agents' balances in the course of collection		26,458,746
Deferred premiums, agents' balances and installments booked but deferred and not yet due (including earned but unbilled premiums)		158,459,785
Other Assets		<u>735,770,807</u>
Total Assets	\$	<u><u>2,372,912,991</u></u>

**LIABILITIES & SURPLUS**

Losses	\$	397,207,040
Loss adjustment expense		39,537,629
Other expenses		34,149,978
Unearned Premiums		135,530,274
Ceded reinsurance premiums payable		877,185,803
Payable to parent, subsidiaries and affiliates		9,761,021
Commissions payable, contingent commissions and other similar charges		63,322,383
Other Liabilities		<u>136,330,908</u>
Total Liabilities	\$	<u>1,693,025,036</u>
Preferred and Common capital stock	\$	7,500,238
Gross paid in and contributed surplus		293,480,097
Unassigned funds (surplus)		<u>378,907,620</u>
Surplus as regards policyholders	\$	<u>679,887,955</u>
Total Liabilities and Surplus	\$	<u><u>2,372,912,991</u></u>

STATE OF NEW YORK )  
) ss  
COUNTY OF NEW YORK )

I, Rory Rose, the undersigned Chief Financial Officer of Hudson Insurance Company hereby certify the foregoing to be a short form financial statement in the form of a balance sheet, showing the Company's assets and liabilities on a provisional basis, at the close of business on December 31, 2023.

IN TESTIMONY WHEREOF, I have set my hand and affixed the seal of the Company, this 21 day of March, 2024

*Rory Rose*  
\_\_\_\_\_  
Rory Rose  
Chief Financial Officer

Subscribed and sworn to before me this 21 day of March, 2024  
My commission expires \_\_\_\_\_

ANN M. MURPHY  
Notary Public, State of New York  
No. 01MU6067553  
Qualified in Nassau County, Certified in New York  
Commission Expires December 10, 2025

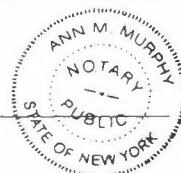

NEW YORK STATE PREVAILING WAGE

\*On contracts which are subject to New York Department of Labor Prevailing Wage laws and regulations, the contractor is required to submit certified payroll record every thirty (30) days after the issuance of your first payroll under this contract. Required forms are available at the New York Department of Labor's website <https://www.labor.state.ny.us/formsdocs/wp/pw12.pdf>.

This project's PRC# 2023012974.

In addition, if applicable, contractor is required to attach a copy of proof of completion of the OSHA 10 course to the first certified payroll submitted and on each succeeding payroll where any new or additional employee is first listed.

Records are to be submitted as directed in your award letter.

Failure to submit the legally required records will result in delayed payments.

CONFINED SPACE PROGRAM CERTIFICATION

This is to certify that Visone Construction, Inc has  
(Company Name)

Established a Confined Space Program which conforms to OSHA 29 CFR Part 1910, as it may be amended. Furthermore, it is understood that full implementation of the contractor's Confined Space Program is a requirement of this contract.

By: David Visone  
Contractor's Signature

David Visone  
Typed or Printed Name

President  
Title

Visone Construction, Inc.  
Business Name

79 Sheldon Ave  
Deerfield, NY 14123  
Business Address

Certification Regarding Debarment And Suspension

1) As required by Federal Executive Order 12549, and prescribed by federal regulations, including 48 C.F.R. Subpart 9.4, the Contractor certifies that it, and its principals:

(a) Are not presently disbarred, suspended, proposed for debarment, declared ineligible or voluntarily excluded by any Federal department or agency;

(b) Have not within a 3-year period preceding this proposal been convicted of or had a civil judgment rendered against them for commission of fraud or a criminal offense in connection with obtaining, attempting to obtain, or performing a public (Federal, State or local) transaction or contract under a public transaction, including any violation of Federal or State antitrust statutes or commission of embezzlement, theft, forgery, bribery, falsification or destruction of records, making false statements, or receiving stolen property;

(c) Are not presently indicted for or otherwise criminally or civilly charged by a Government entity (Federal, State or local) with commission of any of the offenses enumerated in paragraph (b) above; and

(d) Have not within a 3-year period preceding this application/proposal had one or more public transactions (Federal, State or local) terminated for cause or default.

2) Where the Contractor is unable to certify to any of the statements in this paragraph, the Contractor shall attach an explanation to this certification.

Date: 1/11/20

[Handwritten Signature]  
Signature

President  
Title

Vision Construction, Inc  
Business Name

**Certification Regarding Drug-Free Workplace Requirements Grantees Other Than Individuals**

This certification is required by regulations implementing Sections 5151-5160 of the Drug-Free Workplace Act of 1988, 41 U.S.C. § 701 et seq. See 48 C.F.R. Subpart 23.5.

The Contractor certifies that it will provide a drug-free workplace by:

(a) Publishing a statement notifying employees that the unlawful manufacture, distribution, dispensing, possession or use of a controlled substance is prohibited in the grantee's workplace and specifying the actions that will be taken against employees for violation of such prohibition;

(b) Establishing a drug-free awareness program to inform employees about:

- (1) The dangers of drug abuse in the workplace;
- (2) The grantee's policy of maintaining a drug-free workplace;
- (3) Any available drug counseling, rehabilitation, and employee assistance programs; and,

(4) The penalties that may be imposed upon employees for drug abuse violations occurring in the workplace;

(c) Making it a requirement that each employee to be engaged in the performance of the grant be given a copy of the statement required by paragraph (a);

(d) Notifying the employee in the statement required by paragraph (a) that, as a condition of employment under the grant, the employee will:

(1) Abide by the terms of the statement; and,

(2) Notify the employer of any criminal drug statute conviction for a violation occurring in the workplace no later than five days after such conviction;

(e) Notifying the agency within ten days after receiving notice under subparagraph (d)(2) from an employee or otherwise receiving actual notice of such conviction;

(f) Taking one of the following actions, within 30 days of receiving notice under subparagraph (d)(2), with respect to any employee who is so convicted:

(1) Taking appropriate personnel action against such an employee, up to and including termination; or

(2) Requiring such employee to participate satisfactorily in a drug abuse assistance or rehabilitation program approved for such purposes by a Federal, State or local health, law enforcement, or other appropriate agency;

(g) Making a good faith effort to continue to maintain a drug-free workplace through implementation of paragraph (a), (b), (c), (d), (e) and (f).

Date: 1/11/22

[Signature]  
Signature  
President  
Title  
U.S. Corp Construction Inc  
Business Name

**Certification Regarding Lobbying Certification for Contracts, Grants, Loans, and Cooperative Agreements**

The undersigned certifies, to the best of his or her knowledge and belief, that:

(1) No Federal appropriated funds have been paid or will be paid, by or on behalf of the undersigned, to any person for influencing or attempting to influence an officer or employee of any agency, a Member of Congress, an officer or employee of Congress, or an employee of a Member or Congress in connection with the awarding of any Federal contract, the making of any Federal grant, the making of any Federal loan, the entering into of any cooperative agreement, and the extension, continuation, renewal, amendment, or modification of any Federal contract, grant, loan, or cooperative agreement.

(2) If any funds other than Federal appropriated funds have been paid or will be paid to any person for influencing or attempting to influence an officer or employee of any agency, A Member of Congress, an officer or employee of Congress, or an employee of a Member of Congress in connection with this Federal contract, grant, loan or cooperative agreement, the undersigned shall complete and submit Standard Form-LLL, "Disclosure Form to Report Lobbying," in accordance with its instructions.

(3) The undersigned shall require that the language of this certification be included in the award documents for all subawards at all tiers (including subcontracts, subgrants, and contracts under grants, loans, and cooperative agreements) and that all subrecipients shall certify and disclose accordingly.

This certification is a material representation of fact upon which reliance was placed when this transaction was made or entered into. Submission of this certification is a prerequisite for making or entering into this transaction imposed by 31 U.S.C. § 1352. Any person who fails to file the required certification shall be subject to a civil penalty of not less than \$10,000 and not more than \$100,000 for each such failure.

Date: 1/11/24

[Handwritten Signature]  
Signature

President  
Title

Visone Construction, Inc  
Business Name

**NOTE:** If Disclosure Forms are required, please contact: Mr. Will Sexton, Deputy Director, Grants and Contracts Management Division, Room 341F, HHH Building, 200 Independence Avenue, SW, Washington, D.C. 20201-0001



# ADDITIONAL INSTRUCTIONS TO BIDDERS

## TABLE OF CONTENTS

	Page
Article 1— Defined Terms.....	2
Article 2— Bidding Documents.....	2
Article 3— Qualifications of Bidders.....	2
Article 4— Pre-Bid Conference.....	3
Article 5— Site and Other Areas; Existing Site Conditions; Examination of Site; Owner’s Safety Program; Other Work at the Site.....	3
Article 6— Bidder’s Representations and Certifications.....	4
Article 7— Interpretations and Addenda.....	4
Article 8— Bid Security.....	4
Article 9— Contract Times.....	5
Article 10— Substitute and “Or Equal” Items.....	5
Article 11— Subcontractors, Suppliers, and Others.....	5
Article 12— Preparation of Bid.....	5
Article 13— Basis of Bid.....	6
Article 14— Submittal of Bid.....	7
Article 15— Modification and Withdrawal of Bid.....	7
Article 16— Opening of Bids.....	7
Article 17— Bids to Remain Subject to Acceptance.....	7
Article 18— Evaluation of Bids and Award of Contract.....	7
Article 19— Bonds and Insurance.....	7
Article 20— Signing of Agreement.....	7
Article 21— Exemption from Sales and Compensating Use Taxes.....	7
Article 22— Statutory and Funding-Financing Requirements.....	7
Article 23— Procurement Contract to be Assigned.....	<b>Error! Bookmark not defined.</b>

---

### 00 21 13, Instructions to Bidders

This document is a MODIFIED version of EJCDC® C-200, Copyright© 2018 by the National Society of Professional Engineers, American Council of Engineering Companies, and American Society of Civil Engineers, or is based in part on excerpts from copyrighted EJCDC documents. All rights reserved. Those portions of the text that originated in copyrighted EJCDC documents remain subject to the copyright.



## **ARTICLE 1—DEFINED TERMS**

- 1.01 Terms used in these Instructions to Bidders have the meanings indicated in the General Conditions and Supplementary Conditions.

## **ARTICLE 2—BIDDING DOCUMENTS**

- 2.01 Bidder shall obtain a complete set of Bidding Requirements and proposed Contract Documents (together, the Bidding Documents). See the Invitation to Bid for a list of the Contract Documents. It is Bidder's responsibility to determine that it is using a complete set of documents in the preparation of a Bid. Bidder assumes sole responsibility for errors or misinterpretations resulting from the use of incomplete documents, by Bidder itself or by its prospective Subcontractors and Suppliers.
- 2.02 Bidding Documents are made available for the sole purpose of obtaining Bids for completion of the Project and permission to download or distribution of the Bidding Documents does not confer a license or grant permission or authorization for any other use. Authorization to download documents, or other distribution, includes the right for plan holders to print documents solely for their use, and the use of their prospective Subcontractors and Suppliers, provided the plan holder pays all costs associated with printing or reproduction. Printed documents may not be re-sold under any circumstances.
- 2.03 *Electronic Documents*
- A. Bidding Documents will be provided in Adobe PDF (Portable Document Format) (.pdf) that is readable by Adobe Acrobat products.
  - B. Unless otherwise stated in the Bidding Documents, the Bidder may use and rely upon complete sets of Electronic Documents of the Bidding Documents, described in Paragraph 2.04.A above. However, Bidder assumes all risks associated with differences arising from transmission/receipt of Electronic Documents versions of Bidding Documents and reproductions prepared from those versions and, further, assumes all risks, costs, and responsibility associated with use of the Electronic Documents versions to derive information that is not explicitly contained in printed paper versions of the documents, and for Bidder's reliance upon such derived information.

## **ARTICLE 3—QUALIFICATIONS OF BIDDERS**

- 3.01 Erie County Local Law No. 2-2021 requires the use of the New York State Vendor Responsibility For-Profit Construction (Form CCA-2) and Attachments which is available at

---

### **00 21 13, Instructions to Bidders**

This document is a MODIFIED version of EJCDC® C-200, Copyright© 2018 by the National Society of Professional Engineers, American Council of Engineering Companies, and American Society of Civil Engineers, or is based in part on excerpts from copyrighted EJCDC documents. All rights reserved. Those portions of the text that originated in copyrighted EJCDC documents remain subject to the copyright.

<https://www.osc.state.ny.us/state-vendors/vendrep/file-your-vendor-responsibility-questionnaire>. A hard copy of this form must be submitted with the Bid.

- 3.02 A Bidder's failure to submit required qualification information may disqualify Bidder from receiving an award of the Contract.
- 3.03 No requirement in this Article 3 to submit information will prejudice the right of Owner to seek additional pertinent information regarding Bidder's qualifications.
- 3.04 Bidder's attention is directed to County of Erie Local Law No. 2 (2021) in Section 00 73 75 Local Agency Requirements for more information related to Bidder qualifications.

#### **ARTICLE 4—PRE-BID CONFERENCE**

- 4.01 A non-mandatory pre-bid conference will be held at the time and location indicated. Representatives of Owner and Engineer will be present to discuss the Project. Bidders are encouraged to attend and participate in the conference; however, attendance at this conference is not required to submit a Bid.
- 4.02 Information presented at the pre-Bid conference does not alter the Contract Documents. Owner will issue Addenda to make any changes to the Contract Documents that result from discussions at the pre-Bid conference. Information presented, and statements made at the pre-bid conference will not be binding or legally effective unless incorporated in an Addendum.

#### **ARTICLE 5—SITE AND OTHER AREAS; EXISTING SITE CONDITIONS; EXAMINATION OF SITE; OWNER'S SAFETY PROGRAM; OTHER WORK AT THE SITE**

- 5.01 *Site and Other Areas*
  - A. The Site will be identified in individual Work Orders. By definition, the Site includes rights-of-way, easements, and other lands furnished by Owner for the use of the Contractor. Any additional lands required for temporary construction facilities, construction equipment, or storage of materials and equipment, and any access needed for such additional lands, are to be obtained and paid for by Contractor.
  - B. At the time of bid, Site locations have not been identified yet. Reports of explorations, tests of subsurface conditions, technical data or drawings will be provided to the Contractor as applicable to individual Work Orders.
- 5.02 *Existing Site Conditions: Not Used*
- 5.03 *Other Site-related Documents: Not Used*
- 5.04 *Site Visit and Testing by Bidders: Not Used*
- 5.05 *Owner's Safety Program*
  - A. Site visits and work at the Site may be governed by an Owner safety program which is in the Specifications.

---

#### **00 21 13, Instructions to Bidders**

This document is a MODIFIED version of EJCDC® C-200, Copyright© 2018 by the National Society of Professional Engineers, American Council of Engineering Companies, and American Society of Civil Engineers, or is based in part on excerpts from copyrighted EJCDC documents. All rights reserved. Those portions of the text that originated in copyrighted EJCDC documents remain subject to the copyright.

5.06 *Other Work at the Site: Not Used*

#### **ARTICLE 6—BIDDER’S REPRESENTATIONS AND CERTIFICATIONS**

6.01 *Express Representations and Certifications in Bid Form, Agreement*

- A. The Bid Form that each Bidder will submit contains express representations regarding the Bidder’s examination of Project documentation, and preparation of the Bid, and certifications regarding lack of collusion or fraud in connection with the Bid. Bidder should review these representations and certifications, and assure that Bidder can make the representations and certifications in good faith, before executing and submitting its Bid.
- B. If Bidder is awarded the Contract, Bidder (as Contractor) will make similar express representations and certifications when it executes the Agreement.

#### **ARTICLE 7—INTERPRETATIONS AND ADDENDA**

- 7.01 Owner on its own initiative may issue Addenda to clarify, correct, supplement, or change the Bidding Documents.
- 7.02 Bidder shall submit all questions about the meaning or intent of the Bidding Documents to Engineer in writing to Nadine Wetzel at nadine.wetzel@erie.gov.
- 7.03 Interpretations or clarifications considered necessary by Owner in response to such questions will be issued by Addenda delivered to all registered plan holders not later than three days prior to the date fixed for the opening of bids. Questions received less than six calendar days prior to the date for opening of Bids may not be answered.
- 7.04 Only responses set forth in an Addendum will be binding. Oral and other interpretations or clarifications will be without legal effect. Responses to questions are not part of the Contract Documents unless set forth in an Addendum that expressly modifies or supplements the Contract Documents.

#### **ARTICLE 8—BID SECURITY**

- 8.01 A Bid must be accompanied by Bid security made payable to Owner in an amount not less than \$10,000 and in the form of a Bid Bond issued by a Surety meeting the requirements of Paragraph 6.01 of the General Conditions. Such Bid Bond will be issued in the form included in the Bidding Documents.
- 8.02 The Bid security of the apparent Successful Bidder will be retained until Owner awards the contract to such Bidder, and such Bidder has executed the Contract, furnished the required Contract security, and met the other conditions of the Notice of Award, whereupon the Bid security will be released. If the Successful Bidder fails to execute and deliver the Contract and furnish the required Contract security within 15 days after the Notice of Award, Owner may consider Bidder to be in default, annul the Notice of Award, and the Bid security of that Bidder will be forfeited to the extent of Owner’s damages. Such forfeiture will be Owner’s exclusive remedy if Bidder defaults.
- 8.03 The Bid security of other Bidders that Owner believes to have a reasonable chance of receiving the award may be retained by Owner until the earlier of 7 days after the Effective Date of the

---

**00 21 13, Instructions to Bidders**

This document is a MODIFIED version of EJCDC® C-200, Copyright© 2018 by the National Society of Professional Engineers, American Council of Engineering Companies, and American Society of Civil Engineers, or is based in part on excerpts from copyrighted EJCDC documents. All rights reserved. Those portions of the text that originated in copyrighted EJCDC documents remain subject to the copyright.

Contract or 46 days after the Bid opening, whereupon Bid security furnished by such Bidders will be released.

- 8.04 Bid security of other Bidders that Owner believes do not have a reasonable chance of receiving the award will be released within 10 business days after the Bid opening.

#### **ARTICLE 9—CONTRACT TIMES**

- 9.01 The number of days within which, or the dates by which, the Work is to be (a) substantially completed and (b) ready for final payment, and (c) Milestones (if any) are to be achieved, are set forth in the Agreement.
- 9.02 Provisions for liquidated damages, if any, for failure to timely attain a Milestone, Substantial Completion, or completion of the Work in readiness for final payment, are set forth in the Agreement.

#### **ARTICLE 10—SUBSTITUTE AND “OR EQUAL” ITEMS**

- 10.01 The Contract for the Work, as awarded, will be on the basis of materials and equipment specified or described in the Bidding Documents without consideration during the bidding and Contract award process of possible substitute or “or-equal” items. In cases in which the Contract allows the Contractor to request that Engineer authorize the use of a substitute or “or-equal” item of material or equipment, such application will not be considered by Engineer until after the Effective Date of the Contract
- 10.02 All prices that Bidder sets forth in its Bid will be based on the presumption that the Contractor will furnish the materials and equipment specified or described in the Bidding Documents, as supplemented by Addenda. Any assumptions regarding the possibility of post-Bid approvals of “or-equal” or substitution requests are made at Bidder’s sole risk.

#### **ARTICLE 11—SUBCONTRACTORS, SUPPLIERS, AND OTHERS**

- 11.01 The apparent Successful Bidder, and any other Bidder so requested, may be required submit to Owner a list of the Subcontractors or Suppliers of major equipment proposed for the Work, as requested, for each Work Order.
- 11.02 Any limitations on the amount of Work that can be subcontracted are included in SC 7.07.A.1.

#### **ARTICLE 12—PREPARATION OF BID**

- 12.01 The Bid Form is included with the Bidding Documents.
- A. All blanks on the Bid Form must be completed in ink and the Bid Form signed in ink. Erasures or alterations must be initialed in ink by the person signing the Bid Form. A Bid price must be indicated for each section, Bid item, alternate, adjustment unit price item, and unit price item listed therein.
- B. If the Bid Form expressly indicates that submitting pricing on a specific alternate item is optional, and Bidder elects to not furnish pricing for such optional alternate item, then Bidder may enter the words “No Bid” or “Not Applicable.”

---

#### **00 21 13, Instructions to Bidders**

This document is a MODIFIED version of EJCDC® C-200, Copyright© 2018 by the National Society of Professional Engineers, American Council of Engineering Companies, and American Society of Civil Engineers, or is based in part on excerpts from copyrighted EJCDC documents. All rights reserved. Those portions of the text that originated in copyrighted EJCDC documents remain subject to the copyright.

- 12.02 Bidder shall prepare its Bid on a paper copy of the Bid Form printed from the Electronic Documents version of the Bidding Documents. The printed copy of the Bid Form must be clearly legible, printed on 8½ inch by 11-inch paper and as closely identical in appearance to the Electronic Document version of the Bid Form as may be practical. The Owner reserves the right to accept Bid Forms which nominally vary in appearance from the original paper version of the Bid Form, providing that all required information and submittals are included with the Bid.
- 12.03 A Bid by a corporation must be executed in the corporate name by a corporate officer (whose title must appear under the signature), accompanied by evidence of authority to sign. The corporate address and state of incorporation must be shown.
- 12.04 A Bid by a partnership must be executed in the partnership name and signed by a partner (whose title must appear under the signature), accompanied by evidence of authority to sign. The official address of the partnership must be shown.
- 12.05 A Bid by a limited liability company must be executed in the name of the firm by a member or other authorized person and accompanied by evidence of authority to sign. The state of formation of the firm and the official address of the firm must be shown.
- 12.06 A Bid by an individual must show the Bidder's name and official address.
- 12.07 A Bid by a joint venture must be executed by an authorized representative of each joint venturer in the manner indicated on the Bid Form. The joint venture must have been formally established prior to submittal of a Bid, and the official address of the joint venture must be shown.
- 12.08 All names must be printed in ink below the signatures.
- 12.09 The Bid must contain an acknowledgment of receipt of all Addenda, the numbers of which must be filled in on the Bid Form.
- 12.10 Postal and e-mail addresses and telephone number for communications regarding the Bid must be shown.
- 12.11 The Bid must contain evidence of Bidder's authority to do business in New York State, or Bidder must certify in writing that it will obtain such authority within the time for acceptance of Bids and attach such certification to the Bid.

#### **ARTICLE 13—BASIS OF BID**

- 13.01 *Unit Price*
  - A. Bidders must submit a Bid on a unit price basis for each item of Work listed in the unit price section of the Bid Form.
  - B. The "Bid Price" (sometimes referred to as the extended price) for each unit price Bid item will be the product of the "Estimated Quantity", which Owner or its representative has set forth in the Bid Form, for the item and the corresponding "Bid Unit Price" offered by the Bidder. The total of all unit price Bid items will be the sum of these "Bid Prices"; such total will be used by Owner for Bid comparison purposes. The final quantities and Contract Price will be determined in accordance with Paragraph 13.03 of the General Conditions.
  - C. Discrepancies between the multiplication of units of Work and unit prices will be resolved in favor of the unit prices. Discrepancies between the indicated sum of any column of figures and the correct sum thereof will be resolved in favor of the correct sum.

---

#### **00 21 13, Instructions to Bidders**

This document is a MODIFIED version of EJCDC® C-200, Copyright© 2018 by the National Society of Professional Engineers, American Council of Engineering Companies, and American Society of Civil Engineers, or is based in part on excerpts from copyrighted EJCDC documents. All rights reserved. Those portions of the text that originated in copyrighted EJCDC documents remain subject to the copyright.

**ARTICLE 14—SUBMITTAL OF BID** *NOT USED – REFER TO INVITATION TO BID*

**ARTICLE 15—MODIFICATION AND WITHDRAWAL OF BID** *NOT USED – REFER TO INVITATION TO BID*

**ARTICLE 16—OPENING OF BIDS** *NOT USED – REFER TO INVITATION TO BID*

**ARTICLE 17—BIDS TO REMAIN SUBJECT TO ACCEPTANCE** *NOT USED – REFER TO INVITATION TO BID*

**ARTICLE 18—EVALUATION OF BIDS AND AWARD OF CONTRACT** *NOT USED – REFER TO INVITATION TO BID*

**ARTICLE 19—BONDS AND INSURANCE** *NOT USED – REFER TO INVITATION TO BID*

**ARTICLE 20—SIGNING OF AGREEMENT** *NOT USED – REFER TO INVITATION TO BID*

**ARTICLE 21—EXEMPTION FROM SALES AND COMPENSATING USE TAXES**

21.01 In computing their bids, Bidders are not to include the sales and compensating use taxes of the State of New York or of any city and county in the State of New York for any supplies or materials to be sold to the Owner, which is exempt from such taxes.

**ARTICLE 22— STATUTORY AND FUNDING-FINANCING REQUIREMENTS**

22.01 Bidders' attention is directed to the following Sections:

- A. 00 73 36, Equal Employment Opportunity Requirements;
- B. 00 73 38, Apprenticeship Requirements;
- C. 00 73 39, Minority Business Enterprise Requirements;
- D. 00 73 40, Disadvantaged Worker Requirements.
- E. 00 73 43, Wage Rate Requirements; and
- F. 00 73 75, Local Agency Requirements.

22.02 With the Bid, within 3 days of the Bid Opening, or at Owner's request, the three (3) lowest Bidders must submit Minority Business Enterprises documentation if Section 00 73 39 Minority Business Enterprise Requirements is included.

22.03 **ERIE COUNTY EXECUTIVE ORDER #18:** The project contemplated by this Request for Bids may be subject to Erie County Executive Order #18 which is attached hereto along with its Rules and Regulations for reference as Section 00 73 40 Articles 1 and 2. **All bids must include a verified attestation of intent to comply and statement of work force. Such attestation and statement is attached hereto as Erie County Executive Order #18 Attestation and Statement of Workforce in Section 00 73 40. Any bids received which do not include such attestation or include an incomplete attestation may be deemed non-responsive.** Be advised that the Contractor will be

---

**00 21 13, Instructions to Bidders**

This document is a MODIFIED version of EJCDC® C-200, Copyright© 2018 by the National Society of Professional Engineers, American Council of Engineering Companies, and American Society of Civil Engineers, or is based in part on excerpts from copyrighted EJCDC documents. All rights reserved. Those portions of the text that originated in copyrighted EJCDC documents remain subject to the copyright.

required to provide monthly reports demonstrating good faith efforts to meet the work force goals using LCPTracker software.

- 22.04 A Bidder's failure to submit required information within the times indicated may disqualify Bidder from receiving an award of the Contract.

---

**00 21 13, Instructions to Bidders**

This document is a MODIFIED version of EJCDC® C-200, Copyright© 2018 by the National Society of Professional Engineers, American Council of Engineering Companies, and American Society of Civil Engineers, or is based in part on excerpts from copyrighted EJCDC documents. All rights reserved. Those portions of the text that originated in copyrighted EJCDC documents remain subject to the copyright.



## BID FORM

The terms used in this Bid with initial capital letters have the meanings stated in the Instructions to Bidders, the General Conditions, and the Supplementary Conditions.

### ARTICLE 1—OWNER AND BIDDER

- 1.01 This Bid is submitted to: Erie County Division of Purchase
- 1.02 The undersigned Bidder proposes and agrees, if this Bid is accepted, to enter into an Agreement with Owner in the form included in the Bidding Documents to perform all Work as specified or indicated in the Bidding Documents for the prices and within the times indicated in this Bid and in accordance with the other terms and conditions of the Bidding Documents.

### ARTICLE 2—ATTACHMENTS TO THIS BID

- 2.01 The following documents are submitted with and made a condition of this Bid:
  - A. Required Bid security;
  - B. New York State Vendor Responsibility Questionnaire Form CCA-2 with supporting attachments (from Section 00 73 75);
  - C. Invitation to Bid – Exhibit “G” Non-Collusive Bidding Certification
  - D. Exhibit BF-2 - Waiver of Immunity Certification;
  - E. Exhibit BF-3 – Confined Space and OSHA 10 Compliance Certifications;
  - F. Invitation to Bid – - Certification for Contracts, Grants, Loans, And Cooperative Agreements 40 CFR 34;
  - G. Equal Pay Certification (from Section 00 73 36);
  - H. New York State Certified Apprenticeship Training Program Certification (from Section 00 73 38);
  - I. Prime Contractor Affidavit (from Section 00 73 39);
  - J. Invitation to Bid – Exhibit “H” MBE/WBE Commitment ;
  - K. Erie County Executive Order #18 Attestation and Statement of Workforce (from Section 00 73 40);
  - L. Acknowledgement of Wage Schedule Receipt (from Section 00 73 43); and

### ARTICLE 3—BASIS OF BID—LUMP SUM BID AND UNIT PRICES

- 3.01 *Lump Sum Bids*
  - A. Bidder will complete the Work in accordance with the Contract Documents for the following lump sum (stipulated) price(s), together with any Unit Prices indicated in Paragraph 3.02:

---

#### 00 41 13, Bid Form

This document is a MODIFIED version of EJCDC® C-41, Copyright© 2018 by the National Society of Professional Engineers, American Council of Engineering Companies, and American Society of Civil Engineers, or is based in part on excerpts from copyrighted EJCDC documents. All rights reserved. Those portions of the text that originated in copyrighted EJCDC documents remain subject to the copyright.

B. The following contingency allowance is included in the price set forth below.

Bid Item No. 32 - Lump Sum Contingency Total	\$5,000.00
--	------------

C. Total of Lump Sum Bid Items

Total of all Lump Sum Bid Items	\$5,000.00
---------------------------------	------------

3.02 Unit Price Bids

A. The Unit Price Bid Items are divided into the following categories:

1. Part 1 - Contractor Bid Prices – Bid Items No. 1-6
2. Part 2 - Minimum Bid Prices – Bid Items No. 7-28, &
3. Part 3 - Fixed Bid Prices - Bid Items No. 29-31

B. Bidder will perform the following Work at the indicated unit prices:

PART 1 – CONTRACTOR BID PRICES					
Item No.	Description	Unit	Quantity	Bid Unit Price	Bid Amount
1A	8-12" Dia. Sewer Pipe Install ≥ 12 LF & < 100 LF (<8' depth)	LF	400	500 <sup>00</sup>	200,000 <sup>00</sup>
1B	8-12" Dia. Sewer Pipe Install ≥ 12 LF & < 100 LF (8.01'-12' depth)	LF	2,000	550 <sup>00</sup>	1,100,000 <sup>00</sup>
1C	8-12" Dia. Sewer Pipe Install ≥ 12 LF & < 100 LF (12'-16.01' depth)	LF	400	750 <sup>00</sup>	300,000 <sup>00</sup>
1D	8-12" Dia. Sewer Pipe Install ≥ 12 LF & < 100 LF (16.01'-20' depth)	LF	50	900 <sup>00</sup>	45,000 <sup>00</sup>
1E	>12-24" Dia. Sewer Pipe Install ≥ 12 LF & < 100 LF (<8' depth)	LF	50	700 <sup>00</sup>	35,000 <sup>00</sup>
1F	>12-24" Dia. Sewer Pipe Install ≥ 12 LF & < 100 LF (8.01'-12' depth)	LF	75	700 <sup>00</sup>	52,500 <sup>00</sup>
1G	>12-24" Dia. Sewer Pipe Install ≥ 12 LF & < 100 LF (12.01'-16' depth)	LF	50	800 <sup>00</sup>	40,000 <sup>00</sup>
1H	>12-24" Dia. Sewer Pipe Install ≥ 12 LF & < 100 LF (16.01'-20' depth)	LF	12	1500 <sup>00</sup>	18,000 <sup>00</sup>
1I	>24-42" Dia. Sewer Pipe Install ≥ 12 LF & < 100 LF (<8' depth)	LF	12	1,400 <sup>00</sup>	16,800 <sup>00</sup>
1J	>24-42" Dia. Sewer Pipe Install ≥ 12 LF & < 100 LF (8.01'-12' depth)	LF	20	2,000 <sup>00</sup>	40,000 <sup>00</sup>
1K	>24-42" Dia. Sewer Pipe Install ≥ 12 LF & < 100 LF (12.01'-16' depth)	LF	12	3,000 <sup>00</sup>	36,000 <sup>00</sup>
1L	>24-42" Dia. Sewer Pipe Install ≥ 12 LF & < 100 LF (16.01'-20' depth)	LF	12	3,500 <sup>00</sup>	42,000 <sup>00</sup>
1M	8-12" Dia. Sewer Pipe Install ≥ 100 LF (<8' depth)	LF	2,000	250 <sup>00</sup>	500,000 <sup>00</sup>
1N	8-12" Dia. Sewer Pipe Install ≥ 100 LF (8.01'-12' depth)	LF	400	275 <sup>00</sup>	110,000 <sup>00</sup>

00 41 13, Bid Form

This document is a MODIFIED version of EJCDC® C-41, Copyright© 2018 by the National Society of Professional Engineers, American Council of Engineering Companies, and American Society of Civil Engineers, or is based in part on excerpts from copyrighted EJCDC documents. All rights reserved. Those portions of the text that originated in copyrighted EJCDC documents remain subject to the copyright.

Item No.	Description	Unit	Quantity	Bid Unit Price	Bid Amount
1O	8-12" Dia. Sewer Pipe Install ≥ 100 LF (12.01'-16' depth)	LF	100	300 <sup>00</sup>	30,000 <sup>00</sup>
1P	8-12" Dia. Sewer Pipe Install ≥ 100 LF (16.01'-20' depth)	LF	100	325 <sup>00</sup>	32,500 <sup>00</sup>
1Q	>12-24" Dia. Sewer Pipe Install ≥ 100 LF (<8' depth)	LF	200	300 <sup>00</sup>	60,000 <sup>00</sup>
1R	>12-24" Dia. Sewer Pipe Install ≥ 100 LF (8.01'-12' depth)	LF	200	325 <sup>00</sup>	65,000 <sup>00</sup>
1S	>12-24" Dia. Sewer Pipe Install ≥ 100 LF (12.01'-16' depth)	LF	100	375 <sup>00</sup>	37,500 <sup>00</sup>
1T	>12-24" Dia. Sewer Pipe Install ≥ 100 LF (16.01'-20' depth)	LF	100	450 <sup>00</sup>	45,000 <sup>00</sup>
1U	>24-42" Dia. Sewer Pipe Install ≥ 100 LF (<8' depth)	LF	100	1,000 <sup>00</sup>	100,000 <sup>00</sup>
1V	>24-42" Dia. Sewer Pipe Install ≥ 100 LF (8.01'-12' depth)	LF	100	1,175 <sup>00</sup>	117,500 <sup>00</sup>
1W	>24-42" Dia. Sewer Pipe Install ≥ 100 LF (12.01'-16' depth)	LF	100	1,200 <sup>00</sup>	120,000 <sup>00</sup>
1X	>24-42" Dia. Sewer Pipe Install ≥ 100 LF (16.01'-20' depth)	LF	100	1,375 <sup>00</sup>	137,500 <sup>00</sup>
2A	6-8" Dia. Forcemain Install ≥ 12 LF & < 100 LF	LF	12	700 <sup>00</sup>	8,400 <sup>00</sup>
2B	>8-10" Dia. Forcemain Install ≥ 12 LF & < 100 LF	LF	12	725 <sup>00</sup>	8,700 <sup>00</sup>
2C	>10-12" Dia. Forcemain Install ≥ 12 LF & < 100 LF	LF	12	725 <sup>00</sup>	8,700 <sup>00</sup>
2D	>12-14" Dia. Forcemain Install ≥ 12 LF & < 100 LF	LF	12	750 <sup>00</sup>	9,000 <sup>00</sup>
2E	>14-16" Dia. Forcemain Install ≥ 12 LF & < 100 LF	LF	12	925 <sup>00</sup>	11,100 <sup>00</sup>
2F	>16-18" Dia. Forcemain Install ≥ 12 LF & < 100 LF	LF	12	925 <sup>00</sup>	11,100 <sup>00</sup>
2G	>18-21" Dia. Forcemain Install ≥ 12 LF & < 100 LF	LF	12	975 <sup>00</sup>	11,700 <sup>00</sup>
2H	>21-24" Dia. Forcemain Install ≥ 12 LF & < 100 LF	LF	12	1,075 <sup>00</sup>	12,900 <sup>00</sup>
2I	>24-36" Dia. Forcemain Install ≥ 12 LF & < 100 LF	LF	50	1,200 <sup>00</sup>	60,000 <sup>00</sup>
3A	4" Diameter Sewer Lateral Pipe Replacement (Any Depth)	LF	200	175 <sup>00</sup>	35,000 <sup>00</sup>
3B	6" Diameter Sewer Lateral Pipe Replacement (Any Depth)	LF	300	175 <sup>00</sup>	52,500 <sup>00</sup>
3C	6" Sewer Cleanout (Any Depth)	EA	50	500 <sup>00</sup>	25,000 <sup>00</sup>
3D	8" Sewer Cleanout, End of Line (Any Depth)	EA	25	750 <sup>00</sup>	18,750 <sup>00</sup>
3E	6" Sewer Cleanout Valve Box Cover	EA	5	240 <sup>00</sup>	1,200 <sup>00</sup>
3F	8" Sewer Cleanout Valve Box Cover	EA	5	320 <sup>00</sup>	1,600 <sup>00</sup>

00 41 13, Bid Form

This document is a MODIFIED version of EJCDC® C-41, Copyright© 2018 by the National Society of Professional Engineers, American Council of Engineering Companies, and American Society of Civil Engineers, or is based in part on excerpts from copyrighted EJCDC documents. All rights reserved. Those portions of the text that originated in copyrighted EJCDC documents remain subject to the copyright.

Item No.	Description	Unit	Quantity	Bid Unit Price	Bid Amount
4A	Connecting Lateral to Sewer (Wye Fitting)	EA	100	1,500 <sup>00</sup>	150,000 <sup>00</sup>
4B	Connecting Sewer to Sewer (Flexible Repair Coupling)	EA	100	1,200 <sup>00</sup>	120,000 <sup>00</sup>
4C	Force Main Sewer Connections	EA	6	1,500 <sup>00</sup>	9,000 <sup>00</sup>
4D	Connecting Sewer to Manhole	EA	25	1,200 <sup>00</sup>	30,000 <sup>00</sup>
4E	Manhole Coring (8" - 12" Sewer)	EA	10	750 <sup>00</sup>	7,500 <sup>00</sup>
4F	Manhole Coring (>12" - 24" Sewer)	EA	1	1,500 <sup>00</sup>	1,500 <sup>00</sup>
4G	Manhole Coring (>24" - 42" Sewer)	EA	1	1,500 <sup>00</sup>	1,500 <sup>00</sup>
4H	Connecting Storm Sewer to Catch Basin	EA	1	1,250 <sup>00</sup>	1,250 <sup>00</sup>
4I	Connecting Lateral to Sewer (Tap Saddle Fitting)	EA	2	1,500 <sup>00</sup>	3,000 <sup>00</sup>
5A	4' Diameter Standard Manhole	VLF	100	1,400 <sup>00</sup>	140,000 <sup>00</sup>
5B	5' Diameter Standard Manhole	VLF	10	2,000 <sup>00</sup>	20,000 <sup>00</sup>
5C	6' Diameter Standard Manhole	VLF	10	2,200 <sup>00</sup>	22,000 <sup>00</sup>
5D	8' Diameter Standard Manhole	VLF	10	4,500 <sup>00</sup>	45,000 <sup>00</sup>
5E	4' Diameter Doghouse Manhole	VLF	20	2,000 <sup>00</sup>	40,000 <sup>00</sup>
5F	5' Diameter Doghouse Manhole	VLF	10	2,500 <sup>00</sup>	25,000 <sup>00</sup>
5G	6' Diameter Doghouse Manhole	VLF	10	2,750 <sup>00</sup>	27,500 <sup>00</sup>
5H	8' Diameter Doghouse Manhole	VLF	10	5,200 <sup>00</sup>	52,000 <sup>00</sup>
5I	Precast Concrete Catch Basin	VLF	10	1,500 <sup>00</sup>	15,000 <sup>00</sup>
6A	Heavy Duty Pavement Restoration (Less than 50 SF)	SF	100	45 <sup>00</sup>	4,500 <sup>00</sup>
6B	Heavy Duty Pavement Restoration (50-249.9 SF)	SF	1000	25 <sup>00</sup>	25,000 <sup>00</sup>
6C	Heavy Duty Pavement Restoration (250-499.9 SF)	SF	1500	23 <sup>00</sup>	34,500 <sup>00</sup>
6D	Heavy Duty Pavement Restoration (500 SF and greater)	SF	2000	20 <sup>00</sup>	40,000 <sup>00</sup>
6E	Medium Duty Pavement Restoration (Less than 50 SF)	SF	100	40 <sup>00</sup>	4,000 <sup>00</sup>
6F	Medium Duty Pavement Restoration (50-249.9 SF)	SF	1000	27 <sup>00</sup>	27,000 <sup>00</sup>
6G	Medium Duty Pavement Restoration (250-499.9 SF)	SF	1500	25 <sup>00</sup>	37,500 <sup>00</sup>
6H	Medium Duty Pavement Restoration (500 SF and greater)	SF	2000	20 <sup>00</sup>	40,000 <sup>00</sup>

00 41 13, Bid Form

This document is a MODIFIED version of EJCDC® C-41, Copyright© 2018 by the National Society of Professional Engineers, American Council of Engineering Companies, and American Society of Civil Engineers, or is based in part on excerpts from copyrighted EJCDC documents. All rights reserved. Those portions of the text that originated in copyrighted EJCDC documents remain subject to the copyright.



Item No.	Description	Unit	Quantity	Bid Unit Price	Bid Amount
6I	Light Duty Pavement Restoration (Less than 50 SF)	SF	100	45 <sup>00</sup>	4,500 <sup>00</sup>
6J	Light Duty Pavement Restoration (50-249.9 SF)	SF	1000	45 <sup>00</sup>	45,000 <sup>00</sup>
6K	Light Duty Pavement Restoration (250-499.9 SF)	SF	1500	24 <sup>00</sup>	36,000 <sup>00</sup>
6L	Light Duty Pavement Restoration (500 SF and greater)	SF	2000	22 <sup>00</sup>	44,000 <sup>00</sup>
6M	Concrete Roadbase Pavement Restoration (Less than 50 SF)	SF	100	50 <sup>00</sup>	5,000 <sup>00</sup>
6N	Concrete Roadbase Pavement Restoration (50-249.9 SF)	SF	1000	32 <sup>00</sup>	32,000 <sup>00</sup>
6O	Concrete Roadbase Pavement Restoration (250-499.9 SF)	SF	1500	32 <sup>00</sup>	48,000 <sup>00</sup>
6P	Concrete Roadbase Pavement Restoration (500 SF and greater)	SF	2000	32 <sup>00</sup>	64,000 <sup>00</sup>
<b>PART 1 TOTAL</b>					\$ 4,157,200 <sup>00</sup>

PART 2 – MINIMUM BID PRICES						
Item No.	Description	Unit	Quantity	Minimum Unit Price	Bid Unit Price	Bid Amount
7A	Miscellaneous Cold Milling of Asphalt Concrete (Less than 3,000 SF)	SF	1000	\$10.00	16 <sup>00</sup>	16,000 <sup>00</sup>
7B	Miscellaneous Cold Milling of Asphalt Concrete (Greater than 3,000 SF)	SF	3000	\$10.00	16 <sup>00</sup>	48,000 <sup>00</sup>
7C	1-1/2" Top Course Asphalt Concrete Pavement Restoration in areas of cold milling only	SF	1000	\$3.00	20 <sup>00</sup>	20,000 <sup>00</sup>
7D	Temporary Pavement Patch (Asphalt)	SF	500	\$4.00	8 <sup>00</sup>	4,000 <sup>00</sup>
7E	Temporary Pavement Patch (Concrete)	SF	500	\$15.00	15 <sup>00</sup>	7,500 <sup>00</sup>
7F	Shoulder Replacement	SF	500	\$15.00	25 <sup>00</sup>	12,500 <sup>00</sup>
7G	Additional Sawcut (Pavement)	LF	10	\$5.00	25 <sup>00</sup>	250 <sup>00</sup>
7H	Pavement Stripe	LF	200	\$12.00	25 <sup>00</sup>	300 <sup>00</sup>
7I	Pavement Letter	EA	10	\$100.00	300 <sup>00</sup>	3,000 <sup>00</sup>
7J	Pavement Symbol	EA	5	\$100.00	300 <sup>00</sup>	1,500 <sup>00</sup>

**00 41 13, Bid Form**

This document is a MODIFIED version of EJCDC® C-41, Copyright© 2018 by the National Society of Professional Engineers, American Council of Engineering Companies, and American Society of Civil Engineers, or is based in part on excerpts from copyrighted EJCDC documents. All rights reserved. Those portions of the text that originated in copyrighted EJCDC documents remain subject to the copyright.

Item No.	Description	Unit	Quantity	Minimum Unit Price	Bid Unit Price	Bid Amount
8A	Drop Manhole Pipe Assemblies (6"-8" Sewer)	EA	5	\$500.00	2,000 <sup>00</sup>	10,000 <sup>00</sup>
8B	Drop Manhole Pipe Assemblies (10"-12" Sewer)	EA	5	\$500.00	2,500 <sup>00</sup>	12,500 <sup>00</sup>
8C	Drop Manhole Pipe Assemblies (15"-18" Sewer)	EA	1	\$750.00	4,000 <sup>00</sup>	4,000 <sup>00</sup>
8D	Drop Manhole Pipe Assemblies (21"-24" Sewer)	EA	1	\$1,000.00	4,500 <sup>00</sup>	4,500 <sup>00</sup>
9	Concrete Cradle and Encasement	CY	5	\$80.00	500 <sup>00</sup>	2,500 <sup>00</sup>
10	Additional Crushed Stone Bedding	CY	50	\$30.00	58 <sup>00</sup>	2,900 <sup>00</sup>
11	Select Material Backfill	CY	2500	\$10.00	40 <sup>00</sup>	100,000 <sup>00</sup>
12	Additional Stone for Undercut	CY	50	\$10.00	50 <sup>00</sup>	2,500 <sup>00</sup>
13	Unclassified Excavation and Disposal	CY	50	\$5.00	25 <sup>00</sup>	1,250 <sup>00</sup>
14	Rock Excavation	CY	120	\$50.00	250 <sup>00</sup>	30,000 <sup>00</sup>
15	Test Pit Excavation (up to 4 CY)	EA	10	\$400.00	750 <sup>00</sup>	7,500 <sup>00</sup>
16A	Abandon Existing Sewer - Bulkhead/Plug	EA	10	\$100.00	250 <sup>00</sup>	2,500 <sup>00</sup>
16B	Abandon Existing Sewer - Filling of Voids	CY	10	\$150.00	400 <sup>00</sup>	4,000 <sup>00</sup>
16C	Abandon Existing Sewer - Manholes (In Pavement)	EA	10	\$500.00	1,500 <sup>00</sup>	15,000 <sup>00</sup>
16D	Abandon Existing Sewer - Manholes (In Lawn)	EA	5	\$400.00	1,500 <sup>00</sup>	7,500 <sup>00</sup>
16E	Abandon Existing Sewer - Cleanout	EA	10	\$200.00	1,500 <sup>00</sup>	5,000 <sup>00</sup>
17A	Concrete Sidewalk Restoration	SF	1000	\$12.00	18 <sup>00</sup>	18,000 <sup>00</sup>
17B	Concrete Driveway Restoration	SF	1000	\$12.00	21 <sup>00</sup>	21,000 <sup>00</sup>
17C	Asphalt Driveway Restoration - Light Duty (≤ 4.5" thick total)	SF	100	\$15.00	45 <sup>00</sup>	4,500 <sup>00</sup>
17D	Asphalt Driveway Restoration - Medium Duty (> 4.5" thick total)	SF	500	\$15.00	45 <sup>00</sup>	22,500 <sup>00</sup>
17E	Reset Existing Brick Pavers/Stone Sidewalk	SF	100	\$15.00	30 <sup>00</sup>	3,000 <sup>00</sup>
17F	ADA Ramp Detectable Warning Units, Embedded	SF	10	\$25.00	35 <sup>00</sup>	3,500 <sup>00</sup>
18A	Concrete Gutter Restoration	LF	50	\$15.00	90 <sup>00</sup>	4,500 <sup>00</sup>
18B	Concrete Curbing Restoration	LF	100	\$15.00	90 <sup>00</sup>	9,000 <sup>00</sup>
18C	New Stone Curbing Restoration	LF	25	\$15.00	90 <sup>00</sup>	2,250 <sup>00</sup>

00 41 13, Bid Form

This document is a MODIFIED version of EJCDC® C-41, Copyright© 2018 by the National Society of Professional Engineers, American Council of Engineering Companies, and American Society of Civil Engineers, or is based in part on excerpts from copyrighted EJCDC documents. All rights reserved. Those portions of the text that originated in copyrighted EJCDC documents remain subject to the copyright.

Item No.	Description	Unit	Quantity	Minimum Unit Price	Bid Unit Price	Bid Amount
18D	Reset Existing Stone Curbing	LF	50	\$10.00	55 <sup>00</sup>	1,375 <sup>00</sup>
18E	Curb Ramp, NYSDOT Type 1	EA	1	\$1,500.00	3,500 <sup>00</sup>	3,500 <sup>00</sup>
18F	Curb Ramp, NYSDOT Type 4	EA	1	\$1,500.00	4,500 <sup>00</sup>	4,500 <sup>00</sup>
18G	Curb Ramp, NYSDOT Type 8	EA	1	\$1,500.00	4,500 <sup>00</sup>	4,500 <sup>00</sup>
18H	Curb Ramp, NYSDOT Type 9	EA	1	\$1,500.00	3,500 <sup>00</sup>	3,500 <sup>00</sup>
19A	Clear and Grub (> 0 to 30 SY per mobilization)	SY	30	\$10.00	50 <sup>00</sup>	1,500 <sup>00</sup>
19B	Clear and Grub (> 30 SY to 100 SY per mobilization)	SY	100	\$10.00	50 <sup>00</sup>	5,000 <sup>00</sup>
19C	Clear and Grub - Remove shrubs or hedges (< 4 feet tall)	LF	10	\$20.00	20 <sup>00</sup>	200 <sup>00</sup>
19D	Clear and Grub - Remove shrubs or hedges (> 4.01 feet to 8 feet tall)	LF	10	\$20.00	25 <sup>00</sup>	250 <sup>00</sup>
19E	Tree Removal (Under 8-inch diameter)	EA	3	\$100.00	250 <sup>00</sup>	750 <sup>00</sup>
19F	Tree Removal (>8-inch to 15-inch diameter)	EA	1	\$300.00	750 <sup>00</sup>	750 <sup>00</sup>
19G	Tree Removal (>15-inch to 24-inch diameter)	EA	1	\$425.00	1,500 <sup>00</sup>	1,500 <sup>00</sup>
19H	Tree Removal (>24-inch diameter)	EA	1	\$600.00	2,000 <sup>00</sup>	2,000 <sup>00</sup>
19I	Tree Stump Removal and Re-grade	EA	1	\$500.00	500 <sup>00</sup>	500 <sup>00</sup>
20	Lawn Restoration - Topsoil and Seed	SF	9000	\$1.00	3 <sup>00</sup>	27,000 <sup>00</sup>
21A	Tree Replacement (2- or 3-inch diameter trees 6' to 8' high)	EA	1	\$200.00	500 <sup>00</sup>	500 <sup>00</sup>
21B	Shrub/Hedge Replacement (3-foot tall)	EA	3	\$150.00	250 <sup>00</sup>	750 <sup>00</sup>
22A	Manhole Frame Adjustment	EA	25	\$450.00	1,800 <sup>00</sup>	45,000 <sup>00</sup>
22B	Catch Basin Frame Adjustment	EA	1	\$250.00	1,500 <sup>00</sup>	1,500 <sup>00</sup>
23A	Install 4" to 6" Storm Underdrain	LF	25	\$10.00	50 <sup>00</sup>	1,250 <sup>00</sup>
23B	Install 8" to 12" Storm Underdrain	LF	25	\$15.00	75 <sup>00</sup>	1,875 <sup>00</sup>
24A	Support of Utilities Crossing Excavation Trench - 4" to <8" Diameter Utility	EA	10	\$100.00	500 <sup>00</sup>	5,000 <sup>00</sup>
24B	Support of Utilities Crossing Excavation Trench - 8" or > Diameter Utility	EA	10	\$200.00	600 <sup>00</sup>	6,000 <sup>00</sup>
24C	Temporary Tight Sheeting for Utility Support	SF	100	\$5.00	250 <sup>00</sup>	25,000 <sup>00</sup>
24D	Temporary Support of Utility Poles During Excavation Work	EA	2	\$500.00	500 <sup>00</sup>	1,000 <sup>00</sup>

00 41 13, Bid Form

This document is a MODIFIED version of EJCDC® C-41, Copyright© 2018 by the National Society of Professional Engineers, American Council of Engineering Companies, and American Society of Civil Engineers, or is based in part on excerpts from copyrighted EJCDC documents. All rights reserved. Those portions of the text that originated in copyrighted EJCDC documents remain subject to the copyright.



Item No.	Description	Unit	Quantity	Minimum Unit Price	Bid Unit Price	Bid Amount
25A	CCTV Inspection (8" to 12")	LF	100	\$3.00	24 <sup>00</sup>	2,400 <sup>00</sup>
25B	CCTV Inspection (12" to 24")	LF	50	\$4.00	48 <sup>00</sup>	2,400 <sup>00</sup>
25C	See Snake Inspection	HR	5	\$50.00	200 <sup>00</sup>	1,000 <sup>00</sup>
26A	Traffic Control – Flagperson (Per Hour)	HR	8	\$60.00	100 <sup>00</sup>	800 <sup>00</sup>
26B	Traffic Control – Flagperson (Per Week)	WEEK	1	\$2,500.00	4,000 <sup>00</sup>	4,000 <sup>00</sup>
27A	Portable Advance Warning Arrow Panel (Rental Per Day)	DAY	10	\$100.00	100 <sup>00</sup>	1,000 <sup>00</sup>
27B	Portable Advance Warning Arrow Panel (Rental Per Week)	WEEK	2	\$300.00	300 <sup>00</sup>	600 <sup>00</sup>
27C	Portable Traffic Signals (Rental Per Day)	DAY	10	\$450.00	550 <sup>00</sup>	5,500 <sup>00</sup>
27D	Portable Traffic Signals (Rental Per Week)	WEEK	2	\$1,500.00	2,750 <sup>00</sup>	5,500 <sup>00</sup>
27E	Attenuator Truck (Rental Per Day)	DAY	10	\$100.00	250 <sup>00</sup>	2,500 <sup>00</sup>
27F	Attenuator Truck (Rental Per Week)	WEEK	2	\$300.00	600 <sup>00</sup>	600 <sup>00</sup>
27G	Type III Barricade (Rental Per Day)	DAY	10	\$25.00	25 <sup>00</sup>	250 <sup>00</sup>
27H	Type III Barricade (Rental Per Week)	WEEK	2	\$100.00	100 <sup>00</sup>	200 <sup>00</sup>
27I	Traffic Control Device Delivery/Set Up/Removal	EA	20	\$200.00	200 <sup>00</sup>	4,000 <sup>00</sup>
27J	Traffic Control Work Plan Development	EA	10	\$250.00	250 <sup>00</sup>	2,500 <sup>00</sup>
28A	Asbestos Abatement, Handling, and Disposal (Hourly)	HR	16	\$375.00	375 <sup>00</sup>	6,000 <sup>00</sup>
28B	Asbestos Abatement, Handling, and Disposal (Daily)	DAY	2	\$3,000.00	3,000 <sup>00</sup>	6,000 <sup>00</sup>
	<b>PART 2 TOTAL</b>			\$227,205.00 minimum		598,150 <sup>00</sup>

00 41 13, Bid Form

This document is a MODIFIED version of EJCDC® C-41, Copyright© 2018 by the National Society of Professional Engineers, American Council of Engineering Companies, and American Society of Civil Engineers, or is based in part on excerpts from copyrighted EJCDC documents. All rights reserved. Those portions of the text that originated in copyrighted EJCDC documents remain subject to the copyright.

PART 3 – FIXED BID PRICES					
Item No.	Description	Unit	Quantity	Fixed Bid Unit Price	Bid Amount
29	Downtime (Directed by Owner) – Fixed Price	HR	1	\$500.00	\$500.00
30A	Mobilization to Project Site (Once per Work Order) - Fixed Price	EA	1	\$1,500.00	\$1,500.00
30B	Mobilization (as Directed by Owner) (between Erie County sites) - Fixed Price	HR	1	\$250.00	\$250.00
31	Consulting/Site Visits/Meetings - Fixed Price	HR	5	\$150.00	\$750.00
	<b>PART 3 TOTAL</b>	-	-	-	\$3,000.00

Unit Price Bid Item Sub-Total By Part	Unit Price Bid Amount
Part 1 Total	\$ 4,757,200 <sup>00</sup>
Part 2 Total	\$ 598,150 <sup>00</sup>
Part 3 Total (Fixed)	\$3,000.00
Total of All Unit Price Bid Items (Part 1 + Part 2 + Part 3)	\$ 5,358,350 <sup>00</sup>

C. Bidder acknowledges that:

- each Bid Unit Price includes an amount considered by Bidder to be adequate to cover Contractor's overhead and profit for each separately identified item, and
- quantities provided in the Bid Form section are provided for the purpose of determining a low bidder only. Actual quantities assigned and work will be conducted on a Work Order basis over the term of this Contract. The quantities provided are not guaranteed.

3.03 Total Bid Price (Lump Sum and Unit Prices)

Total Bid Price (Total of all Lump Sum and Unit Price Bids)	\$ 5,358,350 <sup>00</sup>
---	----------------------------

00 41 13, Bid Form

This document is a MODIFIED version of EJCDC® C-41, Copyright© 2018 by the National Society of Professional Engineers, American Council of Engineering Companies, and American Society of Civil Engineers, or is based in part on excerpts from copyrighted EJCDC documents. All rights reserved. Those portions of the text that originated in copyrighted EJCDC documents remain subject to the copyright.

**ARTICLE 4—BASIS OF BID—COST-PLUS FEE – NOT USED**

**ARTICLE 5—PRICE-PLUS-TIME BID - NOT USED**

**ARTICLE 6—TIME OF COMPLETION**

- 6.01 Bidder agrees that the Work will be substantially complete and will be completed and ready for final payment in accordance with Paragraph 15.06 of the General Conditions on or before the dates or within the number of days indicated in the Agreement.
- 6.02 Bidder accepts the provisions of the Agreement as to liquidated and special damages.
- 6.03 Work Orders shall be substantially completed within the timeframe stated in each Work Order issuance letter. If the completion date of a Work Order extends beyond the time of this Contract, the terms of this Contract shall be extended to the completion of the Work Order

**ARTICLE 7—BIDDER’S ACKNOWLEDGEMENTS: ACCEPTANCE PERIOD, INSTRUCTIONS, AND RECEIPT OF ADDENDA.**

- 7.01 *Bid Acceptance Period*
  - A. This Bid will remain subject to acceptance for 45 days after the Bid opening, or for such longer period of time that Bidder may agree to in writing upon request of Owner.
- 7.02 *Instructions to Bidders*
  - A. Bidder accepts all of the terms and conditions of the Instructions to Bidders, including without limitation those dealing with the disposition of Bid security.
- 7.03 *Receipt of Addenda*
  - A. Bidder hereby acknowledges receipt of the following Addenda:

Addendum Number	Addendum Date
1	12/21/23
2	12/21/23
3	1/8/24

**ARTICLE 8—BIDDER’S REPRESENTATIONS AND CERTIFICATIONS**

- 8.01 *Bidder’s Representations*
  - A. In submitting this Bid, Bidder represents the following:
    - 1. Bidder has examined and carefully studied the Bidding Documents, including Addenda.
    - 2. Bidder is familiar with all Laws and Regulations that may affect cost, progress, and performance of the Work.
    - 3. Bidder has considered the information known to Bidder itself; information commonly known to contractors doing business in the locality of the Site; the Bidding Documents; (b) the means, methods, techniques, sequences, and procedures of construction to be

employed by Bidder, if selected as Contractor; and (c) Bidder's (Contractor's) safety precautions and programs.

4. Bidder is aware of the general nature of work to be performed by Owner and others at the Site that relates to the Work as indicated in the Bidding Documents.
5. Bidder has given Engineer written notice of all conflicts, errors, ambiguities, or discrepancies that Bidder has discovered in the Bidding Documents, and of discrepancies between Site conditions and the Contract Documents, and the written resolution thereof by Engineer is acceptable to Contractor.
6. The Bidding Documents are generally sufficient to indicate and convey understanding of all terms and conditions for performance and furnishing of the Work.
7. The submission of this Bid constitutes an incontrovertible representation by Bidder that without exception the Bid and all prices in the Bid are premised upon performing and furnishing the Work required by the Bidding Documents.
8. Bidder is aware that Successful Bidder will need to comply with Erie County Executive Order 13 (2014). See Section 00 73 36.
9. Bidder is aware that Successful Bidder will need to comply with Erie County Executive Order 18 (2017). See Section 00 73 40.

#### 8.02 *Bidder's Certifications*

A. The Bidder certifies the following:

1. This Bid is genuine and not made in the interest of or on behalf of any undisclosed individual or entity and is not submitted in conformity with any collusive agreement or rules of any group, association, organization, or corporation.
2. Bidder has not directly or indirectly induced or solicited any other Bidder to submit a false or sham Bid.
3. Bidder has not solicited or induced any individual or entity to refrain from bidding.
4. Bidder has not engaged in corrupt, fraudulent, collusive, or coercive practices in competing for the Contract. For the purposes of this Paragraph 8.02.A:
  - a. Corrupt practice means the offering, giving, receiving, or soliciting of anything of value likely to influence the action of a public official in the bidding process.
  - b. Fraudulent practice means an intentional misrepresentation of facts made (a) to influence the bidding process to the detriment of Owner, (b) to establish bid prices at artificial non-competitive levels, or (c) to deprive Owner of the benefits of free and open competition.
  - c. Collusive practice means a scheme or arrangement between two or more Bidders, with or without the knowledge of Owner, a purpose of which is to establish bid prices at artificial, non-competitive levels.

---

#### 00 41 13, Bid Form

This document is a MODIFIED version of EJCDC® C-41, Copyright© 2018 by the National Society of Professional Engineers, American Council of Engineering Companies, and American Society of Civil Engineers, or is based in part on excerpts from copyrighted EJCDC documents. All rights reserved. Those portions of the text that originated in copyrighted EJCDC documents remain subject to the copyright.

- d. Coercive practice means harming or threatening to harm, directly or indirectly, persons or their property to influence their participation in the bidding process or affect the execution of the Contract.

---

**00 41 13, Bid Form**

This document is a MODIFIED version of EJCDC® C-41, Copyright© 2018 by the National Society of Professional Engineers, American Council of Engineering Companies, and American Society of Civil Engineers, or is based in part on excerpts from copyrighted EJCDC documents. All rights reserved. Those portions of the text that originated in copyrighted EJCDC documents remain subject to the copyright.



BIDDER hereby submits this Bid as set forth above:

Bidder:

Visone Construction Inc  
(typed or printed name of organization)

By:

*David Visone*  
(individual's signature)

Name:

David Visone  
(typed or printed)

Title:

President  
(typed or printed)

Date:

1/11/24  
(typed or printed)

If Bidder is a corporation, a partnership, or a joint venture, attach evidence of authority to sign.

Attest:

*Anthony F. Magka*  
(individual's signature)

Name:

Anthony F. Magka  
(typed or printed)

Title:

Ass't Estimator  
(typed or printed)

Date:

1/11/24  
(typed or printed)

Address for giving notices:

79 Sheldon Ave  
Deer, NY 14043

Bidder's Contact:

Name:

David Visone  
(typed or printed)

Title:

President  
(typed or printed)

Phone:

716-681-7331

Email:

estimating@visoneconstruction@gmail.com

Address:

79 Sheldon Ave  
Deer, NY 14043

Bidder's Contractor License No.: (if applicable)

00 41 13, Bid Form

This document is a MODIFIED version of EJCDC® C-41, Copyright© 2018 by the National Society of Professional Engineers, American Council of Engineering Companies, and American Society of Civil Engineers, or is based in part on excerpts from copyrighted EJCDC documents. All rights reserved. Those portions of the text that originated in copyrighted EJCDC documents remain subject to the copyright.

EXHIBIT BF-2 – WAIVER OF IMMUNITY CERTIFICATION

This is to CERTIFY that neither the undersigned nor any member, partner, director, or officer of the firm has refused to sign a waiver of immunity against subsequent criminal prosecution or to answer any relevant question concerning a transaction or contract with the state or any political subdivision thereof, a public authority or with a public department, agency or official of the state or of any political subdivision thereof or of a public authority, when called before a grand jury, head of a state department, temporary state commission, or other state agency, the organized crime task force in the department of law, head of a city department or other city agency, which is empowered to compel the attendance of witnesses and examine them under oath.

(CORPORATE SEAL)

(If bid is by a Corporation)

By: [Signature] Visone Construction, Inc.  
Contractor's Signature Business Name

Name: David Visone Date: 11/11/24  
Typed or Printed Name

Title: President

00 41 13, Bid Form

This document is a MODIFIED version of EJCDC® C-41, Copyright© 2018 by the National Society of Professional Engineers, American Council of Engineering Companies, and American Society of Civil Engineers, or is based in part on excerpts from copyrighted EJCDC documents. All rights reserved. Those portions of the text that originated in copyrighted EJCDC documents remain subject to the copyright.



EXHIBIT BF-3 – CONFINED SPACE AND OSHA 10 COMPLIANCE CERTIFICATIONS

CONFINED SPACE PROGRAM CERTIFICATION

This is to certify that Visone Construction, Inc has established a  
(Company Name)

Confined Space Program which conforms to OSHA 29 CFR Part 1910, as it may be amended. Furthermore, it is understood that full implementation of the contractor's Confined Space Program is a requirement of this contract.

OSHA 10 COMPLIANCE CERTIFICATION

(Chapter 282 of Law of 2007, codified as Labor Law 220-h)

Contractor certifies that every worker employed in the performance of this contract has completed the OSHA 10 Safety Training Course. The Contractor will submit a copy of Proof of Completion of the OSHA 10 Safety Training Course for all workers, Contractors and Subcontractors, with the first certified payroll submitted and on succeeding certified payrolls when any new employee is on the contract. Proof of Completion may include a copy of a bona fide course completion card; a training roster, attendance record, or other documentation from the certified trainer; and/or other valid proof. A certification by the Contractor attesting that all employees have completed such course is not sufficient proof that the course has been completed.

Furthermore, it is understood that completion of the OSHA 10 Safety Training Course by all workers, contractors and subcontractors employed in the performance of this Contract is a requirement of this contract.

By: [Signature] Visone Construction Inc  
Contractor's Signature Business Name

Name: David Visone Date: 1/11/24  
Typed or Printed Name

Title: President

# STANDARD GENERAL CONDITIONS OF THE CONSTRUCTION CONTRACT

## TABLE OF CONTENTS

	Page
Article 1—Definitions and Terminology.....	1
1.01 Defined Terms.....	1
1.02 Terminology.....	6
Article 2—Preliminary Matters.....	7
2.01 Delivery of Performance and Payment Bonds; Evidence of Insurance.....	7
2.02 Copies of Documents.....	7
2.03 Before Starting Construction.....	7
2.04 Preconstruction Conference; Designation of Authorized Representatives.....	8
2.05 Acceptance of Schedules.....	8
2.06 Electronic Transmittals.....	8
Article 3—Contract Documents: Intent, Requirements, Reuse.....	9
3.01 Intent.....	9
3.02 Reference Standards.....	9
3.03 Reporting and Resolving Discrepancies.....	10
3.04 Requirements of the Contract Documents.....	10
3.05 Reuse of Documents.....	11
Article 4—Commencement and Progress of the Work.....	11
4.01 Commencement of Contract Times; Notice to Proceed.....	11
4.02 Starting the Work.....	11
4.03 Reference Points.....	11
4.04 Progress Schedule.....	12
4.05 Delays in Contractor’s Progress.....	12
Article 5—Site; Subsurface and Physical Conditions; Hazardous Environmental Conditions.....	13
5.01 Availability of Lands.....	13
5.02 Use of Site and Other Areas.....	14
5.03 Subsurface and Physical Conditions.....	15

5.04	Differing Subsurface or Physical Conditions .....	16
5.05	Underground Facilities.....	17
5.06	Hazardous Environmental Conditions at Site .....	19
Article 6—Bonds and Insurance.....		21
6.01	Performance, Payment, and Other Bonds .....	21
6.02	Insurance—General Provisions .....	22
6.03	Contractor’s Insurance.....	24
6.04	Builder’s Risk and Other Property Insurance .....	25
6.05	Property Losses; Subrogation .....	25
6.06	Receipt and Application of Property Insurance Proceeds .....	27
Article 7—Contractor’s Responsibilities .....		27
7.01	Contractor’s Means and Methods of Construction .....	27
7.02	Supervision and Superintendence .....	27
7.03	Labor; Working Hours .....	27
7.04	Services, Materials, and Equipment .....	28
7.05	“Or Equals” .....	28
7.06	Substitutes .....	29
7.07	Concerning Subcontractors and Suppliers .....	31
7.08	Patent Fees and Royalties.....	32
7.09	Permits .....	33
7.10	Taxes .....	33
7.11	Laws and Regulations.....	33
7.12	Record Documents.....	33
7.13	Safety and Protection .....	34
7.14	Hazard Communication Programs .....	35
7.15	Emergencies.....	35
7.16	Submittals .....	35
7.17	Contractor’s General Warranty and Guarantee .....	38
7.18	Indemnification .....	39
7.19	Delegation of Professional Design Services .....	39
Article 8—Other Work at the Site.....		40
8.01	Other Work .....	40
8.02	Coordination .....	41

8.03	Legal Relationships.....	41
Article 9—Owner’s Responsibilities.....		42
9.01	Communications to Contractor .....	42
9.02	Replacement of Engineer.....	42
9.03	Furnish Data.....	42
9.04	Pay When Due.....	42
9.05	Lands and Easements; Reports, Tests, and Drawings.....	43
9.06	Insurance.....	43
9.07	Change Orders .....	43
9.08	Inspections, Tests, and Approvals.....	43
9.09	Limitations on Owner’s Responsibilities .....	43
9.10	Undisclosed Hazardous Environmental Condition.....	43
9.11	Evidence of Financial Arrangements.....	43
9.12	Safety Programs .....	43
Article 10—Engineer’s Status During Construction.....		44
10.01	Owner’s Representative.....	44
10.02	Visits to Site.....	44
10.03	Resident Project Representative.....	44
10.04	Engineer’s Authority .....	44
10.05	Determinations for Unit Price Work .....	45
10.06	Decisions on Requirements of Contract Documents and Acceptability of Work .....	45
10.07	Limitations on Engineer’s Authority and Responsibilities .....	45
10.08	Compliance with Safety Program.....	45
Article 11—Changes to the Contract .....		46
11.01	Amending and Supplementing the Contract .....	46
11.02	Change Orders .....	46
11.03	Work Change Directives.....	46
11.04	Field Orders.....	47
11.05	Owner-Authorized Changes in the Work.....	47
11.06	Unauthorized Changes in the Work.....	47
11.07	Change of Contract Price .....	47
11.08	Change of Contract Times .....	49
11.09	Change Proposals.....	49

11.10	Notification to Surety.....	50
Article 12—Claims.....		50
12.01	Claims.....	50
Article 13—Cost of the Work; Allowances; Unit Price Work .....		51
13.01	Cost of the Work .....	51
13.02	Allowances .....	55
13.03	Unit Price Work .....	55
Article 14—Tests and Inspections; Correction, Removal, or Acceptance of Defective Work .....		56
14.01	Access to Work.....	56
14.02	Tests, Inspections, and Approvals.....	56
14.03	Defective Work .....	57
14.04	Acceptance of Defective Work.....	58
14.05	Uncovering Work .....	58
14.06	Owner May Stop the Work .....	58
14.07	Owner May Correct Defective Work.....	59
Article 15—Payments to Contractor; Set-Offs; Completion; Correction Period .....		59
15.01	Progress Payments.....	59
15.02	Contractor’s Warranty of A.....	62
15.03	Substantial Completion.....	62
15.04	Partial Use or Occupancy .....	63
15.05	Final Inspection .....	64
15.06	Final Payment.....	64
15.07	Waiver of Claims .....	65
15.08	Correction Period.....	66
Article 16—Suspension of Work and Termination .....		67
16.01	Owner May Suspend Work .....	67
16.02	Owner May Terminate for Cause.....	67
16.03	Owner May Terminate for Convenience.....	68
16.04	Contractor May Stop Work or Terminate.....	68
Article 17—Final Resolution of Disputes .....		69
17.01	Methods and Procedures.....	69
Article 18—Miscellaneous .....		69
18.01	Giving Notice .....	69

18.02	Computation of Times.....	69
18.03	Cumulative Remedies .....	70
18.04	Limitation of Damages .....	70
18.05	No Waiver .....	70
18.06	Survival of Obligations .....	70
18.07	Controlling Law .....	70
18.08	Assignment of Contract.....	70
18.09	Successors and Assigns .....	70
18.10	Headings.....	70

# STANDARD GENERAL CONDITIONS OF THE CONSTRUCTION CONTRACT

## ARTICLE 1—DEFINITIONS AND TERMINOLOGY

### 1.01 *Defined Terms*

- A. Wherever used in the Bidding Requirements or Contract Documents, a term printed with initial capital letters, including the term's singular and plural forms, will have the meaning indicated in the definitions below. In addition to terms specifically defined, terms with initial capital letters in the Contract Documents include references to identified articles and paragraphs, and the titles of other documents or forms.
1. *Addenda*—Written or graphic instruments issued prior to the opening of Bids which clarify, correct, or change the Bidding Requirements or the proposed Contract Documents.
  2. *Agreement*—The written instrument, executed by Owner and Contractor, that sets forth the Contract Price and Contract Times, identifies the parties and the Engineer, and designates the specific items that are Contract Documents.
  3. *Application for Payment*—The document prepared by Contractor, in a form acceptable to Engineer, to request progress or final payments, and which is to be accompanied by such supporting documentation as is required by the Contract Documents.
  4. *Bid*—The offer of a Bidder submitted on the prescribed form setting forth the prices for the Work to be performed.
  5. *Bidder*—An individual or entity that submits a Bid to Owner.
  6. *Bidding Documents*—The Bidding Requirements, the proposed Contract Documents, and all Addenda.
  7. *Bidding Requirements*—The Advertisement or invitation to bid, Instructions to Bidders, Bid Bond or other Bid security, if any, the Bid Form, and the Bid with any attachments.
  8. *Change Order*—A document which is signed by Contractor and Owner and authorizes an addition, deletion, or revision in the Work or an adjustment in the Contract Price or the Contract Times, or other revision to the Contract, issued on or after the Effective Date of the Contract.
  9. *Change Proposal*—A written request by Contractor, duly submitted in compliance with the procedural requirements set forth herein, seeking an adjustment in Contract Price or Contract Times; contesting an initial decision by Engineer concerning the requirements of the Contract Documents or the acceptability of Work under the Contract Documents; challenging a set-off against payments due; or seeking other relief with respect to the terms of the Contract.
  10. *Claim*
    - a. A demand or assertion by Owner directly to Contractor, duly submitted in compliance with the procedural requirements set forth herein, seeking an adjustment of Contract Price or Contract Times; contesting an initial decision by Engineer concerning the



requirements of the Contract Documents or the acceptability of Work under the Contract Documents; contesting Engineer's decision regarding a Change Proposal; seeking resolution of a contractual issue that Engineer has declined to address; or seeking other relief with respect to the terms of the Contract.

- b. A demand or assertion by Contractor directly to Owner, duly submitted in compliance with the procedural requirements set forth herein, contesting Engineer's decision regarding a Change Proposal, or seeking resolution of a contractual issue that Engineer has declined to address.
  - c. A demand or assertion by Owner or Contractor, duly submitted in compliance with the procedural requirements set forth herein, made pursuant to Paragraph 12.01.A.4, concerning disputes arising after Engineer has issued a recommendation of final payment.
  - d. A demand for money or services by a third party is not a Claim.
11. *Constituent of Concern*—Asbestos, petroleum, radioactive materials, polychlorinated biphenyls (PCBs), lead-based paint (as defined by the HUD/EPA standard), hazardous waste, and any substance, product, waste, or other material of any nature whatsoever that is or becomes listed, regulated, or addressed pursuant to Laws and Regulations regulating, relating to, or imposing liability or standards of conduct concerning, any hazardous, toxic, or dangerous waste, substance, or material.
  12. *Contract*—The entire and integrated written contract between Owner and Contractor concerning the Work.
  13. *Contract Documents*—Those items so designated in the Agreement, and which together comprise the Contract.
  14. *Contract Price*—The money that Owner has agreed to pay Contractor for completion of the Work in accordance with the Contract Documents.
  15. *Contract Times*—The number of days or the dates by which Contractor shall: (a) achieve Milestones, if any; (b) achieve Substantial Completion; and (c) complete the Work.
  16. *Contractor*—The individual or entity with which Owner has contracted for performance of the Work.
  17. *Cost of the Work*—See Paragraph 13.01 for definition.
  18. *Drawings*—The part of the Contract that graphically shows the scope, extent, and character of the Work to be performed by Contractor.
  19. *Effective Date of the Contract*—The date, indicated in the Agreement, on which the Contract becomes effective.
  20. *Electronic Document*—Any Project-related correspondence, attachments to correspondence, data, documents, drawings, information, or graphics, including but not limited to Shop Drawings and other Submittals, that are in an electronic or digital format.
  21. *Electronic Means*—Electronic mail (email), upload/download from a secure Project website, or other communications methods that allow: (a) the transmission or communication of Electronic Documents; (b) the documentation of transmissions, including sending and receipt; (c) printing of the transmitted Electronic Document by the

recipient; (d) the storage and archiving of the Electronic Document by sender and recipient; and (e) the use by recipient of the Electronic Document for purposes permitted by this Contract. Electronic Means does not include the use of text messaging, or of Facebook, Twitter, Instagram, or similar social media services for transmission of Electronic Documents.

22. *Engineer*—The individual or entity named as such in the Agreement.
23. *Field Order*—A written order issued by Engineer which requires minor changes in the Work but does not change the Contract Price or the Contract Times.
24. *Hazardous Environmental Condition*—The presence at the Site of Constituents of Concern in such quantities or circumstances that may present a danger to persons or property exposed thereto.
  - a. The presence at the Site of materials that are necessary for the execution of the Work, or that are to be incorporated into the Work, and that are controlled and contained pursuant to industry practices, Laws and Regulations, and the requirements of the Contract, is not a Hazardous Environmental Condition.
  - b. The presence of Constituents of Concern that are to be removed or remediated as part of the Work is not a Hazardous Environmental Condition.
  - c. The presence of Constituents of Concern as part of the routine, anticipated, and obvious working conditions at the Site, is not a Hazardous Environmental Condition.
25. *Laws and Regulations; Laws or Regulations*—Any and all applicable laws, statutes, rules, regulations, ordinances, codes, and binding decrees, resolutions, and orders of any and all governmental bodies, agencies, authorities, and courts having jurisdiction.
26. *Liens*—Charges, security interests, or encumbrances upon Contract-related funds, real property, or personal property.
27. *Milestone*—A principal event in the performance of the Work that the Contract requires Contractor to achieve by an intermediate completion date, or by a time prior to Substantial Completion of all the Work.
28. *Notice of Award*—The written notice by Owner to a Bidder of Owner's acceptance of the Bid.
29. *Notice to Proceed*—A written notice by Owner to Contractor fixing the date on which the Contract Times will commence to run and on which Contractor shall start to perform the Work.
30. *Owner*—The individual or entity with which Contractor has contracted regarding the Work, and which has agreed to pay Contractor for the performance of the Work, pursuant to the terms of the Contract.
31. *Progress Schedule*—A schedule, prepared and maintained by Contractor, describing the sequence and duration of the activities comprising Contractor's plan to accomplish the Work within the Contract Times.
32. *Project*—The total undertaking to be accomplished for Owner by engineers, contractors, and others, including planning, study, design, construction, testing, commissioning, and start-up, and of which the Work to be performed under the Contract Documents is a part.

33. *Resident Project Representative*—The authorized representative of Engineer assigned to assist Engineer at the Site. As used herein, the term Resident Project Representative (RPR) includes any assistants or field staff of Resident Project Representative.
34. *Samples*—Physical examples of materials, equipment, or workmanship that are representative of some portion of the Work and that establish the standards by which such portion of the Work will be judged.
35. *Schedule of Submittals*—A schedule, prepared and maintained by Contractor, of required submittals and the time requirements for Engineer’s review of the submittals.
36. *Schedule of Values*—A schedule, prepared and maintained by Contractor, allocating portions of the Contract Price to various portions of the Work and used as the basis for reviewing Contractor’s Applications for Payment.
37. *Shop Drawings*—All drawings, diagrams, illustrations, schedules, and other data or information that are specifically prepared or assembled by or for Contractor and submitted by Contractor to illustrate some portion of the Work. Shop Drawings, whether approved or not, are not Drawings and are not Contract Documents.
38. *Site*—Lands or areas indicated in the Contract Documents as being furnished by Owner upon which the Work is to be performed, including rights-of-way and easements, and such other lands or areas furnished by Owner which are designated for the use of Contractor.
39. *Specifications*—The part of the Contract that consists of written requirements for materials, equipment, systems, standards, and workmanship as applied to the Work, and certain administrative requirements and procedural matters applicable to the Work.
40. *Subcontractor*—An individual or entity having a direct contract with Contractor or with any other Subcontractor for the performance of a part of the Work.
41. *Submittal*—A written or graphic document, prepared by or for Contractor, which the Contract Documents require Contractor to submit to Engineer, or that is indicated as a Submittal in the Schedule of Submittals accepted by Engineer. Submittals may include Shop Drawings and Samples; schedules; product data; Owner-delegated designs; sustainable design information; information on special procedures; testing plans; results of tests and evaluations, source quality-control testing and inspections, and field or Site quality-control testing and inspections; warranties and certifications; Suppliers’ instructions and reports; records of delivery of spare parts and tools; operations and maintenance data; Project photographic documentation; record documents; and other such documents required by the Contract Documents. Submittals, whether or not approved or accepted by Engineer, are not Contract Documents. Change Proposals, Change Orders, Claims, notices, Applications for Payment, and requests for interpretation or clarification are not Submittals.
42. *Substantial Completion*—The time at which the Work (or a specified part thereof) has progressed to the point where, in the opinion of Engineer, the Work (or a specified part thereof) is sufficiently complete, in accordance with the Contract Documents, so that the Work (or a specified part thereof) can be utilized for the purposes for which it is intended. The terms “substantially complete” and “substantially completed” as applied to all or part of the Work refer to Substantial Completion of such Work.

43. *Successful Bidder*—The Bidder to which the Owner makes an award of contract.
44. *Supplementary Conditions*—The part of the Contract that amends or supplements these General Conditions.
45. *Supplier*—A manufacturer, fabricator, supplier, distributor, or vendor having a direct contract with Contractor or with any Subcontractor to furnish materials or equipment to be incorporated in the Work by Contractor or a Subcontractor.
46. *Technical Data*
- a. Those items expressly identified as Technical Data in the Supplementary Conditions, with respect to either (1) existing subsurface conditions at or adjacent to the Site, or existing physical conditions at or adjacent to the Site including existing surface or subsurface structures (except Underground Facilities) or (2) Hazardous Environmental Conditions at the Site.
  - b. If no such express identifications of Technical Data have been made with respect to conditions at the Site, then Technical Data is defined, with respect to conditions at the Site under Paragraphs 5.03, 5.04, and 5.06, as the data contained in boring logs, recorded measurements of subsurface water levels, assessments of the condition of subsurface facilities, laboratory test results, and other factual, objective information regarding conditions at the Site that are set forth in any geotechnical, environmental, or other Site or facilities conditions report prepared for the Project and made available to Contractor.
  - c. Information and data regarding the presence or location of Underground Facilities are not intended to be categorized, identified, or defined as Technical Data, and instead Underground Facilities are shown or indicated on the Drawings.
47. *Underground Facilities*—All active or not-in-service underground lines, pipelines, conduits, ducts, encasements, cables, wires, manholes, vaults, tanks, tunnels, or other such facilities or systems at the Site, including but not limited to those facilities or systems that produce, transmit, distribute, or convey telephone or other communications, cable television, fiber optic transmissions, power, electricity, light, heat, gases, oil, crude oil products, liquid petroleum products, water, steam, waste, wastewater, storm water, other liquids or chemicals, or traffic or other control systems. An abandoned facility or system is not an Underground Facility.
48. *Unit Price Work*—Work to be paid for on the basis of unit prices.
49. *Work*—The entire construction or the various separately identifiable parts thereof required to be provided under the Contract Documents. Work includes and is the result of performing or providing all labor, services, and documentation necessary to produce such construction; furnishing, installing, and incorporating all materials and equipment into such construction; and may include related services such as testing, start-up, and commissioning, all as required by the Contract Documents.
50. *Work Change Directive*—A written directive to Contractor issued on or after the Effective Date of the Contract, signed by Owner and recommended by Engineer, ordering an addition, deletion, or revision in the Work.

## 1.02 Terminology

- A. The words and terms discussed in Paragraphs 1.02.B, C, D, and E are not defined terms that require initial capital letters, but, when used in the Bidding Requirements or Contract Documents, have the indicated meaning.
- B. *Intent of Certain Terms or Adjectives:* The Contract Documents include the terms “as allowed,” “as approved,” “as ordered,” “as directed” or terms of like effect or import to authorize an exercise of professional judgment by Engineer. In addition, the adjectives “reasonable,” “suitable,” “acceptable,” “proper,” “satisfactory,” or adjectives of like effect or import are used to describe an action or determination of Engineer as to the Work. It is intended that such exercise of professional judgment, action, or determination will be solely to evaluate, in general, the Work for compliance with the information in the Contract Documents and with the design concept of the Project as a functioning whole as shown or indicated in the Contract Documents (unless there is a specific statement indicating otherwise). The use of any such term or adjective is not intended to and shall not be effective to assign to Engineer any duty or authority to supervise or direct the performance of the Work, or any duty or authority to undertake responsibility contrary to the provisions of Article 10 or any other provision of the Contract Documents.
- C. *Day:* The word “day” means a calendar day of 24 hours measured from midnight to the next midnight.
- D. *Defective:* The word “defective,” when modifying the word “Work,” refers to Work that is unsatisfactory, faulty, or deficient in that it:
1. does not conform to the Contract Documents;
  2. does not meet the requirements of any applicable inspection, reference standard, test, or approval referred to in the Contract Documents; or
  3. has been damaged prior to Engineer’s recommendation of final payment (unless responsibility for the protection thereof has been assumed by Owner at Substantial Completion in accordance with Paragraph 15.03 or Paragraph 15.04).
- E. *Furnish, Install, Perform, Provide*
1. The word “furnish,” when used in connection with services, materials, or equipment, means to supply and deliver said services, materials, or equipment to the Site (or some other specified location) ready for use or installation and in usable or operable condition.
  2. The word “install,” when used in connection with services, materials, or equipment, means to put into use or place in final position said services, materials, or equipment complete and ready for intended use.
  3. The words “perform” or “provide,” when used in connection with services, materials, or equipment, means to furnish and install said services, materials, or equipment complete and ready for intended use.
  4. If the Contract Documents establish an obligation of Contractor with respect to specific services, materials, or equipment, but do not expressly use any of the four words “furnish,” “install,” “perform,” or “provide,” then Contractor shall furnish and install said services, materials, or equipment complete and ready for intended use.

- F. *Contract Price or Contract Times*: References to a change in “Contract Price or Contract Times” or “Contract Times or Contract Price” or similar, indicate that such change applies to (1) Contract Price, (2) Contract Times, or (3) both Contract Price and Contract Times, as warranted, even if the term “or both” is not expressed.
- G. Unless stated otherwise in the Contract Documents, words or phrases that have a well-known technical or construction industry or trade meaning are used in the Contract Documents in accordance with such recognized meaning.

## ARTICLE 2—PRELIMINARY MATTERS

### 2.01 *Delivery of Performance and Payment Bonds; Evidence of Insurance*

- A. *Performance and Payment Bonds*: When Contractor delivers the signed counterparts of the Agreement to Owner, Contractor shall also deliver to Owner the performance bond and payment bond (if the Contract requires Contractor to furnish such bonds).
- B. *Evidence of Contractor’s Insurance*: When Contractor delivers the signed counterparts of the Agreement to Owner, Contractor shall also deliver to Owner, with copies to each additional insured (as identified in the Contract), the certificates, endorsements, and other evidence of insurance required to be provided by Contractor in accordance with Article 6, except to the extent the Supplementary Conditions expressly establish other dates for delivery of specific insurance policies.
- C. *Evidence of Owner’s Insurance*: After receipt of the signed counterparts of the Agreement and all required bonds and insurance documentation, Owner shall promptly deliver to Contractor, with copies to each additional insured (as identified in the Contract), the certificates and other evidence of insurance required to be provided by Owner under Article 6.

### 2.02 *Copies of Documents*

- A. Owner shall furnish to Contractor four printed copies of the Contract (including one fully signed counterpart of the Agreement), and one copy in electronic portable document format (PDF). Additional printed copies will be furnished upon request at the cost of reproduction.
- B. Owner shall maintain and safeguard at least one original printed record version of the Contract, including Drawings and Specifications signed and sealed by Engineer and other design professionals. Owner shall make such original printed record version of the Contract available to Contractor for review. Owner may delegate the responsibilities under this provision to Engineer.

### 2.03 *Before Starting Construction*

- A. *Preliminary Schedules*: Within 10 days after the Effective Date of the Contract (or as otherwise required by the Contract Documents), Contractor shall submit to Engineer for timely review:
  - 1. a preliminary Progress Schedule indicating the times (numbers of days or dates) for starting and completing the various stages of the Work, including any Milestones specified in the Contract;
  - 2. a preliminary Schedule of Submittals; and
  - 3. a preliminary Schedule of Values for all of the Work which includes quantities and prices of items which when added together equal the Contract Price and subdivides the Work

into component parts in sufficient detail to serve as the basis for progress payments during performance of the Work. Such prices will include an appropriate amount of overhead and profit applicable to each item of Work.

2.04 *Preconstruction Conference; Designation of Authorized Representatives*

- A. Before any Work at the Site is started, a conference attended by Owner, Contractor, Engineer, and others as appropriate will be held to establish a working understanding among the parties as to the Work, and to discuss the schedules referred to in Paragraph 2.03.A, procedures for handling Shop Drawings, Samples, and other Submittals, processing Applications for Payment, electronic or digital transmittals, and maintaining required records.
- B. At this conference Owner and Contractor each shall designate, in writing, a specific individual to act as its authorized representative with respect to the services and responsibilities under the Contract. Such individuals shall have the authority to transmit and receive information, render decisions relative to the Contract, and otherwise act on behalf of each respective party.

2.05 *Acceptance of Schedules*

- A. At least 10 days before submission of the first Application for Payment a conference, attended by Contractor, Engineer, and others as appropriate, will be held to review the schedules submitted in accordance with Paragraph 2.03.A. No progress payment will be made to Contractor until acceptable schedules are submitted to Engineer.
  - 1. The Progress Schedule will be acceptable to Engineer if it provides an orderly progression of the Work to completion within the Contract Times. Such acceptance will not impose on Engineer responsibility for the Progress Schedule, for sequencing, scheduling, or progress of the Work, nor interfere with or relieve Contractor from Contractor's full responsibility therefor.
  - 2. Contractor's Schedule of Submittals will be acceptable to Engineer if it provides a workable arrangement for reviewing and processing the required submittals.
  - 3. Contractor's Schedule of Values will be acceptable to Engineer as to form and substance if it provides a reasonable allocation of the Contract Price to the component parts of the Work.
  - 4. If a schedule is not acceptable, Contractor will have an additional 10 days to revise and resubmit the schedule.

2.06 *Electronic Transmittals*

- A. Except as otherwise stated elsewhere in the Contract, the Owner, Engineer, and Contractor may send, and shall accept, Electronic Documents transmitted by Electronic Means.
- B. If the Contract does not establish protocols for Electronic Means, then Owner, Engineer, and Contractor shall jointly develop such protocols.
- C. Subject to any governing protocols for Electronic Means, when transmitting Electronic Documents by Electronic Means, the transmitting party makes no representations as to long-term compatibility, usability, or readability of the Electronic Documents resulting from the recipient's use of software application packages, operating systems, or computer hardware differing from those used in the drafting or transmittal of the Electronic Documents.



**ARTICLE 3—CONTRACT DOCUMENTS: INTENT, REQUIREMENTS, REUSE**

3.01 *Intent*

- A. The Contract Documents are complementary; what is required by one Contract Document is as binding as if required by all.
- B. It is the intent of the Contract Documents to describe a functionally complete Project (or part thereof) to be constructed in accordance with the Contract Documents.
- C. Unless otherwise stated in the Contract Documents, if there is a discrepancy between the electronic versions of the Contract Documents (including any printed copies derived from such electronic versions) and the printed record version, the printed record version will govern.
- D. The Contract supersedes prior negotiations, representations, and agreements, whether written or oral.
- E. Engineer will issue clarifications and interpretations of the Contract Documents as provided herein.
- F. Any provision or part of the Contract Documents held to be void or unenforceable under any Law or Regulation will be deemed stricken, and all remaining provisions will continue to be valid and binding upon Owner and Contractor, which agree that the Contract Documents will be reformed to replace such stricken provision or part thereof with a valid and enforceable provision that comes as close as possible to expressing the intention of the stricken provision.
- G. Nothing in the Contract Documents creates:
  - 1. any contractual relationship between Owner or Engineer and any Subcontractor, Supplier, or other individual or entity performing or furnishing any of the Work, for the benefit of such Subcontractor, Supplier, or other individual or entity; or
  - 2. any obligation on the part of Owner or Engineer to pay or to see to the payment of any money due any such Subcontractor, Supplier, or other individual or entity, except as may otherwise be required by Laws and Regulations.

3.02 *Reference Standards*

- A. *Standards Specifications, Codes, Laws and Regulations*
  - 1. Reference in the Contract Documents to standard specifications, manuals, reference standards, or codes of any technical society, organization, or association, or to Laws or Regulations, whether such reference be specific or by implication, means the standard specification, manual, reference standard, code, or Laws or Regulations in effect at the time of opening of Bids (or on the Effective Date of the Contract if there were no Bids), except as may be otherwise specifically stated in the Contract Documents.
  - 2. No provision of any such standard specification, manual, reference standard, or code, and no instruction of a Supplier, will be effective to change the duties or responsibilities of Owner, Contractor, or Engineer from those set forth in the part of the Contract Documents prepared by or for Engineer. No such provision or instruction shall be effective to assign to Owner or Engineer any duty or authority to supervise or direct the performance of the Work, or any duty or authority to undertake responsibility

inconsistent with the provisions of the part of the Contract Documents prepared by or for Engineer.

### 3.03 *Reporting and Resolving Discrepancies*

#### A. *Reporting Discrepancies*

1. *Contractor's Verification of Figures and Field Measurements:* Before undertaking each part of the Work, Contractor shall carefully study the Contract Documents, and check and verify pertinent figures and dimensions therein, particularly with respect to applicable field measurements. Contractor shall promptly report in writing to Engineer any conflict, error, ambiguity, or discrepancy that Contractor discovers, or has actual knowledge of, and shall not proceed with any Work affected thereby until the conflict, error, ambiguity, or discrepancy is resolved by a clarification or interpretation by Engineer, or by an amendment or supplement to the Contract issued pursuant to Paragraph 11.01.
2. *Contractor's Review of Contract Documents:* If, before or during the performance of the Work, Contractor discovers any conflict, error, ambiguity, or discrepancy within the Contract Documents, or between the Contract Documents and (a) any applicable Law or Regulation, (b) actual field conditions, (c) any standard specification, manual, reference standard, or code, or (d) any instruction of any Supplier, then Contractor shall promptly report it to Engineer in writing. Contractor shall not proceed with the Work affected thereby (except in an emergency as required by Paragraph 7.15) until the conflict, error, ambiguity, or discrepancy is resolved, by a clarification or interpretation by Engineer, or by an amendment or supplement to the Contract issued pursuant to Paragraph 11.01.
3. Contractor shall not be liable to Owner or Engineer for failure to report any conflict, error, ambiguity, or discrepancy in the Contract Documents unless Contractor had actual knowledge thereof.

#### B. *Resolving Discrepancies*

1. Except as may be otherwise specifically stated in the Contract Documents, the provisions of the part of the Contract Documents prepared by or for Engineer take precedence in resolving any conflict, error, ambiguity, or discrepancy between such provisions of the Contract Documents and:
  - a. the provisions of any standard specification, manual, reference standard, or code, or the instruction of any Supplier (whether or not specifically incorporated by reference as a Contract Document); or
  - b. the provisions of any Laws or Regulations applicable to the performance of the Work (unless such an interpretation of the provisions of the Contract Documents would result in violation of such Law or Regulation).

### 3.04 *Requirements of the Contract Documents*

- A. During the performance of the Work and until final payment, Contractor and Owner shall submit to the Engineer in writing all matters in question concerning the requirements of the Contract Documents (sometimes referred to as requests for information or interpretation—RFIs), or relating to the acceptability of the Work under the Contract Documents, as soon as possible after such matters arise. Engineer will be the initial interpreter of the requirements of the Contract Documents, and judge of the acceptability of the Work.

- B. Engineer will, with reasonable promptness, render a written clarification, interpretation, or decision on the issue submitted, or initiate an amendment or supplement to the Contract Documents. Engineer's written clarification, interpretation, or decision will be final and binding on Contractor, unless it appeals by submitting a Change Proposal, and on Owner, unless it appeals by filing a Claim.
- C. If a submitted matter in question concerns terms and conditions of the Contract Documents that do not involve (1) the performance or acceptability of the Work under the Contract Documents, (2) the design (as set forth in the Drawings, Specifications, or otherwise), or (3) other engineering or technical matters, then Engineer will promptly notify Owner and Contractor in writing that Engineer is unable to provide a decision or interpretation. If Owner and Contractor are unable to agree on resolution of such a matter in question, either party may pursue resolution as provided in Article 12.

3.05 *Reuse of Documents*

- A. Contractor and its Subcontractors and Suppliers shall not:
  - 1. have or acquire any title to or ownership rights in any of the Drawings, Specifications, or other documents (or copies of any thereof) prepared by or bearing the seal of Engineer or its consultants, including electronic media versions, or reuse any such Drawings, Specifications, other documents, or copies thereof on extensions of the Project or any other project without written consent of Owner and Engineer and specific written verification or adaptation by Engineer; or
  - 2. have or acquire any title or ownership rights in any other Contract Documents, reuse any such Contract Documents for any purpose without Owner's express written consent, or violate any copyrights pertaining to such Contract Documents.
- B. The prohibitions of this Paragraph 3.05 will survive final payment, or termination of the Contract. Nothing herein precludes Contractor from retaining copies of the Contract Documents for record purposes.

**ARTICLE 4—COMMENCEMENT AND PROGRESS OF THE WORK**

4.01 *Commencement of Contract Times; Notice to Proceed*

- A. The Contract Times will commence to run on the 30th day after the Effective Date of the Contract or, if a Notice to Proceed is given, on the day indicated in the Notice to Proceed. A Notice to Proceed may be given at any time within 30 days after the Effective Date of the Contract. In no event will the Contract Times commence to run later than the 60th day after the day of Bid opening or the 30th day after the Effective Date of the Contract, whichever date is earlier.

4.02 *Starting the Work*

- A. Contractor shall start to perform the Work on the date when the Contract Times commence to run. No Work may be done at the Site prior to such date.

4.03 *Reference Points*

- A. Owner shall provide engineering surveys to establish reference points for construction which in Engineer's judgment are necessary to enable Contractor to proceed with the Work. Contractor shall be responsible for laying out the Work, shall protect and preserve the

established reference points and property monuments, and shall make no changes or relocations without the prior written approval of Owner. Contractor shall report to Engineer whenever any reference point or property monument is lost or destroyed or requires relocation because of necessary changes in grades or locations, and shall be responsible for the accurate replacement or relocation of such reference points or property monuments by professionally qualified personnel.

#### 4.04 *Progress Schedule*

- A. Contractor shall adhere to the Progress Schedule established in accordance with Paragraph 2.05 as it may be adjusted from time to time as provided below.
  - 1. Contractor shall submit to Engineer for acceptance (to the extent indicated in Paragraph 2.05) proposed adjustments in the Progress Schedule that will not result in changing the Contract Times.
  - 2. Proposed adjustments in the Progress Schedule that will change the Contract Times must be submitted in accordance with the requirements of Article 11.
- B. Contractor shall carry on the Work and adhere to the Progress Schedule during all disputes or disagreements with Owner. No Work will be delayed or postponed pending resolution of any disputes or disagreements, or during any appeal process, except as permitted by Paragraph 16.04, or as Owner and Contractor may otherwise agree in writing.

#### 4.05 *Delays in Contractor's Progress*

- A. If Owner, Engineer, or anyone for whom Owner is responsible, delays, disrupts, or interferes with the performance or progress of the Work, then Contractor shall be entitled to an equitable adjustment in Contract Price or Contract Times.
- B. Contractor shall not be entitled to an adjustment in Contract Price or Contract Times for delay, disruption, or interference caused by or within the control of Contractor. Delay, disruption, and interference attributable to and within the control of a Subcontractor or Supplier shall be deemed to be within the control of Contractor.
- C. If Contractor's performance or progress is delayed, disrupted, or interfered with by unanticipated causes not the fault of and beyond the control of Owner, Contractor, and those for which they are responsible, then Contractor shall be entitled to an equitable adjustment in Contract Times. Such an adjustment will be Contractor's sole and exclusive remedy for the delays, disruption, and interference described in this paragraph. Causes of delay, disruption, or interference that may give rise to an adjustment in Contract Times under this paragraph include but are not limited to the following:
  - 1. Severe and unavoidable natural catastrophes such as fires, floods, epidemics, and earthquakes;
  - 2. Abnormal weather conditions;
  - 3. Acts or failures to act of third-party utility owners or other third-party entities (other than those third-party utility owners or other third-party entities performing other work at or adjacent to the Site as arranged by or under contract with Owner, as contemplated in Article 8); and
  - 4. Acts of war or terrorism.

- D. Contractor's entitlement to an adjustment of Contract Times or Contract Price is limited as follows:
1. Contractor's entitlement to an adjustment of the Contract Times is conditioned on the delay, disruption, or interference adversely affecting an activity on the critical path to completion of the Work, as of the time of the delay, disruption, or interference.
  2. Contractor shall not be entitled to an adjustment in Contract Price for any delay, disruption, or interference if such delay is concurrent with a delay, disruption, or interference caused by or within the control of Contractor. Such a concurrent delay by Contractor shall not preclude an adjustment of Contract Times to which Contractor is otherwise entitled.
  3. Adjustments of Contract Times or Contract Price are subject to the provisions of Article 11.
- E. Each Contractor request or Change Proposal seeking an increase in Contract Times or Contract Price must be supplemented by supporting data that sets forth in detail the following:
1. The circumstances that form the basis for the requested adjustment;
  2. The date upon which each cause of delay, disruption, or interference began to affect the progress of the Work;
  3. The date upon which each cause of delay, disruption, or interference ceased to affect the progress of the Work;
  4. The number of days' increase in Contract Times claimed as a consequence of each such cause of delay, disruption, or interference; and
  5. The impact on Contract Price, in accordance with the provisions of Paragraph 11.07.
- Contractor shall also furnish such additional supporting documentation as Owner or Engineer may require including, where appropriate, a revised progress schedule indicating all the activities affected by the delay, disruption, or interference, and an explanation of the effect of the delay, disruption, or interference on the critical path to completion of the Work.
- F. Delays, disruption, and interference to the performance or progress of the Work resulting from the existence of a differing subsurface or physical condition, an Underground Facility that was not shown or indicated by the Contract Documents, or not shown or indicated with reasonable accuracy, and those resulting from Hazardous Environmental Conditions, are governed by Article 5, together with the provisions of Paragraphs 4.05.D and 4.05.E.
- G. Paragraph 8.03 addresses delays, disruption, and interference to the performance or progress of the Work resulting from the performance of certain other work at or adjacent to the Site.

## **ARTICLE 5—SITE; SUBSURFACE AND PHYSICAL CONDITIONS; HAZARDOUS ENVIRONMENTAL CONDITIONS**

### *5.01 Availability of Lands*

- A. Owner shall furnish the Site. Owner shall notify Contractor in writing of any encumbrances or restrictions not of general application but specifically related to use of the Site with which Contractor must comply in performing the Work.

- B. Upon reasonable written request, Owner shall furnish Contractor with a current statement of record legal title and legal description of the lands upon which permanent improvements are to be made and Owner's interest therein as necessary for giving notice of or filing a mechanic's or construction lien against such lands in accordance with applicable Laws and Regulations.
- C. Contractor shall provide for all additional lands and access thereto that may be required for temporary construction facilities or storage of materials and equipment.

5.02 *Use of Site and Other Areas*

A. *Limitation on Use of Site and Other Areas*

- 1. Contractor shall confine construction equipment, temporary construction facilities, the storage of materials and equipment, and the operations of workers to the Site, adjacent areas that Contractor has arranged to use through construction easements or otherwise, and other adjacent areas permitted by Laws and Regulations, and shall not unreasonably encumber the Site and such other adjacent areas with construction equipment or other materials or equipment. Contractor shall assume full responsibility for (a) damage to the Site; (b) damage to any such other adjacent areas used for Contractor's operations; (c) damage to any other adjacent land or areas, or to improvements, structures, utilities, or similar facilities located at such adjacent lands or areas; and (d) for injuries and losses sustained by the owners or occupants of any such land or areas; provided that such damage or injuries result from the performance of the Work or from other actions or conduct of the Contractor or those for which Contractor is responsible.
  - 2. If a damage or injury claim is made by the owner or occupant of any such land or area because of the performance of the Work, or because of other actions or conduct of the Contractor or those for which Contractor is responsible, Contractor shall (a) take immediate corrective or remedial action as required by Paragraph 7.13, or otherwise; (b) promptly attempt to settle the claim as to all parties through negotiations with such owner or occupant, or otherwise resolve the claim by arbitration or other dispute resolution proceeding, or in a court of competent jurisdiction; and (c) to the fullest extent permitted by Laws and Regulations, indemnify and hold harmless Owner and Engineer, and the officers, directors, members, partners, employees, agents, consultants and subcontractors of each and any of them, from and against any such claim, and against all costs, losses, and damages (including but not limited to all fees and charges of engineers, architects, attorneys, and other professionals and all court or arbitration or other dispute resolution costs) arising out of or relating to any claim or action, legal or equitable, brought by any such owner or occupant against Owner, Engineer, or any other party indemnified hereunder to the extent caused directly or indirectly, in whole or in part by, or based upon, Contractor's performance of the Work, or because of other actions or conduct of the Contractor or those for which Contractor is responsible.
- B. *Removal of Debris During Performance of the Work:* During the progress of the Work the Contractor shall keep the Site and other adjacent areas free from accumulations of waste materials, rubbish, and other debris. Removal and disposal of such waste materials, rubbish, and other debris will conform to applicable Laws and Regulations.
  - C. *Cleaning:* Prior to Substantial Completion of the Work Contractor shall clean the Site and the Work and make it ready for utilization by Owner. At the completion of the Work Contractor shall remove from the Site and adjacent areas all tools, appliances, construction equipment

and machinery, and surplus materials and shall restore to original condition all property not designated for alteration by the Contract Documents.

- D. *Loading of Structures*: Contractor shall not load nor permit any part of any structure to be loaded in any manner that will endanger the structure, nor shall Contractor subject any part of the Work or adjacent structures or land to stresses or pressures that will endanger them.

#### 5.03 *Subsurface and Physical Conditions*

- A. *Reports and Drawings*: The Supplementary Conditions identify:
  - 1. Those reports of explorations and tests of subsurface conditions at or adjacent to the Site that contain Technical Data;
  - 2. Those drawings of existing physical conditions at or adjacent to the Site, including those drawings depicting existing surface or subsurface structures at or adjacent to the Site (except Underground Facilities), that contain Technical Data; and
  - 3. Technical Data contained in such reports and drawings.
- B. *Underground Facilities*: Underground Facilities are shown or indicated on the Drawings, pursuant to Paragraph 5.05, and not in the drawings referred to in Paragraph 5.03.A. Information and data regarding the presence or location of Underground Facilities are not intended to be categorized, identified, or defined as Technical Data.
- C. *Reliance by Contractor on Technical Data*: Contractor may rely upon the accuracy of the Technical Data expressly identified in the Supplementary Conditions with respect to such reports and drawings, but such reports and drawings are not Contract Documents. If no such express identification has been made, then Contractor may rely upon the accuracy of the Technical Data as defined in Paragraph 1.01.A.46.b.
- D. *Limitations of Other Data and Documents*: Except for such reliance on Technical Data, Contractor may not rely upon or make any claim against Owner or Engineer, or any of their officers, directors, members, partners, employees, agents, consultants, or subcontractors, with respect to:
  - 1. the completeness of such reports and drawings for Contractor's purposes, including, but not limited to, any aspects of the means, methods, techniques, sequences, and procedures of construction to be employed by Contractor, and safety precautions and programs incident thereto;
  - 2. other data, interpretations, opinions, and information contained in such reports or shown or indicated in such drawings;
  - 3. the contents of other Site-related documents made available to Contractor, such as record drawings from other projects at or adjacent to the Site, or Owner's archival documents concerning the Site; or
  - 4. any Contractor interpretation of or conclusion drawn from any Technical Data or any such other data, interpretations, opinions, or information.



5.04 *Differing Subsurface or Physical Conditions*

- A. *Notice by Contractor:* If Contractor believes that any subsurface or physical condition that is uncovered or revealed at the Site:
1. is of such a nature as to establish that any Technical Data on which Contractor is entitled to rely as provided in Paragraph 5.03 is materially inaccurate;
  2. is of such a nature as to require a change in the Drawings or Specifications;
  3. differs materially from that shown or indicated in the Contract Documents; or
  4. is of an unusual nature, and differs materially from conditions ordinarily encountered and generally recognized as inherent in work of the character provided for in the Contract Documents;

then Contractor shall, promptly after becoming aware thereof and before further disturbing the subsurface or physical conditions or performing any Work in connection therewith (except in an emergency as required by Paragraph 7.15), notify Owner and Engineer in writing about such condition. Contractor shall not further disturb such condition or perform any Work in connection therewith (except with respect to an emergency) until receipt of a written statement permitting Contractor to do so.

- B. *Engineer's Review:* After receipt of written notice as required by the preceding paragraph, Engineer will promptly review the subsurface or physical condition in question; determine whether it is necessary for Owner to obtain additional exploration or tests with respect to the condition; conclude whether the condition falls within any one or more of the differing site condition categories in Paragraph 5.04.A; obtain any pertinent cost or schedule information from Contractor; prepare recommendations to Owner regarding the Contractor's resumption of Work in connection with the subsurface or physical condition in question and the need for any change in the Drawings or Specifications; and advise Owner in writing of Engineer's findings, conclusions, and recommendations.
- C. *Owner's Statement to Contractor Regarding Site Condition:* After receipt of Engineer's written findings, conclusions, and recommendations, Owner shall issue a written statement to Contractor (with a copy to Engineer) regarding the subsurface or physical condition in question, addressing the resumption of Work in connection with such condition, indicating whether any change in the Drawings or Specifications will be made, and adopting or rejecting Engineer's written findings, conclusions, and recommendations, in whole or in part.
- D. *Early Resumption of Work:* If at any time Engineer determines that Work in connection with the subsurface or physical condition in question may resume prior to completion of Engineer's review or Owner's issuance of its statement to Contractor, because the condition in question has been adequately documented, and analyzed on a preliminary basis, then the Engineer may at its discretion instruct Contractor to resume such Work.
- E. *Possible Price and Times Adjustments*
1. Contractor shall be entitled to an equitable adjustment in Contract Price or Contract Times, to the extent that the existence of a differing subsurface or physical condition, or any related delay, disruption, or interference, causes an increase or decrease in

Contractor's cost of, or time required for, performance of the Work; subject, however, to the following:

- a. Such condition must fall within any one or more of the categories described in Paragraph 5.04.A;
  - b. With respect to Work that is paid for on a unit price basis, any adjustment in Contract Price will be subject to the provisions of Paragraph 13.03; and,
  - c. Contractor's entitlement to an adjustment of the Contract Times is subject to the provisions of Paragraphs 4.05.D and 4.05.E.
2. Contractor shall not be entitled to any adjustment in the Contract Price or Contract Times with respect to a subsurface or physical condition if:
- a. Contractor knew of the existence of such condition at the time Contractor made a commitment to Owner with respect to Contract Price and Contract Times by the submission of a Bid or becoming bound under a negotiated contract, or otherwise;
  - b. The existence of such condition reasonably could have been discovered or revealed as a result of any examination, investigation, exploration, test, or study of the Site and contiguous areas expressly required by the Bidding Requirements or Contract Documents to be conducted by or for Contractor prior to Contractor's making such commitment; or
  - c. Contractor failed to give the written notice required by Paragraph 5.04.A.
3. If Owner and Contractor agree regarding Contractor's entitlement to and the amount or extent of any adjustment in the Contract Price or Contract Times, then any such adjustment will be set forth in a Change Order.
4. Contractor may submit a Change Proposal regarding its entitlement to or the amount or extent of any adjustment in the Contract Price or Contract Times, no later than 30 days after Owner's issuance of the Owner's written statement to Contractor regarding the subsurface or physical condition in question.
- F. *Underground Facilities; Hazardous Environmental Conditions:* Paragraph 5.05 governs rights and responsibilities regarding the presence or location of Underground Facilities. Paragraph 5.06 governs rights and responsibilities regarding Hazardous Environmental Conditions. The provisions of Paragraphs 5.03 and 5.04 are not applicable to the presence or location of Underground Facilities, or to Hazardous Environmental Conditions.

5.05 *Underground Facilities*

- A. *Contractor's Responsibilities:* Unless it is otherwise expressly provided in the Supplementary Conditions, the cost of all of the following are included in the Contract Price, and Contractor shall have full responsibility for:
1. reviewing and checking all information and data regarding existing Underground Facilities at the Site;
  2. complying with applicable state and local utility damage prevention Laws and Regulations;

3. verifying the actual location of those Underground Facilities shown or indicated in the Contract Documents as being within the area affected by the Work, by exposing such Underground Facilities during the course of construction;
  4. coordination of the Work with the owners (including Owner) of such Underground Facilities, during construction; and
  5. the safety and protection of all existing Underground Facilities at the Site, and repairing any damage thereto resulting from the Work.
- B. *Notice by Contractor:* If Contractor believes that an Underground Facility that is uncovered or revealed at the Site was not shown or indicated on the Drawings, or was not shown or indicated on the Drawings with reasonable accuracy, then Contractor shall, promptly after becoming aware thereof and before further disturbing conditions affected thereby or performing any Work in connection therewith (except in an emergency as required by Paragraph 7.15), notify Owner and Engineer in writing regarding such Underground Facility.
- C. *Engineer's Review:* Engineer will:
1. promptly review the Underground Facility and conclude whether such Underground Facility was not shown or indicated on the Drawings, or was not shown or indicated with reasonable accuracy;
  2. identify and communicate with the owner of the Underground Facility; prepare recommendations to Owner (and if necessary issue any preliminary instructions to Contractor) regarding the Contractor's resumption of Work in connection with the Underground Facility in question;
  3. obtain any pertinent cost or schedule information from Contractor; determine the extent, if any, to which a change is required in the Drawings or Specifications to reflect and document the consequences of the existence or location of the Underground Facility; and
  4. advise Owner in writing of Engineer's findings, conclusions, and recommendations.
- During such time, Contractor shall be responsible for the safety and protection of such Underground Facility.
- D. *Owner's Statement to Contractor Regarding Underground Facility:* After receipt of Engineer's written findings, conclusions, and recommendations, Owner shall issue a written statement to Contractor (with a copy to Engineer) regarding the Underground Facility in question addressing the resumption of Work in connection with such Underground Facility, indicating whether any change in the Drawings or Specifications will be made, and adopting or rejecting Engineer's written findings, conclusions, and recommendations in whole or in part.
- E. *Early Resumption of Work:* If at any time Engineer determines that Work in connection with the Underground Facility may resume prior to completion of Engineer's review or Owner's issuance of its statement to Contractor, because the Underground Facility in question and conditions affected by its presence have been adequately documented, and analyzed on a preliminary basis, then the Engineer may at its discretion instruct Contractor to resume such Work.
- F. *Possible Price and Times Adjustments*
1. Contractor shall be entitled to an equitable adjustment in the Contract Price or Contract Times, to the extent that any existing Underground Facility at the Site that was not shown

or indicated on the Drawings, or was not shown or indicated with reasonable accuracy, or any related delay, disruption, or interference, causes an increase or decrease in Contractor's cost of, or time required for, performance of the Work; subject, however, to the following:

- a. With respect to Work that is paid for on a unit price basis, any adjustment in Contract Price will be subject to the provisions of Paragraph 13.03;
  - b. Contractor's entitlement to an adjustment of the Contract Times is subject to the provisions of Paragraphs 4.05.D and 4.05.E; and
  - c. Contractor gave the notice required in Paragraph 5.05.B.
2. If Owner and Contractor agree regarding Contractor's entitlement to and the amount or extent of any adjustment in the Contract Price or Contract Times, then any such adjustment will be set forth in a Change Order.
  3. Contractor may submit a Change Proposal regarding its entitlement to or the amount or extent of any adjustment in the Contract Price or Contract Times, no later than 30 days after Owner's issuance of the Owner's written statement to Contractor regarding the Underground Facility in question.
  4. The information and data shown or indicated on the Drawings with respect to existing Underground Facilities at the Site is based on information and data (a) furnished by the owners of such Underground Facilities, or by others, (b) obtained from available records, or (c) gathered in an investigation conducted in accordance with the current edition of ASCE 38, Standard Guideline for the Collection and Depiction of Existing Subsurface Utility Data, by the American Society of Civil Engineers. If such information or data is incorrect or incomplete, Contractor's remedies are limited to those set forth in this Paragraph 5.05.F.

5.06 *Hazardous Environmental Conditions at Site*

- A. *Reports and Drawings:* The Supplementary Conditions identify:
  1. those reports known to Owner relating to Hazardous Environmental Conditions that have been identified at or adjacent to the Site;
  2. drawings known to Owner relating to Hazardous Environmental Conditions that have been identified at or adjacent to the Site; and
  3. Technical Data contained in such reports and drawings.
- B. *Reliance by Contractor on Technical Data Authorized:* Contractor may rely upon the accuracy of the Technical Data expressly identified in the Supplementary Conditions with respect to such reports and drawings, but such reports and drawings are not Contract Documents. If no such express identification has been made, then Contractor may rely on the accuracy of the Technical Data as defined in Paragraph 1.01.A.46.b. Except for such reliance on Technical Data, Contractor may not rely upon or make any claim against Owner or Engineer, or any of their officers, directors, members, partners, employees, agents, consultants, or subcontractors, with respect to:
  1. the completeness of such reports and drawings for Contractor's purposes, including, but not limited to, any aspects of the means, methods, techniques, sequences and procedures

- of construction to be employed by Contractor, and safety precautions and programs incident thereto;
2. other data, interpretations, opinions, and information contained in such reports or shown or indicated in such drawings; or
  3. any Contractor interpretation of or conclusion drawn from any Technical Data or any such other data, interpretations, opinions or information.
- C. Contractor shall not be responsible for removing or remediating any Hazardous Environmental Condition encountered, uncovered, or revealed at the Site unless such removal or remediation is expressly identified in the Contract Documents to be within the scope of the Work.
- D. Contractor shall be responsible for controlling, containing, and duly removing all Constituents of Concern brought to the Site by Contractor, Subcontractors, Suppliers, or anyone else for whom Contractor is responsible, and for any associated costs; and for the costs of removing and remediating any Hazardous Environmental Condition created by the presence of any such Constituents of Concern.
- E. If Contractor encounters, uncovers, or reveals a Hazardous Environmental Condition whose removal or remediation is not expressly identified in the Contract Documents as being within the scope of the Work, or if Contractor or anyone for whom Contractor is responsible creates a Hazardous Environmental Condition, then Contractor shall immediately: (1) secure or otherwise isolate such condition; (2) stop all Work in connection with such condition and in any area affected thereby (except in an emergency as required by Paragraph 7.15); and (3) notify Owner and Engineer (and promptly thereafter confirm such notice in writing). Owner shall promptly consult with Engineer concerning the necessity for Owner to retain a qualified expert to evaluate such condition or take corrective action, if any. Promptly after consulting with Engineer, Owner shall take such actions as are necessary to permit Owner to timely obtain required permits and provide Contractor the written notice required by Paragraph 5.06.F. If Contractor or anyone for whom Contractor is responsible created the Hazardous Environmental Condition in question, then Owner may remove and remediate the Hazardous Environmental Condition, and impose a set-off against payments to account for the associated costs.
- F. Contractor shall not resume Work in connection with such Hazardous Environmental Condition or in any affected area until after Owner has obtained any required permits related thereto, and delivered written notice to Contractor either (1) specifying that such condition and any affected area is or has been rendered safe for the resumption of Work, or (2) specifying any special conditions under which such Work may be resumed safely.
- G. If Owner and Contractor cannot agree as to entitlement to or on the amount or extent, if any, of any adjustment in Contract Price or Contract Times, as a result of such Work stoppage, such special conditions under which Work is agreed to be resumed by Contractor, or any costs or expenses incurred in response to the Hazardous Environmental Condition, then within 30 days of Owner's written notice regarding the resumption of Work, Contractor may submit a Change Proposal, or Owner may impose a set-off. Entitlement to any such adjustment is subject to the provisions of Paragraphs 4.05.D, 4.05.E, 11.07, and 11.08.
- H. If, after receipt of such written notice, Contractor does not agree to resume such Work based on a reasonable belief it is unsafe, or does not agree to resume such Work under such special

conditions, then Owner may order the portion of the Work that is in the area affected by such condition to be deleted from the Work, following the contractual change procedures in Article 11. Owner may have such deleted portion of the Work performed by Owner's own forces or others in accordance with Article 8.

- I. To the fullest extent permitted by Laws and Regulations, Owner shall indemnify and hold harmless Contractor, Subcontractors, and Engineer, and the officers, directors, members, partners, employees, agents, consultants, and subcontractors of each and any of them, from and against all claims, costs, losses, and damages (including but not limited to all fees and charges of engineers, architects, attorneys, and other professionals, and all court, arbitration, or other dispute resolution costs) arising out of or relating to a Hazardous Environmental Condition, provided that such Hazardous Environmental Condition (1) was not shown or indicated in the Drawings, Specifications, or other Contract Documents, identified as Technical Data entitled to limited reliance pursuant to Paragraph 5.06.B, or identified in the Contract Documents to be included within the scope of the Work, and (2) was not created by Contractor or by anyone for whom Contractor is responsible. Nothing in this Paragraph 5.06.I obligates Owner to indemnify any individual or entity from and against the consequences of that individual's or entity's own negligence.
- J. To the fullest extent permitted by Laws and Regulations, Contractor shall indemnify and hold harmless Owner and Engineer, and the officers, directors, members, partners, employees, agents, consultants, and subcontractors of each and any of them, from and against all claims, costs, losses, and damages (including but not limited to all fees and charges of engineers, architects, attorneys, and other professionals and all court or arbitration or other dispute resolution costs) arising out of or relating to the failure to control, contain, or remove a Constituent of Concern brought to the Site by Contractor or by anyone for whom Contractor is responsible, or to a Hazardous Environmental Condition created by Contractor or by anyone for whom Contractor is responsible. Nothing in this Paragraph 5.06.J obligates Contractor to indemnify any individual or entity from and against the consequences of that individual's or entity's own negligence.
- K. The provisions of Paragraphs 5.03, 5.04, and 5.05 do not apply to the presence of Constituents of Concern or to a Hazardous Environmental Condition uncovered or revealed at the Site.

## **ARTICLE 6—BONDS AND INSURANCE**

### **6.01 *Performance, Payment, and Other Bonds***

- A. Contractor shall furnish a performance bond and a payment bond, each in an amount at least equal to the Contract Price, as security for the faithful performance and payment of Contractor's obligations under the Contract. These bonds must remain in effect until one year after the date when final payment becomes due or until completion of the correction period specified in Paragraph 15.08, whichever is later, except as provided otherwise by Laws or Regulations, the terms of a prescribed bond form, the Supplementary Conditions, or other provisions of the Contract.
- B. Contractor shall also furnish such other bonds (if any) as are required by the Supplementary Conditions or other provisions of the Contract.
- C. All bonds must be in the form included in the Bidding Documents or otherwise specified by Owner prior to execution of the Contract, except as provided otherwise by Laws or



Regulations, and must be issued and signed by a surety named in “Companies Holding Certificates of Authority as Acceptable Sureties on Federal Bonds and as Acceptable Reinsuring Companies” as published in Department Circular 570 (as amended and supplemented) by the Bureau of the Fiscal Service, U.S. Department of the Treasury. A bond signed by an agent or attorney-in-fact must be accompanied by a certified copy of that individual’s authority to bind the surety. The evidence of authority must show that it is effective on the date the agent or attorney-in-fact signed the accompanying bond.

- D. Contractor shall obtain the required bonds from surety companies that are duly licensed or authorized, in the state or jurisdiction in which the Project is located, to issue bonds in the required amounts.
- E. If the surety on a bond furnished by Contractor is declared bankrupt or becomes insolvent, or the surety ceases to meet the requirements above, then Contractor shall promptly notify Owner and Engineer in writing and shall, within 20 days after the event giving rise to such notification, provide another bond and surety, both of which must comply with the bond and surety requirements above.
- F. If Contractor has failed to obtain a required bond, Owner may exclude the Contractor from the Site and exercise Owner’s termination rights under Article 16.
- G. Upon request to Owner from any Subcontractor, Supplier, or other person or entity claiming to have furnished labor, services, materials, or equipment used in the performance of the Work, Owner shall provide a copy of the payment bond to such person or entity.
- H. Upon request to Contractor from any Subcontractor, Supplier, or other person or entity claiming to have furnished labor, services, materials, or equipment used in the performance of the Work, Contractor shall provide a copy of the payment bond to such person or entity.

#### 6.02 *Insurance—General Provisions*

- A. Owner and Contractor shall obtain and maintain insurance as required in this article and in the Supplementary Conditions.
- B. All insurance required by the Contract to be purchased and maintained by Owner or Contractor shall be obtained from insurance companies that are duly licensed or authorized in the state or jurisdiction in which the Project is located to issue insurance policies for the required limits and coverages. Unless a different standard is indicated in the Supplementary Conditions, all companies that provide insurance policies required under this Contract shall have an A.M. Best rating of A-VII or better.
- C. Alternative forms of insurance coverage, including but not limited to self-insurance and “Occupational Accident and Excess Employer’s Indemnity Policies,” are not sufficient to meet the insurance requirements of this Contract, unless expressly allowed in the Supplementary Conditions.
- D. Contractor shall deliver to Owner, with copies to each additional insured identified in the Contract, certificates of insurance and endorsements establishing that Contractor has obtained and is maintaining the policies and coverages required by the Contract. Upon request by Owner or any other insured, Contractor shall also furnish other evidence of such required insurance, including but not limited to copies of policies, documentation of applicable self-insured retentions (if allowed) and deductibles, full disclosure of all relevant exclusions, and evidence of insurance required to be purchased and maintained by

Subcontractors or Suppliers. In any documentation furnished under this provision, Contractor, Subcontractors, and Suppliers may block out (redact) (1) any confidential premium or pricing information and (2) any wording specific to a project or jurisdiction other than those applicable to this Contract.

- E. Owner shall deliver to Contractor, with copies to each additional insured identified in the Contract, certificates of insurance and endorsements establishing that Owner has obtained and is maintaining the policies and coverages required of Owner by the Contract (if any). Upon request by Contractor or any other insured, Owner shall also provide other evidence of such required insurance (if any), including but not limited to copies of policies, documentation of applicable self-insured retentions (if allowed) and deductibles, and full disclosure of all relevant exclusions. In any documentation furnished under this provision, Owner may block out (redact) (1) any confidential premium or pricing information and (2) any wording specific to a project or jurisdiction other than those relevant to this Contract.
- F. Failure of Owner or Contractor to demand such certificates or other evidence of the other party's full compliance with these insurance requirements, or failure of Owner or Contractor to identify a deficiency in compliance from the evidence provided, will not be construed as a waiver of the other party's obligation to obtain and maintain such insurance.
- G. In addition to the liability insurance required to be provided by Contractor, the Owner, at Owner's option, may purchase and maintain Owner's own liability insurance. Owner's liability policies, if any, operate separately and independently from policies required to be provided by Contractor, and Contractor cannot rely upon Owner's liability policies for any of Contractor's obligations to the Owner, Engineer, or third parties.
- H. Contractor shall require:
  - 1. Subcontractors to purchase and maintain worker's compensation, commercial general liability, and other insurance that is appropriate for their participation in the Project, and to name as additional insureds Owner and Engineer (and any other individuals or entities identified in the Supplementary Conditions as additional insureds on Contractor's liability policies) on each Subcontractor's commercial general liability insurance policy; and
  - 2. Suppliers to purchase and maintain insurance that is appropriate for their participation in the Project.
- I. If either party does not purchase or maintain the insurance required of such party by the Contract, such party shall notify the other party in writing of such failure to purchase prior to the start of the Work, or of such failure to maintain prior to any change in the required coverage.
- J. If Contractor has failed to obtain and maintain required insurance, Contractor's entitlement to enter or remain at the Site will end immediately, and Owner may impose an appropriate set-off against payment for any associated costs (including but not limited to the cost of purchasing necessary insurance coverage), and exercise Owner's termination rights under Article 16.
- K. Without prejudice to any other right or remedy, if a party has failed to obtain required insurance, the other party may elect (but is in no way obligated) to obtain equivalent insurance to protect such other party's interests at the expense of the party who was required to provide such coverage, and the Contract Price will be adjusted accordingly.

- L. Owner does not represent that insurance coverage and limits established in this Contract necessarily will be adequate to protect Contractor or Contractor's interests. Contractor is responsible for determining whether such coverage and limits are adequate to protect its interests, and for obtaining and maintaining any additional insurance that Contractor deems necessary.
- M. The insurance and insurance limits required herein will not be deemed as a limitation on Contractor's liability, or that of its Subcontractors or Suppliers, under the indemnities granted to Owner and other individuals and entities in the Contract or otherwise.
- N. All the policies of insurance required to be purchased and maintained under this Contract will contain a provision or endorsement that the coverage afforded will not be canceled, or renewal refused, until at least 10 days prior written notice has been given to the purchasing policyholder. Within three days of receipt of any such written notice, the purchasing policyholder shall provide a copy of the notice to each other insured and Engineer.

6.03 *Contractor's Insurance*

- A. *Required Insurance:* Contractor shall purchase and maintain Worker's Compensation, Commercial General Liability, and other insurance pursuant to the specific requirements of the Supplementary Conditions.
- B. *General Provisions:* The policies of insurance required by this Paragraph 6.03 as supplemented must:
  - 1. include at least the specific coverages required;
  - 2. be written for not less than the limits provided, or those required by Laws or Regulations, whichever is greater;
  - 3. remain in effect at least until the Work is complete (as set forth in Paragraph 15.06.D), and longer if expressly required elsewhere in this Contract, and at all times thereafter when Contractor may be correcting, removing, or replacing defective Work as a warranty or correction obligation, or otherwise, or returning to the Site to conduct other tasks arising from the Contract;
  - 4. apply with respect to the performance of the Work, whether such performance is by Contractor, any Subcontractor or Supplier, or by anyone directly or indirectly employed by any of them to perform any of the Work, or by anyone for whose acts any of them may be liable; and
  - 5. include all necessary endorsements to support the stated requirements.
- C. *Additional Insureds:* The Contractor's commercial general liability, automobile liability, employer's liability, umbrella or excess, pollution liability, and unmanned aerial vehicle liability policies, if required by this Contract, must:
  - 1. include and list as additional insureds Owner and Engineer, and any individuals or entities identified as additional insureds in the Supplementary Conditions;
  - 2. include coverage for the respective officers, directors, members, partners, employees, and consultants of all such additional insureds;
  - 3. afford primary coverage to these additional insureds for all claims covered thereby (including as applicable those arising from both ongoing and completed operations);

4. not seek contribution from insurance maintained by the additional insured; and
5. as to commercial general liability insurance, apply to additional insureds with respect to liability caused in whole or in part by Contractor's acts or omissions, or the acts and omissions of those working on Contractor's behalf, in the performance of Contractor's operations.

6.04 *Builder's Risk and Other Property Insurance*

- A. *Builder's Risk*: Unless otherwise provided in the Supplementary Conditions, Contractor shall purchase and maintain builder's risk insurance upon the Work on a completed value basis, in the amount of the Work's full insurable replacement cost (subject to such deductible amounts as may be provided in the Supplementary Conditions or required by Laws and Regulations). The specific requirements applicable to the builder's risk insurance are set forth in the Supplementary Conditions.
- B. *Property Insurance for Facilities of Owner Where Work Will Occur*: Owner is responsible for obtaining and maintaining property insurance covering each existing structure, building, or facility in which any part of the Work will occur, or to which any part of the Work will attach or be adjoined. Such property insurance will be written on a special perils (all-risk) form, on a replacement cost basis, providing coverage consistent with that required for the builder's risk insurance, and will be maintained until the Work is complete, as set forth in Paragraph 15.06.D.
- C. *Property Insurance for Substantially Complete Facilities*: Promptly after Substantial Completion, and before actual occupancy or use of the substantially completed Work, Owner will obtain property insurance for such substantially completed Work, and maintain such property insurance at least until the Work is complete, as set forth in Paragraph 15.06.D. Such property insurance will be written on a special perils (all-risk) form, on a replacement cost basis, and provide coverage consistent with that required for the builder's risk insurance. The builder's risk insurance may terminate upon written confirmation of Owner's procurement of such property insurance.
- D. *Partial Occupancy or Use by Owner*: If Owner will occupy or use a portion or portions of the Work prior to Substantial Completion of all the Work, as provided in Paragraph 15.04, then Owner (directly, if it is the purchaser of the builder's risk policy, or through Contractor) will provide advance notice of such occupancy or use to the builder's risk insurer, and obtain an endorsement consenting to the continuation of coverage prior to commencing such partial occupancy or use.
- E. *Insurance of Other Property; Additional Insurance*: If the express insurance provisions of the Contract do not require or address the insurance of a property item or interest, then the entity or individual owning such property item will be responsible for insuring it. If Contractor elects to obtain other special insurance to be included in or supplement the builder's risk or property insurance policies provided under this Paragraph 6.04, it may do so at Contractor's expense.

6.05 *Property Losses; Subrogation*

- A. The builder's risk insurance policy purchased and maintained in accordance with Paragraph 6.04 (or an installation floater policy if authorized by the Supplementary Conditions), will contain provisions to the effect that in the event of payment of any loss or damage the insurer will have no rights of recovery against any insureds thereunder, or against

Engineer or its consultants, or their officers, directors, members, partners, employees, agents, consultants, or subcontractors.

1. Owner and Contractor waive all rights against each other and the respective officers, directors, members, partners, employees, agents, consultants, and subcontractors of each and any of them, for all losses and damages caused by, arising out of, or resulting from any of the perils, risks, or causes of loss covered by such policies and any other property insurance applicable to the Work; and, in addition, waive all such rights against Engineer, its consultants, all individuals or entities identified in the Supplementary Conditions as builder's risk or installation floater insureds, and the officers, directors, members, partners, employees, agents, consultants, and subcontractors of each and any of them, under such policies for losses and damages so caused.
  2. None of the above waivers extends to the rights that any party making such waiver may have to the proceeds of insurance held by Owner or Contractor as trustee or fiduciary, or otherwise payable under any policy so issued.
- B. Any property insurance policy maintained by Owner covering any loss, damage, or consequential loss to Owner's existing structures, buildings, or facilities in which any part of the Work will occur, or to which any part of the Work will attach or adjoin; to adjacent structures, buildings, or facilities of Owner; or to part or all of the completed or substantially completed Work, during partial occupancy or use pursuant to Paragraph 15.04, after Substantial Completion pursuant to Paragraph 15.03, or after final payment pursuant to Paragraph 15.06, will contain provisions to the effect that in the event of payment of any loss or damage the insurer will have no rights of recovery against any insureds thereunder, or against Contractor, Subcontractors, or Engineer, or the officers, directors, members, partners, employees, agents, consultants, or subcontractors of each and any of them, and that the insured is allowed to waive the insurer's rights of subrogation in a written contract executed prior to the loss, damage, or consequential loss.
1. Owner waives all rights against Contractor, Subcontractors, and Engineer, and the officers, directors, members, partners, employees, agents, consultants and subcontractors of each and any of them, for all losses and damages caused by, arising out of, or resulting from fire or any of the perils, risks, or causes of loss covered by such policies.
- C. The waivers in this Paragraph 6.05 include the waiver of rights due to business interruption, loss of use, or other consequential loss extending beyond direct physical loss or damage to Owner's property or the Work caused by, arising out of, or resulting from fire or other insured peril, risk, or cause of loss.
- D. Contractor shall be responsible for assuring that each Subcontract contains provisions whereby the Subcontractor waives all rights against Owner, Contractor, all individuals or entities identified in the Supplementary Conditions as insureds, the Engineer and its consultants, and the officers, directors, members, partners, employees, agents, consultants, and subcontractors of each and any of them, for all losses and damages caused by, arising out of, relating to, or resulting from fire or other peril, risk, or cause of loss covered by builder's risk insurance, installation floater, and any other property insurance applicable to the Work.

6.06 *Receipt and Application of Property Insurance Proceeds*

- A. Any insured loss under the builder's risk and other policies of property insurance required by Paragraph 6.04 will be adjusted and settled with the named insured that purchased the policy. Such named insured shall act as fiduciary for the other insureds, and give notice to such other insureds that adjustment and settlement of a claim is in progress. Any other insured may state its position regarding a claim for insured loss in writing within 15 days after notice of such claim.
- B. Proceeds for such insured losses may be made payable by the insurer either jointly to multiple insureds, or to the named insured that purchased the policy in its own right and as fiduciary for other insureds, subject to the requirements of any applicable mortgage clause. A named insured receiving insurance proceeds under the builder's risk and other policies of insurance required by Paragraph 6.04 shall maintain such proceeds in a segregated account, and distribute such proceeds in accordance with such agreement as the parties in interest may reach, or as otherwise required under the dispute resolution provisions of this Contract or applicable Laws and Regulations.
- C. If no other special agreement is reached, Contractor shall repair or replace the damaged Work, using allocated insurance proceeds.

**ARTICLE 7—CONTRACTOR'S RESPONSIBILITIES**

7.01 *Contractor's Means and Methods of Construction*

- A. Contractor shall be solely responsible for the means, methods, techniques, sequences, and procedures of construction.
- B. If the Contract Documents note, or Contractor determines, that professional engineering or other design services are needed to carry out Contractor's responsibilities for construction means, methods, techniques, sequences, and procedures, or for Site safety, then Contractor shall cause such services to be provided by a properly licensed design professional, at Contractor's expense. Such services are not Owner-delegated professional design services under this Contract, and neither Owner nor Engineer has any responsibility with respect to (1) Contractor's determination of the need for such services, (2) the qualifications or licensing of the design professionals retained or employed by Contractor, (3) the performance of such services, or (4) any errors, omissions, or defects in such services.

7.02 *Supervision and Superintendence*

- A. Contractor shall supervise, inspect, and direct the Work competently and efficiently, devoting such attention thereto and applying such skills and expertise as may be necessary to perform the Work in accordance with the Contract Documents.
- B. At all times during the progress of the Work, Contractor shall assign a competent resident superintendent who will not be replaced without written notice to Owner and Engineer except under extraordinary circumstances.

7.03 *Labor; Working Hours*

- A. Contractor shall provide competent, suitably qualified personnel to survey and lay out the Work and perform construction as required by the Contract Documents. Contractor shall maintain good discipline and order at the Site.

- B. Contractor shall be fully responsible to Owner and Engineer for all acts and omissions of Contractor's employees; of Suppliers and Subcontractors, and their employees; and of any other individuals or entities performing or furnishing any of the Work, just as Contractor is responsible for Contractor's own acts and omissions.
- C. Except as otherwise required for the safety or protection of persons or the Work or property at the Site or adjacent thereto, and except as otherwise stated in the Contract Documents, all Work at the Site will be performed during regular working hours, Monday through Friday. Contractor will not perform Work on a Saturday, Sunday, or any legal holiday. Contractor may perform Work outside regular working hours or on Saturdays, Sundays, or legal holidays only with Owner's written consent, which will not be unreasonably withheld.

7.04 *Services, Materials, and Equipment*

- A. Unless otherwise specified in the Contract Documents, Contractor shall provide and assume full responsibility for all services, materials, equipment, labor, transportation, construction equipment and machinery, tools, appliances, fuel, power, light, heat, telephone, water, sanitary facilities, temporary facilities, and all other facilities and incidentals necessary for the performance, testing, start up, and completion of the Work, whether or not such items are specifically called for in the Contract Documents.
- B. All materials and equipment incorporated into the Work must be new and of good quality, except as otherwise provided in the Contract Documents. All special warranties and guarantees required by the Specifications will expressly run to the benefit of Owner. If required by Engineer, Contractor shall furnish satisfactory evidence (including reports of required tests) as to the source, kind, and quality of materials and equipment.
- C. All materials and equipment must be stored, applied, installed, connected, erected, protected, used, cleaned, and conditioned in accordance with instructions of the applicable Supplier, except as otherwise may be provided in the Contract Documents.

7.05 *"Or Equals"*

- A. *Contractor's Request; Governing Criteria:* Whenever an item of equipment or material is specified or described in the Contract Documents by using the names of one or more proprietary items or specific Suppliers, the Contract Price has been based upon Contractor furnishing such item as specified. The specification or description of such an item is intended to establish the type, function, appearance, and quality required. Unless the specification or description contains or is followed by words reading that no like, equivalent, or "or equal" item is permitted, Contractor may request that Engineer authorize the use of other items of equipment or material, or items from other proposed Suppliers, under the circumstances described below.
  - 1. If Engineer in its sole discretion determines that an item of equipment or material proposed by Contractor is functionally equal to that named and sufficiently similar so that no change in related Work will be required, Engineer will deem it an "or equal" item. For the purposes of this paragraph, a proposed item of equipment or material will be considered functionally equal to an item so named if:
    - a. in the exercise of reasonable judgment Engineer determines that the proposed item:
      - 1) is at least equal in materials of construction, quality, durability, appearance, strength, and design characteristics;



- 2) will reliably perform at least equally well the function and achieve the results imposed by the design concept of the completed Project as a functioning whole;
  - 3) has a proven record of performance and availability of responsive service; and
  - 4) is not objectionable to Owner.
- b. Contractor certifies that, if the proposed item is approved and incorporated into the Work:
- 1) there will be no increase in cost to the Owner or increase in Contract Times; and
  - 2) the item will conform substantially to the detailed requirements of the item named in the Contract Documents.
- B. *Contractor's Expense*: Contractor shall provide all data in support of any proposed "or equal" item at Contractor's expense.
- C. *Engineer's Evaluation and Determination*: Engineer will be allowed a reasonable time to evaluate each "or-equal" request. Engineer may require Contractor to furnish additional data about the proposed "or-equal" item. Engineer will be the sole judge of acceptability. No "or-equal" item will be ordered, furnished, installed, or utilized until Engineer's review is complete and Engineer determines that the proposed item is an "or-equal," which will be evidenced by an approved Shop Drawing or other written communication. Engineer will advise Contractor in writing of any negative determination.
- D. *Effect of Engineer's Determination*: Neither approval nor denial of an "or-equal" request will result in any change in Contract Price. The Engineer's denial of an "or-equal" request will be final and binding, and may not be reversed through an appeal under any provision of the Contract.
- E. *Treatment as a Substitution Request*: If Engineer determines that an item of equipment or material proposed by Contractor does not qualify as an "or-equal" item, Contractor may request that Engineer consider the item a proposed substitute pursuant to Paragraph 7.06.

#### 7.06 Substitutes

- A. *Contractor's Request; Governing Criteria*: Unless the specification or description of an item of equipment or material required to be furnished under the Contract Documents contains or is followed by words reading that no substitution is permitted, Contractor may request that Engineer authorize the use of other items of equipment or material under the circumstances described below. To the extent possible such requests must be made before commencement of related construction at the Site.
1. Contractor shall submit sufficient information as provided below to allow Engineer to determine if the item of material or equipment proposed is functionally equivalent to that named and an acceptable substitute therefor. Engineer will not accept requests for review of proposed substitute items of equipment or material from anyone other than Contractor.
  2. The requirements for review by Engineer will be as set forth in Paragraph 7.06.B, as supplemented by the Specifications, and as Engineer may decide is appropriate under the circumstances.

3. Contractor shall make written application to Engineer for review of a proposed substitute item of equipment or material that Contractor seeks to furnish or use. The application:
  - a. will certify that the proposed substitute item will:
    - 1) perform adequately the functions and achieve the results called for by the general design;
    - 2) be similar in substance to the item specified; and
    - 3) be suited to the same use as the item specified.
  - b. will state:
    - 1) the extent, if any, to which the use of the proposed substitute item will necessitate a change in Contract Times;
    - 2) whether use of the proposed substitute item in the Work will require a change in any of the Contract Documents (or in the provisions of any other direct contract with Owner for other work on the Project) to adapt the design to the proposed substitute item; and
    - 3) whether incorporation or use of the proposed substitute item in connection with the Work is subject to payment of any license fee or royalty.
  - c. will identify:
    - 1) all variations of the proposed substitute item from the item specified; and
    - 2) available engineering, sales, maintenance, repair, and replacement services.
  - d. will contain an itemized estimate of all costs or credits that will result directly or indirectly from use of such substitute item, including but not limited to changes in Contract Price, shared savings, costs of redesign, and claims of other contractors affected by any resulting change.
- B. *Engineer's Evaluation and Determination*: Engineer will be allowed a reasonable time to evaluate each substitute request, and to obtain comments and direction from Owner. Engineer may require Contractor to furnish additional data about the proposed substitute item. Engineer will be the sole judge of acceptability. No substitute will be ordered, furnished, installed, or utilized until Engineer's review is complete and Engineer determines that the proposed item is an acceptable substitute. Engineer's determination will be evidenced by a Field Order or a proposed Change Order accounting for the substitution itself and all related impacts, including changes in Contract Price or Contract Times. Engineer will advise Contractor in writing of any negative determination.
- C. *Special Guarantee*: Owner may require Contractor to furnish at Contractor's expense a special performance guarantee or other surety with respect to any substitute.
- D. *Reimbursement of Engineer's Cost*: Engineer will record Engineer's costs in evaluating a substitute proposed or submitted by Contractor. Whether or not Engineer approves a substitute so proposed or submitted by Contractor, Contractor shall reimburse Owner for the reasonable charges of Engineer for evaluating each such proposed substitute. Contractor shall also reimburse Owner for the reasonable charges of Engineer for making changes in the Contract Documents (or in the provisions of any other direct contract with Owner) resulting from the acceptance of each proposed substitute.

- E. *Contractor's Expense*: Contractor shall provide all data in support of any proposed substitute at Contractor's expense.
- F. *Effect of Engineer's Determination*: If Engineer approves the substitution request, Contractor shall execute the proposed Change Order and proceed with the substitution. The Engineer's denial of a substitution request will be final and binding, and may not be reversed through an appeal under any provision of the Contract. Contractor may challenge the scope of reimbursement costs imposed under Paragraph 7.06.D, by timely submittal of a Change Proposal.

7.07 *Concerning Subcontractors and Suppliers*

- A. Contractor may retain Subcontractors and Suppliers for the performance of parts of the Work. Such Subcontractors and Suppliers must be acceptable to Owner. The Contractor's retention of a Subcontractor or Supplier for the performance of parts of the Work will not relieve Contractor's obligation to Owner to perform and complete the Work in accordance with the Contract Documents.
- B. Contractor shall retain specific Subcontractors and Suppliers for the performance of designated parts of the Work if required by the Contract to do so.
- C. Subsequent to the submittal of Contractor's Bid or final negotiation of the terms of the Contract, Owner may not require Contractor to retain any Subcontractor or Supplier to furnish or perform any of the Work against which Contractor has reasonable objection.
- D. Prior to entry into any binding subcontract or purchase order, Contractor shall submit to Owner the identity of the proposed Subcontractor or Supplier (unless Owner has already deemed such proposed Subcontractor or Supplier acceptable during the bidding process or otherwise). Such proposed Subcontractor or Supplier shall be deemed acceptable to Owner unless Owner raises a substantive, reasonable objection within 5 days.
- E. Owner may require the replacement of any Subcontractor or Supplier. Owner also may require Contractor to retain specific replacements; provided, however, that Owner may not require a replacement to which Contractor has a reasonable objection. If Contractor has submitted the identity of certain Subcontractors or Suppliers for acceptance by Owner, and Owner has accepted it (either in writing or by failing to make written objection thereto), then Owner may subsequently revoke the acceptance of any such Subcontractor or Supplier so identified solely on the basis of substantive, reasonable objection after due investigation. Contractor shall submit an acceptable replacement for the rejected Subcontractor or Supplier.
- F. If Owner requires the replacement of any Subcontractor or Supplier retained by Contractor to perform any part of the Work, then Contractor shall be entitled to an adjustment in Contract Price or Contract Times, with respect to the replacement; and Contractor shall initiate a Change Proposal for such adjustment within 30 days of Owner's requirement of replacement.
- G. No acceptance by Owner of any such Subcontractor or Supplier, whether initially or as a replacement, will constitute a waiver of the right of Owner to the completion of the Work in accordance with the Contract Documents.

- H. On a monthly basis, Contractor shall submit to Engineer a complete list of all Subcontractors and Suppliers having a direct contract with Contractor, and of all other Subcontractors and Suppliers known to Contractor at the time of submittal.
- I. Contractor shall be solely responsible for scheduling and coordinating the work of Subcontractors and Suppliers.
- J. The divisions and sections of the Specifications and the identifications of any Drawings do not control Contractor in dividing the Work among Subcontractors or Suppliers, or in delineating the Work to be performed by any specific trade.
- K. All Work performed for Contractor by a Subcontractor or Supplier must be pursuant to an appropriate contractual agreement that specifically binds the Subcontractor or Supplier to the applicable terms and conditions of the Contract for the benefit of Owner and Engineer.
- L. Owner may furnish to any Subcontractor or Supplier, to the extent practicable, information about amounts paid to Contractor for Work performed for Contractor by the Subcontractor or Supplier.
- M. Contractor shall restrict all Subcontractors and Suppliers from communicating with Engineer or Owner, except through Contractor or in case of an emergency, or as otherwise expressly allowed in this Contract.

7.08 *Patent Fees and Royalties*

- A. Contractor shall pay all license fees and royalties and assume all costs incident to the use in the performance of the Work or the incorporation in the Work of any invention, design, process, product, or device which is the subject of patent rights or copyrights held by others. If an invention, design, process, product, or device is specified in the Contract Documents for use in the performance of the Work and if, to the actual knowledge of Owner or Engineer, its use is subject to patent rights or copyrights calling for the payment of any license fee or royalty to others, the existence of such rights will be disclosed in the Contract Documents.
- B. To the fullest extent permitted by Laws and Regulations, Owner shall indemnify and hold harmless Contractor, and its officers, directors, members, partners, employees, agents, consultants, and subcontractors, from and against all claims, costs, losses, and damages (including but not limited to all fees and charges of engineers, architects, attorneys, and other professionals, and all court or arbitration or other dispute resolution costs) arising out of or relating to any infringement of patent rights or copyrights incident to the use in the performance of the Work or resulting from the incorporation in the Work of any invention, design, process, product, or device specified in the Contract Documents, but not identified as being subject to payment of any license fee or royalty to others required by patent rights or copyrights.
- C. To the fullest extent permitted by Laws and Regulations, Contractor shall indemnify and hold harmless Owner and Engineer, and the officers, directors, members, partners, employees, agents, consultants and subcontractors of each and any of them, from and against all claims, costs, losses, and damages (including but not limited to all fees and charges of engineers, architects, attorneys, and other professionals and all court or arbitration or other dispute resolution costs) arising out of or relating to any infringement of patent rights or copyrights incident to the use in the performance of the Work or resulting from the incorporation in the Work of any invention, design, process, product, or device not specified in the Contract Documents.

#### 7.09 *Permits*

- A. Unless otherwise provided in the Contract Documents, Contractor shall obtain and pay for all construction permits, licenses, and certificates of occupancy. Owner shall assist Contractor, when necessary, in obtaining such permits and licenses. Contractor shall pay all governmental charges and inspection fees necessary for the prosecution of the Work which are applicable at the time of the submission of Contractor's Bid (or when Contractor became bound under a negotiated contract). Owner shall pay all charges of utility owners for connections for providing permanent service to the Work.

#### 7.10 *Taxes*

- A. Contractor shall pay all sales, consumer, use, and other similar taxes required to be paid by Contractor in accordance with the Laws and Regulations of the place of the Project which are applicable during the performance of the Work.

#### 7.11 *Laws and Regulations*

- A. Contractor shall give all notices required by and shall comply with all Laws and Regulations applicable to the performance of the Work. Neither Owner nor Engineer shall be responsible for monitoring Contractor's compliance with any Laws or Regulations.
- B. If Contractor performs any Work or takes any other action knowing or having reason to know that it is contrary to Laws or Regulations, Contractor shall bear all resulting costs and losses, and shall indemnify and hold harmless Owner and Engineer, and the officers, directors, members, partners, employees, agents, consultants, and subcontractors of each and any of them, from and against all claims, costs, losses, and damages (including but not limited to all fees and charges of engineers, architects, attorneys, and other professionals and all court or arbitration or other dispute resolution costs) arising out of or relating to such Work or other action. It is not Contractor's responsibility to make certain that the Work described in the Contract Documents is in accordance with Laws and Regulations, but this does not relieve Contractor of its obligations under Paragraph 3.03.
- C. Owner or Contractor may give written notice to the other party of any changes after the submission of Contractor's Bid (or after the date when Contractor became bound under a negotiated contract) in Laws or Regulations having an effect on the cost or time of performance of the Work, including but not limited to changes in Laws or Regulations having an effect on procuring permits and on sales, use, value-added, consumption, and other similar taxes. If Owner and Contractor are unable to agree on entitlement to or on the amount or extent, if any, of any adjustment in Contract Price or Contract Times resulting from such changes, then within 30 days of such written notice Contractor may submit a Change Proposal, or Owner may initiate a Claim.

#### 7.12 *Record Documents*

- A. Contractor shall maintain in a safe place at the Site one printed record copy of all Drawings, Specifications, Addenda, Change Orders, Work Change Directives, Field Orders, written interpretations and clarifications, and approved Shop Drawings. Contractor shall keep such record documents in good order and annotate them to show changes made during construction. These record documents, together with all approved Samples, will be available to Engineer for reference. Upon completion of the Work, Contractor shall deliver these record documents to Engineer.

7.13 *Safety and Protection*

- A. Contractor shall be solely responsible for initiating, maintaining, and supervising all safety precautions and programs in connection with the Work. Such responsibility does not relieve Subcontractors of their responsibility for the safety of persons or property in the performance of their work, nor for compliance with applicable safety Laws and Regulations.
- B. Contractor shall designate a qualified and experienced safety representative whose duties and responsibilities are the prevention of Work-related accidents and the maintenance and supervision of safety precautions and programs.
- C. Contractor shall take all necessary precautions for the safety of, and shall provide the necessary protection to prevent damage, injury, or loss to:
  - 1. all persons on the Site or who may be affected by the Work;
  - 2. all the Work and materials and equipment to be incorporated therein, whether in storage on or off the Site; and
  - 3. other property at the Site or adjacent thereto, including trees, shrubs, lawns, walks, pavements, roadways, structures, other work in progress, utilities, and Underground Facilities not designated for removal, relocation, or replacement in the course of construction.
- D. All damage, injury, or loss to any property referred to in Paragraph 7.13.C.2 or 7.13.C.3 caused, directly or indirectly, in whole or in part, by Contractor, any Subcontractor, Supplier, or any other individual or entity directly or indirectly employed by any of them to perform any of the Work, or anyone for whose acts any of them may be liable, shall be remedied by Contractor at its expense (except damage or loss attributable to the fault of Drawings or Specifications or to the acts or omissions of Owner or Engineer or anyone employed by any of them, or anyone for whose acts any of them may be liable, and not attributable, directly or indirectly, in whole or in part, to the fault or negligence of Contractor or any Subcontractor, Supplier, or other individual or entity directly or indirectly employed by any of them).
- E. Contractor shall comply with all applicable Laws and Regulations relating to the safety of persons or property, or to the protection of persons or property from damage, injury, or loss; and shall erect and maintain all necessary safeguards for such safety and protection.
- F. Contractor shall notify Owner; the owners of adjacent property; the owners of Underground Facilities and other utilities (if the identity of such owners is known to Contractor); and other contractors and utility owners performing work at or adjacent to the Site, in writing, when Contractor knows that prosecution of the Work may affect them, and shall cooperate with them in the protection, removal, relocation, and replacement of their property or work in progress.
- G. Contractor shall comply with the applicable requirements of Owner's safety programs, if any. Any Owner's safety programs that are applicable to the Work are identified or included in the Supplementary Conditions or Specifications.
- H. Contractor shall inform Owner and Engineer of the specific requirements of Contractor's safety program with which Owner's and Engineer's employees and representatives must comply while at the Site.

- I. Contractor's duties and responsibilities for safety and protection will continue until all the Work is completed, Engineer has issued a written notice to Owner and Contractor in accordance with Paragraph 15.06.C that the Work is acceptable, and Contractor has left the Site (except as otherwise expressly provided in connection with Substantial Completion).
- J. Contractor's duties and responsibilities for safety and protection will resume whenever Contractor or any Subcontractor or Supplier returns to the Site to fulfill warranty or correction obligations, or to conduct other tasks arising from the Contract Documents.

7.14 *Hazard Communication Programs*

- A. Contractor shall be responsible for coordinating any exchange of safety data sheets (formerly known as material safety data sheets) or other hazard communication information required to be made available to or exchanged between or among employers at the Site in accordance with Laws or Regulations.

7.15 *Emergencies*

- A. In emergencies affecting the safety or protection of persons or the Work or property at the Site or adjacent thereto, Contractor is obligated to act to prevent damage, injury, or loss. Contractor shall give Engineer prompt written notice if Contractor believes that any significant changes in the Work or variations from the Contract Documents have been caused by an emergency, or are required as a result of Contractor's response to an emergency. If Engineer determines that a change in the Contract Documents is required because of an emergency or Contractor's response, a Work Change Directive or Change Order will be issued.

7.16 *Submittals*

A. *Shop Drawing and Sample Requirements*

- 1. Before submitting a Shop Drawing or Sample, Contractor shall:
  - a. review and coordinate the Shop Drawing or Sample with other Shop Drawings and Samples and with the requirements of the Work and the Contract Documents;
  - b. determine and verify:
    - 1) all field measurements, quantities, dimensions, specified performance and design criteria, installation requirements, materials, catalog numbers, and similar information with respect to the Submittal;
    - 2) the suitability of all materials and equipment offered with respect to the indicated application, fabrication, shipping, handling, storage, assembly, and installation pertaining to the performance of the Work; and
    - 3) all information relative to Contractor's responsibilities for means, methods, techniques, sequences, and procedures of construction, and safety precautions and programs incident thereto;
  - c. confirm that the Submittal is complete with respect to all related data included in the Submittal.
- 2. Each Shop Drawing or Sample must bear a stamp or specific written certification that Contractor has satisfied Contractor's obligations under the Contract Documents with respect to Contractor's review of that Submittal, and that Contractor approves the Submittal.



3. With each Shop Drawing or Sample, Contractor shall give Engineer specific written notice of any variations that the Submittal may have from the requirements of the Contract Documents. This notice must be set forth in a written communication separate from the Submittal; and, in addition, in the case of a Shop Drawing by a specific notation made on the Shop Drawing itself.
- B. *Submittal Procedures for Shop Drawings and Samples:* Contractor shall label and submit Shop Drawings and Samples to Engineer for review and approval in accordance with the accepted Schedule of Submittals.
1. *Shop Drawings*
    - a. Contractor shall submit the number of copies required in the Specifications.
    - b. Data shown on the Shop Drawings must be complete with respect to quantities, dimensions, specified performance and design criteria, materials, and similar data to show Engineer the services, materials, and equipment Contractor proposes to provide, and to enable Engineer to review the information for the limited purposes required by Paragraph 7.16.C.
  2. *Samples*
    - a. Contractor shall submit the number of Samples required in the Specifications.
    - b. Contractor shall clearly identify each Sample as to material, Supplier, pertinent data such as catalog numbers, the use for which intended and other data as Engineer may require to enable Engineer to review the Submittal for the limited purposes required by Paragraph 7.16.C.
  3. Where a Shop Drawing or Sample is required by the Contract Documents or the Schedule of Submittals, any related Work performed prior to Engineer's review and approval of the pertinent submittal will be at the sole expense and responsibility of Contractor.
- C. *Engineer's Review of Shop Drawings and Samples*
1. Engineer will provide timely review of Shop Drawings and Samples in accordance with the accepted Schedule of Submittals. Engineer's review and approval will be only to determine if the items covered by the Submittals will, after installation or incorporation in the Work, comply with the requirements of the Contract Documents, and be compatible with the design concept of the completed Project as a functioning whole as indicated by the Contract Documents.
  2. Engineer's review and approval will not extend to means, methods, techniques, sequences, or procedures of construction, or to safety precautions or programs incident thereto.
  3. Engineer's review and approval of a separate item as such will not indicate approval of the assembly in which the item functions.
  4. Engineer's review and approval of a Shop Drawing or Sample will not relieve Contractor from responsibility for any variation from the requirements of the Contract Documents unless Contractor has complied with the requirements of Paragraph 7.16.A.3 and Engineer has given written approval of each such variation by specific written notation thereof incorporated in or accompanying the Shop Drawing or Sample. Engineer will

document any such approved variation from the requirements of the Contract Documents in a Field Order or other appropriate Contract modification.

5. Engineer's review and approval of a Shop Drawing or Sample will not relieve Contractor from responsibility for complying with the requirements of Paragraphs 7.16.A and B.
  6. Engineer's review and approval of a Shop Drawing or Sample, or of a variation from the requirements of the Contract Documents, will not, under any circumstances, change the Contract Times or Contract Price, unless such changes are included in a Change Order.
  7. Neither Engineer's receipt, review, acceptance, or approval of a Shop Drawing or Sample will result in such item becoming a Contract Document.
  8. Contractor shall perform the Work in compliance with the requirements and commitments set forth in approved Shop Drawings and Samples, subject to the provisions of Paragraph 7.16.C.4.
- D. *Resubmittal Procedures for Shop Drawings and Samples*
1. Contractor shall make corrections required by Engineer and shall return the required number of corrected copies of Shop Drawings and submit, as required, new Samples for review and approval. Contractor shall direct specific attention in writing to revisions other than the corrections called for by Engineer on previous Submittals.
  2. Contractor shall furnish required Shop Drawing and Sample submittals with sufficient information and accuracy to obtain required approval of an item with no more than two resubmittals. Engineer will record Engineer's time for reviewing a third or subsequent resubmittal of a Shop Drawing or Sample, and Contractor shall be responsible for Engineer's charges to Owner for such time. Owner may impose a set-off against payments due Contractor to secure reimbursement for such charges.
  3. If Contractor requests a change of a previously approved Shop Drawing or Sample, Contractor shall be responsible for Engineer's charges to Owner for its review time, and Owner may impose a set-off against payments due Contractor to secure reimbursement for such charges, unless the need for such change is beyond the control of Contractor.
- E. *Submittals Other than Shop Drawings, Samples, and Owner-Delegated Designs*
1. The following provisions apply to all Submittals other than Shop Drawings, Samples, and Owner-delegated designs:
    - a. Contractor shall submit all such Submittals to the Engineer in accordance with the Schedule of Submittals and pursuant to the applicable terms of the Contract Documents.
    - b. Engineer will provide timely review of all such Submittals in accordance with the Schedule of Submittals and return such Submittals with a notation of either Accepted or Not Accepted. Any such Submittal that is not returned within the time established in the Schedule of Submittals will be deemed accepted.
    - c. Engineer's review will be only to determine if the Submittal is acceptable under the requirements of the Contract Documents as to general form and content of the Submittal.

- d. If any such Submittal is not accepted, Contractor shall confer with Engineer regarding the reason for the non-acceptance, and resubmit an acceptable document.
  2. Procedures for the submittal and acceptance of the Progress Schedule, the Schedule of Submittals, and the Schedule of Values are set forth in Paragraphs 2.03, 2.04, and 2.05.
  - F. Owner-delegated Designs: Submittals pursuant to Owner-delegated designs are governed by the provisions of Paragraph 7.19.
- 7.17 *Contractor's General Warranty and Guarantee*
- A. Contractor warrants and guarantees to Owner that all Work will be in accordance with the Contract Documents and will not be defective. Engineer is entitled to rely on Contractor's warranty and guarantee.
  - B. Owner's rights under this warranty and guarantee are in addition to, and are not limited by, Owner's rights under the correction period provisions of Paragraph 15.08. The time in which Owner may enforce its warranty and guarantee rights under this Paragraph 7.17 is limited only by applicable Laws and Regulations restricting actions to enforce such rights; provided, however, that after the end of the correction period under Paragraph 15.08:
    1. Owner shall give Contractor written notice of any defective Work within 60 days of the discovery that such Work is defective; and
    2. Such notice will be deemed the start of an event giving rise to a Claim under Paragraph 12.01.B, such that any related Claim must be brought within 30 days of the notice.
  - C. Contractor's warranty and guarantee hereunder excludes defects or damage caused by:
    1. abuse, or improper modification, maintenance, or operation, by persons other than Contractor, Subcontractors, Suppliers, or any other individual or entity for whom Contractor is responsible; or
    2. normal wear and tear under normal usage.
  - D. Contractor's obligation to perform and complete the Work in accordance with the Contract Documents is absolute. None of the following will constitute an acceptance of Work that is not in accordance with the Contract Documents, a release of Contractor's obligation to perform the Work in accordance with the Contract Documents, or a release of Owner's warranty and guarantee rights under this Paragraph 7.17:
    1. Observations by Engineer;
    2. Recommendation by Engineer or payment by Owner of any progress or final payment;
    3. The issuance of a certificate of Substantial Completion by Engineer or any payment related thereto by Owner;
    4. Use or occupancy of the Work or any part thereof by Owner;
    5. Any review and approval of a Shop Drawing or Sample submittal;
    6. The issuance of a notice of acceptability by Engineer;
    7. The end of the correction period established in Paragraph 15.08;
    8. Any inspection, test, or approval by others; or

9. Any correction of defective Work by Owner.
- E. If the Contract requires the Contractor to accept the assignment of a contract entered into by Owner, then the specific warranties, guarantees, and correction obligations contained in the assigned contract will govern with respect to Contractor's performance obligations to Owner for the Work described in the assigned contract.

7.18 *Indemnification*

- A. To the fullest extent permitted by Laws and Regulations, and in addition to any other obligations of Contractor under the Contract or otherwise, Contractor shall indemnify and hold harmless Owner and Engineer, and the officers, directors, members, partners, employees, agents, consultants and subcontractors of each and any of them, from losses, damages, costs, and judgments (including but not limited to all fees and charges of engineers, architects, attorneys, and other professionals, and all court or arbitration or other dispute resolution costs) arising from third-party claims or actions relating to or resulting from the performance or furnishing of the Work, provided that any such claim, action, loss, cost, judgment or damage is attributable to bodily injury, sickness, disease, or death, or to damage to or destruction of tangible property (other than the Work itself), including the loss of use resulting therefrom, but only to the extent caused by any negligent act or omission of Contractor, any Subcontractor, any Supplier, or any individual or entity directly or indirectly employed by any of them to perform any of the Work, or anyone for whose acts any of them may be liable.
- B. In any and all claims against Owner or Engineer, or any of their officers, directors, members, partners, employees, agents, consultants, or subcontractors, by any employee (or the survivor or personal representative of such employee) of Contractor, any Subcontractor, any Supplier, or any individual or entity directly or indirectly employed by any of them to perform any of the Work, or anyone for whose acts any of them may be liable, the indemnification obligation under Paragraph 7.18.A will not be limited in any way by any limitation on the amount or type of damages, compensation, or benefits payable by or for Contractor or any such Subcontractor, Supplier, or other individual or entity under workers' compensation acts, disability benefit acts, or other employee benefit acts.

7.19 *Delegation of Professional Design Services*

- A. Owner may require Contractor to provide professional design services for a portion of the Work by express delegation in the Contract Documents. Such delegation will specify the performance and design criteria that such services must satisfy, and the Submittals that Contractor must furnish to Engineer with respect to the Owner-delegated design.
- B. Contractor shall cause such Owner-delegated professional design services to be provided pursuant to the professional standard of care by a properly licensed design professional, whose signature and seal must appear on all drawings, calculations, specifications, certifications, and Submittals prepared by such design professional. Such design professional must issue all certifications of design required by Laws and Regulations.
- C. If a Shop Drawing or other Submittal related to the Owner-delegated design is prepared by Contractor, a Subcontractor, or others for submittal to Engineer, then such Shop Drawing or other Submittal must bear the written approval of Contractor's design professional when submitted by Contractor to Engineer.

- D. Owner and Engineer shall be entitled to rely upon the adequacy, accuracy, and completeness of the services, certifications, and approvals performed or provided by the design professionals retained or employed by Contractor under an Owner-delegated design, subject to the professional standard of care and the performance and design criteria stated in the Contract Documents.
- E. Pursuant to this Paragraph 7.19, Engineer's review, approval, and other determinations regarding design drawings, calculations, specifications, certifications, and other Submittals furnished by Contractor pursuant to an Owner-delegated design will be only for the following limited purposes:
  - 1. Checking for conformance with the requirements of this Paragraph 7.19;
  - 2. Confirming that Contractor (through its design professionals) has used the performance and design criteria specified in the Contract Documents; and
  - 3. Establishing that the design furnished by Contractor is consistent with the design concept expressed in the Contract Documents.
- F. Contractor shall not be responsible for the adequacy of performance or design criteria specified by Owner or Engineer.
- G. Contractor is not required to provide professional services in violation of applicable Laws and Regulations.

## **ARTICLE 8—OTHER WORK AT THE SITE**

### **8.01 *Other Work***

- A. In addition to and apart from the Work under the Contract Documents, the Owner may perform other work at or adjacent to the Site. Such other work may be performed by Owner's employees, or through contracts between the Owner and third parties. Owner may also arrange to have third-party utility owners perform work on their utilities and facilities at or adjacent to the Site.
- B. If Owner performs other work at or adjacent to the Site with Owner's employees, or through contracts for such other work, then Owner shall give Contractor written notice thereof prior to starting any such other work. If Owner has advance information regarding the start of any third-party utility work that Owner has arranged to take place at or adjacent to the Site, Owner shall provide such information to Contractor.
- C. Contractor shall afford proper and safe access to the Site to each contractor that performs such other work, each utility owner performing other work, and Owner, if Owner is performing other work with Owner's employees, and provide a reasonable opportunity for the introduction and storage of materials and equipment and the execution of such other work.
- D. Contractor shall do all cutting, fitting, and patching of the Work that may be required to properly connect or otherwise make its several parts come together and properly integrate with such other work. Contractor shall not endanger any work of others by cutting, excavating, or otherwise altering such work; provided, however, that Contractor may cut or alter others' work with the written consent of Engineer and the others whose work will be affected.

- E. If the proper execution or results of any part of Contractor's Work depends upon work performed by others, Contractor shall inspect such other work and promptly report to Engineer in writing any delays, defects, or deficiencies in such other work that render it unavailable or unsuitable for the proper execution and results of Contractor's Work. Contractor's failure to so report will constitute an acceptance of such other work as fit and proper for integration with Contractor's Work except for latent defects and deficiencies in such other work.
- F. The provisions of this article are not applicable to work that is performed by third-party utilities or other third-party entities without a contract with Owner, or that is performed without having been arranged by Owner. If such work occurs, then any related delay, disruption, or interference incurred by Contractor is governed by the provisions of Paragraph 4.05.C.3.

#### 8.02 *Coordination*

- A. If Owner intends to contract with others for the performance of other work at or adjacent to the Site, to perform other work at or adjacent to the Site with Owner's employees, or to arrange to have utility owners perform work at or adjacent to the Site, the following will be set forth in the Supplementary Conditions or provided to Contractor prior to the start of any such other work:
  - 1. The identity of the individual or entity that will have authority and responsibility for coordination of the activities among the various contractors;
  - 2. An itemization of the specific matters to be covered by such authority and responsibility; and
  - 3. The extent of such authority and responsibilities.
- B. Unless otherwise provided in the Supplementary Conditions, Owner shall have sole authority and responsibility for such coordination.

#### 8.03 *Legal Relationships*

- A. If, in the course of performing other work for Owner at or adjacent to the Site, the Owner's employees, any other contractor working for Owner, or any utility owner that Owner has arranged to perform work, causes damage to the Work or to the property of Contractor or its Subcontractors, or delays, disrupts, interferes with, or increases the scope or cost of the performance of the Work, through actions or inaction, then Contractor shall be entitled to an equitable adjustment in the Contract Price or the Contract Times. Contractor must submit any Change Proposal seeking an equitable adjustment in the Contract Price or the Contract Times under this paragraph within 30 days of the damaging, delaying, disrupting, or interfering event. The entitlement to, and extent of, any such equitable adjustment will take into account information (if any) regarding such other work that was provided to Contractor in the Contract Documents prior to the submittal of the Bid or the final negotiation of the terms of the Contract, and any remedies available to Contractor under Laws or Regulations concerning utility action or inaction. When applicable, any such equitable adjustment in Contract Price will be conditioned on Contractor assigning to Owner all Contractor's rights against such other contractor or utility owner with respect to the damage, delay, disruption, or interference that is the subject of the adjustment. Contractor's entitlement to an adjustment of the Contract Times or Contract Price is subject to the provisions of Paragraphs 4.05.D and 4.05.E.

- B. Contractor shall take reasonable and customary measures to avoid damaging, delaying, disrupting, or interfering with the work of Owner, any other contractor, or any utility owner performing other work at or adjacent to the Site.
  - 1. If Contractor fails to take such measures and as a result damages, delays, disrupts, or interferes with the work of any such other contractor or utility owner, then Owner may impose a set-off against payments due Contractor, and assign to such other contractor or utility owner the Owner's contractual rights against Contractor with respect to the breach of the obligations set forth in this Paragraph 8.03.B.
  - 2. When Owner is performing other work at or adjacent to the Site with Owner's employees, Contractor shall be liable to Owner for damage to such other work, and for the reasonable direct delay, disruption, and interference costs incurred by Owner as a result of Contractor's failure to take reasonable and customary measures with respect to Owner's other work. In response to such damage, delay, disruption, or interference, Owner may impose a set-off against payments due Contractor.
- C. If Contractor damages, delays, disrupts, or interferes with the work of any other contractor, or any utility owner performing other work at or adjacent to the Site, through Contractor's failure to take reasonable and customary measures to avoid such impacts, or if any claim arising out of Contractor's actions, inactions, or negligence in performance of the Work at or adjacent to the Site is made by any such other contractor or utility owner against Contractor, Owner, or Engineer, then Contractor shall (1) promptly attempt to settle the claim as to all parties through negotiations with such other contractor or utility owner, or otherwise resolve the claim by arbitration or other dispute resolution proceeding or at law, and (2) indemnify and hold harmless Owner and Engineer, and the officers, directors, members, partners, employees, agents, consultants and subcontractors of each and any of them from and against any such claims, and against all costs, losses, and damages (including but not limited to all fees and charges of engineers, architects, attorneys, and other professionals and all court or arbitration or other dispute resolution costs) arising out of or relating to such damage, delay, disruption, or interference.

## **ARTICLE 9—OWNER'S RESPONSIBILITIES**

### **9.01 *Communications to Contractor***

- A. Except as otherwise provided in these General Conditions, Owner shall issue all communications to Contractor through Engineer.

### **9.02 *Replacement of Engineer***

- A. Owner may at its discretion appoint an engineer to replace Engineer, provided Contractor makes no reasonable objection to the replacement engineer. The replacement engineer's status under the Contract Documents will be that of the former Engineer.

### **9.03 *Furnish Data***

- A. Owner shall promptly furnish the data required of Owner under the Contract Documents.

### **9.04 *Pay When Due***

- A. Owner shall make payments to Contractor when they are due as provided in the Agreement.



- 9.05 *Lands and Easements; Reports, Tests, and Drawings*
- A. Owner's duties with respect to providing lands and easements are set forth in Paragraph 5.01.
  - B. Owner's duties with respect to providing engineering surveys to establish reference points are set forth in Paragraph 4.03.
  - C. Article 5 refers to Owner's identifying and making available to Contractor copies of reports of explorations and tests of conditions at the Site, and drawings of physical conditions relating to existing surface or subsurface structures at the Site.
- 9.06 *Insurance*
- A. Owner's responsibilities, if any, with respect to purchasing and maintaining liability and property insurance are set forth in Article 6.
- 9.07 *Change Orders*
- A. Owner's responsibilities with respect to Change Orders are set forth in Article 11.
- 9.08 *Inspections, Tests, and Approvals*
- A. Owner's responsibility with respect to certain inspections, tests, and approvals is set forth in Paragraph 14.02.B.
- 9.09 *Limitations on Owner's Responsibilities*
- A. The Owner shall not supervise, direct, or have control or authority over, nor be responsible for, Contractor's means, methods, techniques, sequences, or procedures of construction, or the safety precautions and programs incident thereto, or for any failure of Contractor to comply with Laws and Regulations applicable to the performance of the Work. Owner will not be responsible for Contractor's failure to perform the Work in accordance with the Contract Documents.
- 9.10 *Undisclosed Hazardous Environmental Condition*
- A. Owner's responsibility in respect to an undisclosed Hazardous Environmental Condition is set forth in Paragraph 5.06.
- 9.11 *Evidence of Financial Arrangements*
- A. Upon request of Contractor, Owner shall furnish Contractor reasonable evidence that financial arrangements have been made to satisfy Owner's obligations under the Contract (including obligations under proposed changes in the Work).
- 9.12 *Safety Programs*
- A. While at the Site, Owner's employees and representatives shall comply with the specific applicable requirements of Contractor's safety programs of which Owner has been informed.
  - B. Owner shall furnish copies of any applicable Owner safety programs to Contractor.

## ARTICLE 10—ENGINEER’S STATUS DURING CONSTRUCTION

### 10.01 *Owner’s Representative*

- A. Engineer will be Owner’s representative during the construction period. The duties and responsibilities and the limitations of authority of Engineer as Owner’s representative during construction are set forth in the Contract.

### 10.02 *Visits to Site*

- A. Engineer will make visits to the Site at intervals appropriate to the various stages of construction as Engineer deems necessary in order to observe, as an experienced and qualified design professional, the progress that has been made and the quality of the various aspects of Contractor’s executed Work. Based on information obtained during such visits and observations, Engineer, for the benefit of Owner, will determine, in general, if the Work is proceeding in accordance with the Contract Documents. Engineer will not be required to make exhaustive or continuous inspections on the Site to check the quality or quantity of the Work. Engineer’s efforts will be directed toward providing for Owner a greater degree of confidence that the completed Work will conform generally to the Contract Documents. On the basis of such visits and observations, Engineer will keep Owner informed of the progress of the Work and will endeavor to guard Owner against defective Work.
- B. Engineer’s visits and observations are subject to all the limitations on Engineer’s authority and responsibility set forth in Paragraph 10.07. Particularly, but without limitation, during or as a result of Engineer’s visits or observations of Contractor’s Work, Engineer will not supervise, direct, control, or have authority over or be responsible for Contractor’s means, methods, techniques, sequences, or procedures of construction, or the safety precautions and programs incident thereto, or for any failure of Contractor to comply with Laws and Regulations applicable to the performance of the Work.

### 10.03 *Resident Project Representative*

- A. If Owner and Engineer have agreed that Engineer will furnish a Resident Project Representative to represent Engineer at the Site and assist Engineer in observing the progress and quality of the Work, then the authority and responsibilities of any such Resident Project Representative will be as provided in the Supplementary Conditions, and limitations on the responsibilities thereof will be as provided in the Supplementary Conditions and in Paragraph 10.07.
- B. If Owner designates an individual or entity who is not Engineer’s consultant, agent, or employee to represent Owner at the Site, then the responsibilities and authority of such individual or entity will be as provided in the Supplementary Conditions.

### 10.04 *Engineer’s Authority*

- A. Engineer has the authority to reject Work in accordance with Article 14.
- B. Engineer’s authority as to Submittals is set forth in Paragraph 7.16.
- C. Engineer’s authority as to design drawings, calculations, specifications, certifications and other Submittals from Contractor in response to Owner’s delegation (if any) to Contractor of professional design services, is set forth in Paragraph 7.19.
- D. Engineer’s authority as to changes in the Work is set forth in Article 11.

E. Engineer's authority as to Applications for Payment is set forth in Article 15.

10.05 *Determinations for Unit Price Work*

A. Engineer will determine the actual quantities and classifications of Unit Price Work performed by Contractor as set forth in Paragraph 13.03.

10.06 *Decisions on Requirements of Contract Documents and Acceptability of Work*

A. Engineer will render decisions regarding the requirements of the Contract Documents, and judge the acceptability of the Work, pursuant to the specific procedures set forth herein for initial interpretations, Change Proposals, and acceptance of the Work. In rendering such decisions and judgments, Engineer will not show partiality to Owner or Contractor, and will not be liable to Owner, Contractor, or others in connection with any proceedings, interpretations, decisions, or judgments conducted or rendered in good faith.

10.07 *Limitations on Engineer's Authority and Responsibilities*

- A. Neither Engineer's authority or responsibility under this Article 10 or under any other provision of the Contract, nor any decision made by Engineer in good faith either to exercise or not exercise such authority or responsibility or the undertaking, exercise, or performance of any authority or responsibility by Engineer, will create, impose, or give rise to any duty in contract, tort, or otherwise owed by Engineer to Contractor, any Subcontractor, any Supplier, any other individual or entity, or to any surety for or employee or agent of any of them.
- B. Engineer will not supervise, direct, control, or have authority over or be responsible for Contractor's means, methods, techniques, sequences, or procedures of construction, or the safety precautions and programs incident thereto, or for any failure of Contractor to comply with Laws and Regulations applicable to the performance of the Work. Engineer will not be responsible for Contractor's failure to perform the Work in accordance with the Contract Documents.
- C. Engineer will not be responsible for the acts or omissions of Contractor or of any Subcontractor, any Supplier, or of any other individual or entity performing any of the Work.
- D. Engineer's review of the final Application for Payment and accompanying documentation, and all maintenance and operating instructions, schedules, guarantees, bonds, certificates of inspection, tests and approvals, and other documentation required to be delivered by Contractor under Paragraph 15.06.A, will only be to determine generally that their content complies with the requirements of, and in the case of certificates of inspections, tests, and approvals, that the results certified indicate compliance with the Contract Documents.
- E. The limitations upon authority and responsibility set forth in this Paragraph 10.07 also apply to the Resident Project Representative, if any.

10.08 *Compliance with Safety Program*

A. While at the Site, Engineer's employees and representatives will comply with the specific applicable requirements of Owner's and Contractor's safety programs of which Engineer has been informed.

## ARTICLE 11—CHANGES TO THE CONTRACT

### 11.01 *Amending and Supplementing the Contract*

- A. The Contract may be amended or supplemented by a Change Order, a Work Change Directive, or a Field Order.
- B. If an amendment or supplement to the Contract includes a change in the Contract Price or the Contract Times, such amendment or supplement must be set forth in a Change Order.
- C. All changes to the Contract that involve (1) the performance or acceptability of the Work, (2) the design (as set forth in the Drawings, Specifications, or otherwise), or (3) other engineering or technical matters, must be supported by Engineer's recommendation. Owner and Contractor may amend other terms and conditions of the Contract without the recommendation of the Engineer.

### 11.02 *Change Orders*

- A. Owner and Contractor shall execute appropriate Change Orders covering:
  1. Changes in Contract Price or Contract Times which are agreed to by the parties, including any undisputed sum or amount of time for Work actually performed in accordance with a Work Change Directive;
  2. Changes in Contract Price resulting from an Owner set-off, unless Contractor has duly contested such set-off;
  3. Changes in the Work which are: (a) ordered by Owner pursuant to Paragraph 11.05, (b) required because of Owner's acceptance of defective Work under Paragraph 14.04 or Owner's correction of defective Work under Paragraph 14.07, or (c) agreed to by the parties, subject to the need for Engineer's recommendation if the change in the Work involves the design (as set forth in the Drawings, Specifications, or otherwise) or other engineering or technical matters; and
  4. Changes that embody the substance of any final and binding results under: Paragraph 11.03.B, resolving the impact of a Work Change Directive; Paragraph 11.09, concerning Change Proposals; Article 12, Claims; Paragraph 13.02.D, final adjustments resulting from allowances; Paragraph 13.03.D, final adjustments relating to determination of quantities for Unit Price Work; and similar provisions.
- B. If Owner or Contractor refuses to execute a Change Order that is required to be executed under the terms of Paragraph 11.02.A, it will be deemed to be of full force and effect, as if fully executed.

### 11.03 *Work Change Directives*

- A. A Work Change Directive will not change the Contract Price or the Contract Times but is evidence that the parties expect that the modification ordered or documented by a Work Change Directive will be incorporated in a subsequently issued Change Order, following negotiations by the parties as to the Work Change Directive's effect, if any, on the Contract Price and Contract Times; or, if negotiations are unsuccessful, by a determination under the terms of the Contract Documents governing adjustments, expressly including Paragraph 11.07 regarding change of Contract Price.

- B. If Owner has issued a Work Change Directive and:
  - 1. Contractor believes that an adjustment in Contract Times or Contract Price is necessary, then Contractor shall submit any Change Proposal seeking such an adjustment no later than 30 days after the completion of the Work set out in the Work Change Directive.
  - 2. Owner believes that an adjustment in Contract Times or Contract Price is necessary, then Owner shall submit any Claim seeking such an adjustment no later than 60 days after issuance of the Work Change Directive.

11.04 *Field Orders*

- A. Engineer may authorize minor changes in the Work if the changes do not involve an adjustment in the Contract Price or the Contract Times and are compatible with the design concept of the completed Project as a functioning whole as indicated by the Contract Documents. Such changes will be accomplished by a Field Order and will be binding on Owner and also on Contractor, which shall perform the Work involved promptly.
- B. If Contractor believes that a Field Order justifies an adjustment in the Contract Price or Contract Times, then before proceeding with the Work at issue, Contractor shall submit a Change Proposal as provided herein.

11.05 *Owner-Authorized Changes in the Work*

- A. Without invalidating the Contract and without notice to any surety, Owner may, at any time or from time to time, order additions, deletions, or revisions in the Work. Changes involving the design (as set forth in the Drawings, Specifications, or otherwise) or other engineering or technical matters will be supported by Engineer's recommendation.
- B. Such changes in the Work may be accomplished by a Change Order, if Owner and Contractor have agreed as to the effect, if any, of the changes on Contract Times or Contract Price; or by a Work Change Directive. Upon receipt of any such document, Contractor shall promptly proceed with the Work involved; or, in the case of a deletion in the Work, promptly cease construction activities with respect to such deleted Work. Added or revised Work must be performed under the applicable conditions of the Contract Documents.
- C. Nothing in this Paragraph 11.05 obligates Contractor to undertake work that Contractor reasonably concludes cannot be performed in a manner consistent with Contractor's safety obligations under the Contract Documents or Laws and Regulations.

11.06 *Unauthorized Changes in the Work*

- A. Contractor shall not be entitled to an increase in the Contract Price or an extension of the Contract Times with respect to any work performed that is not required by the Contract Documents, as amended, modified, or supplemented, except in the case of an emergency as provided in Paragraph 7.15 or in the case of uncovering Work as provided in Paragraph 14.05.C.2.

11.07 *Change of Contract Price*

- A. The Contract Price may only be changed by a Change Order. Any Change Proposal for an adjustment in the Contract Price must comply with the provisions of Paragraph 11.09. Any Claim for an adjustment of Contract Price must comply with the provisions of Article 12.
- B. An adjustment in the Contract Price will be determined as follows:

1. Where the Work involved is covered by unit prices contained in the Contract Documents, then by application of such unit prices to the quantities of the items involved (subject to the provisions of Paragraph 13.03);
  2. Where the Work involved is not covered by unit prices contained in the Contract Documents, then by a mutually agreed lump sum (which may include an allowance for overhead and profit not necessarily in accordance with Paragraph 11.07.C.2); or
  3. Where the Work involved is not covered by unit prices contained in the Contract Documents and the parties do not reach mutual agreement to a lump sum, then on the basis of the Cost of the Work (determined as provided in Paragraph 13.01) plus a Contractor's fee for overhead and profit (determined as provided in Paragraph 11.07.C).
- C. *Contractor's Fee*: When applicable, the Contractor's fee for overhead and profit will be determined as follows:
1. A mutually acceptable fixed fee; or
  2. If a fixed fee is not agreed upon, then a fee based on the following percentages of the various portions of the Cost of the Work:
    - a. For costs incurred under Paragraphs 13.01.B.1 and 13.01.B.2, the Contractor's fee will be 15 percent;
    - b. For costs incurred under Paragraph 13.01.B.3, the Contractor's fee will be 5 percent;
    - c. Where one or more tiers of subcontracts are on the basis of Cost of the Work plus a fee and no fixed fee is agreed upon, the intent of Paragraphs 11.07.C.2.a and 11.07.C.2.b is that the Contractor's fee will be based on: (1) a fee of 15 percent of the costs incurred under Paragraphs 13.01.B.1 and 13.01.B.2 by the Subcontractor that actually performs the Work, at whatever tier, and (2) with respect to Contractor itself and to any Subcontractors of a tier higher than that of the Subcontractor that actually performs the Work, a fee of 5 percent of the amount (fee plus underlying costs incurred) attributable to the next lower tier Subcontractor; provided, however, that for any such subcontracted Work the maximum total fee to be paid by Owner will be no greater than 27 percent of the costs incurred by the Subcontractor that actually performs the Work;
    - d. No fee will be payable on the basis of costs itemized under Paragraphs 13.01.B.4, 13.01.B.5, and 13.01.C;
    - e. The amount of credit to be allowed by Contractor to Owner for any change which results in a net decrease in Cost of the Work will be the amount of the actual net decrease in Cost of the Work and a deduction of an additional amount equal to 5 percent of such actual net decrease in Cost of the Work; and
    - f. When both additions and credits are involved in any one change or Change Proposal, the adjustment in Contractor's fee will be computed by determining the sum of the costs in each of the cost categories in Paragraph 13.01.B (specifically, payroll costs, Paragraph 13.01.B.1; incorporated materials and equipment costs, Paragraph 13.01.B.2; Subcontract costs, Paragraph 13.01.B.3; special consultants costs, Paragraph 13.01.B.4; and other costs, Paragraph 13.01.B.5) and applying to each such cost category sum the appropriate fee from Paragraphs 11.07.C.2.a through 11.07.C.2.e, inclusive.

11.08 *Change of Contract Times*

- A. The Contract Times may only be changed by a Change Order. Any Change Proposal for an adjustment in the Contract Times must comply with the provisions of Paragraph 11.09. Any Claim for an adjustment in the Contract Times must comply with the provisions of Article 12.
- B. Delay, disruption, and interference in the Work, and any related changes in Contract Times, are addressed in and governed by Paragraph 4.05.

11.09 *Change Proposals*

A. *Purpose and Content:* Contractor shall submit a Change Proposal to Engineer to request an adjustment in the Contract Times or Contract Price; contest an initial decision by Engineer concerning the requirements of the Contract Documents or relating to the acceptability of the Work under the Contract Documents; challenge a set-off against payment due; or seek other relief under the Contract. The Change Proposal will specify any proposed change in Contract Times or Contract Price, or other proposed relief, and explain the reason for the proposed change, with citations to any governing or applicable provisions of the Contract Documents. Each Change Proposal will address only one issue, or a set of closely related issues.

B. *Change Proposal Procedures*

1. *Submittal:* Contractor shall submit each Change Proposal to Engineer within 30 days after the start of the event giving rise thereto, or after such initial decision.
2. *Supporting Data:* The Contractor shall submit supporting data, including the proposed change in Contract Price or Contract Time (if any), to the Engineer and Owner within 15 days after the submittal of the Change Proposal.
  - a. Change Proposals based on or related to delay, interruption, or interference must comply with the provisions of Paragraphs 4.05.D and 4.05.E.
  - b. Change proposals related to a change of Contract Price must include full and detailed accounts of materials incorporated into the Work and labor and equipment used for the subject Work.

The supporting data must be accompanied by a written statement that the supporting data are accurate and complete, and that any requested time or price adjustment is the entire adjustment to which Contractor believes it is entitled as a result of said event.

3. *Engineer's Initial Review:* Engineer will advise Owner regarding the Change Proposal, and consider any comments or response from Owner regarding the Change Proposal. If in its discretion Engineer concludes that additional supporting data is needed before conducting a full review and making a decision regarding the Change Proposal, then Engineer may request that Contractor submit such additional supporting data by a date specified by Engineer, prior to Engineer beginning its full review of the Change Proposal.
4. *Engineer's Full Review and Action on the Change Proposal:* Upon receipt of Contractor's supporting data (including any additional data requested by Engineer), Engineer will conduct a full review of each Change Proposal and, within 30 days after such receipt of the Contractor's supporting data, either approve the Change Proposal in whole, deny it in whole, or approve it in part and deny it in part. Such actions must be in writing, with a copy provided to Owner and Contractor. If Engineer does not take action on the Change



Proposal within 30 days, then either Owner or Contractor may at any time thereafter submit a letter to the other party indicating that as a result of Engineer's inaction the Change Proposal is deemed denied, thereby commencing the time for appeal of the denial under Article 12.

5. *Binding Decision*: Engineer's decision is final and binding upon Owner and Contractor, unless Owner or Contractor appeals the decision by filing a Claim under Article 12.
- C. *Resolution of Certain Change Proposals*: If the Change Proposal does not involve the design (as set forth in the Drawings, Specifications, or otherwise), the acceptability of the Work, or other engineering or technical matters, then Engineer will notify the parties in writing that the Engineer is unable to resolve the Change Proposal. For purposes of further resolution of such a Change Proposal, such notice will be deemed a denial, and Contractor may choose to seek resolution under the terms of Article 12.
- D. *Post-Completion*: Contractor shall not submit any Change Proposals after Engineer issues a written recommendation of final payment pursuant to Paragraph 15.06.B.

#### 11.10 *Notification to Surety*

- A. If the provisions of any bond require notice to be given to a surety of any change affecting the general scope of the Work or the provisions of the Contract Documents (including, but not limited to, Contract Price or Contract Times), the giving of any such notice will be Contractor's responsibility. The amount of each applicable bond will be adjusted to reflect the effect of any such change.

### **ARTICLE 12—CLAIMS**

#### 12.01 *Claims*

- A. *Claims Process*: The following disputes between Owner and Contractor are subject to the Claims process set forth in this article:
  1. Appeals by Owner or Contractor of Engineer's decisions regarding Change Proposals;
  2. Owner demands for adjustments in the Contract Price or Contract Times, or other relief under the Contract Documents;
  3. Disputes that Engineer has been unable to address because they do not involve the design (as set forth in the Drawings, Specifications, or otherwise), the acceptability of the Work, or other engineering or technical matters; and
  4. Subject to the waiver provisions of Paragraph 15.07, any dispute arising after Engineer has issued a written recommendation of final payment pursuant to Paragraph 15.06.B.
- B. *Submittal of Claim*: The party submitting a Claim shall deliver it directly to the other party to the Contract promptly (but in no event later than 30 days) after the start of the event giving rise thereto; in the case of appeals regarding Change Proposals within 30 days of the decision under appeal. The party submitting the Claim shall also furnish a copy to the Engineer, for its information only. The responsibility to substantiate a Claim rests with the party making the Claim. In the case of a Claim by Contractor seeking an increase in the Contract Times or Contract Price, Contractor shall certify that the Claim is made in good faith, that the supporting data are accurate and complete, and that to the best of Contractor's knowledge

and belief the amount of time or money requested accurately reflects the full amount to which Contractor is entitled.

- C. *Review and Resolution*: The party receiving a Claim shall review it thoroughly, giving full consideration to its merits. The two parties shall seek to resolve the Claim through the exchange of information and direct negotiations. The parties may extend the time for resolving the Claim by mutual agreement. All actions taken on a Claim will be stated in writing and submitted to the other party, with a copy to Engineer.
- D. *Mediation*
  - 1. At any time after initiation of a Claim, Owner and Contractor may mutually agree to mediation of the underlying dispute. The agreement to mediate will stay the Claim submittal and response process.
  - 2. If Owner and Contractor agree to mediation, then after 60 days from such agreement, either Owner or Contractor may unilaterally terminate the mediation process, and the Claim submittal and decision process will resume as of the date of the termination. If the mediation proceeds but is unsuccessful in resolving the dispute, the Claim submittal and decision process will resume as of the date of the conclusion of the mediation, as determined by the mediator.
  - 3. Owner and Contractor shall each pay one-half of the mediator's fees and costs.
- E. *Partial Approval*: If the party receiving a Claim approves the Claim in part and denies it in part, such action will be final and binding unless within 30 days of such action the other party invokes the procedure set forth in Article 17 for final resolution of disputes.
- F. *Denial of Claim*: If efforts to resolve a Claim are not successful, the party receiving the Claim may deny it by giving written notice of denial to the other party. If the receiving party does not take action on the Claim within 90 days, then either Owner or Contractor may at any time thereafter submit a letter to the other party indicating that as a result of the inaction, the Claim is deemed denied, thereby commencing the time for appeal of the denial. A denial of the Claim will be final and binding unless within 30 days of the denial the other party invokes the procedure set forth in Article 17 for the final resolution of disputes.
- G. *Final and Binding Results*: If the parties reach a mutual agreement regarding a Claim, whether through approval of the Claim, direct negotiations, mediation, or otherwise; or if a Claim is approved in part and denied in part, or denied in full, and such actions become final and binding; then the results of the agreement or action on the Claim will be incorporated in a Change Order or other written document to the extent they affect the Contract, including the Work, the Contract Times, or the Contract Price.

## **ARTICLE 13—COST OF THE WORK; ALLOWANCES; UNIT PRICE WORK**

### **13.01 *Cost of the Work***

- A. *Purposes for Determination of Cost of the Work*: The term Cost of the Work means the sum of all costs necessary for the proper performance of the Work at issue, as further defined below. The provisions of this Paragraph 13.01 are used for two distinct purposes:
  - 1. To determine Cost of the Work when Cost of the Work is a component of the Contract Price, under cost-plus-fee, time-and-materials, or other cost-based terms; or

2. When needed to determine the value of a Change Order, Change Proposal, Claim, set-off, or other adjustment in Contract Price. When the value of any such adjustment is determined on the basis of Cost of the Work, Contractor is entitled only to those additional or incremental costs required because of the change in the Work or because of the event giving rise to the adjustment.
- B. *Costs Included*: Except as otherwise may be agreed to in writing by Owner, costs included in the Cost of the Work will be in amounts no higher than those commonly incurred in the locality of the Project, will not include any of the costs itemized in Paragraph 13.01.C, and will include only the following items:
1. Payroll costs for employees in the direct employ of Contractor in the performance of the Work under schedules of job classifications agreed upon by Owner and Contractor in advance of the subject Work. Such employees include, without limitation, superintendents, foremen, safety managers, safety representatives, and other personnel employed full time on the Work. Payroll costs for employees not employed full time on the Work will be apportioned on the basis of their time spent on the Work. Payroll costs include, but are not limited to, salaries and wages plus the cost of fringe benefits, which include social security contributions, unemployment, excise, and payroll taxes, workers' compensation, health and retirement benefits, sick leave, and vacation and holiday pay applicable thereto. The expenses of performing Work outside of regular working hours, on Saturday, Sunday, or legal holidays, will be included in the above to the extent authorized by Owner.
  2. Cost of all materials and equipment furnished and incorporated in the Work, including costs of transportation and storage thereof, and Suppliers' field services required in connection therewith. All cash discounts accrue to Contractor unless Owner deposits funds with Contractor with which to make payments, in which case the cash discounts will accrue to Owner. All trade discounts, rebates, and refunds and returns from sale of surplus materials and equipment will accrue to Owner, and Contractor shall make provisions so that they may be obtained.
  3. Payments made by Contractor to Subcontractors for Work performed by Subcontractors. If required by Owner, Contractor shall obtain competitive bids from subcontractors acceptable to Owner and Contractor and shall deliver such bids to Owner, which will then determine, with the advice of Engineer, which bids, if any, will be acceptable. If any subcontract provides that the Subcontractor is to be paid on the basis of Cost of the Work plus a fee, the Subcontractor's Cost of the Work and fee will be determined in the same manner as Contractor's Cost of the Work and fee as provided in this Paragraph 13.01.
  4. Costs of special consultants (including but not limited to engineers, architects, testing laboratories, surveyors, attorneys, and accountants) employed or retained for services specifically related to the Work.
  5. Other costs consisting of the following:
    - a. The proportion of necessary transportation, travel, and subsistence expenses of Contractor's employees incurred in discharge of duties connected with the Work.
    - b. Cost, including transportation and maintenance, of all materials, supplies, equipment, machinery, appliances, office, and temporary facilities at the Site, which are

consumed in the performance of the Work, and cost, less market value, of such items used but not consumed which remain the property of Contractor.

- 1) In establishing included costs for materials such as scaffolding, plating, or sheeting, consideration will be given to the actual or the estimated life of the material for use on other projects; or rental rates may be established on the basis of purchase or salvage value of such items, whichever is less. Contractor will not be eligible for compensation for such items in an amount that exceeds the purchase cost of such item.

c. *Construction Equipment Rental*

- 1) Rentals of all construction equipment and machinery, and the parts thereof, in accordance with rental agreements approved by Owner as to price (including any surcharge or special rates applicable to overtime use of the construction equipment or machinery), and the costs of transportation, loading, unloading, assembly, dismantling, and removal thereof. All such costs will be in accordance with the terms of said rental agreements. The rental of any such equipment, machinery, or parts must cease when the use thereof is no longer necessary for the Work.
  - 2) Costs for equipment and machinery owned by Contractor or a Contractor-related entity will be paid at a rate shown for such equipment in the equipment rental rate book specified in the Supplementary Conditions. An hourly rate will be computed by dividing the monthly rates by 176. These computed rates will include all operating costs.
  - 3) With respect to Work that is the result of a Change Order, Change Proposal, Claim, set-off, or other adjustment in Contract Price ("changed Work"), included costs will be based on the time the equipment or machinery is in use on the changed Work and the costs of transportation, loading, unloading, assembly, dismantling, and removal when directly attributable to the changed Work. The cost of any such equipment or machinery, or parts thereof, must cease to accrue when the use thereof is no longer necessary for the changed Work.
- d. Sales, consumer, use, and other similar taxes related to the Work, and for which Contractor is liable, as imposed by Laws and Regulations.
- e. Deposits lost for causes other than negligence of Contractor, any Subcontractor, or anyone directly or indirectly employed by any of them or for whose acts any of them may be liable, and royalty payments and fees for permits and licenses.
- f. Losses and damages (and related expenses) caused by damage to the Work, not compensated by insurance or otherwise, sustained by Contractor in connection with the performance of the Work (except losses and damages within the deductible amounts of builder's risk or other property insurance established in accordance with Paragraph 6.04), provided such losses and damages have resulted from causes other than the negligence of Contractor, any Subcontractor, or anyone directly or indirectly employed by any of them or for whose acts any of them may be liable. Such losses include settlements made with the written consent and approval of Owner. No such losses, damages, and expenses will be included in the Cost of the Work for the purpose of determining Contractor's fee.

- g. The cost of utilities, fuel, and sanitary facilities at the Site.
  - h. Minor expenses such as communication service at the Site, express and courier services, and similar petty cash items in connection with the Work.
  - i. The costs of premiums for all bonds and insurance that Contractor is required by the Contract Documents to purchase and maintain.
- C. *Costs Excluded*: The term Cost of the Work does not include any of the following items:
- 1. Payroll costs and other compensation of Contractor's officers, executives, principals, general managers, engineers, architects, estimators, attorneys, auditors, accountants, purchasing and contracting agents, expeditors, timekeepers, clerks, and other personnel employed by Contractor, whether at the Site or in Contractor's principal or branch office for general administration of the Work and not specifically included in the agreed upon schedule of job classifications referred to in Paragraph 13.01.B.1 or specifically covered by Paragraph 13.01.B.4. The payroll costs and other compensation excluded here are to be considered administrative costs covered by the Contractor's fee.
  - 2. The cost of purchasing, renting, or furnishing small tools and hand tools.
  - 3. Expenses of Contractor's principal and branch offices other than Contractor's office at the Site.
  - 4. Any part of Contractor's capital expenses, including interest on Contractor's capital employed for the Work and charges against Contractor for delinquent payments.
  - 5. Costs due to the negligence of Contractor, any Subcontractor, or anyone directly or indirectly employed by any of them or for whose acts any of them may be liable, including but not limited to, the correction of defective Work, disposal of materials or equipment wrongly supplied, and making good any damage to property.
  - 6. Expenses incurred in preparing and advancing Claims.
  - 7. Other overhead or general expense costs of any kind and the costs of any item not specifically and expressly included in Paragraph 13.01.B.
- D. *Contractor's Fee*
- 1. When the Work as a whole is performed on the basis of cost-plus-a-fee, then:
    - a. Contractor's fee for the Work set forth in the Contract Documents as of the Effective Date of the Contract will be determined as set forth in the Agreement.
    - b. for any Work covered by a Change Order, Change Proposal, Claim, set-off, or other adjustment in Contract Price on the basis of Cost of the Work, Contractor's fee will be determined as follows:
      - 1) When the fee for the Work as a whole is a percentage of the Cost of the Work, the fee will automatically adjust as the Cost of the Work changes.
      - 2) When the fee for the Work as a whole is a fixed fee, the fee for any additions or deletions will be determined in accordance with Paragraph 11.07.C.2.
  - 2. When the Work as a whole is performed on the basis of a stipulated sum, or any other basis other than cost-plus-a-fee, then Contractor's fee for any Work covered by a Change

Order, Change Proposal, Claim, set-off, or other adjustment in Contract Price on the basis of Cost of the Work will be determined in accordance with Paragraph 11.07.C.2.

- E. *Documentation and Audit*: Whenever the Cost of the Work for any purpose is to be determined pursuant to this Article 13, Contractor and pertinent Subcontractors will establish and maintain records of the costs in accordance with generally accepted accounting practices. Subject to prior written notice, Owner will be afforded reasonable access, during normal business hours, to all Contractor's accounts, records, books, correspondence, instructions, drawings, receipts, vouchers, memoranda, and similar data relating to the Cost of the Work and Contractor's fee. Contractor shall preserve all such documents for a period of three years after the final payment by Owner. Pertinent Subcontractors will afford such access to Owner, and preserve such documents, to the same extent required of Contractor.

### 13.02 Allowances

- A. It is understood that Contractor has included in the Contract Price all allowances so named in the Contract Documents and shall cause the Work so covered to be performed for such sums and by such persons or entities as may be acceptable to Owner and Engineer.
- B. *Cash Allowances*: Contractor agrees that:
1. the cash allowances include the cost to Contractor (less any applicable trade discounts) of materials and equipment required by the allowances to be delivered at the Site, and all applicable taxes; and
  2. Contractor's costs for unloading and handling on the Site, labor, installation, overhead, profit, and other expenses contemplated for the cash allowances have been included in the Contract Price and not in the allowances, and no demand for additional payment for any of the foregoing will be valid.
- C. *Owner's Contingency Allowance*: Contractor agrees that an Owner's contingency allowance, if any, is for the sole use of Owner to cover unanticipated costs.
- D. Prior to final payment, an appropriate Change Order will be issued as recommended by Engineer to reflect actual amounts due Contractor for Work covered by allowances, and the Contract Price will be correspondingly adjusted.

### 13.03 Unit Price Work

- A. Where the Contract Documents provide that all or part of the Work is to be Unit Price Work, initially the Contract Price will be deemed to include for all Unit Price Work an amount equal to the sum of the unit price for each separately identified item of Unit Price Work times the estimated quantity of each item as indicated in the Agreement.
- B. The estimated quantities of items of Unit Price Work are not guaranteed and are solely for the purpose of comparison of Bids and determining an initial Contract Price. Payments to Contractor for Unit Price Work will be based on actual quantities.
- C. Each unit price will be deemed to include an amount considered by Contractor to be adequate to cover Contractor's overhead and profit for each separately identified item.
- D. Engineer will determine the actual quantities and classifications of Unit Price Work performed by Contractor. Engineer will review with Contractor the Engineer's preliminary determinations on such matters before rendering a written decision thereon (by recommendation of an Application for Payment or otherwise). Engineer's written decision

thereon will be final and binding (except as modified by Engineer to reflect changed factual conditions or more accurate data) upon Owner and Contractor, and the final adjustment of Contract Price will be set forth in a Change Order, subject to the provisions of the following paragraph.

E. *Adjustments in Unit Price*

1. Contractor or Owner shall be entitled to an adjustment in the unit price with respect to an item of Unit Price Work if:
  - a. the quantity of the item of Unit Price Work performed by Contractor differs materially and significantly from the estimated quantity of such item indicated in the Agreement; and
  - b. Contractor's unit costs to perform the item of Unit Price Work have changed materially and significantly as a result of the quantity change.
2. The adjustment in unit price will account for and be coordinated with any related changes in quantities of other items of Work, and in Contractor's costs to perform such other Work, such that the resulting overall change in Contract Price is equitable to Owner and Contractor.
3. Adjusted unit prices will apply to all units of that item.

**ARTICLE 14—TESTS AND INSPECTIONS; CORRECTION, REMOVAL, OR ACCEPTANCE OF DEFECTIVE WORK**

14.01 *Access to Work*

- A. Owner, Engineer, their consultants and other representatives and personnel of Owner, independent testing laboratories, and authorities having jurisdiction have access to the Site and the Work at reasonable times for their observation, inspection, and testing. Contractor shall provide them proper and safe conditions for such access and advise them of Contractor's safety procedures and programs so that they may comply with such procedures and programs as applicable.

14.02 *Tests, Inspections, and Approvals*

- A. Contractor shall give Engineer timely notice of readiness of the Work (or specific parts thereof) for all required inspections and tests, and shall cooperate with inspection and testing personnel to facilitate required inspections and tests.
- B. Owner shall retain and pay for the services of an independent inspector, testing laboratory, or other qualified individual or entity to perform all inspections and tests expressly required by the Contract Documents to be furnished and paid for by Owner, except that costs incurred in connection with tests or inspections of covered Work will be governed by the provisions of Paragraph 14.05.
- C. If Laws or Regulations of any public body having jurisdiction require any Work (or part thereof) specifically to be inspected, tested, or approved by an employee or other representative of such public body, Contractor shall assume full responsibility for arranging and obtaining such inspections, tests, or approvals, pay all costs in connection therewith, and furnish Engineer the required certificates of inspection or approval.



- D. Contractor shall be responsible for arranging, obtaining, and paying for all inspections and tests required:
1. by the Contract Documents, unless the Contract Documents expressly allocate responsibility for a specific inspection or test to Owner;
  2. to attain Owner's and Engineer's acceptance of materials or equipment to be incorporated in the Work;
  3. by manufacturers of equipment furnished under the Contract Documents;
  4. for testing, adjusting, and balancing of mechanical, electrical, and other equipment to be incorporated into the Work; and
  5. for acceptance of materials, mix designs, or equipment submitted for approval prior to Contractor's purchase thereof for incorporation in the Work.

Such inspections and tests will be performed by independent inspectors, testing laboratories, or other qualified individuals or entities acceptable to Owner and Engineer.

- E. If the Contract Documents require the Work (or part thereof) to be approved by Owner, Engineer, or another designated individual or entity, then Contractor shall assume full responsibility for arranging and obtaining such approvals.
- F. If any Work (or the work of others) that is to be inspected, tested, or approved is covered by Contractor without written concurrence of Engineer, Contractor shall, if requested by Engineer, uncover such Work for observation. Such uncovering will be at Contractor's expense unless Contractor had given Engineer timely notice of Contractor's intention to cover the same and Engineer had not acted with reasonable promptness in response to such notice.

#### 14.03 Defective Work

- A. *Contractor's Obligation:* It is Contractor's obligation to assure that the Work is not defective.
- B. *Engineer's Authority:* Engineer has the authority to determine whether Work is defective, and to reject defective Work.
- C. *Notice of Defects:* Prompt written notice of all defective Work of which Owner or Engineer has actual knowledge will be given to Contractor.
- D. *Correction, or Removal and Replacement:* Promptly after receipt of written notice of defective Work, Contractor shall correct all such defective Work, whether or not fabricated, installed, or completed, or, if Engineer has rejected the defective Work, remove it from the Project and replace it with Work that is not defective.
- E. *Preservation of Warranties:* When correcting defective Work, Contractor shall take no action that would void or otherwise impair Owner's special warranty and guarantee, if any, on said Work.
- F. *Costs and Damages:* In addition to its correction, removal, and replacement obligations with respect to defective Work, Contractor shall pay all claims, costs, losses, and damages arising out of or relating to defective Work, including but not limited to the cost of the inspection, testing, correction, removal, replacement, or reconstruction of such defective Work, fines levied against Owner by governmental authorities because the Work is defective, and the costs of repair or replacement of work of others resulting from defective Work. Prior to final payment, if Owner and Contractor are unable to agree as to the measure of such claims, costs,

losses, and damages resulting from defective Work, then Owner may impose a reasonable set-off against payments due under Article 15.

#### 14.04 *Acceptance of Defective Work*

- A. If, instead of requiring correction or removal and replacement of defective Work, Owner prefers to accept it, Owner may do so (subject, if such acceptance occurs prior to final payment, to Engineer's confirmation that such acceptance is in general accord with the design intent and applicable engineering principles, and will not endanger public safety). Contractor shall pay all claims, costs, losses, and damages attributable to Owner's evaluation of and determination to accept such defective Work (such costs to be approved by Engineer as to reasonableness), and for the diminished value of the Work to the extent not otherwise paid by Contractor. If any such acceptance occurs prior to final payment, the necessary revisions in the Contract Documents with respect to the Work will be incorporated in a Change Order. If the parties are unable to agree as to the decrease in the Contract Price, reflecting the diminished value of Work so accepted, then Owner may impose a reasonable set-off against payments due under Article 15. If the acceptance of defective Work occurs after final payment, Contractor shall pay an appropriate amount to Owner.

#### 14.05 *Uncovering Work*

- A. Engineer has the authority to require additional inspection or testing of the Work, whether or not the Work is fabricated, installed, or completed.
- B. If any Work is covered contrary to the written request of Engineer, then Contractor shall, if requested by Engineer, uncover such Work for Engineer's observation, and then replace the covering, all at Contractor's expense.
- C. If Engineer considers it necessary or advisable that covered Work be observed by Engineer or inspected or tested by others, then Contractor, at Engineer's request, shall uncover, expose, or otherwise make available for observation, inspection, or testing as Engineer may require, that portion of the Work in question, and provide all necessary labor, material, and equipment.
  1. If it is found that the uncovered Work is defective, Contractor shall be responsible for all claims, costs, losses, and damages arising out of or relating to such uncovering, exposure, observation, inspection, and testing, and of satisfactory replacement or reconstruction (including but not limited to all costs of repair or replacement of work of others); and pending Contractor's full discharge of this responsibility the Owner shall be entitled to impose a reasonable set-off against payments due under Article 15.
  2. If the uncovered Work is not found to be defective, Contractor shall be allowed an increase in the Contract Price or an extension of the Contract Times, directly attributable to such uncovering, exposure, observation, inspection, testing, replacement, and reconstruction. If the parties are unable to agree as to the amount or extent thereof, then Contractor may submit a Change Proposal within 30 days of the determination that the Work is not defective.

#### 14.06 *Owner May Stop the Work*

- A. If the Work is defective, or Contractor fails to supply sufficient skilled workers or suitable materials or equipment, or fails to perform the Work in such a way that the completed Work will conform to the Contract Documents, then Owner may order Contractor to stop the Work,

or any portion thereof, until the cause for such order has been eliminated; however, this right of Owner to stop the Work will not give rise to any duty on the part of Owner to exercise this right for the benefit of Contractor, any Subcontractor, any Supplier, any other individual or entity, or any surety for, or employee or agent of any of them.

**14.07 Owner May Correct Defective Work**

- A. If Contractor fails within a reasonable time after written notice from Engineer to correct defective Work, or to remove and replace defective Work as required by Engineer, then Owner may, after 7 days' written notice to Contractor, correct or remedy any such deficiency.
- B. In exercising the rights and remedies under this Paragraph 14.07, Owner shall proceed expeditiously. In connection with such corrective or remedial action, Owner may exclude Contractor from all or part of the Site, take possession of all or part of the Work and suspend Contractor's services related thereto, and incorporate in the Work all materials and equipment stored at the Site or for which Owner has paid Contractor but which are stored elsewhere. Contractor shall allow Owner, Owner's representatives, agents and employees, Owner's other contractors, and Engineer and Engineer's consultants access to the Site to enable Owner to exercise the rights and remedies under this paragraph.
- C. All claims, costs, losses, and damages incurred or sustained by Owner in exercising the rights and remedies under this Paragraph 14.07 will be charged against Contractor as set-offs against payments due under Article 15. Such claims, costs, losses and damages will include but not be limited to all costs of repair, or replacement of work of others destroyed or damaged by correction, removal, or replacement of Contractor's defective Work.
- D. Contractor shall not be allowed an extension of the Contract Times because of any delay in the performance of the Work attributable to the exercise by Owner of Owner's rights and remedies under this Paragraph 14.07.

**ARTICLE 15—PAYMENTS TO CONTRACTOR; SET-OFFS; COMPLETION; CORRECTION PERIOD**

**15.01 Progress Payments**

- A. *Basis for Progress Payments:* The Schedule of Values established as provided in Article 2 will serve as the basis for progress payments and will be incorporated into a form of Application for Payment acceptable to Engineer. Progress payments for Unit Price Work will be based on the number of units completed during the pay period, as determined under the provisions of Paragraph 13.03. Progress payments for cost-based Work will be based on Cost of the Work completed by Contractor during the pay period.
- B. *Applications for Payments*
  - 1. At least 20 days before the date established in the Agreement for each progress payment (but not more often than once a month), Contractor shall submit to Engineer for review an Application for Payment filled out and signed by Contractor covering the Work completed as of the date of the Application and accompanied by such supporting documentation as is required by the Contract Documents.
  - 2. If payment is requested on the basis of materials and equipment not incorporated in the Work but delivered and suitably stored at the Site or at another location agreed to in writing, the Application for Payment must also be accompanied by: (a) a bill of sale, invoice, copies of subcontract or purchase order payments, or other documentation

establishing full payment by Contractor for the materials and equipment; (b) at Owner's request, documentation warranting that Owner has received the materials and equipment free and clear of all Liens; and (c) evidence that the materials and equipment are covered by appropriate property insurance, a warehouse bond, or other arrangements to protect Owner's interest therein, all of which must be satisfactory to Owner.

3. Beginning with the second Application for Payment, each Application must include an affidavit of Contractor stating that all previous progress payments received by Contractor have been applied to discharge Contractor's legitimate obligations associated with prior Applications for Payment.
4. The amount of retainage with respect to progress payments will be as stipulated in the Agreement.

C. *Review of Applications*

1. Engineer will, within 10 days after receipt of each Application for Payment, including each resubmittal, either indicate in writing a recommendation of payment and present the Application to Owner, or return the Application to Contractor indicating in writing Engineer's reasons for refusing to recommend payment. In the latter case, Contractor may make the necessary corrections and resubmit the Application.
2. Engineer's recommendation of any payment requested in an Application for Payment will constitute a representation by Engineer to Owner, based on Engineer's observations of the executed Work as an experienced and qualified design professional, and on Engineer's review of the Application for Payment and the accompanying data and schedules, that to the best of Engineer's knowledge, information and belief:
  - a. the Work has progressed to the point indicated;
  - b. the quality of the Work is generally in accordance with the Contract Documents (subject to an evaluation of the Work as a functioning whole prior to or upon Substantial Completion, the results of any subsequent tests called for in the Contract Documents, a final determination of quantities and classifications for Unit Price Work under Paragraph 13.03, and any other qualifications stated in the recommendation); and
  - c. the conditions precedent to Contractor's being entitled to such payment appear to have been fulfilled in so far as it is Engineer's responsibility to observe the Work.
3. By recommending any such payment Engineer will not thereby be deemed to have represented that:
  - a. inspections made to check the quality or the quantity of the Work as it has been performed have been exhaustive, extended to every aspect of the Work in progress, or involved detailed inspections of the Work beyond the responsibilities specifically assigned to Engineer in the Contract; or
  - b. there may not be other matters or issues between the parties that might entitle Contractor to be paid additionally by Owner or entitle Owner to withhold payment to Contractor.

4. Neither Engineer's review of Contractor's Work for the purposes of recommending payments nor Engineer's recommendation of any payment, including final payment, will impose responsibility on Engineer:
  - a. to supervise, direct, or control the Work;
  - b. for the means, methods, techniques, sequences, or procedures of construction, or the safety precautions and programs incident thereto;
  - c. for Contractor's failure to comply with Laws and Regulations applicable to Contractor's performance of the Work;
  - d. to make any examination to ascertain how or for what purposes Contractor has used the money paid by Owner; or
  - e. to determine that title to any of the Work, materials, or equipment has passed to Owner free and clear of any Liens.
5. Engineer may refuse to recommend the whole or any part of any payment if, in Engineer's opinion, it would be incorrect to make the representations to Owner stated in Paragraph 15.01.C.2.
6. Engineer will recommend reductions in payment (set-offs) necessary in Engineer's opinion to protect Owner from loss because:
  - a. the Work is defective, requiring correction or replacement;
  - b. the Contract Price has been reduced by Change Orders;
  - c. Owner has been required to correct defective Work in accordance with Paragraph 14.07, or has accepted defective Work pursuant to Paragraph 14.04;
  - d. Owner has been required to remove or remediate a Hazardous Environmental Condition for which Contractor is responsible; or
  - e. Engineer has actual knowledge of the occurrence of any of the events that would constitute a default by Contractor and therefore justify termination for cause under the Contract Documents.

D. *Payment Becomes Due*

1. Ten days after presentation of the Application for Payment to Owner with Engineer's recommendation, the amount recommended (subject to any Owner set-offs) will become due, and when due will be paid by Owner to Contractor.

E. *Reductions in Payment by Owner*

1. In addition to any reductions in payment (set-offs) recommended by Engineer, Owner is entitled to impose a set-off against payment based on any of the following:
  - a. Claims have been made against Owner based on Contractor's conduct in the performance or furnishing of the Work, or Owner has incurred costs, losses, or damages resulting from Contractor's conduct in the performance or furnishing of the Work, including but not limited to claims, costs, losses, or damages from workplace injuries, adjacent property damage, non-compliance with Laws and Regulations, and patent infringement;

- b. Contractor has failed to take reasonable and customary measures to avoid damage, delay, disruption, and interference with other work at or adjacent to the Site;
  - c. Contractor has failed to provide and maintain required bonds or insurance;
  - d. Owner has been required to remove or remediate a Hazardous Environmental Condition for which Contractor is responsible;
  - e. Owner has incurred extra charges or engineering costs related to submittal reviews, evaluations of proposed substitutes, tests and inspections, or return visits to manufacturing or assembly facilities;
  - f. The Work is defective, requiring correction or replacement;
  - g. Owner has been required to correct defective Work in accordance with Paragraph 14.07, or has accepted defective Work pursuant to Paragraph 14.04;
  - h. The Contract Price has been reduced by Change Orders;
  - i. An event has occurred that would constitute a default by Contractor and therefore justify a termination for cause;
  - j. Liquidated or other damages have accrued as a result of Contractor's failure to achieve Milestones, Substantial Completion, or final completion of the Work;
  - k. Liens have been filed in connection with the Work, except where Contractor has delivered a specific bond satisfactory to Owner to secure the satisfaction and discharge of such Liens; or
  - l. Other items entitle Owner to a set-off against the amount recommended.
2. If Owner imposes any set-off against payment, whether based on its own knowledge or on the written recommendations of Engineer, Owner will give Contractor immediate written notice (with a copy to Engineer) stating the reasons for such action and the specific amount of the reduction, and promptly pay Contractor any amount remaining after deduction of the amount so withheld. Owner shall promptly pay Contractor the amount so withheld, or any adjustment thereto agreed to by Owner and Contractor, if Contractor remedies the reasons for such action. The reduction imposed will be binding on Contractor unless it duly submits a Change Proposal contesting the reduction.
3. Upon a subsequent determination that Owner's refusal of payment was not justified, the amount wrongfully withheld will be treated as an amount due as determined by Paragraph 15.01.D.1 and subject to interest as provided in the Agreement.

15.02 *Contractor's Warranty of Title*

- A. Contractor warrants and guarantees that title to all Work, materials, and equipment furnished under the Contract will pass to Owner free and clear of (1) all Liens and other title defects, and (2) all patent, licensing, copyright, or royalty obligations, no later than 7 days after the time of payment by Owner.

15.03 *Substantial Completion*

- A. When Contractor considers the entire Work ready for its intended use Contractor shall notify Owner and Engineer in writing that the entire Work is substantially complete and request that Engineer issue a certificate of Substantial Completion. Contractor shall at the same time

submit to Owner and Engineer an initial draft of punch list items to be completed or corrected before final payment.

- B. Promptly after Contractor's notification, Owner, Contractor, and Engineer shall make an inspection of the Work to determine the status of completion. If Engineer does not consider the Work substantially complete, Engineer will notify Contractor in writing giving the reasons therefor.
- C. If Engineer considers the Work substantially complete, Engineer will deliver to Owner a preliminary certificate of Substantial Completion which will fix the date of Substantial Completion. Engineer shall attach to the certificate a punch list of items to be completed or corrected before final payment. Owner shall have 7 days after receipt of the preliminary certificate during which to make written objection to Engineer as to any provisions of the certificate or attached punch list. If, after considering the objections to the provisions of the preliminary certificate, Engineer concludes that the Work is not substantially complete, Engineer will, within 14 days after submission of the preliminary certificate to Owner, notify Contractor in writing that the Work is not substantially complete, stating the reasons therefor. If Owner does not object to the provisions of the certificate, or if despite consideration of Owner's objections Engineer concludes that the Work is substantially complete, then Engineer will, within said 14 days, execute and deliver to Owner and Contractor a final certificate of Substantial Completion (with a revised punch list of items to be completed or corrected) reflecting such changes from the preliminary certificate as Engineer believes justified after consideration of any objections from Owner.
- D. At the time of receipt of the preliminary certificate of Substantial Completion, Owner and Contractor will confer regarding Owner's use or occupancy of the Work following Substantial Completion, review the builder's risk insurance policy with respect to the end of the builder's risk coverage, and confirm the transition to coverage of the Work under a permanent property insurance policy held by Owner. Unless Owner and Contractor agree otherwise in writing, Owner shall bear responsibility for security, operation, protection of the Work, property insurance, maintenance, heat, and utilities upon Owner's use or occupancy of the Work.
- E. After Substantial Completion the Contractor shall promptly begin work on the punch list of items to be completed or corrected prior to final payment. In appropriate cases Contractor may submit monthly Applications for Payment for completed punch list items, following the progress payment procedures set forth above.
- F. Owner shall have the right to exclude Contractor from the Site after the date of Substantial Completion subject to allowing Contractor reasonable access to remove its property and complete or correct items on the punch list.

15.04 *Partial Use or Occupancy*

- A. Prior to Substantial Completion of all the Work, Owner may use or occupy any substantially completed part of the Work which has specifically been identified in the Contract Documents, or which Owner, Engineer, and Contractor agree constitutes a separately functioning and usable part of the Work that can be used by Owner for its intended purpose without



significant interference with Contractor's performance of the remainder of the Work, subject to the following conditions:

1. At any time, Owner may request in writing that Contractor permit Owner to use or occupy any such part of the Work that Owner believes to be substantially complete. If and when Contractor agrees that such part of the Work is substantially complete, Contractor, Owner, and Engineer will follow the procedures of Paragraph 15.03.A through 15.03.E for that part of the Work.
2. At any time, Contractor may notify Owner and Engineer in writing that Contractor considers any such part of the Work substantially complete and request Engineer to issue a certificate of Substantial Completion for that part of the Work.
3. Within a reasonable time after either such request, Owner, Contractor, and Engineer shall make an inspection of that part of the Work to determine its status of completion. If Engineer does not consider that part of the Work to be substantially complete, Engineer will notify Owner and Contractor in writing giving the reasons therefor. If Engineer considers that part of the Work to be substantially complete, the provisions of Paragraph 15.03 will apply with respect to certification of Substantial Completion of that part of the Work and the division of responsibility in respect thereof and access thereto.
4. No use or occupancy or separate operation of part of the Work may occur prior to compliance with the requirements of Paragraph 6.04 regarding builder's risk or other property insurance.

15.05 *Final Inspection*

- A. Upon written notice from Contractor that the entire Work or an agreed portion thereof is complete, Engineer will promptly make a final inspection with Owner and Contractor and will notify Contractor in writing of all particulars in which this inspection reveals that the Work, or agreed portion thereof, is incomplete or defective. Contractor shall immediately take such measures as are necessary to complete such Work or remedy such deficiencies.

15.06 *Final Payment*

A. *Application for Payment*

1. After Contractor has, in the opinion of Engineer, satisfactorily completed all corrections identified during the final inspection and has delivered, in accordance with the Contract Documents, all maintenance and operating instructions, schedules, guarantees, bonds, certificates or other evidence of insurance, certificates of inspection, annotated record documents (as provided in Paragraph 7.12), and other documents, Contractor may make application for final payment.
2. The final Application for Payment must be accompanied (except as previously delivered) by:
  - a. all documentation called for in the Contract Documents;
  - b. consent of the surety, if any, to final payment;
  - c. satisfactory evidence that all title issues have been resolved such that title to all Work, materials, and equipment has passed to Owner free and clear of any Liens or other title defects, or will so pass upon final payment.

- d. a list of all duly pending Change Proposals and Claims; and
  - e. complete and legally effective releases or waivers (satisfactory to Owner) of all Lien rights arising out of the Work, and of Liens filed in connection with the Work.
3. In lieu of the releases or waivers of Liens specified in Paragraph 15.06.A.2 and as approved by Owner, Contractor may furnish receipts or releases in full and an affidavit of Contractor that: (a) the releases and receipts include all labor, services, material, and equipment for which a Lien could be filed; and (b) all payrolls, material and equipment bills, and other indebtedness connected with the Work for which Owner might in any way be responsible, or which might in any way result in liens or other burdens on Owner's property, have been paid or otherwise satisfied. If any Subcontractor or Supplier fails to furnish such a release or receipt in full, Contractor may furnish a bond or other collateral satisfactory to Owner to indemnify Owner against any Lien, or Owner at its option may issue joint checks payable to Contractor and specified Subcontractors and Suppliers.
- B. *Engineer's Review of Final Application and Recommendation of Payment:* If, on the basis of Engineer's observation of the Work during construction and final inspection, and Engineer's review of the final Application for Payment and accompanying documentation as required by the Contract Documents, Engineer is satisfied that the Work has been completed and Contractor's other obligations under the Contract have been fulfilled, Engineer will, within 10 days after receipt of the final Application for Payment, indicate in writing Engineer's recommendation of final payment and present the final Application for Payment to Owner for payment. Such recommendation will account for any set-offs against payment that are necessary in Engineer's opinion to protect Owner from loss for the reasons stated above with respect to progress payments. Otherwise, Engineer will return the Application for Payment to Contractor, indicating in writing the reasons for refusing to recommend final payment, in which case Contractor shall make the necessary corrections and resubmit the Application for Payment.
- C. *Notice of Acceptability:* In support of its recommendation of payment of the final Application for Payment, Engineer will also give written notice to Owner and Contractor that the Work is acceptable, subject to stated limitations in the notice and to the provisions of Paragraph 15.07.
- D. *Completion of Work:* The Work is complete (subject to surviving obligations) when it is ready for final payment as established by the Engineer's written recommendation of final payment and issuance of notice of the acceptability of the Work.
- E. *Final Payment Becomes Due:* Upon receipt from Engineer of the final Application for Payment and accompanying documentation, Owner shall set off against the amount recommended by Engineer for final payment any further sum to which Owner is entitled, including but not limited to set-offs for liquidated damages and set-offs allowed under the provisions of this Contract with respect to progress payments. Owner shall pay the resulting balance due to Contractor within 30 days of Owner's receipt of the final Application for Payment from Engineer.

#### 15.07 *Waiver of Claims*

- A. By making final payment, Owner waives its claim or right to liquidated damages or other damages for late completion by Contractor, except as set forth in an outstanding Claim,

appeal under the provisions of Article 17, set-off, or express reservation of rights by Owner. Owner reserves all other claims or rights after final payment.

- B. The acceptance of final payment by Contractor will constitute a waiver by Contractor of all claims and rights against Owner other than those pending matters that have been duly submitted as a Claim, or appealed under the provisions of Article 17.

15.08 *Correction Period*

- A. If within one year after the date of Substantial Completion (or such longer period of time as may be prescribed by the Supplementary Conditions or the terms of any applicable special guarantee required by the Contract Documents), Owner gives Contractor written notice that any Work has been found to be defective, or that Contractor's repair of any damages to the Site or adjacent areas has been found to be defective, then after receipt of such notice of defect Contractor shall promptly, without cost to Owner and in accordance with Owner's written instructions:
  - 1. correct the defective repairs to the Site or such adjacent areas;
  - 2. correct such defective Work;
  - 3. remove the defective Work from the Project and replace it with Work that is not defective, if the defective Work has been rejected by Owner, and
  - 4. satisfactorily correct or repair or remove and replace any damage to other Work, to the work of others, or to other land or areas resulting from the corrective measures.
- B. Owner shall give any such notice of defect within 60 days of the discovery that such Work or repairs is defective. If such notice is given within such 60 days but after the end of the correction period, the notice will be deemed a notice of defective Work under Paragraph 7.17.B.
- C. If, after receipt of a notice of defect within 60 days and within the correction period, Contractor does not promptly comply with the terms of Owner's written instructions, or in an emergency where delay would cause serious risk of loss or damage, Owner may have the defective Work corrected or repaired or may have the rejected Work removed and replaced. Contractor shall pay all costs, losses, and damages (including but not limited to all fees and charges of engineers, architects, attorneys, and other professionals and all court or arbitration or other dispute resolution costs) arising out of or relating to such correction or repair or such removal and replacement (including but not limited to all costs of repair or replacement of work of others). Contractor's failure to pay such costs, losses, and damages within 10 days of invoice from Owner will be deemed the start of an event giving rise to a Claim under Paragraph 12.01.B, such that any related Claim must be brought within 30 days of the failure to pay.
- D. In special circumstances where a particular item of equipment is placed in continuous service before Substantial Completion of all the Work, the correction period for that item may start to run from an earlier date if so provided in the Specifications.
- E. Where defective Work (and damage to other Work resulting therefrom) has been corrected or removed and replaced under this paragraph, the correction period hereunder with respect to such Work will be extended for an additional period of one year after such correction or removal and replacement has been satisfactorily completed.

- F. Contractor's obligations under this paragraph are in addition to all other obligations and warranties. The provisions of this paragraph are not to be construed as a substitute for, or a waiver of, the provisions of any applicable statute of limitation or repose.

## ARTICLE 16—SUSPENSION OF WORK AND TERMINATION

### 16.01 *Owner May Suspend Work*

- A. At any time and without cause, Owner may suspend the Work or any portion thereof for a period of not more than 90 consecutive days by written notice to Contractor and Engineer. Such notice will fix the date on which Work will be resumed. Contractor shall resume the Work on the date so fixed. Contractor shall be entitled to an adjustment in the Contract Price or an extension of the Contract Times directly attributable to any such suspension. Any Change Proposal seeking such adjustments must be submitted no later than 30 days after the date fixed for resumption of Work.

### 16.02 *Owner May Terminate for Cause*

- A. The occurrence of any one or more of the following events will constitute a default by Contractor and justify termination for cause:
  - 1. Contractor's persistent failure to perform the Work in accordance with the Contract Documents (including, but not limited to, failure to supply sufficient skilled workers or suitable materials or equipment, or failure to adhere to the Progress Schedule);
  - 2. Failure of Contractor to perform or otherwise to comply with a material term of the Contract Documents;
  - 3. Contractor's disregard of Laws or Regulations of any public body having jurisdiction; or
  - 4. Contractor's repeated disregard of the authority of Owner or Engineer.
- B. If one or more of the events identified in Paragraph 16.02.A occurs, then after giving Contractor (and any surety) 10 days' written notice that Owner is considering a declaration that Contractor is in default and termination of the Contract, Owner may proceed to:
  - 1. declare Contractor to be in default, and give Contractor (and any surety) written notice that the Contract is terminated; and
  - 2. enforce the rights available to Owner under any applicable performance bond.
- C. Subject to the terms and operation of any applicable performance bond, if Owner has terminated the Contract for cause, Owner may exclude Contractor from the Site, take possession of the Work, incorporate in the Work all materials and equipment stored at the Site or for which Owner has paid Contractor but which are stored elsewhere, and complete the Work as Owner may deem expedient.
- D. Owner may not proceed with termination of the Contract under Paragraph 16.02.B if Contractor within 7 days of receipt of notice of intent to terminate begins to correct its failure to perform and proceeds diligently to cure such failure.
- E. If Owner proceeds as provided in Paragraph 16.02.B, Contractor shall not be entitled to receive any further payment until the Work is completed. If the unpaid balance of the Contract Price exceeds the cost to complete the Work, including all related claims, costs, losses, and damages (including but not limited to all fees and charges of engineers, architects,

attorneys, and other professionals) sustained by Owner, such excess will be paid to Contractor. If the cost to complete the Work including such related claims, costs, losses, and damages exceeds such unpaid balance, Contractor shall pay the difference to Owner. Such claims, costs, losses, and damages incurred by Owner will be reviewed by Engineer as to their reasonableness and, when so approved by Engineer, incorporated in a Change Order. When exercising any rights or remedies under this paragraph, Owner shall not be required to obtain the lowest price for the Work performed.

- F. Where Contractor's services have been so terminated by Owner, the termination will not affect any rights or remedies of Owner against Contractor then existing or which may thereafter accrue, or any rights or remedies of Owner against Contractor or any surety under any payment bond or performance bond. Any retention or payment of money due Contractor by Owner will not release Contractor from liability.
- G. If and to the extent that Contractor has provided a performance bond under the provisions of Paragraph 6.01.A, the provisions of that bond will govern over any inconsistent provisions of Paragraphs 16.02.B and 16.02.D.

#### 16.03 *Owner May Terminate for Convenience*

- A. Upon 7 days' written notice to Contractor and Engineer, Owner may, without cause and without prejudice to any other right or remedy of Owner, terminate the Contract. In such case, Contractor shall be paid for (without duplication of any items):
  - 1. completed and acceptable Work executed in accordance with the Contract Documents prior to the effective date of termination, including fair and reasonable sums for overhead and profit on such Work;
  - 2. expenses sustained prior to the effective date of termination in performing services and furnishing labor, materials, or equipment as required by the Contract Documents in connection with uncompleted Work, plus fair and reasonable sums for overhead and profit on such expenses; and
  - 3. other reasonable expenses directly attributable to termination, including costs incurred to prepare a termination for convenience cost proposal.
- B. Contractor shall not be paid for any loss of anticipated profits or revenue, post-termination overhead costs, or other economic loss arising out of or resulting from such termination.

#### 16.04 *Contractor May Stop Work or Terminate*

- A. If, through no act or fault of Contractor, (1) the Work is suspended for more than 90 consecutive days by Owner or under an order of court or other public authority, or (2) Engineer fails to act on any Application for Payment within 30 days after it is submitted, or (3) Owner fails for 30 days to pay Contractor any sum finally determined to be due, then Contractor may, upon 7 days' written notice to Owner and Engineer, and provided Owner or Engineer do not remedy such suspension or failure within that time, terminate the contract and recover from Owner payment on the same terms as provided in Paragraph 16.03.
- B. In lieu of terminating the Contract and without prejudice to any other right or remedy, if Engineer has failed to act on an Application for Payment within 30 days after it is submitted, or Owner has failed for 30 days to pay Contractor any sum finally determined to be due, Contractor may, 7 days after written notice to Owner and Engineer, stop the Work until payment is made of all such amounts due Contractor, including interest thereon. The

provisions of this paragraph are not intended to preclude Contractor from submitting a Change Proposal for an adjustment in Contract Price or Contract Times or otherwise for expenses or damage directly attributable to Contractor's stopping the Work as permitted by this paragraph.

## **ARTICLE 17—FINAL RESOLUTION OF DISPUTES**

### **17.01 *Methods and Procedures***

- A. *Disputes Subject to Final Resolution:* The following disputed matters are subject to final resolution under the provisions of this article:
1. A timely appeal of an approval in part and denial in part of a Claim, or of a denial in full, pursuant to Article 12; and
  2. Disputes between Owner and Contractor concerning the Work, or obligations under the Contract Documents, that arise after final payment has been made.
- B. *Final Resolution of Disputes:* For any dispute subject to resolution under this article, Owner or Contractor may:
1. elect in writing to invoke the dispute resolution process provided for in the Supplementary Conditions;
  2. agree with the other party to submit the dispute to another dispute resolution process; or
  3. if no dispute resolution process is provided for in the Supplementary Conditions or mutually agreed to, give written notice to the other party of the intent to submit the dispute to a court of competent jurisdiction.

## **ARTICLE 18—MISCELLANEOUS**

### **18.01 *Giving Notice***

- A. Whenever any provision of the Contract requires the giving of written notice to Owner, Engineer, or Contractor, it will be deemed to have been validly given only if delivered:
1. in person, by a commercial courier service or otherwise, to the recipient's place of business;
  2. by registered or certified mail, postage prepaid, to the recipient's place of business; or
  3. by e-mail to the recipient, with the words "Formal Notice" or similar in the e-mail's subject line.

### **18.02 *Computation of Times***

- A. When any period of time is referred to in the Contract by days, it will be computed to exclude the first and include the last day of such period. If the last day of any such period falls on a Saturday or Sunday or on a day made a legal holiday by the law of the applicable jurisdiction, such day will be omitted from the computation.

18.03 *Cumulative Remedies*

- A. The duties and obligations imposed by these General Conditions and the rights and remedies available hereunder to the parties hereto are in addition to, and are not to be construed in any way as a limitation of, any rights and remedies available to any or all of them which are otherwise imposed or available by Laws or Regulations, by special warranty or guarantee, or by other provisions of the Contract. The provisions of this paragraph will be as effective as if repeated specifically in the Contract Documents in connection with each particular duty, obligation, right, and remedy to which they apply.

18.04 *Limitation of Damages*

- A. With respect to any and all Change Proposals, Claims, disputes subject to final resolution, and other matters at issue, neither Owner nor Engineer, nor any of their officers, directors, members, partners, employees, agents, consultants, or subcontractors, shall be liable to Contractor for any claims, costs, losses, or damages sustained by Contractor on or in connection with any other project or anticipated project.

18.05 *No Waiver*

- A. A party's non-enforcement of any provision will not constitute a waiver of that provision, nor will it affect the enforceability of that provision or of the remainder of this Contract.

18.06 *Survival of Obligations*

- A. All representations, indemnifications, warranties, and guarantees made in, required by, or given in accordance with the Contract, as well as all continuing obligations indicated in the Contract, will survive final payment, completion, and acceptance of the Work or termination of the Contract or of the services of Contractor.

18.07 *Controlling Law*

- A. This Contract is to be governed by the law of the state in which the Project is located.

18.08 *Assignment of Contract*

- A. Unless expressly agreed to elsewhere in the Contract, no assignment by a party to this Contract of any rights under or interests in the Contract will be binding on the other party without the written consent of the party sought to be bound; and, specifically but without limitation, money that may become due and money that is due may not be assigned without such consent (except to the extent that the effect of this restriction may be limited by law), and unless specifically stated to the contrary in any written consent to an assignment, no assignment will release or discharge the assignor from any duty or responsibility under the Contract.

18.09 *Successors and Assigns*

- A. Owner and Contractor each binds itself, its successors, assigns, and legal representatives to the other party hereto, its successors, assigns, and legal representatives in respect to all covenants, agreements, and obligations contained in the Contract Documents.

18.10 *Headings*

- A. Article and paragraph headings are inserted for convenience only and do not constitute parts of these General Conditions.



# SUPPLEMENTARY CONDITIONS OF THE CONSTRUCTION CONTRACT

## TABLE OF CONTENTS

	Page
Article 1— Definitions and Terminology.....	1
Article 2— Preliminary Matters .....	1
Article 3— Contract Documents: Intent, Requirements, Reuse.....	5
Article 4— Commencement and Progress of the Work .....	5
Article 5— Site, Subsurface and Physical Conditions, Hazardous Environmental Conditions: noT used .....	6
Article 6— Bonds and Insurance.....	6
Article 7— Contractor’s Responsibilities .....	7
Article 8— Other Work at the Site – Not USED .....	8
Article 9— Owner’s Responsibilities .....	8
Article 10— Engineer’s Status During Construction .....	8
Article 11— Changes to the Contract .....	10
Article 12— claims .....	10
Article 13— Cost of Work; Allowances, Unit Price Work.....	10
Article 14— Tests and Inspections; Correction, Removal, or Acceptance of Defective Work.....	10
Article 15— Payments to Contractor, Set Offs; Completions; Correction Period .....	11
Article 16— Suspension of Work and Termination .....	11
Article 17— Final Resolutions of Disputes .....	11
 Exhibit A – Software Requirements for Electronic Document Exchange	

## SUPPLEMENTARY CONDITIONS OF THE CONSTRUCTION CONTRACT

These Supplementary Conditions amend or supplement EJCDC® C-700, Standard General Conditions of the Construction Contract (2018). The General Conditions remain in full force and effect except as amended.

The terms used in these Supplementary Conditions have the meanings stated in the General Conditions. Additional terms used in these Supplementary Conditions have the meanings stated below, which are applicable to both the singular and plural thereof.

The address system used in these Supplementary Conditions is the same as the address system used in the General Conditions, with the prefix "SC" added—for example, "Paragraph SC-4.05."

### Article 1—DEFINITIONS AND TERMINOLOGY

- SC-1.01.A.40 Add a new sentence to Paragraph 1.01.A.40 that is to read as follows:
- Trucking, shipping, and delivery firms, consultants, and entities performing testing or inspection retained by Contractor or any Subcontractor are considered to be Subcontractors.
- SC-1.01.A.45 Add a new sentence to Paragraph 1.01.A.45 that is to read as follows:
- Entities that rent construction equipment or machinery, but are not incorporated into the Work, are considered to be Suppliers. If such rental entity furnishes both equipment and one or more personnel to operate and maintain the equipment, such entity is a Subcontractor.
- SC-1.01 Add the following new paragraph immediately after Paragraph A.50:
51. Work Order – A document that describes the Work to be performed including location, limitations, and the type of work with based on the bid item listings in the bid form. A Work Order will typically include a map or drawing, a cost estimate, a written description of the scope of work, pertinent background information or coordination requirements, and the required timeframe for Work Order Substantial Completion. Payment allowed will be based on the bid item unit pricing and agreed upon compensation for lump sum items.
- SC-1.02.C Add the following language at the end of the sentence:
- unless otherwise noted

### Article 2—PRELIMINARY MATTERS

#### 2.02 *Copies of Documents*

- SC-2.02 Amend the first sentence of Paragraph 2.02.A. to read as follows:
- Owner shall furnish to Contractor one printed copy of the Contract Documents (including one fully signed counterpart of the Agreement), and one copy in electronic portable document format (PDF).

2.06 *Electronic Transmittals*

SC-2.06 Delete Paragraphs 2.06.B and 2.06.C in their entirety and insert the following in their place:

B. *Electronic Documents Protocol*: The parties shall conform to the following provisions in Paragraphs 2.06.B and 2.06.C, together referred to as the Electronic Documents Protocol ("EDP" or "Protocol") for exchange of electronic transmittals.

1. *Basic Requirements*

- a. To the fullest extent practical, the parties agree to and will transmit and accept Electronic Documents in an electronic or digital format using the procedures described in this Protocol. Use of the Electronic Documents and any information contained therein is subject to the requirements of this Protocol and other provisions of the Contract.
- b. The contents of the information in any Electronic Document will be the responsibility of the transmitting party.
- c. Electronic Documents as exchanged by this Protocol may be used in the same manner as the printed versions of the same documents that are exchanged using non-electronic format and methods, subject to the same governing requirements, limitations, and restrictions, set forth in the Contract Documents.
- d. Except as otherwise explicitly stated herein, the terms of this Protocol will be incorporated into any other agreement or subcontract between a party and any third party for any portion of the Work on the Project, or any Project-related services, where that third party is, either directly or indirectly, required to exchange Electronic Documents with a party or with Engineer. Nothing herein will modify the requirements of the Contract regarding communications between and among the parties and their subcontractors and consultants.
- e. When transmitting Electronic Documents, the transmitting party makes no representations as to long term compatibility, usability, or readability of the items resulting from the receiving party's use of software application packages, operating systems, or computer hardware differing from those established in this Protocol.
- f. Nothing herein negates any obligation 1) in the Contract to create, provide, or maintain an original printed record version of Drawings and Specifications, signed and sealed according to applicable Laws and Regulations; 2) to comply with any applicable Law or Regulation governing the signing and sealing of design documents or the signing and electronic transmission of any other documents; or 3) to comply with the notice requirements of Paragraph 18.01 of the General Conditions.

2. *System Infrastructure for Electronic Document Exchange*

- a. Each party will provide hardware, operating system(s) software, internet, e-mail, and large file transfer functions ("System Infrastructure") at its own cost and sufficient for complying with the EDP requirements. With the exception of minimum standards set forth in this EDP, and any explicit system requirements specified by attachment to this EDP, it is the obligation of each party to determine, for itself, its own System Infrastructure.

- 1) The maximum size of an email attachment for exchange of Electronic Documents under this EDP is **20 MB**. Attachments larger than that may be exchanged using large file transfer functions or physical media.
  - 2) Each Party assumes full and complete responsibility for any and all of its own costs, delays, deficiencies, and errors associated with converting, translating, updating, verifying, licensing, or otherwise enabling its System Infrastructure, including operating systems and software, for use with respect to this EDP.
- b. Each party is responsible for its own system operations, security, back-up, archiving, audits, printing resources, and other Information Technology ("IT") for maintaining operations of its System Infrastructure during the Project, including coordination with the party's individual(s) or entity responsible for managing its System Infrastructure and capable of addressing routine communications and other IT issues affecting the exchange of Electronic Documents.
  - c. Each party will operate and maintain industry-standard, industry-accepted, ISO-standard, commercial-grade security software and systems that are intended to protect the other party from: software viruses and other malicious software like worms, trojans, adware; data breaches; loss of confidentiality; and other threats in the transmission to or storage of information from the other parties, including transmission of Electronic Documents by physical media such as CD/DVD/flash drive/hard drive. To the extent that a party maintains and operates such security software and systems, it shall not be liable to the other party for any breach of system security.
  - d. In the case of disputes, conflicts, or modifications to the EDP required to address issues affecting System Infrastructure, the parties shall cooperatively resolve the issues; but, failing resolution, the Owner is authorized to make and require reasonable and necessary changes to the EDP to effectuate its original intent. If the changes cause additional cost or time to Contractor, not reasonably anticipated under the original EDP, Contractor may seek an adjustment in price or time under the appropriate process in the Contract.
  - e. Each party is responsible for its own back-up and archive of documents sent and received during the term of the contract under this EDP, unless this EDP establishes a Project document archive, either as part of a mandatory Project website or other communications protocol, upon which the parties may rely for document archiving during the specified term of operation of such Project document archive. Further, each party remains solely responsible for its own post-Project back-up and archive of Project documents after the term of the Contract, or after termination of the Project document archive, if one is established, for as long as required by the Contract and as each party deems necessary for its own purposes.
  - f. If a receiving party receives an obviously corrupted, damaged, or unreadable Electronic Document, the receiving party will advise the sending party of the incomplete transmission.
  - g. The parties will bring any non-conforming Electronic Documents into compliance with the EDP. The parties will attempt to complete a successful transmission of the Electronic Document or use an alternative delivery method to complete the communication.

- h. The Owner will operate a Project information management system (also referred to in this EDP as "Project Website") for use of Owner, Engineer and Contractor during the Project for exchange and storage of Project-related communications and information. Except as otherwise provided in this EDP or the General Conditions, use of the Project Website by the parties as described in this Paragraph will be mandatory for exchange of Project documents, communications, submittals, and other Project-related information. The following conditions and standards will govern use of the Project Website:
  - 1) Describe the period of time during which the Project Website will be operated and be available for reliance by the parties;
  - 2) Provide any minimum system infrastructure, software licensing and security standards for access to and use of the Project Website;
  - 3) Describe the types and extent of services to be provided at the Project Website (such as large file transfer, email, communication and document archives, etc.); and
  - 4) Include any other Project Website attributes that may be pertinent to Contractor's use of the facility and pricing of such use.

C. *Software Requirements for Electronic Document Exchange; Limitations*

- 1. Each party will acquire the software and software licenses necessary to create and transmit Electronic Documents and to read and to use any Electronic Documents received from the other party (and if relevant from third parties), using the software formats required in this section of the EDP.
  - a. Prior to using any updated version of the software required in this section for sending Electronic Documents to the other party, the originating party will first notify and receive concurrence from the other party for use of the updated version or adjust its transmission to comply with this EDP.
- 2. The parties agree not to intentionally edit, reverse engineer, decrypt, remove security or encryption features, or convert to another format for modification purposes any Electronic Document or information contained therein that was transmitted in a software data format, including Portable Document Format (PDF), intended by sender not to be modified, unless the receiving party obtains the permission of the sending party or is citing or quoting excerpts of the Electronic Document for Project purposes.
- 3. Software and data formats for exchange of Electronic Documents will conform to the requirements set forth in Exhibit A to this EDP, including software versions, if listed.

SC-2.06 Supplement Paragraph 2.06 of the General Conditions by adding the following paragraph:

D. *Requests by Contractor for Electronic Documents in Other Formats*

- 1. Release of any Electronic Document versions of the Project documents in formats other than those identified in the Electronic Documents Protocol (if any) or elsewhere in the Contract will be at the sole discretion of the Owner.
- 2. To extent determined by Owner, in its sole discretion, to be prudent and necessary, release of Electronic Documents versions of Project documents and other Project

information requested by Contractor (“Request”) in formats other than those identified in the Electronic Documents Protocol (if any) or elsewhere in the Contract will be subject to the provisions of the Owner’s response to the Request, and to the following conditions to which Contractor agrees:

- a. The content included in the Electronic Documents created by Engineer and covered by the Request was prepared by Engineer as an internal working document for Engineer’s purposes solely, and is being provided to Contractor on an “AS IS” basis without any warranties of any kind, including, but not limited to any implied warranties of fitness for any purpose. As such, Contractor is advised and acknowledges that the content may not be suitable for Contractor’s application or may require substantial modification and independent verification by Contractor. The content may include limited resolution of models, not-to-scale schematic representations and symbols, use of notes to convey design concepts in lieu of accurate graphics, approximations, graphical simplifications, undocumented intermediate revisions, and other devices that may affect subsequent reuse.
  - b. Electronic Documents containing text, graphics, metadata, or other types of data that are provided by Engineer to Contractor under the request are only for convenience of Contractor. Any conclusion or information obtained or derived from such data will be at the Contractor’s sole risk and the Contractor waives any claims against Engineer or Owner arising from use of data in Electronic Documents covered by the Request.
  - c. Contractor shall indemnify and hold harmless Owner and Engineer and their subconsultants from all claims, damages, losses, and expenses, including attorneys’ fees and defense costs arising out of or resulting from Contractor’s use, adaptation, or distribution of any Electronic Documents provided under the Request.
  - d. Contractor agrees not to sell, copy, transfer, forward, give away or otherwise distribute this information (in source or modified file format) to any third party without the direct written authorization of Engineer, unless such distribution is specifically identified in the Request and is limited to Contractor’s subcontractors. Contractor warrants that subsequent use by Contractor’s subcontractors complies with all terms of the Contract Documents and Owner’s response to Request.
  - e. Contractor agrees to execute ENGINEER’s standard agreement for release of electronic files (copy attached to Specification Section 01 n78 39. Record Documents) and shall abide by the provisions of such agreement for release of electronic files.
3. Not Used.

### Article 3—**CONTRACT DOCUMENTS: INTENT, REQUIREMENTS, REUSE**

No suggested Supplementary Conditions in this Article.

### Article 4—**COMMENCEMENT AND PROGRESS OF THE WORK**

#### 4.01 Commencement of Contract Times; Notice to Proceed

SC-4.01 Amend the second sentence to read as follows:

Delete "60<sup>th</sup> day" and substitute "46<sup>th</sup> day"

SC-4.05 Amend Paragraph 4.05.D by adding the following subparagraphs:

4. *Weather-Related Delays*

- a. If "abnormal weather conditions" as set forth in Paragraph 4.05.C.2 of the General Conditions are the basis for a request for an equitable adjustment in the Contract Times, such request must be documented by data substantiating each of the following: 1) that weather conditions were abnormal for the period of time in which the delay occurred, 2) that such weather conditions could not have been reasonably anticipated, and 3) that such weather conditions had an adverse effect on the Work as scheduled.
- b. The existence of abnormal weather conditions will be determined in accordance with the following:
  - 1.) A documentable level of precipitation that impacts the specific tasks required at that time. Documentation must be submitted of the described impact on the tasks and the amount of precipitation. Acceptable documentation of precipitation amounts includes records from the National Weather Service at the Buffalo International Airport, a picture of a precipitation measurement device (with proof of location, date and time), or records from another agreed upon source.
  - 2.) A documentable temperature that impacts the specific tasks required at that time. Documentation must be submitted of the described impact on the tasks and the temperature. Acceptable documentation of temperature includes records from the National Weather Service at the Buffalo International Airport, a picture of a weather app (that indicates location, date and time), or records from another agreed upon source.
- c. The time allocated in the Contract has accounted for a reasonable amount of "abnormal weather conditions" delays. Contractor shall not be entitled to an adjustment in Contract Time if the stated condition, or the number of days of the stated condition, is within 10% of the average for that condition in that month (as determined by averaging the data for the last 10 years from the National Weather Service at the Buffalo International Airport or other agreed upon source).

**Article 5—SITE, SUBSURFACE AND PHYSICAL CONDITIONS, HAZARDOUS ENVIRONMENTAL CONDITIONS**

No suggested Supplementary Conditions in this Article.

**Article 6—BONDS AND INSURANCE**

No suggested Supplementary Conditions in this Article.



Article 7—**CONTRACTOR’S RESPONSIBILITIES**

7.02 *Supervision and Superintendence*

SC-7.02 Amend Paragraph 7.02.B of the General Conditions by adding the following sentence:

Unless the Owner otherwise agrees in writing, the superintendent will be Contractor’s representative at the Site and shall have authority to act on behalf of Contractor. All communications given to or received from the superintendent shall be binding on Contractor.

7.03 *Labor; Working Hours*

SC-7.03 Add the following new subparagraphs immediately after Paragraph 7.03.C:

1. Regular working hours will be determined at the pre-construction conference and are typically 7AM to 3 PM.
2. Owner’s legal holidays are legal holidays include New Year’s Day, Martin Luther King Jr Day, President’s Day, Good Friday, Memorial Day, Juneteenth National Independence Day, Independence Day, Labor Day, Veteran’s Day, Thanksgiving, and Christmas.

SC-7.03 Amend the first and second sentences of Paragraph 7.03.C to state “...all Work must be performed during regular working hours, **Monday** through **Friday**. Contractor will not perform Work on a **Saturday, Sunday**, or any legal holiday, unless directed in the Work Order or otherwise authorized in writing by the Engineer.”

SC-7.03 Add the following sentence at the end of Paragraph 7.03.C:

1. Applications to perform Work outside regular working hours or on Saturdays, Sundays, or legal holidays should be made using NYS Department of Labor PW-30, “Application for Dispensation of Hours”, which can be found at [www.labor.ny.gov](http://www.labor.ny.gov).

SC-7.03 Add the following new paragraph immediately after Paragraph 7.03.C:

- D. Contractor shall be responsible for the cost of any overtime pay or other expense incurred by the Owner for Engineer’s services (including those of the Resident Project Representative, if any), Owner’s representative, and construction observation services, occasioned by the performance of Work on Saturday, Sunday, any legal holiday, or as overtime on any regular work day. If Contractor is responsible but does not pay, or if the parties are unable to agree as to the amount owed, then Owner may impose a reasonable set-off against payments due under Article 15.

7.07 *Concerning Subcontractors and Suppliers*

SC-7.07 Add the following new subparagraph immediately after Paragraph 7.07.A :

1. Owner reserves the right to limit the amount of Work subcontracted to a maximum of 50 percent of the Contract Price.

7.10 *Taxes*

SC-7.10 Delete Paragraph 7.10.A in its entirety and insert the following in its place:

- A. Owner is exempt from payment of sales and compensating use taxes of the State of New York and of cities and counties thereof on all materials to be incorporated into the Work.

1. Owner will furnish the required certificates of tax exemption to Contractor for use in the purchase of supplies and materials to be incorporated into the Work.
2. Owner's exemption does not apply to construction tools, machinery, equipment, or other property purchased by or leased by Contractor, or to supplies or materials not incorporated into the Work.

7.13 *Safety and Protection*

SC-7.13 Amend the second sentence of Paragraph 7.13.G by deleting the words "...the Supplementary Conditions or Specifications." and replace with the words Specification Section 01 35 23, Owner Safety Requirements".

7.14 *Hazard Communication Programs*

SC-7.14 Add the following new paragraph immediately after Paragraph 7.14.A:

B. Contractor shall provide a centralized location for the maintenance of the safety data sheets or other hazard communication information required to be made available by any employer on the Site. Location of the safety data sheets or other hazard communication information shall be readily accessible to the employees of all employers on the Site.

**Article 8—OTHER WORK AT THE SITE – NOT USED**

**Article 9—OWNER'S RESPONSIBILITIES**

9.01 *Communications to Contractor*

Add the following new paragraph immediately after Paragraph 9.01.A:

1. Verbal instructions will be confirmed with written directives

9.12 *Safety Programs*

SC-9.12.B Delete Paragraph 9.12.B in its entirety and insert the following in its place:

B. The Owner's safety program is in the Specifications

9.13 *Owner's Site Representative*

SC-9.13 Add the following new paragraph immediately after Paragraph 9.12 of the General Conditions:

**Article 10—ENGINEER'S STATUS DURING CONSTRUCTION**

10.03 *Resident Project Representative*

SC-10.03 Add the following new paragraphs immediately after Paragraph 10.03.B:

- C. The Resident Project Representative (RPR) will be Engineer's representative at the Site. RPR's dealings in matters pertaining to the Work in general will be with Engineer and Contractor. RPR's dealings with Subcontractors will only be through or with the full knowledge or approval of Contractor. The RPR will:

1. *Conferences and Meetings:* Attend meetings with Contractor, such as preconstruction conferences, progress meetings, job conferences, and other Project-related meetings (but not including Contractor's safety meetings), and as appropriate prepare and circulate copies of minutes thereof.
  2. *Safety Compliance:* Comply with Site safety programs, as they apply to RPR, and if required to do so by such safety programs, receive safety training specifically related to RPR's own personal safety while at the Site.
  3. *Liaison*
    - a. Serve as Engineer's liaison with Contractor. Working principally through Contractor's authorized representative or designee, assist in providing information regarding the provisions and intent of the Contract Documents.
    - b. Assist Engineer in serving as Owner's liaison with Contractor when Contractor's operations affect Owner's on-Site operations.
    - c. Assist in obtaining from Owner additional details or information, when required for Contractor's proper execution of the Work.
  4. *Review of Work; Defective Work*
    - a. Conduct on-Site observations of the Work to assist Engineer in determining, to the extent set forth in Paragraph 10.02, if the Work is in general proceeding in accordance with the Contract Documents.
    - b. Observe whether any Work in place appears to be defective.
    - c. Observe whether any Work in place should be uncovered for observation, or requires special testing, inspection or approval.
  5. *Inspections and Tests*
    - a. Observe Contractor-arranged inspections required by Laws and Regulations, including but not limited to those performed by public or other agencies having jurisdiction over the Work.
    - b. Accompany visiting inspectors representing public or other agencies having jurisdiction over the Work.
  6. *Payment Requests:* Review Applications for Payment with Contractor.
  7. *Completion*
    - a. Participate in Engineer's visits regarding Substantial Completion.
    - b. Assist in the preparation of a punch list of items to be completed or corrected.
    - c. Participate in Engineer's visit to the Site in the company of Owner and Contractor regarding completion of the Work, and prepare a final punch list of items to be completed or corrected by Contractor.
    - d. Observe whether items on the final punch list have been completed or corrected.
- D. The RPR will not:
1. Authorize any deviation from the Contract Documents or substitution of materials or equipment (including "or-equal" items).

2. Exceed limitations of Engineer's authority as set forth in the Contract Documents.
3. Undertake any of the responsibilities of Contractor, Subcontractors, or Suppliers.
4. Advise on, issue directions relative to, or assume control over any aspect of the means, methods, techniques, sequences or procedures of construction.
5. Advise on, issue directions regarding, or assume control over security or safety practices, precautions, and programs in connection with the activities or operations of Owner or Contractor.
6. Participate in specialized field or laboratory tests or inspections conducted off-site by others except as specifically authorized by Engineer.
7. Authorize Owner to occupy the Project in whole or in part.

**Article 11—CHANGES TO THE CONTRACT**

No suggested Supplementary Conditions in this Article.

**Article 12—CLAIMS**

No suggested Supplementary Conditions in this Article

**Article 13—COST OF WORK; ALLOWANCES, UNIT PRICE WORK**

13.01 Cost of the Work

SC-13.01 Supplement Paragraph 13.01.B.5.c.(2) by adding the following sentence:

The equipment rental rate book that governs the included costs for the rental of machinery and equipment owned by Contractor (or a related entity) under the Cost of the Work provisions of this Contract is the most current edition of Rental Rate Blue Book For Construction Equipment.

SC-13.01 Supplement Paragraph 13.01.C.2 by adding the following definition of small tools and hand tools:

- a. For purposes of this paragraph, "small tools and hand tools" means any tool or equipment whose current price if it were purchased new at retail would be less than \$750.

**Article 14—TESTS AND INSPECTIONS; CORRECTION, REMOVAL, OR ACCEPTANCE OF DEFECTIVE WORK**

No suggested Supplementary Conditions in this Article.

**Article 15—PAYMENTS TO CONTRACTOR, SET OFFS; COMPLETIONS; CORRECTION PERIOD**

15.01 *Progress Payments*

SC-15.01.B.1 Delete Paragraph 15.01.B.1 and insert the following in its place:

1. Contractor shall submit to Engineer for review an Application for Payment filled out and signed by Contractor covering the Work completed as of the last day of the preceding month and accompanied by such supporting documentation as is required by the Contract Documents.

SC-15.01.D.1 Delete the word "Ten" and insert "thirty".

15.03 *Substantial Completion*

SC-15.03 Add the following new subparagraph to Paragraph 15.03.B:

1. If some or all of the Work has been determined not to be at a point of Substantial Completion and will require reinspection or retesting by Engineer, the cost of such reinspection or retesting, including the cost of time, travel and living expenses, will be paid by Contractor to Owner. If Contractor does not pay, or the parties are unable to agree as to the amount owed, then Owner may impose a reasonable set-off against payments due under this Article 15.

SC-15.06 Add the following language immediately following Paragraph 15.06.A.2.e:

- f. signed release from any property owner's that contractor leased land from

**Article 16—SUSPENSION OF WORK AND TERMINATION**

No suggested Supplementary Conditions in this Article.

**Article 17—FINAL RESOLUTIONS OF DISPUTES**

17.02 *Attorneys' Fees*

SC-17.02 Add the following new paragraph immediately after Paragraph 17.01.

17.02 *Attorneys' Fees*

- A. For any matter subject to final resolution under this Article, the prevailing party shall be entitled to an award of its attorneys' fees incurred in the final resolution proceedings, in an equitable amount to be determined in the discretion of the court, arbitrator, arbitration panel, or other arbiter of the matter subject to final resolution, taking into account the parties' initial demand or defense positions in comparison with the final result.

**EXHIBIT A—SOFTWARE REQUIREMENTS FOR ELECTRONIC DOCUMENT EXCHANGE**

Item	Electronic Documents	Transmittal Means	Data Format	Note (1)
a.1	General communications, transmittal covers, meeting notices and responses to general information requests for which there is no specific prescribed form.	Email	Email	
a.2	Meeting agendas, meeting minutes, RFI's and responses to RFI's, and Contract forms.	Email w/ Attachment	PDF	(2)
a.3	Contactors Submittals (Shop Drawings, "or equal" requests, substitution requests, documentation accompanying Sample submittals and other submittals) to Owner and Engineer, and Owner's and Engineer's responses to Contractor's Submittals, Shop Drawings, correspondence, and Applications for Payment.	Email w/ Attachment or LFE	PDF	
a.4	Correspondence; milestone and final version Submittals of reports, layouts, Drawings, maps, calculations and spreadsheets, Specifications, Drawings and other Submittals from Contractor to Owner or Engineer and for responses from Engineer and Owner to Contractor regarding Submittals.	Email w/ Attachment or LFE	PDF	
a.5	Layouts and drawings to be submitted to Owner for future use and modification.	Email w/ Attachment or LFE	DWG	
a.6	Correspondence, reports and Specifications to be submitted to Owner for future word processing use and modification.	Email w/ Attachment or LFE	DOC	
a.7	Spreadsheets and data to be submitted to Owner for future data processing use and modification.	Email w/ Attachment or LFE	EXC	
a.8	Database files and data to be submitted to Owner for future data processing use and modification.	Email w/ Attachment or LFE	DB	
<b>Notes</b>				
(1)	All exchanges and uses of transmitted data are subject to the appropriate provisions of Contract Documents.			
(2)	Transmittal of written notices is governed by Paragraph 18.01 of the General Conditions.			
<b>Key</b>				
Email	Standard Email formats (.htm, .rtf, or .txt). Do not use stationery formatting or other features that impair legibility of content on screen or in printed copies			
LFE	Agreed upon Large File Exchange method (FTP, CD, DVD, hard drive)			
PDF	Portable Document Format readable by Adobe® Acrobat Reader			
DWG	Autodesk® AutoCAD .dwg format			
DOC	Microsoft® Word .docx format			
EXC	Microsoft® Excel .xls or .xml format			
DB	Microsoft® Access .mdb format			

## SECTION 00 73 36

### EQUAL EMPLOYMENT OPPORTUNITY REQUIREMENTS

This Section details equal employment opportunity requirements for the Project. This Section is part of the Contract Documents.

	Page
Article 1— County of Erie E.E.O Affirmative Action Plan.....	2
Article 2— Erie County Executive Order #13 Pay Equity Certification on County Contracts.....	4
Article 3— RULES AND REGULATIONS.....	7
Article 4— EQUAL EMPLOYMENT OPPORTUNITY FORMS.....	7

FORMS:

1. Erie County Equal Pay Certification - **(SUBMIT WITH BID -Included in Invitation to Bid - Exhibit "EP")**





**ARTICLE 1—COUNTY OF ERIE E.E.O AFFIRMATIVE ACTION PLAN**

COUNTY OF ERIE E.E.O  
AFFIRMATIVE ACTION PLAN

EQUAL EMPLOYMENT OPPORTUNITY

In the performance of work under Erie County Contracts or any subcontract, no Contractor, subcontractor, nor any person acting on behalf of such Contractor, or subcontractor, in their employment practices, shall by reason of race, color, national origin, sex, age, religion, marital status, or disability discriminate against any citizen of the State of New York who is qualified and available to perform the work to which the employment relates. Reference Title VI of the Civil Rights Act of 1964 (43 USC 200d).

Executive Order 11246, 30 Federal Regulation 12319 (1965) (Equal Opportunity Clause)

During the performance of Erie County contracts, the Contractor agrees:

A. The Contractor will not discriminate against any employee or applicant for employment because of race, color, national origin, sex, age, relation, marital status, or disability. The Contractor will take affirmative action to ensure the applicants are employed and employees are treated during employment, without regard to their race, color, national origin, sex, age, religion, marital status or disability. Such action shall include, but not be limited to the following: employment, upgrading, demotion or transfer; recruitment or recruitment advertising; layoff or termination; rates of pay or other forms of compensation; and selection for training, including apprenticeship.

B. The Contractor agrees to appoint an Equal Employment Opportunity (EEO) officer whose function will be to assure that said Contractor participates fully and effectively in the County or Erie Affirmative Action Program in compliance with the requirements of the County of Erie Contract.

C. The Contractor agrees to post in conspicuous places, available to employees and applicants for employment, notices to be provided by the EEO officer setting forth the provisions of this non-discrimination clause.

D. The Contractor will, in all solicitations or advertisements for employees placed by or on behalf of the Contractor, state that all qualified applicants will receive consideration for employment without regard to race, color, national origin, sex, age, religion, marital status, or disability.

E. The Contractor will send to each labor union or representative of workers with which he has a collective bargaining agreement or other contract or understanding, a notice to be provided by the organization EEO officer, advising the labor union or workers' representative of the Contractor's commitment under Executive Order No. 11246 on September 24, 1965, and shall post copies of the notice in conspicuous places available to employees and applicants for employment.

F. The Contractor will file, by the fifteenth day of each month with the EEO Office and the Contracting Agency, a monthly manpower utilization report of his work force on the Erie County project for the preceding month, broken down by racial groups, craft status, and job classification and including (a) the number of minority workers he has secured and (b) the type of On-the-Job Training he has provided on the Erie County project, the classification of said minority participants (apprentices, journeymen, and trainees), the specific crafts in which they have received training, and the number of hours they have worked.



SUBMIT WITH BID

G. The Contractor will comply with all provisions of Executive Order No. 11246 of September 24, 1965 and all relevant rules, regulations, and orders of an Erie County Contract and the Erie County Affirmative Action Program.

H. In the event the Contractor's non-compliance with the nondiscrimination clauses of an Erie County Contract or with any such rules, regulations, or orders that contract may be cancelled, terminated, or suspended in whole or in part and the Contractor may be declared ineligible for further Erie County contracts in accordance with the procedures authorized in Executive Order No. 11246 or as otherwise provided by law.

I. The Contractor will include the provisions of paragraphs A through I in every subcontract or purchase order unless specifically exempted by the rules, regulations, or orders, of an Erie County contractual agreement, so that such provisions will be binding upon each subcontractor or vendor.

The Contractor will take such action with respect to any subcontractor or purchase order as the Contracting Agency may direct as a means of enforcing such provisions including sanctions for non-compliance; provided, however, that in the event that Contractor becomes involved in, or is threatened with litigation with any subcontractor or vendor as a result of such direction by the Contracting Agency, the Contractor may request the County of Erie to enter into such litigations to protect the interests of the County of Erie.

MONITORING:

The EEO Office has the responsibility of administering the Monitoring Program for the County of Erie and its Affirmative Action Program. During the monitoring of an organization, the EEO Office shall receive the full cooperation of the Contracting Agency in dealing with organizations needing remedial actions.

The objective of the County of Erie's Monitoring Program is a systematic review, by the EEO Office, of the Contractor's performance in meeting the goals of minority utilization at each level of his work force. There will be two basic results from the County of Erie's monitoring process:

1. Acceptable achievement or progress, according to this program for construction contracts on County of Erie projects, toward the County of Erie's goal of 13.2 minority manpower utilization, and in addition, the County of Erie's goal for the utilization of women in the area of construction shall be in accordance with the U.S. Department of Labor's goals and timetable, with the contract remaining intact.

U.S. Department of Labor – Office of Federal Contract Compliance

GOALS FOR WOMEN IN THE AREA OF CONSTRUCTION:

Goals and Timetables

From April 1, 1978 until March 31, 1979 . . . . .	3.1%
From April 1, 1979 until March 31, 1980 . . . . .	5.1%
From April 1, 1980 . . . . .	6.9%

2. Insufficient progress toward goals according to the program; if an organization is found to be unwilling to correct deficiencies after a recommended non-compliance investigation, the County of Erie may:

A. Summon the Contractor to a hearing.



SUBMIT WITH BID

- B. Withhold progress payments in part or in full.
- C. Cancel the Contract.
- D. Bar the award of future contracts until the Contractor can demonstrate that he will comply.

The County of Erie's Monitoring Program will consist of both Off-Site and On-Site monitoring.

Off-Site monitoring program shall consist of Monthly Employment Utilization reports, submitted via LCPTracker. Due to the regular turnover of the work force of a construction Contractor and because of Federal Compliance reporting requirements, all Contractors and subcontractors must submit these monthly reports to the Erie County EEO Office and the Contracting Agency. These reports will state an employee's EEO identification trade, classification, hours worked, and the percentage of completion for each County of Erie project for each reporting month.

On-Site monitoring, for the purpose of verifying these monthly reports, will be dependent on but not limited to:

1. The compliance status of each Contractor for each County of Erie construction project.
2. Length of the contract, subcontract, or grant and its percentage of completion.
3. Size of the labor force of the organization.
4. Degree of employment opportunity the County of Erie contract, subcontract, or grant will offer to minority workers.
5. Past record of affirmative action achievement of the organization.
6. Past record of affirmative action compliance performance under the EEO Office.

The EEO Office will have an ongoing Master File, dealing with each Contractor or subcontractor for each County of Erie construction project participated in for reference of the past performance of each Contractor.

In the event any deficiencies are found during an Off-Site or On-Site analysis, organization officials shall receive a summary of these deficiencies and the audits made for each reporting month. Any violations found will be fully explained and discussed with the Contractor or subcontractor. During discussions with the EEO Office and the Contracting Agency, alternative solutions to particular problems will be explored. At this time, attempts will be made to obtain the Contractor's agreements to take action by specified dates and a duplicate copy of the agreement will be sent to the Contractor or subcontractor.

**ARTICLE 2—ERIE COUNTY EXECUTIVE ORDER #13 PAY EQUITY CERTIFICATION ON COUNTY CONTRACTS**

Bound on the following pages



## COUNTY OF ERIE

**MARK C. POLONCARZ**

County Executive

### Executive Order #13 Pay Equity Certification on County Contracts

**WHEREAS**, federal law, including the Equal Pay Act of 1963, Title VII of the Civil Rights Act of 1964 and Federal Executive Order 11246 of September 24, 1965 (Equal Employment Opportunity) (together "Federal Equal Pay Law"), requires that men and women in the same workplace be given equal pay for equal work; and

**WHEREAS**, Section 194 of New York State Labor Law ("NYS Equal Pay Law") prohibits compensating men and women differently for the same work; and

**WHEREAS**, on average, a full-time working woman in New York State earns just 85 cents for every dollar that a man earns and the pay gap is even greater for African-American and Latina women; and

**WHEREAS**, females make up nearly fifty-two percent of Erie County's population; and

**WHEREAS**, women make up nearly half of the U.S. labor force and are a growing number of breadwinners in their families; and

**WHEREAS**, this pay differential shortchanges women and their families by thousands of dollars a year, and potentially hundreds of thousands of dollars over a lifetime, presenting a lifelong threat to those families' economic security and reducing their earnings through Social Security and other post retirement plans, and

**WHEREAS**, poverty is recognized as a leading cause of or contributing factor to many social problems, including but not limited to substance abuse, domestic violence, child abuse, improper nutrition, obesity, improper health care and criminal conduct; and

**WHEREAS**, the impact of pay differentials is exacerbated as workers age, causing underpaid workers to disproportionately rely upon various forms of public support in their retirement years; and

**WHEREAS**, pay inequity can significantly impact the County, necessitating the provision of various public subsidies for low income residents and leading to the lack of receipt of income by women residents which would be spent in our local economy; and



WHEREAS, through the enforcement of current state and federal laws that ban unequal pay for equal work, Erie County can help ameliorate the many negative consequences of pay inequality, thereby improving the lives of those who might otherwise be underpaid, strengthening families and protecting children, and reducing the demand for public services, all positively impacting county, state and federal budgets.

NOW, THEREFORE, I MARK C. POLONCARZ, Erie County Executive, by virtue of the authority vested in me by the Erie County Charter § 302, do hereby order as follows:

1. It is ordered that on and after January 1, 2015, all Erie County offices, departments and administrative units, including but not limited to the Division of Purchase, fully implement a requirement in all bids, requests for proposals and other contract solicitations that the contractor submit an Erie County Equal Pay Certification which certifies the contractor's compliance with Federal Equal Pay Law and New York State Equal Pay Law (together, the "Equal Pay Laws"). Such certification shall be required prior to execution of the contract; and it is,
2. Further ordered that such certification shall include a representation by the contractor that it has not been the subject of an adverse finding under the Equal Pay Laws within the previous five years and shall include disclosure of any currently pending claims against the contractor; and it is,
3. Further ordered that violation of any provision of the Equal Pay Laws during the effective period of such a contract or the filing of a false or misleading Erie County Equal Pay Certificate may constitute grounds for immediate termination of such a contract; and it is,
4. Further ordered that violation of any provision of the Equal Pay Laws during the effective period of such a contract or the filing of a false or misleading Erie County Equal Pay Certificate may constitute grounds for determining a bidder or responder is not qualified to participate in future County contracts; and it is,
5. Further ordered that the Law Department prepare an Erie County Equal Pay Certification for use by Erie County offices, departments and administrative units and assure compliance with this Executive Order in the contract approval process; and it is,
6. Further ordered that the County Division of Equal Employment Opportunity ("EEO") establish a procedure for compliance monitoring and periodic auditing of certification records; and it is,

GIVEN, under my hand and the Privy Seal of the County of Erie in the City of Buffalo this 6<sup>th</sup> day of November, in the year two thousand fourteen.

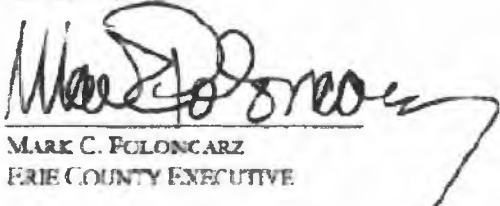

COUNTY OF ERIE

By:   
MARK C. POLONCARZ  
ERIE COUNTY EXECUTIVE

SUBMIT WITH BID

**ARTICLE 3—RULES AND REGULATIONS**

The Contractor shall comply with Erie County Executive Order 13 (2014) and agrees to complete the Certificate collectively attached in the Proposal Section and made a part hereof. The Contractor shall make such records available, upon request, to the County's Division of Equal Employment Opportunity for review. The County shall have the right, upon reasonable notice and at reasonable times, to inspect the books and records of the Contractor, its offices and facilities, for the purpose of verifying information supplied in the Erie County Equal Pay Certification and for any other purpose reasonably related to confirming the Agency's compliance with Erie County Executive Order 13 (2014). Notwithstanding the termination provisions contained herein, violation of the provisions of Executive Order 13 (2014), may constitute grounds for the immediate termination of this Agreement and may constitute grounds for determining that the Contractor is not qualified to participate in future County contracts.

**ARTICLE 4—EQUAL EMPLOYMENT OPPORTUNITY FORMS**

Included in the Invitation to Bid Exhibit "EP", the following which are part of the Contract Documents:

1. Erie County Equal Pay Certification (SUBMIT WITH BID)

## SECTION 00 73 38

### APPRENTICESHIP REQUIREMENTS

This Section details apprenticeship requirements for the Project. This Section is part of the Contract Documents.

	Page
Article 1 – Erie County Local Law No. 3 – 2018.....	2
Article 2 – Local Law No. 3 – 2018 Rules and Regulations.....	6
Article 3 – Local Law No. 3 – 2018 Forms.....	8

**FORMS:**

1. New York State Certified Apprenticeship Training Program Certification (PRINT AND SUBMIT WITH BID)
2. Apprenticeship Utilization Certification for Final Payment

**ARTICLE 1 – ERIE COUNTY LOCAL LAW INTRO NO. 3 – 2018**

**COUNTY OF ERIE  
LOCAL LAW INTRO NO. 3 - 2018**

A LOCAL LAW in relation to a requirement for New York State Certified Worker Training Programs by contractors and subcontractors under construction contracts, as defined herein, with the County of Erie.

**BE IT ENACTED BY THE ERIE COUNTY LEGISLATURE AS FOLLOWS:**

Section 1. Legislative Intent.

The Erie County Legislature hereby finds, declares and determines that:

- A. New York Labor Law Section 816-b specifically authorizes this Local Law.
- B. There has been a long and productive history of partnership between labor and management in the training of workers in New York State.
- C. New York State Certified Worker Training Programs are valuable educational and training tools for the local workforce by reducing reliance on out-of-area labor for construction projects.
- D. New York State Certified Worker Training Programs provide opportunities to residents in this area through training and education for skilled jobs.
- E. These skilled jobs allow us to reinvest our taxpayer dollars spent on local construction projects so that local workers and local tax dollars remain within the local community.
- F. It would be valuable to encourage labor and business/industry to participate in New York State Certified Worker Training Programs to meet the increased need for trade persons while providing residents the means to earn a better living and fostering the local and regional economies.
- G. It is valuable for local government to encourage broad participation in such New York State Certified Worker Training Programs by the residents of Erie County and to foster the equal opportunity of men and women of all races and backgrounds to participate in order to enhance workforce development and diversification, and to prevent exclusionary practices which have historically excluded women and minorities.
- H. The New York State Department of Labor sets objective standards and provides oversight for New York State Certified Worker Training Programs. These Programs are important because they require on-the-job training and classroom training, and provide objective industry standards. In effect these programs lead to a standardized, cost effective and skilled local workforce.
- I. Nothing in this Local Law should be read to abrogate the duty of Erie County with respect to its MBE/WBE requirements.

Section 2. Short Title.

This Local Law shall be known as "The Erie County Workforce Development and Diversification New York State Certified Worker Training Program."

Section 3. Definitions.

A. "New York State Certified Worker Training Program" shall mean: a state registered and regulated apprenticeship program through the New York State Department of Labor that has been approved by the New York State Commissioner of Labor in accordance with Article 23 of the New York Labor Law, that includes the following standards:

- i. An organized, written plan in place that embodies the terms and conditions of employment, and the training and supervision of one or more workers;
- ii. A schedule of wages to be paid to the worker consistent with the skills required and approved by the New York State Department of Labor;
- iii. Equal opportunity and affirmative action plans;
- iv. Workforce development and diversification goals to ensure that the contractor will diligently work toward a minority workforce goal of 30% minority and female participation combined in project personnel including trades people, trainees, journeymen, apprentices and supervisory staff;
- v. A minimum of ten percent (10%) of the total construction workers. Trades people, trainees, journeymen, and apprentices employed at any given time on a particular project by any and all contractors or subcontractors must be consist of persons participating in a New York State Certified Worker Training Program.
- vi. In all cases, such Certified Apprenticeship Training Program must be specific to the type and scope of work which is being performed and must have a graduation rate of at least thirty percent (30%) as determined by the New York State Department of Labor.

B. "Commissioner" shall mean the Commissioner of the Erie County Department of Public Works.

C. "Construction contract" shall mean projects with a value in excess of \$250,000 where Erie County is a direct or indirect party to the contract which includes more than an incidental amount of construction type activity intended to benefit the public, including all work which is necessary, incidental or connected with the execution of the contract which is performed by construction workers. A public entity need not be party to the construction contract. A construction contract includes: projects that Erie County funds directly, projects that Erie County funds indirectly by providing funds to a separate entity to perform the construction type activity; privately financed construction projects specifically built with the intent of leasing them to any Department of Erie County government; and construction projects built under Erie County's direction and later paid for with Erie County funds.

D. "Construction subcontract" shall mean any subcontract between a contractor who has a construction contract as defined in Section 3, subdivision C above.

E. "Contractor" or "subcontractor" shall mean a contractor or subcontractor that directly employs construction workers, as defined below, under a construction contract or construction subcontract, as defined herein, for which a New York State Certified Worker Training Program is required.

F. "Construction worker" shall mean an individual directly involved in the construction, reconstruction, improvement, rehabilitation, installation, alteration, renovation, demolition or otherwise providing for any building, facility, roads, highways, bridges, or physical structure of any kind, but does not include professional services employees or those construction workers for which a New York State Certified Worker Training Program does not exist.

#### Section 4. Requirements.

A. Any contractor, prior to entering into a construction contract as set forth in section 3 (C) above, or any subcontractor entering into a construction subcontract with a contractor who has a construction contract with the County of Erie is required to have in place and provide written proof of same at the time of bid a New York State Certified Worker Training Program, either internally to the contractor or subcontractor and/or through an organization servicing several contractors or subcontractors, appropriate for the type and scope of work to be performed.

B. Any contractor or subcontractor, as defined herein, shall strive to meet the minimum workforce development and diversification goals set forth in section 3(A) (iv) above. Such contractors and/or subcontractors shall provide the Commissioner or designated compliance officer with the following:

i. A monthly workforce census and such other employment and/or payroll records necessary to verify an attempt to achieve the workforce development and diversification goals set forth in Section 3(A)(iv) above.

ii. Access to and cooperation with the project compliance officer to review records on-site and/or at worksite premises to validate attempts to achieve the workforce development and diversification goals set forth in Section 3(A)(iv) above.

iii. With bid submission, a statement committing to providing apprenticeship training opportunities to workers, as well as details of workforce diversification recruiting program directed at attracting candidates to fill positions to meet the minimum workforce development and diversification goals set forth in Section 3(A)(iv) above.

#### Section 5. Rules & Regulations.

As of the date this Local Law becomes effective, the Commissioner of the Erie County Department of Public Works shall promulgate such rules and regulations that are lawful, necessary and appropriate to implement, enforce or otherwise carry out the purposes of this Local Law, provided that the Legislature, by simple majority, has not voted to disapprove such rule or regulation within sixty (60) days from the Commissioner's written notice to the Legislature that such rule or regulation has been promulgated.

#### Section 6. Equal Employment Monitoring.

There shall be an Independent Monitor to report on the compliance of each County contractor and subcontractor with this Local Law's workforce development and diversification goals. The Commissioner of DPW shall develop regulations that provide for the compensation of the Independent Monitor.

The Monitor shall monitor and review every facet of construction to report what percentage of the goals that are established for minority and female participation are met or exceeded. The Monitor shall report to the Equal Employment Opportunity Office on the compliance of each contractor and subcontractor with the workforce development and diversification goals.

The Monitor shall file monthly reports with the Equal Employment Opportunity Office regarding the actual workforce development and diversification goals, including reporting all instances of non-compliance; make appropriate recommendations to the Equal Employment Opportunity Office when non-compliance is evident with supportive documentation; develop a database of the workforce of each contractor and

subcontractor to provide a visual format of each contractor's workforce, both monthly and year-to-date cumulative totals on each construction contract.

#### Section 7. Compliance.

The Director of Erie County Division of Equal Employment shall ensure that all contractors and subcontractors entering into a construction contract as it is defined herein, maintain records which prove that each construction worker as it is defined herein, signs in and out at the beginning and end of each day, listing next to his or her name his or her craft, and status as journeyman or apprentice, if applicable.

#### Section 8. Penalties.

Violation of any provision of this Local Law shall constitute cause, grounds or other legal justification for termination of any contractual agreement with any contractor or subcontractor engaged in a construction contract or construction subcontract with the County, in accordance with County and state laws, rules and regulations governing the termination of such contractual agreements.

#### Section 9. Severability.

If any clause, sentence, paragraph, subdivision, section or part of this Local Law or the application thereof, to any person, individual, corporation, firm, partnership, entity or circumstance, shall be adjudged by any court of competent jurisdiction to be invalid or unconstitutional such order of judgment shall not affect, impair, or invalidate the remainder thereof, but shall be confined in its operation to the clause, sentence, paragraph, subdivision, section or part of this Local Law or in its application to the person, individual, corporation, firm, partnership, entity, or circumstance directly involved in the controversy in which such judgment or order shall be rendered.

#### Section 10. Applicability.

This Local Law shall apply to construction contracts advertised for bids on or after the effective date with the following condition:

Apprenticeship agreements currently in place as of the effective date of this Local Law which are still in probationary status or apprenticeship agreements which were in probationary status during the period preceding the specific trade's program length as set forth in the New York State Prevailing Wage Schedule, shall be exempt from the 30% apprenticeship graduation requirement specified in Section 3 (A) (vi) for the period measured from the date the apprenticeship program is registered with the New York State Department of Labor plus the specific trade's program length plus two years.

#### Section 11. Effective Dates.

This Local Law shall take effect 30 days after the filing with the Secretary of State, in accordance with Section 27 of the New York State Municipal Home Rule Law.

SPONSORS: PATRICK BURKE - APRIL N.M. BASKIN - JOHN BRUSSO



## ARTICLE 2 – LOCAL LAW NO. 3-2018 RULES AND REGULATIONS

### RULES AND REGULATIONS ADOPTED BY THE ERIE COUNTY COMMISSIONER OF THE DEPARTMENT OF PUBLIC WORKS REGARDING: COUNTY OF ERIE LOCAL LAW NO. 3-2018

A LOCAL LAW in relation to a requirement for New York State Certified Worker Training Programs by contractors and subcontractors under construction contracts, as defined herein, with the County of Erie.

Pursuant to Section 5 of Erie County Local Law No. 3-2018, "the Commissioner of the Erie County Department of Public Works shall promulgate such rules and regulations that are lawful, necessary and appropriate to implement, enforce or otherwise carry out the purposes of this Local Law..." Such rules and regulations are as follows:

#### 1. Definitions.

"Bidders" – an individual or entity which submits a formal Bid for a Construction Contract, as hereinafter defined.

"Bids" – formal bids submitted for a Construction Contract, as hereinafter defined, in accordance with New York General Municipal Law.

"Commissioner" – Erie County Commissioner Department of Public Works

"Construction Contract" – a contract for a Project which includes more than an incidental amount of construction-type activity performed by persons in trades or careers for which there exists an NYSCATP, as hereinafter defined.

"Contracting Agency" – a department, division, board, agency or office of the County, an entity undertaking a Project that Erie County funds indirectly, or an entity undertaking a Project with the specific intent of leasing the completed Project to the County, which solicits and receives Bids for a Construction Contract.

"Local Law" – Erie County Local Law 3-2018

"Monitoring Agency" – the Erie County Equal Employment Opportunity Office

"New York State Certified Apprentice Training Program" or "NYSCATP" - a state registered and regulated apprenticeship program(s) approved by the Commissioner of the New York State Department of Labor in accordance with Article 23 of the Labor Law and the Rules and Regulations thereto.

"Prime Contractor" – the party with whom the Contracting Agency contracts with on a Project.

"Project" – the construction, reconstruction, improvement, rehabilitation, installation, alteration, renovation, demolition or otherwise of any building, facility, roads, highways, bridges, or physical structure of any kind, estimated by the Contracting Agency as having a cost to complete in excess of \$250,000, for which the County is a direct or indirect party to a Construction Contract. Projects include those: that Erie County funds directly, either in whole or in part; that Erie County funds indirectly, either in whole or in part, by providing funds to a separate entity to perform the construction-type activity; privately financed construction projects specifically built with the intent of leasing the completed project to Erie County; and construction projects built under Erie County's direction and later paid for with Erie County funds.

"Rules" – these rules and regulations promulgated by the Commissioner pursuant to the Local Law.

“Subcontractor” – A subcontractor to a Prime Contractor.

“Workforce” – the total worker hours anticipated on the Construction Contract to be undertaken by workers in careers or trades for which there exists an NYSCATP.

## 2. Rules and Regulations.

A. Each Contracting Agency shall include in its bid specifications provisions for the implementation of the Local Law and these Rules. Bids shall demonstrate a Bidder’s ability to comply with the Local Law and these Rules and in the event that Bidder is a successful Prime Contractor on a Construction Contract.

B. Bidder shall submit as part of the Bid a copy of the certification of approval of the NYSCATP by the New York State Department of Labor which will be used by the Bidder in connection with the Construction Contract. Such NYSCATP shall be a NYSCATP registered by the NYS Commissioner of Labor which will be utilized by the Bidder on the Construction Contract by the Bidder as a Prime Contractor or by the Bidder’s Subcontractor(s).

C. As part of its’ Bid, Bidder shall provide a written plan demonstrating how apprentices will be utilized by the Bidder as Prime Contractor or by Subcontractor(s) to the Bidder as Prime Contractor. Such plan shall include at a minimum, but not be limited to the following:

- i. An organized, written plan in place that embodies the terms and conditions of employment, training and supervision of one or more apprentices;
- ii. A schedule of wages to be paid to the apprentices consistent with the skills required and approved by the New York State Department of Labor;
- iii. Equal employment opportunity and affirmative action plans.
- iv. Demonstration that ten percent (10%) of the Workforce of the Prime Contractor (inclusive of the workforce utilized by any Subcontractor(s) to the Bidder) shall consist of persons participating in New York State Certified Apprentice Training Programs.

D. In the alternative Bidder may provide a statement as to the inapplicability of apprenticeship participation on the Prime Contract and the related subcontracts due to the lack of career opportunities in NYSCATP approved by New York State Department of Labor Commissioner or that the magnitude of the Construction Contract would make use of apprentices impracticable. In the event that Bidder provides a statement that there is a lack of such career opportunities or the use of apprentices on the Construction Contract is impracticable, said Bidder may not be deemed non-responsive by virtue of the submission of such a statement, as determined by the Monitoring Agency. Applicability of this section will be viewed within the total Workforce of each Prime Contract and not as a function of each subcontract of the Construction Contract as a whole.

E. As part of its’ Bid, Bidder shall provide affirmation of its commitment toward acceptable achievement or progress towards the County of Erie workforce development and diversification goal in all construction contracts of thirty percent (30%) minority and female participation combined in project personnel including trades people, trainees, journeymen, apprentices and supervisory staff.

F. Contracting Agency may determine prior to the advertisement of bids for the Project or prior to the award of Bids that the nature of the Construction Contract does not provide an adequate opportunity for the use of NYSCATP for such reasons including, but not limited to, that:

- i. 75% or more of the value of the Construction Contract involves material, equipment and/or supplies; or
- ii. There is a lack of NYSCATP approved by the Department of Labor for at least 75% of the work hours anticipated to be spent on construction-type activity involved in the Construction Contract; or
- iii. The Construction Contract is in response to an emergency condition; or
- iv. The Project is estimated to cost less than \$250,000 or the Bid amount is less than \$250,000; or
- v. None of the bids received were from Bidders who had an NYSTACP

G. All Bids shall be reviewed by the Monitoring Agency within 10 business days of delivery of the Bids by the Contracting Agency to the Monitoring Agency. A Contracting Agency shall not reject any Bid as being non-responsive to the requirements of the Local Law and these Rules, unless the Monitoring Agency, within 10 business days of receipt of Bids from the Contracting Agency, provides the Contracting Agency with a written report recommending non-responsiveness of the Bidder and the reasons therefore. Determination of a Bidder's compliance with the Local Law and these Rules shall be the responsibility of the Monitoring Agency.

H. The Contracting Agency is permitted to require within the Bid specifications for a Project, a reasonable fee for the Prime Contractor to hire an independent monitor to review and report on the diversification goals of the Local Law

### 3. Effect

These Rules and Regulations shall become effective immediately. No Rule or Regulation promulgated herein shall be disapproved by the Erie County Legislature unless and until such time as the public, following 10 days advertised notice, is given the opportunity to comment upon such rule or regulation.

## **ARTICLE 3 – LOCAL LAW NO. 3 – 2018 FORMS**

Bound following this page are the following which are part of the Contract Documents:

1. New York State Certified Apprenticeship Training Program Certification (1 page) (SUBMIT WITH BID)
2. Apprenticeship Utilization Certification for Final Payment (1 page)

NEW YORK STATE CERTIFIED APPRENTICESHIP  
TRAINING PROGRAM CERTIFICATION

**Pursuant to Erie County Local Law 3-2018 the following MUST be submitted along with supporting documentation** unless the Contracting Agency has otherwise determined under Section 2f of the Erie County Rules and Regulations that the New York State Certified Apprenticeship Training Program does not apply.

TO BE FILLED OUT BY BIDDER: please check that which applies on sign below.

[ ] Enclosed is a copy of the certification of approval of the New York State Certified Apprenticeship Training Program (NYSCATP) by the New York State Department of Labor which, as Bidder, will use in connection with the construction contract. Also enclosed is a written plan demonstrating how apprentices will be utilized by the Bidder as Prime Contractor or by the Subcontractor(s) to the Bidder as Prime Contractor. Such Plan shall include at a minimum:

- i. An organized written plan in place that embodies the terms and conditions of employment, training and supervision of one or more apprentices;
- ii. A schedule of wages to be paid to the apprentices consistent with the skills required and approved by the New York State Department of Labor;
- iii. Equal employment and affirmative action plans;
- iv. Workforce development and diversification goals to ensure that the contractor will diligently work toward a minority workforce goal of 30% minority and female participation combined in project personnel including trades people, trainees, journeymen, apprentices and supervisory staff;
- v. A minimum of ten percent (10%) of the total construction workers. Trades people, trainees, journeymen, and apprentices employed at any given time on a particular project by any and all contractors or subcontractors must be consist of persons participating in a NYSCATP; and
- vi. In all cases, such Certified Apprenticeship Training Program must be specific to the type and scope of work which is being performed and must have a graduation rate of at least thirty percent (30%) as determined by the New York State Department of Labor.

[ ] Enclosed is a detailed explanatory written statement as to the inapplicability of Apprenticeship participation due to: the lack of career opportunities in NYSCATP Approved by New York State Department of Labor Commissioner; OR the magnitude of the construction contract which would make use of apprentices impracticable.

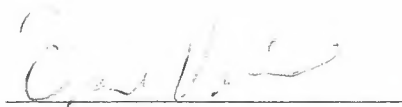

SIGNATURE

Vision Construction Inc 1/11/22

COMPANY NAME

DATE

**APPRENTICESHIP UTILIZATION**  
**CERTIFICATION FOR FINAL PAYMENT**

STATE OF NEW YORK

COUNTY OF ERIE

David Visone being duly sworn, deposes and says that he is the Contractor for the work associated with VISONE CONSTRUCTION, INC for the COUNTY OF ERIE, the Owner; and says that he is the President, the contracting company.

Deponent certifies that in accordance with Erie County Local Law 3-2018, \_\_\_\_\_% is the final percentage of persons participating in an apprenticeship program that the undersigned employed in the performance of this Contract.

Deponent further states that he has read the above statement and knows the content thereof, and that the same is true of his own knowledge.

Visone Construction, Inc  
(Name of Contractor)

"CORPORATE  
SEAL"

By Emilie

Sworn to before me this

11 day of January 2024

Emily Feeley  
Notary Public or Commissioner of Deeds

NOTE: This form shall be executed in triplicate.

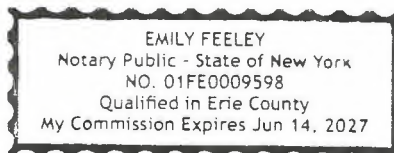



## SECTION 00 73 39

### MINORITY BUSINESS ENTERPRISE REQUIREMENTS

This Section details minority, women, and service-disabled veteran owned business enterprise requirements for the Project. This Section is part of the Contract Documents.

	Page
Article 1 – Minority/Women’s/Service-Disabled Veteran Owned Business Utilization Commitment .....	2
Article 2 – Prime Contractor Affidavit.....	6
Article 3 – Minority Business Enterprise Utilization Forms.....	6
Article 4 - Waiver Request.....	6
Article 5 – County of Erie Local Law No. 6 – 1987.....	6
Article 6 – County of Erie Local Law No. 5.1-2023.....	9

#### FORMS:

Prime Contractor Affidavit (PRINT AND SUBMIT WITH BID) (1 page)

Minority Business Enterprise & Service-Disabled Veteran Owned Business Utilization Form -Part A , Part D Form, and Waiver Recommendation (SUBMIT WITH BID or WITHIN 3 DAYS – Included in Invitation to Bid Exhibit “H”) (6pages)



## ARTICLE 1—MINORITY/WOMEN’S/SERVICE-DISABLED OWNED BUSINESS UTILIZATION COMMITMENT

Erie County’s Minority and Women’s Business Utilization Local Law No. 6, 1987 requires all prime Contractors awarded construction contracts let by the County of Erie to exemplify Affirmative Action and subcontract to minority and women’s business enterprises MBE/WBE. Further, Erie County’s Service-Disabled Veterans Utilization Local Law No. 5-1, 2023 requires all prime Contractors awarded construction contracts let by the County of Erie to exemplify Affirmative Action and subcontract to service-disabled veteran-owned business enterprises (SDVOB).

For the purpose of these regulations, the term “Minority Business Enterprise” refers to a business at least fifty-one percent (51%) of which is owned and controlled by minority group members. Minority group members are citizens of the United States who are Blacks, Hispanics, Asian Americans, American Indians, Eskimos and Aleuts. MBE’s must be certified by the Erie County, New York State, and/or the Erie County/City of Buffalo Joint Certification Committee.

For the purpose of these regulations the term “Women’s Business Enterprise” refers to a business at least fifty-one percent (51%) of which is owned and controlled by women. WBE’s must be certified by Erie County, New York State, and/or the Erie County/City of Buffalo Joint Certification Committee.

For the purpose of these regulations the term “Service-Disable Veteran-Owned Business Enterprise” refers to a business at least fifty-one percent (51%) of which is owned and controlled by service-disabled veterans. SDVOBs must be certified under the New York State Service-Disabled Veteran-Owned Business Act.

Be it further understood that in order for a Minority and/or Women’s Business to be certified as such by Erie County and/or the Erie County/City of Buffalo Joint Certification Committee and the proposed business is incorporated, that the MBE/WBE must own and control 51% of the stock authorized to be issued by the corporation. Such authorization is made in the Certificate of Incorporation.

The County of Erie has determined that a goal of ten percent (10%) of the total contract value represents a fair share of minority business utilization, two percent (2%) of the total contract value represents a fair share of women’s business utilization, and six percent (6%) of the total contract value represents a fair share of service-disabled veteran-owned business utilization on each construction contract awarded.

This local law requires that positive efforts be made by recipients of Erie County construction contracts to utilize minority and women owned business sources for supplies, services, and professional services, allowing these sources the maximum feasible opportunity to compete for contracts, subcontracts, and third-tier contracts to be performed.

All prime contractors awarded Erie County contracts estimated to exceed \$100,000 are to take positive steps to afford fair opportunities to MBEs, WBEs, and SDVOBs. Positive steps shall include not be limited to:

- A. Utilizing a source list of bona fide minority, women’s, and service-disabled veteran business enterprise (Appendix B);
- B. Solicitations of bids from MBEs, WBEs, and SDVOBs particularly of those located in Erie, Niagara, Cattaraugus, and Chautauqua Counties.
- C. Giving minority, women, and service-disabled veteran firms sufficient time to submit proposals in response to solicitations; and

- D. Maintaining records showings minority, women, and service-disabled veteran business enterprises and specific efforts to identify and award contracts to these companies.

Each Contractor bidding on a County of Erie Contract is to contact MBEs, WBEs, SDVOBs and solicit bids for various aspects of each project. The Contractor is to supply the County MBE/WBE/SDVOB office with information regarding contracts for services and products with minority, women, service-disabled veteran business enterprises and the dollar amount to each contract on the Minority Business Utilization Report.

- E. Where the MBE, WBE, SDVOB is supplier, a credit of one hundred percent (100%) of the dollar value of the subcontract between the MBE, WBE, and SDVOB and the Contractor shall be awarded toward the fulfillment of the appropriate goal.

- 1. For purposes of this Section, an MBE, WBE, or SDVOB will be considered a supplier when it:
  - a. Assumes actual and contractual responsibility to furnish supplies and/or materials and is the manufacturer of those supplies and/or materials; or
  - b. Is recognized by the manufacturer involved as a distributor of its supplies and/or materials; and
  - c. Owns or leases a warehouse, yard, building or other facility which is necessary and customary to carry out the purported function of the business; and
  - d. Distributes, delivers and services the supplies and/or materials with its own staff.

- F. Where an MBE, WBE, or SDVOB performs a sales function, which is customarily performed as a distinct and necessary part of the supply process, a credit of twenty-five percent (25%) of the dollar value of the subcontract between the MBE, WBE, or SDVOB, the Contractor will be awarded toward the fulfillment of the appropriate goal;

- G. Where the MBE, WBE, or SDVOB performs a function or service which is commercially unnecessary, such as acting as a passive conduit in the supply process of duplicating a service provided by others in the same chain of supply from manufacturer to purchaser, no credit will be granted towards the appropriate goal.

- H. The qualifications set for in subsections (E), (F) and (G), above of this Action shall be certified by the Erie County Equal Employment Opportunity Office.

The three (3) lowest bidders shall submit to Erie County the Minority Business Enterprise Utilization Report, Part A with the Bid or within the designated time. Part A includes a list of MBEs, WBEs, and SDVOBs from whom the Contractor has solicited bids, or with whom the Contractor has signed a binding contractual agreement or with whom the Contractor is presently negotiating an agreement. A Contractor's bid shall not be considered where the Contractor fails to submit this report or where an examination of the report evidences failure by the Contractor to comply with the Affirmative Action requirements of the Contract.

In the event of a joint venture participating in this MBE/WBE/SDVOB Program, the Joint Venture Disclosure Affidavit must be submitted with Part A by all parties involved. Only to the extent that a minority, women's, service-disabled veteran business enterprise contributes to and is paid for its participation in a Joint Venture will that dollar amount be credited towards the 10%, 2%, and/or 6%

respectively goal of minority/women's/service-disabled veteran participation in the County of Erie MBE/WBE/SDVOB Program.

MBEs, WBEs, and SDVOBs must be certified before their participation may be credited toward the respective 10%, 2%, and 6% goal. Where the proposed MBE, WBE, and/or SDVOB is not certified by Erie County, New York State, or the Erie County/City of Buffalo Joint Certification Committee or under the New York State Service-Disabled Veteran-Owner Business Act, the appropriate Certification Disclosure Affidavit must be filed with the appropriate Erie County/City of Buffalo Department. Forms and lists of certified MBEs/WBEs/SDVOBs may be obtained by calling 858-8480.

A Minority/Women's/Service-Disabled Veteran Business Enterprise Utilization Waiver Request must be completed and submitted with the Utilization Report Part A to the County of Erie along with the Bid or within the designated time. Waivers shall be granted only where the availability of MBEs, WBEs, and/or SDVOBs in the market area of the project is less than the respective 10%, 2%, 6% goal.

Sufficient information must be provided on the Minority, Women's, Service-Disabled Veteran Business Enterprise Utilization Waiver Request to ascertain whether a waiver should be approved, conditionally approved or rejected by the Department of Public Works or the Department of Environment and Planning on the advice of the MBE/WBE/SDVOB Office.

A waiver approval limits the Contractors obligation to solicit MBEs, WBEs, and/or SDVOBs for a particular project only. It does not relieve the Contractor of MBE/WBE/SDVOB utilization for any other County of Erie project on which he submits a bid.

Conditional approval of the waiver request makes it necessary for the contractor to continue soliciting MBEs/WBEs/SDVOBs for contracting purposes, after he has been declared the low bidder.

An MBE/WBE/SDVOB Utilization Waiver Request will be rejected if the Contractor:

1. Fails to provide information on the Minority, Women's, Service-Disabled Veteran Business Enterprise Utilization report at the time of the Bid Opening or within the designated time.
2. Provides fraudulent information on the MBE/WBE/SDVOB reports.
3. Fails to make an honest good faith effort to recruit and contract with MBEs/WBEs/SDVOBS or
4. Takes any other action which is contrary to the spirit and intent of the law.

The information provided on the MBE/WBE/SDVOB Waiver Request and the MBE/WBE/SDVOB Utilization Report will be considered concurrently to determine if a waiver should be approved, conditionally approved or rejected.

The successful low bidder shall submit to the Erie County MBE/WBE/SDVOB Office within 15 business days of the bid opening, a schedule for minority/women's/service-disabled veteran business enterprise participation, listing the minority/women's/ service-disabled veteran business enterprise with whom the Contractor intends to subcontract, specifying the agreed price to be paid for such work, and identifying in detail the contract item(s) or parts to be performed by each minority/women's/ service-disabled veteran business enterprise.

A letter of intent to enter into a subcontract or purchase agreement, contingent upon contract award, indicating the agreed upon price and scope of work, shall be provided, signed by both the Contractor and the minority/women's/service-disabled veteran business enterprise. The Prime Contractor shall not substitute or delete the listed minority, women's, and/or service-disabled veteran business enterprise without the written consent of Erie County. In the event that the MBE/WBE/SDVOB goal for the Contract

is not met, the Contractor shall provide sufficient documentation to establish that every positive effort was made to identify, solicit and negotiate with MBEs, WBEs, SDVOBs in pursuit of the goal. Such documentation includes, but is not limited to, advertisement in minority-focus media, written contact with minority contractors' associations and community groups and copies of direct solicitation of individual minority businesses indicating sufficient time to prepare quotations. Where an MBE/WBE/SDVOB is rejected due to price, the contract shall provide documentation of the successful bidder's price along with evidence showing the work to be performed in the same, and not a reduced portion thereof.

The Contractor shall provide to the Erie County MBE/WBE/SDVOB Office copies of all subcontracts and/or purchase agreements with minority/women's/ service-disabled veteran business enterprise within 15 days of Contract award. A Notice to Proceed with construction shall not be issued until acceptable documentation is received.

The Final Minority Business Enterprise Utilization Report, Part D certifies the total dollar amount expended to MBEs/WBEs/SDVOBs Part D and all cancelled checks payable to the MBEs/WBEs/SDVOBs on the project is to be submitted to the Erie County MBE/WBE/SDVOB office with the request for final payment.

In the event a Contractor fails to comply with these provisions, Erie County may:

1. Summon the Contractor to a hearing.
2. Withhold progress payments in part or in full.
3. Cancel the Contract.
4. Bar awards of future contracts until the Contractor can demonstrate that he will comply.

It is, hereby, the County of Erie's commitment to assure that on all contracts awarded, Prime Contractors expend a fair share of the contract with bonafide Minority, Women, and Service-Disabled Veteran Owned business enterprise in accordance with the goals set forth in the Minority Business Utilization Local Law, No. 6, 1987 and Service-Disabled Veterans Utilization Local Law No. 5-1, 2023.

Failure to comply with the provisions of the law shall constitute a break of Contract subject to all remedies available to Erie County.

The Prime Contractor and all Minority, Women, and Service-Disabled Veteran Owned Business subcontractors are bound by all requirements as put forth in the County of Erie Standard General Conditions and all modifications thereto contained in these Contract Specifications.

**ARTICLE 2—PRIME CONTRACTOR AFFIDAVIT**

2.01 Bound at the end of this Section is the Prime Contractor Affidavit which is part of the Contract Documents (one page). THIS FORM MUST BE SUBMITTED WITH BID.

**ARTICLE 3—MINORITY BUSINESS ENTERPRISE UTILIZATION FORMS**

3.01 Bound at the end of this Section is the Erie County Minority/Women/Service-Disabled Veteran Business Enterprise Utilization Report (Parts A thru D) which are part of the Contract Documents (8 pages). PART A MUST BE SUBMITTED WITH BID OR WITHIN 3 DAYS.

**ARTICLE 4—WAIVER**

4.01 Bound at the end of this Section is the Waiver which is part of the Contract Documents (1 page). THIS FORM MUST BE SUBMITTED WITH BID OR WITHIN 3 DAYS, IF USED.

**ARTICLE 5—COUNTY OF ERIE LOCAL LAW NO. 6- 1987**

COUNTY OF ERIE  
LOCAL LAW NO. 6 - 1987

A LOCAL LAW requiring a minority business utilization and women-owned owned business utilization commitment by persons or firms contracting with the County of Erie:

BE IT ENACTED BY THE ERIE COUNTY LEGISLATURE AS FOLLOWS:

Section 1. The following provisions shall be inserted in and made a condition of all bid specifications prepared by the Erie County Department of Planning and Environment and/or the Erie County Department of Public Works and advertised after the effective date of the local law which was estimated by the County to result in a contract exceeding \$100,000.00.

Minority Business – Utilization Commitment

A) The Contractor shall take affirmative action to utilize bona fide minority business enterprises/women business enterprises for subcontracts on this project. Affirmative action shall include, but not be limited to: (1) Utilizing a source list of minority business enterprises (MBE) and women-owned business enterprises (WBE), (2) Solicitation of bids from MBE's and WBE's, particularly those located in Erie, Niagara, Cattaraugus and Chautauqua Counties, (3) Giving MBE's and WBE's sufficient time to submit proposals in response to solicitations, (4) maintaining records showing MBE's and WBE's and specific efforts to identify and awards contracts to those companies, and (5) a goal of awarding at least ten percent (10%) of the total dollar value of the Contract to MBE's and at least two percent (2%) of the total dollar value of the Contract to WBE's or, of those contracts governed by federal or state regulations with respect to MBE and/or WBE hiring, the prevailing percentage set forth therein, whichever is higher, subject to waiver as provided for below.

B) The three (3) lowest bidders on each contract subject to this law shall submit to the County MBE/BE office, with the bid (or within 3 business days of the bid opening), a list of all MBE's and WBE's from whom the Contractor has solicited bids or with whom the Contractor has signed a binding

contractual agreement of with whom the Contractor is presently negotiating an agreement, for the purposes of meeting the MBE and WBE utilization goals provided for in subdivision (A) (5) above. A Contractor's bid shall not be considered where the Contractor fails to submit such a list as provided for herein. A Contractor's bid shall not be considered where examination of said list of MBE's and WBE's evidences failure by the Contractor to comply with the affirmative action requirements provided for herein, except that the County may, upon written request by the Contractor, grant a complete or partial waiver of the provisions of Subdivision (A) (5), where the availability of MBE's and/or WBE's in the market area of the project is less than the ten percent (10%) and two percent (2%) goals above.

C) As evidence of compliance with the goals set forth in Subdivision (A) (5) above, the Contractor shall submit to the County MBE/WBE office, within fifteen (15) business days of the bid opening, a schedule for MBE and WBE participation, listing the MBE's and WBE's with whom the Contractor intends to subcontract, specifying the agreed price to be paid for such work, and identifying in detail the contract item(s) or parts to be performed by each MBE and each WBE. A letter of intent to enter into a subcontract or purchase agreement, contingent upon contract award, indicating the agreed upon price and scope of work, shall be provided, signed by both the Contractor and the MBE or WBE. The Prime Contractor shall not substitute or delete the listed MBE's or WBE's without the written consent of Erie County.

D) As evidence of compliance with the goals set forth in subdivision (A)(5) above, the Contractor shall provide to Erie County MBE/WBE office, copies of all subcontracts and/or purpose agreements with MBE's and WBE's within fifteen (15) days of contract award. A motion (notice) to proceed with construction shall not be issued until such documentation is received.

E) As evidence of compliance with the goal set forth in Subdivision (A)(5) above, the Contractor shall submit to the County MBE/WBE office, when the project is thirty percent (30%) complete, a list of MBE's and WBE's on the project, the dollar amounts paid to that date and the estimated amount remaining to be spent. This same information is required at seventy-five percent (75%) completion and a final accounting must accompany the final payment request.

F) Failure to comply with the provisions set forth herein shall constitute a breach of this Contract subject to all remedies available to the County.

G) For the purpose of this section, the term "minority business enterprise (MBE)" shall mean a business which performs a commercially useful function, at least fifty-one percent (51%) of which is owned by minority group members or, in the case of a publicly owned business, at least fifty-one percent (51%) of all stock is owned by minority group members. Such ownership shall be certified by the Erie County Equal Employment Opportunity Office. For the purposes of this paragraph, "minority group members: are citizens of the United States who are Black, Hispanic, Asian-American, American Indian, Eskimo or Aluet. (For purposes of this section, the term "subcontract" includes all construction, modification, supplies and material, and service work contracted for by the Contractor in the prosecution of this work.)

H) For the purposes of this Section, the term "women-owned business enterprise (WBE)" shall mean a business which performs a commercially useful function, at least fifty-one (51%) of which is owned by a woman or women or, in the case of a publicly owned business, at least fifty-one (51%) of all stock is owned by a woman or women. Such ownership shall be certified by the Erie County Equal Employment Opportunity Office.

I) Where the MBE or WBE is a supplier, a credit of one hundred percent (100%) of the dollar value of the subcontract between the MBE or WBE and the Contractor shall be awarded toward the fulfillment of the appropriate goal, as set forth in Section 1 (A)(5) above.

1. For purposes of this Section, a MBE or a WBE will be considered a supplier when it:
  - a. assumes actual and contractual responsibility to furnish supplies and/or materials and is the manufacturer of those supplies and/or materials; or
  - b. is recognized by the manufacturer involved as a distributor of its supplies and/or materials; and
  - c. owns or leases a warehouse, yard, building or other facility which is necessary and customary to carry out the purported function of the business; and
  - d. distributes, delivers and services the supplies and/or materials with its own staff.

J) Where an MBE or WBE performs a sales function, which is customarily performed as a distinct and necessary part of the supply process, a credit of twenty-five percent (25%) of the dollar value of the subcontract between the MBE or WBE the Contractor will be awarded toward the fulfillment of the appropriate goal, as set forth in Section 1(A)(5) above.

K) Where the MBE or WBE performs a function or service which is commercially unnecessary, such as acting as a passive conduit in the supply process or duplicating a service provided by others in the same chain of supply from manufacturer to purchaser, no credit will be granted toward the appropriate goal, as set forth in Section 1 (A)(5) above.

L) The qualifications set forth in subsections (I), (J) and (K), above, of this Action shall be certified by the Erie County Equal Employment Opportunity Office.

M) For purposes of this Section the term "subcontract" includes all construction, modification, service work, supplies and material contracted for by the Contractor in the prosecution of this work.

SECTION 2. The County Executive shall appoint a minority business enterprise and women-owned business enterprise utilization advisory board of nine (9) members consisting of County personnel, legislators, minority contractors, female contractors and community and business representatives, which shall review program administration and implementation on a regular basis and shall submit an annual report to the County Executive and County Legislature. This committee shall be empowered to promulgate regulations to provide for the administration of this local law.

SECTION 3. The Legislature shall conduct hearings annually to assess the impact of the local law.

SECTION 4. This local law shall take effect immediately.



EC LEG MAY 5 '23

**COUNTY OF ERIE**

LOCAL LAW INTRO NO. 5-1 -2023

LOCAL LAW NO. \_\_\_\_\_-2023

**THE SERVICE-DISABLED VETERANS UTILIZATION ACT**

A LOCAL LAW in relation to ensuring that service-disabled veterans have greater participation in Erie County contracts.

THEREFORE, BE IT ENACTED by the Legislature of the County of Erie, as follows:

**SECTION 1. LEGISLATIVE INTENT**

Erie County is home to many men and women who have faithfully served their country as members of military and national guard, some of whom became disabled during their service. It is the intent of the Erie County Legislature to honor this service and sacrifice for our nation by promoting and encouraging the continued economic development of service-disabled veteran-owned businesses by ensuring greater participation in County contracts.

**SECTION 2. DEFINITIONS**

The following terms shall have the meanings indicated.

- 1 "State-Certified Business" shall mean a business that is a certified service-disabled veteran-owned business under the New York State Service-Disabled Veteran-Owned Business Act.
- 2 "Departments and Offices" shall mean
  - a) Any County department; or
  - b) Any division, office or bureau of any County department, or Erie County Community College; or
  - c) A board, a majority of whose members are appointed by the County Executive or who serve by virtue of being County officers or employees.

### **SECTION 3. OUTREACH**

The Erie County Office of Equal Employment Opportunity (the "EEO") shall be responsible for outreach to State Certified Businesses in order to encourage participation in public contract bidding opportunities. The EEO shall maintain a data base of all State-Certified Businesses.

### **SECTION 4. PARTICIPATION**

All Departments and Offices of Erie County shall make good faith efforts to ensure State-Certified Businesses have greater participation in County contracts by aiming for at least a six percent participation rate of State-Certified Businesses on County contracts.

### **SECTION 5. RECORDS**

All Departments and Offices of Erie County shall maintain documents reflecting the good faith efforts made by their Department.

### **SECTION 6. SEVERABILITY**

If any clause, sentence, paragraph, subdivision, section or part of the Local Law or the application thereof, to any person, individual, corporation, firm, partnership, entity or circumstance, shall be adjudged by any court of competent jurisdiction to be invalid or unconstitutional such order of judgment shall not affect, impair, or invalidate the remainder thereof, but shall be confined in its operation to the clause, sentence, paragraph, subdivision, section or part of this Local Law or in its application to the person, individual, corporation, firm, partnership, entity, or circumstance directly involved in the controversy in which such judgment or order shall be rendered.

### **SECTION 7. EFFECTIVE DATE**

This Local Law shall take effect upon filing with the New York State Secretary of State on August 1, 2023.



## SECTION 00 73 40

### DISADVANTAGED WORKER REQUIREMENTS

This Section details local and disadvantaged worker requirements for the Project. This Section is part of the Contract Documents.

	Page
Article 1 – Erie County Executive Order No. 18.....	2
Article 2 – Rules and Regulations Implementing Erie County Executive Mark C. Poloncarz Order #18....	4
Article 3 – Executive Order No. 18 Forms.....	8
1. Erie County Executive Order No. 18 Attestation and Statement of Workforce (PRINT AND SUBMIT WITH BID)	
2. Erie County Local and Disadvantaged Worker Certification (SUBMIT WITH AGREEMENT)	
3. Executive Order No. 18 Erie County Local and Disadvantaged Worker Compliance Certification – Waiver Request	

**ARTICLE 1—ERIE COUNTY EXECUTIVE ORDER #018**

EXECUTIVE ORDER #18  
ERIE COUNTY CONSTRUCTION PROJECT BID DOCUMENTS SHALL INCLUDE LOCAL AND  
DISADVANTAGED WORKER REQUIREMENTS

Whereas, Erie County annually appropriates over \$25,000,000 in tax dollars for expenditures related to public works construction projects; and

Whereas, Erie County awards contracts to private firms to provide the construction services associated with budgeted projects; and

Whereas, while unemployment in Erie County as a whole is comparable to other metropolitan regions in the United States, the unemployment rate within certain zip codes located in Erie County is as high as 21.7% and the poverty rate as high as 44.7%; and

Whereas, there are 182,200 working age individuals in the region who are either unemployed or underemployed and seeking work; and

Whereas, low-income or otherwise disadvantaged individuals residing in Erie County experience higher rates of unemployment compared to other individuals;

Whereas, the purpose of this order is to foster construction employment opportunities for qualified local residents, underemployed individuals or otherwise disadvantaged workers on those construction projects located within the geographic boundaries of Erie County which are bid by the County of Erie ("Erie County construction project(s)").

Now, Therefore, I, Mark C. Poloncarz, Erie County Executive, by virtue of the authority vested in me by Erie County's Charter Sections 301 and 302, do hereby order as follows:

1. It is ordered that on and after April 30, 2018, all bids for Erie County construction projects initiating out of the Erie County Department of Environment and Planning Division of Sewerage Management and on and after October 1, 2017, all other bids for Erie County construction projects wherever so initiated, and all associated contracts involving an expenditure of \$250,000 or greater which utilize not less than three workers to complete the project shall require that:
  - a) Entirely 100% of work hours performed by residents of New York State on an Erie County construction project will be worked by residents of the Local Labor Area (Erie County, Niagara County, Chautauqua County, Cattaraugus County, Allegany County, Wyoming County, Genesee County, Orleans County).
  - b) At least 70% of total work hours performed by residents of New York State on an Erie County construction project will be worked by residents of the County of Erie.
  - c) For the remainder of the calendar year subsequent to the effective date of this Order as specified above in Section 1, and for the entirety of the calendar year that follows, at least 20% of total work hours performed by residents of New York State, which percentage may be wholly or partly included within the hourly requirement contained in sub-section (b) above, used on an Erie County construction project will be worked by residents of Erie County who reside in zip codes with a poverty rate of 20% or higher, and/or, in any ratio, disadvantaged workers who reside in Erie County. A disadvantaged worker is a resident who has a household income below 50% of the Area Median Income ("AMI"); or has been released from prison within the last 10 years; or

participates in the Temporary Assistance for Needy Families program; or participates in the Supplemental Nutrition Assistance Program; or has been unemployed for at least 12 consecutive months. On the first day of the second full calendar year from such effective date and continuing thereafter, the applicable percentage of total work hours performed referenced in this subsection above will move upward from 20% to 30%. The applicable zip codes as referenced above will be determined annually by the Erie County Division of Equal Employment Opportunity and will be provided to potential contractors in all request for bids documents; and

2. It is further ordered that work hours performed by individuals residing outside of New York State will not be included in the requirements set forth above; and
3. It is further ordered that where an Erie County construction project is funded in whole or in part with Federal Highway Administration monies, those projects are exempt from the requirements specified above to avoid conflict with federal law or regulation; and
4. It is further ordered that failure to adhere to the requirements herein, as further delineated in all formal construction contracts and any rules and regulations promulgated pursuant to Section 5 below, will constitute grounds for immediate termination of the underlying contract and will further result in the Contractor being deemed a non-responsible bidder for a period of twelve months. Once grounds for immediate termination are established, actual contract termination will be at the discretion of Erie County; and
5. It is further ordered that the Erie County Department of Law must promulgate, and update annually where necessary, separate formal rules and regulations with respect to implementation of the requirements contained herein as applied respectively and distinctly to Erie County construction projects initiating out of the Erie County Department of Environment and Planning Division of Sewerage Management and to Erie County construction projects wherever else so initiated. The Erie County Department of Law must also assure compliance with this Executive Order within the contract approval process; and
6. It is further ordered that the Erie County Division of Equal Employment Opportunity establish a procedure for compliance monitoring and periodic auditing of construction contractor hiring rates.

Given, under my hand and the Privy Seal of the County of Erie in the City of Buffalo this twenty seventh day of September, in the year two thousand seventeen.

County of Erie

By: \_\_\_\_\_

Mark C. Poloncarz  
Erie County Executive

**ARTICLE 2—RULES AND REGULATIONS IMPLEMENTING ERIE COUNTY EXECUTIVE MARK C. POLONCARZ ORDER #18**

**RULES AND REGULATIONS IMPLEMENTING  
ERIE COUNTY EXECUTIVE MARK C. POLONCARZ ORDER #18**

**PURPOSE**

The Erie County Attorney's Office promulgates these Rules and Regulations pursuant to Section 5 of Erie County Executive Mark C. Poloncarz Order #18 dated September 27, 2017 ("EO #18"). These Rules and Regulations are intended to articulate guidelines for implementing the provisions of EO #18 as they relate to those Erie County construction projects.

**DEFINITIONS**

1. **ERIE COUNTY CONSTRUCTION PROJECT** shall mean construction projects bid by Erie County and located within the geographic boundaries of Erie County which involve an expenditure of \$250,000 or more and which utilize not less than three construction workers to complete the project.
2. **CONSTRUCTION SUBCONTRACT** shall mean any subcontract entered into by a contractor working on an Erie County Construction Project which, by its terms, engages such subcontractor to provide work hours on an Erie County Construction Project.
3. **CONTRACTOR OR SUBCONTRACTOR** shall mean a contractor or subcontractor that directly employs construction workers who provide work hours on an Erie County Construction Project.
4. **CONSTRUCTION WORKER** shall mean a laborer, workman or mechanic who resides in the local labor area (Erie County, Niagara County, Chautauqua County, Cattaraugus County, Allegany County, Wyoming County, Genesee County, Orleans County) and is directly involved in the construction, reconstruction, improvement, rehabilitation, installation, alteration, renovation, demolition or otherwise providing for any building, facility, roads, highways, bridges, or physical structure of any kind, but does not include professional services employees.

**APPLICATION**

All Erie County Construction Projects ("Project" or "Projects") as defined above are subject to the provisions of EO #18. The Commissioner or his/her Designee or the Division Head or his/her Designee of the Erie County Department or Division who solicits a bid for an Erie County Construction project ("the Commissioner") must, with the aid of the County Attorney when necessary, determine on a case by case basis the applicability of EO #18 to a given project. In order for a project to be subject to EO #18, the Commissioner must make the following findings:

1. **Location:** The Commissioner must find that work on a project will take place solely within the geographic boundaries of Erie County.
2. **Monetary Threshold:** The Commissioner must find that the cost of a project meets or exceeds \$250,000. In determining whether a project meets the expenditure threshold of \$250,000, the Commissioner shall calculate the total cost of the project based on the successful bidder's final bid submission. A project previously exempt because it did not meet the monetary threshold of \$250,000 may become subject to EO #18 because an

amendment, modification, renewal, or extension increases the total cost of the project. In that case, the Commissioner will have the authority to unilaterally amend the project contract(s) to include the standard EO #18 contract language and certification specifically delineated below.

3. **Work Force Threshold:** The Commissioner must find that no less than three construction workers will be utilized by contractor and/or subcontractor for the completion of the project. In determining whether a project utilizes at least three construction workers to complete the Project, the Commissioner shall rely on the statement of work force contained within the attestation required by the mandatory request for bid language specifically delineated below. A project previously exempt because it did not meet the work force threshold may become subject to EO #18 because of an increase in work force during the course of work on the project. In that case, the Commissioner shall have the authority to unilaterally amend the project contract(s) to include the standard EO #18 contract language and certification specifically delineated below.

#### REQUEST FOR BID LANGUAGE

The Commissioner shall include the following language in all construction project Requests for Bids.

**ERIE COUNTY EXECUTIVE ORDER #18:** The project contemplated by this Request for Bids may be subject to Erie County Executive Order #18 which is attached hereto along with its Rules and Regulations for reference as Exhibit Section 00 73 40 Articles 1 and 2. The Erie County Department or Division letting the contract will advise the successful bidder if it must comply with Executive Order #18 at the time of award. All bids must include a verified attestation of intent to comply and statement of work force. Such attestation and statement is attached hereto as Exhibit Section 00 73 40 Article 3. Any bids received which do not include such attestation or include an incomplete attestation may be deemed non-responsive. Be advised that the Contractor will be required to provide monthly reports demonstrating good faith efforts to meet the work force goals using LCPTracker software.

#### Contract Language

The Commissioner shall include the following language in all award contracts for construction projects determined to be subject to EO #18.

**ERIE COUNTY EXECUTIVE ORDER #18:** The Commissioner or Division Director of the Erie County Department or Division letting the contract has determined that the project contemplated herein is subject to the provisions of Erie County Executive Order #18 which is attached hereto for reference as Exhibit Section 00 73 40 Articles 1 and 2. Prior to the final execution of this Agreement, Contractor shall furnish to the County a fully executed and verified Local and Disadvantaged Worker Compliance Certification. A fillable Certification is attached hereto as Exhibit Section 00 73 40 Article 3. Contractor will be required to provide monthly reports demonstrating good faith efforts to meet the work force goals using LCPTracker software. Contractor shall make such records as deemed necessary available upon request to the Erie County Division of Equal Employment Opportunity for review. The County shall have the right, upon reasonable notice and at reasonable times, to inspect the books and records of the Contractor, for the purpose of verifying information supplied in the Local and Disadvantaged Worker Compliance Certification and for any other purpose reasonably related to confirming Contractor compliance with Erie County Executive Order #18. Notwithstanding any other termination provisions contained herein, violations of the provisions of Executive Order #18 will constitute grounds for immediate termination of the underlying contract and shall further result in the Contractor being deemed



a non-responsible bidder for a period of twelve months. Once grounds for immediate termination are established, actual contract termination will be at the discretion of Erie County.

#### WAIVER PROCESS

When a Commissioner determines that a project is subject to the provisions of EO #18, he/she shall notify the successful bidder of such determination at the time of award. The successful bidder shall then have the opportunity to submit a partial waiver request to the Erie County Division of Equal Employment Opportunity for consideration. Waiver requests shall be made in writing and directed to the Erie County Division of Equal Employment Opportunity at 95 Franklin Street, Room 625, Buffalo, NY 14202 "Attention Director". In order to prevent undue project delays, any such request shall be made as soon as the successful bidder is aware that it cannot meet the full requirements of EO #18. Should a partial waiver be requested such request shall state which EO #18 requirement(s) cannot be met and shall further indicate how the successful bidder intends to partially comply. All waiver requests shall contain a narrative of the efforts employed by the successful bidder in attempting to comply with EO #18 by recruiting construction workers to work on the subject project and the reasons why such efforts were only partially successful. At a minimum, these efforts must include and the narrative must state the following:

- 1) Where a successful bidder has, through collective bargaining agreements or other legally binding agreements, any exclusive hiring arrangements with local unions such successful bidder must attempt to meet the mandates of EO #18 by following the hiring process outlined in their respective exclusivity agreements. The narrative provided in connection with any waiver request will describe the process followed and the results of those efforts. Where a successful bidder has no exclusive hiring agreements in place or where a successful bidder is unable to comply with EO #18 after following their exclusive hire process, such successful bidder must proceed to follow steps 2 through 4 below.
- 2) Posting the job opening(s) for construction worker(s) on or with each of the following:
  - A) The New York State Department of Labor Database used by the Buffalo and Erie County Workforce System ([www.jobzone.ny.gov](http://www.jobzone.ny.gov))
  - B) The People United for Sustainable Housing located at 271 Grant Street, Buffalo, NY 14213
  - C) At least one private staffing firm to aid Contractor in locating qualified candidates
  - D) Any other staffing organization or web site if so directed by the Erie County Commissioner of Public Works
- 3) All job opening(s) posted pursuant to Section one above must be posted for a period of at least ten (10) consecutive calendar days. Proof of publication must be included in all waiver requests.
- 4) The narrative provided with a waiver request shall state the number of candidates found via the job postings that would aid Contractor in meeting the requirements of EO #18, the number of those candidates that were subsequently interviewed for the opening(s), and if such candidates were not hired, the narrative shall include the reason(s) why the candidates were found to be unsuitable for the position(s).
- 5) A copy of the waiver request shall be sent to the Project Manager/Point of Contact in the Erie County Department of Public Works located at 95 Franklin Street, 14<sup>th</sup> Floor, Buffalo, NY 14202

If the Erie County Division of Equal Employment Opportunity determines that a successful bidder has demonstrated a good faith effort to comply in whole with the provisions of EO #18, and yet for reasons delineated in its request still cannot do so, a partial waiver shall be granted to the successful bidder.

## SPECIALIZED WORK EXEMPTION

Certain Erie County Construction Projects require the use of workers who possess specialized skills, training, or formal certification/licensing in order to complete the contemplated work. When a Commissioner or Director of an Erie County Department or Division believes that there are an insufficient number of construction workers that meet EO#18 requirements and possess the unique qualifications necessary to complete such specialized work, he/she may request a specialized work exemption from the Erie County Division of Equal Employment Opportunity. Where granted, a specialized work exemption removes the mandates of EO #18 in whole or in part for a given project.

A request for a specialized work exemption shall be made in writing by the commissioner or director bidding the subject project. The request shall be directed to the Erie County Division of Equal Employment Opportunity at 95 Franklin Street, Room 625, Buffalo, NY 14202 "Attention Director" and must include a narrative describing what the specialized work involves, what portion of the project such specialized work is needed for, the particular skills, training, or formal certification/licensing needed to perform the work, and the steps taken to determine if workers meeting EO #18 requirements have the necessary expertise. Upon receipt of a specialized work exemption request, the Equal Employment Opportunity Director shall form an ad hoc committee, and select its members, in order to review the request and either grant or deny the specialized work exemption.

The specialized work exemption committee shall consist of four members to include the commissioner or director of the department or division bidding the project, the involved project manager, and one respective representative from the Erie County Department of Law and the Erie County Division of Equal Employment Opportunity. The committee shall convene as soon as practicable to consider the specialized work exemption request. In making a determination, the committee shall consider all information presented to it and shall solicit further information from any source available in order to aid in its deliberations. A determination as to whether or not to grant the specialized work exemption shall be made within a reasonable time so as not to frustrate the bidding process for the contemplated project. The committee's determination shall be memorialized in writing and shall include its specific findings and the information upon which such findings were made.

Where the committee finds that a specialized work exemption is warranted, a notice to bidders shall be included in the project bid specifications which shall clearly indicate what portion of the project is exempt from the provisions of EO #18 and shall further indicate that the remaining work, if any, may still be subject to EO #18. Where there is work remaining outside of the granted exemption, the attestation of work force must be completed to include that portion of work which falls outside of the exemption.

## COMPLIANCE

The Director of the Erie County Division of Equal Employment Opportunity shall ensure that all contractors and subcontractors working on a Project as defined herein are in compliance with EO #18 or are in compliance with the provisions of any duly granted partial waiver or have been granted a full waiver.

## PENALTY FOR NONCOMPLIANCE

Any failure to adhere to Erie County Executive Order #18 or the Rules and Regulations contained herein shall cause Contractor to be deemed noncompliant. Such noncompliance shall constitute grounds for immediate termination of the underlying contract and shall further result in the Contractor being deemed a non-responsible bidder for a period of twelve months. Once grounds for immediate termination are established, actual contract termination will be at the discretion of Erie County.

**First Source Policy Targeted Zip Codes – Erie County Zip Codes with 20% Poverty Rate or Higher:**

<b>Zip Code</b>	<b>Area</b>
14201	Buffalo – Peace Bridge to Chippewa
14203	Buffalo – Downtown and the Outer Harbor
14204	Buffalo – Fruit Belt to the Old First Ward
14206	Cheektowaga
14207	Buffalo
14208	Buffalo
14209	Buffalo
14210	Buffalo
14211	Buffalo, Cheektowaga and Sloan – Kensington and Bailey
14212	Buffalo and Cheektowaga – Central Terminal and Broadway
14213	Buffalo – Peace Bridge to Buffalo State
14214	Buffalo – Delaware Park to UB (East Side)
14215	Buffalo and Cheektowaga – Intersection of Bailey Ave. and Route 33
14218	City of Lackawanna
14061	Farnham
14169	Wales Center

**ARTICLE 3 – EXECUTIVE ORDER NO. 18 FORMS**

Bound following this page are the following which are part of the Contract Documents:

1. Erie County Executive Order No. 18 Attestation and Statement of Workforce **(SUBMIT WITH BID)**
2. Erie County Local and Disadvantaged Worker Certification **(SUBMIT WITH AGREEMENT)**
3. Executive Order No. 18 Erie County Local and Disadvantaged Worker Compliance Certification – Waiver Request

SUBMIT WITH BID

**ERIE COUNTY EXECUTIVE ORDER #18  
ATTESTATION AND STATEMENT OF WORKFORCE**

We hereby attest that we have read and understand Erie County Executive Order #18 ("EO #18"). We acknowledge that the project we are bidding on may be subject to the provisions thereof. We further attest that, should we be identified as the successful bidder and should the appropriate individual or entity determine that this project is subject to EO #18, we will be in compliance with such Order, or we will have been granted a partial waiver by the Erie County Office of Equal Employment Opportunity.

We further acknowledge that in order for Erie County to determine if the project we are bidding on is subject to EO #18, they need to analyze the workforce that we intend to use on such project. For purposes of this attestation we understand that construction worker shall mean a laborer, workman, or mechanic who is directly involved in the construction, reconstruction, improvement, rehabilitation, installation, alteration, renovation, demolition or otherwise providing for any building, facility, roads, highways, bridges, or physical structure of any kind, but does not include professional services employees.

We therefore now do attest that it is our current intention to use the following number of construction workers, which number includes any subcontracted construction workers, on this project should it be awarded to us:

**Place an 'x' in only one box:**

Three (3) or more construction workers

Less than three (3) construction workers

  
\_\_\_\_\_  
Signature

**Verification**

STATE OF NEW YORK        )  
COUNTY OF ERIE         ) SS:

A) \_\_\_\_\_, being duly sworn, states he or she is the owner of (or partner in) \_\_\_\_\_, and is making the foregoing Attestation and Statement of Workforce and that such representations made are true to his or her own knowledge.

B) David Visone, being duly sworn, states that he or she is the (Name of Corporate Officer) President, of (Name of Corporation or Enterprise) Visone Construction Inc that he or she has read the Attestation and Statement of Workforce and that such representations made are true to his or her knowledge, and are made at the direction of the Board of Directors of the Corporation.

Sworn to before me this 11  
Day of January, 20 24

  
\_\_\_\_\_  
Notary Public

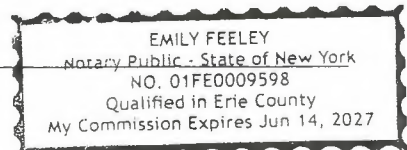



ERIE COUNTY LOCAL AND DISADVANTAGED  
WORKER COMPLIANCE CERTIFICATION

In order to comply with Erie County Executive Order #18 dated September 27, 2017 we hereby make the following certification:

1) We hereby certify that, including any and all subcontracted work hours used on the project, we are in full compliance with Erie County Executive Order #18.

OR,

2) We hereby certify that on \_\_\_\_\_, \_\_\_\_\_ we submitted a partial waiver request to the Erie County Office of Equal Employment Opportunity. Such request for partial waiver was granted on \_\_\_\_\_, \_\_\_\_\_. The conditions granted to us under this partial waiver allow for \_\_\_\_\_

We further certify that we are in compliance with all conditions granted to us under this partial waiver.

We understand that this certification is a material component of this contract. Violation of the provisions of Executive Order #18 will constitute grounds for the immediate termination of this Agreement and will further result in the Contractor being deemed a non-responsible bidder for a period of twelve months. Once grounds for immediate termination are established, actual contract termination will be at the discretion of Erie County.

[Signature]  
Signature

Verification

STATE OF NEW YORK )  
COUNTY OF ERIE ) SS:

A) \_\_\_\_\_, being duly sworn, states he or she is the owner of (or partner in) \_\_\_\_\_, and is making the foregoing Attestation and Statement of Workforce and that such representations made are true to his or her own knowledge.

B) David Visone, being duly sworn, states that he or she is the (Name of Corporate Officer) President, of (Name of Corporation or Enterprise) Visone Construction Inc. that he or she has read the Attestation and Statement of Workforce and that such representations made are true to his or her knowledge, and are made at the direction of the Board of Directors of the Corporation.

Sworn to before me this 11  
Day of January, 2024

[Signature]  
Notary Public

EMILY FEELEY  
Notary Public - State of New York  
NO. 01FE009598  
Qualified in Erie County  
My Commission Expires Jun 14, 2027

SUBMIT WITH AGREEMENT

EXECUTIVE ORDER NO. 18  
ERIE COUNTY LOCAL AND DISADVANTAGED  
WORKER COMPLIANCE CERTIFICATION – WAIVER REQUEST

COMPANY: Vision Construction, Inc  
PROJECT NAME: E.O. NO 1,234,5678  
PROJECT NUMBER: 96  
ADDRESS / PHONE: 79 Sheldon Ave, Piquette, NY 14043

**Waiver Request Requirements are as follows:**

1. Contractor has made a good faith effort to meet the requirements of Executive Order No. 18.
2. This waiver request form is to be accompanied with a detailed description of reasons to grant the waiver request on company letterhead per the requirements included in the Rules and Regulations "Waiver Process".
3. In the event Contractor is seeking a waiver due to **workforce** challenges, Contractor must provide proof of the following:
  - a. Job postings per the Rules and Regulations and a description of candidate responses; and/or
  - b. A copy of the company's collective bargaining or other legally binding agreement(s) (i.e. union signatory agreements or exclusivity agreements, etc.) and a description of how Contractor attempted to meet E.O. 18 requirements via this hiring process.
4. In the event Contractor is seeking a waiver due to **specialized work**, Contractor must provide a description of the specialized work, the particular skills and/or licenses required to complete such work and the reasons why a waiver is needed.
5. If a partial waiver is granted, Contractor is required to be in full compliance with the adjusted requirements.

A waiver provided for Executive Order No. 18, is hereby requested on the grounds that we have met the job posting requirements of the waiver process and are seeking a reduction of the following workforce requirements:

<u>Percentage Required</u>	<u>Percentage Requested</u>
Local Labor (100%):	_____
Erie County (70%):	_____
Disadvantaged (30%):	_____

-OR-

A waiver provided for Executive Order No. 18, is hereby requested due to the nature of specialized work and the revised dollar amounts of the contract are proposed to be as follows:

Original Awarded Contract Value: \$ \_\_\_\_\_

Proposed Decrease in Contract Value subject to EO 18 requirements: \$ \_\_\_\_\_  
(if requesting partial waiver)

Revised Contract Value subject to EO 18 requirements: \$ \_\_\_\_\_

[Signature]  
SIGNATURE OF AUTHORIZED REPRESENTATIVE

1-11-24  
DATE

**FOR ERIE COUNTY APPROVAL:**

\_\_\_\_\_  
Office of Equal Employment Opportunity

\_\_\_\_\_  
Erie County Department Representative

# Acknowledgement of Wage Schedule Receipt

(SUBMIT WITH BID)

By signing this form, the Bidder acknowledges the following:

1. The County of Erie, Department of Environment and Planning, Division of Sewerage Management has provided a PRC# specific to this Project.
2. By following the link provided in electronic documents or by typing the PRC# provided in Section 00 73 43 Wage Rate Requirements, under Article 1.02, into the New York State Department of Labor Project Prevailing Wage Website at <https://apps.labor.ny.gov/wpp/showFindProject.do?method=showIt>, the Bidder has obtained the complete schedule of wages specific to this Project.
3. The Bidder has reviewed Section 00 73 43, the project rate schedule provided by the New York State Department of Labor, and all associated documents, and understands their responsibilities related to these documents if they are selected to perform this Project.

Project Name: Erie County Sewer District No. 1, 2, 3, 4, 5, 6, 7 & 8

Contract: 96

Company Name: Visone Construction, Inc

Company Address: 79 Sheldon Ave Depew, NY 14043

Signature: [Handwritten Signature]

Written Name: David Visone

### PRIME CONTRACTOR AFFIDAVIT

According to the best of my knowledge, I certify that all the following statements are true and accurate and are made under penalty of perjury:

- I agree to comply with Executive order 11246, New York State (NYS) Article 15-A of the Executive Law, and Erie County Local Law No. 6-1987 & 5-1994 to achieve Minority and Women Business Enterprise goals assigned to this contract.
- I agree to comply with Service-Disabled Veterans Utilization Local Law No. 5-1, 2023.
- I understand that only NYS or Erie County/City of Buffalo certified MBE & WBE owned and operated business enterprises will be credited towards fulfillment of the MBE & WBE utilization goals on this construction project.
- I understand that only NYS certified SDVOB enterprises will be credited towards the fulfillment of the SDVOB goals on this construction project.
- I will make every good faith effort to meet the MBE, WBE, and SDVOB utilization goals in which contained in the contract.
- I affirm that I have no direct or indirect control over any MBE, WBE, or SDVOB which I propose to use in fulfillment of the MBE, WBE, or SDVOB utilization goals of this contract.
- I understand that I will not meet the MBE, WBE, or SDVOB goal through arrangements with minority, female, or service-disabled veteran individuals of firms, which are not certified as participating minority, woman, or service-disabled veteran owned business enterprises.
- I understand and acknowledge that I will not perform any services and functions to such an extent that the MBE, WBE or SDVOB owner/operator does not manage and control its company
- I will only utilize MBE, WBE, and SDVOB subcontractors and/or suppliers certified as stated above.
- I understand that I am responsible for ensuring that MBE, WBE, and SDVOB firms are utilized in order to further utilization goals. I understand that failure to utilize MBE, WBE, and SDVOB firms are represented herein, will constitute a material breach of contract.
- The MBE, WBE or SDVOB firm will perform all the work and/or supply all the material covered under the prime contractor and subcontractor agreement. If a change occurs, it is the prime contractor's responsibility to notify Erie County-EEO Office within 2 weeks.
- I understand that I will not withhold any payments that I agree on with MBE, WBE or SDVOB upon completion of the project.
- I understand that any misrepresentation of fact in this affidavit may lead to criminal prosecution under State and Federal law.
- The percentage (%) of MBE utilization goal for this contract is 10%
- The percentage (%) of WBE utilization goal for this contract is 2%.
- The percentage (%) of SDVOB utilization goal for this contract is 6%.

1/11/24  
Date

Viscore Construction Inc  
Name of Company

79 Sheldon Ave, Depew, NY 14043  
Address

716-681-7331  
Telephone No.

[Signature]  
Authorized Signature

Sworn to me this 11 day of January 20 24

[Signature]  
Signature of Notary

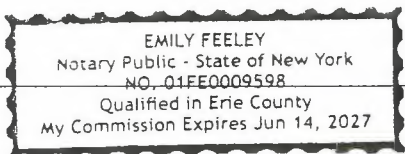



**WE ARE YOUR DOL**



www.labor.ny.gov

*Approved*

**Apprentice Training Program Registration Agreement**

Revision

Nature of Change: Recertification  
Wage Update

State Use Only	
AT Sponsor No.	<u>77987</u>
ATP Code	<u>18-285</u>
Effective Date of AT Program	<u>11/18/2015</u>

- Name of Sponsor: Visone Construction, Inc.
- Mailing Address: 79 Sheldon Ave. Depew NY 14043 Erie  
(number & street) (city) (state) (zip code) (county)
- Actual Address: same  
(number & street) (city) (state) (zip code) (county)
- Telephone No.: (716) 681-7331 Ext. \_\_\_\_\_ Fax No.: (716)v681-7876
- E-mail Address: lori@visoneconstruction.com
- Trade/Occupation: Operating Engineer (universal equipment)
- No. Employees: 23 No. Apprentices: 1 No. Journeyworkers: 15 8. Ratio: 1:1:1:5
- DOT Code: 859-683-010 10. Length of Program: 36 months
- Apprentice Probationary Period: 9 months 12. Work process: Standard  or Revised
- Minimum Journeyworker Rate: \$ 28 per hour 14. Effective Date of Wages: 7/1/2022

15. Apprentice wage progression for each period – in months (M) or hours (H)

1	2	3	4	5	6	7	8	9	10
M <input type="checkbox"/>	M <input type="checkbox"/>	M <input type="checkbox"/>	M <input type="checkbox"/>	M <input type="checkbox"/>	M <input type="checkbox"/>	M <input type="checkbox"/>	M <input type="checkbox"/>	M <input type="checkbox"/>	M <input type="checkbox"/>
H <input checked="" type="checkbox"/>	H <input checked="" type="checkbox"/>	H <input checked="" type="checkbox"/>	H <input checked="" type="checkbox"/>	H <input checked="" type="checkbox"/>	H <input checked="" type="checkbox"/>	H <input checked="" type="checkbox"/>	H <input checked="" type="checkbox"/>	H <input checked="" type="checkbox"/>	H <input checked="" type="checkbox"/>
55%	60%	65%	70%	75%	80%	90%	95%		

16. The sponsor agrees to comply with the provisions on this side and on the reverse of this agreement.

17. [Signature] 4-11-23 18. \_\_\_\_\_  
 Signature of Official Sponsor Representative Date Signature of Union Representative Date  
Dave Visone Sponsor \_\_\_\_\_  
 Print Name and Title Print Name, Title, and Union Name

19. \_\_\_\_\_ Date  
 Signature New York State Department of Labor

*correct*

## Provisions for Agreements

1. The Sponsor agrees that apprentices shall be hired without any direct or indirect limitation, specification or discrimination as to race, color, religion, national origin, sex, disability, marital status, age, arrest record, or veteran status.
2. If the Sponsor grants advance credit or standing for previously acquired experience or training, the Sponsor agrees to apply the same evaluation method uniformly for all apprentices.
3. The Sponsor agrees to post, in a conspicuous place, a copy of the Regulation (600. 12) dealing with the Equal Employment Opportunity complaint procedure, and to bring its provisions to the attention of all apprentices.
4. The Sponsor agrees to follow and comply with the approved Work Progress, the Equal Employment Opportunity in Apprenticeship Training Part 600 Regulations, and the Regulations Governing the Registration of Apprenticeship Programs and Agreements, Part 601.
5. The Sponsor agrees to provide competent supervision of worksite training and adequate facilities to train apprentices.
6. The Sponsor agrees to instruct apprentices in safe and healthful work practices and agrees to ensure that training is provided in facilities and other environments that are in compliance with the safety and health standards promulgated by the Secretary of Labor under Public Law 91-596, and the Public Employees Safety and Health Act of the New York State Labor Law Article 2; Section 27-A.
7. The Sponsor agrees to evaluate the progress of all apprentices at least every six months, including job performance.
8. The Sponsor agrees to pay all apprentices a progressively increasing scale of wages as indicated on the front side of this form.
9. The Sponsor agrees to pay no less than the minimum journeyworker rate to each apprentice who completes the apprentice program and becomes eligible to receive a state Certificate of Completion.
10. The Sponsor recognizes that prevailing wage rates for Public Work projects are set by designated government agencies and the wages listed in this program do not supersede or replace the wage rates set by those agencies.
11. The Sponsor agrees that the Department of Labor may recognize successful completions of apprenticeships by awarding State Certifications of Completion and agrees to accept presentation of the certificate as documentation of journeyworker status.
12. The Sponsor agrees to maintain records for each apprentice including but not limited to: job assignments, promotion, demotion, lay-offs, terminations, rates of pay, progress in training as outlined on the Work Processes, any other records pertinent to a determination of compliance with Article 23 of the Labor Law and in compliance with Apprenticeship Regulations, Part 600 and 601.
13. The Sponsor agrees to promptly record, maintain and submit to the Department of Labor all records concerning apprenticeship as may be required by the Department of Labor.
14. The Sponsor agrees that all program modifications, revisions or reports will be submitted to the Department of Labor within 30 calendar days of such program change or the report request.
15. The Sponsor agrees to promptly notify the Department of Labor of all apprentices who have successfully completed an apprenticeship program.
16. The Sponsor agrees not to subvert the program by hiring workers as helpers, shophands, or other titles and assigning to them work generally performed by apprentices.
17. The Sponsor recognizes that, if it is without an apprentice for a period of twelve months, that the program will be deemed deregistered unless it has been granted Inactive Status or is a program operated by a NYS agency.
18. The Sponsor agrees to comply with, and hold all signatories to, the standards in this Apprenticeship Training Program Registration Agreement.
19. The Sponsor agrees to ensure that each of their apprentices will maintain a record that documents task rotation and the skills acquired through the program in a format that is approved by the Department of Labor. The apprentice's Blue Book is considered an acceptable format.

**WE ARE YOUR DOL**



www.labor.ny.gov

*LALB...*

**Apprentice Training Program Registration Agreement**

Revision

Nature of Change: Recertification  
Wage Update

State Use Only	
AT Sponsor No.	<u>77-987</u>
ATP Code	<u>18-514</u>
Effective Date of AT Program	<u>07/09/2004</u>

- Name of Sponsor: Visone Construction, Inc.
- Mailing Address: 79 Sheldon Avenue Depew NY 14043 Erie  
(number & street) (city) (state) (zip code) (county)
- Actual Address: 79 Sheldon Avenue Depew NY 14043 Erie  
(number & street) (city) (state) (zip code) (county)
- Telephone No.: 716-681-7331 Ext. \_\_\_\_\_ Fax No.: 716-681-7876
- E-mail Address: Lori@visoneconstruction.com
- Trade/Occupation: Skilled Construction Craft Laborer
- No. Employees: 23 No. Apprentices: 2 No. Journeyworkers: 15 8. Ratio: 1:1:1:3
- DOT Code: 869-463.580 10. Length of Program: 24 months
- Apprentice Probationary Period: 6 months 12. Work process: Standard  or Revised
- Minimum Journeyworker Rate: \$ 26.00 per hour 14. Effective Date of Wages: 07/1/2022

15. Apprentice wage progression for each period – in months (M) or hours (H)

1	2	3	4	5	6	7	8	9	10
M <input type="checkbox"/>	M <input type="checkbox"/>	M <input type="checkbox"/>	M <input type="checkbox"/>	M <input type="checkbox"/>	M <input type="checkbox"/>	M <input type="checkbox"/>	M <input type="checkbox"/>	M <input type="checkbox"/>	M <input type="checkbox"/>
H <input checked="" type="checkbox"/>	H <input checked="" type="checkbox"/>	H <input checked="" type="checkbox"/>	H <input checked="" type="checkbox"/>	H <input checked="" type="checkbox"/>	H <input checked="" type="checkbox"/>	H <input checked="" type="checkbox"/>	H <input type="checkbox"/>	H <input type="checkbox"/>	H <input type="checkbox"/>
0-500	1000	1500	2000	2500	3000	4000			
55%	60%	65%	70%	75%	80%	90%			

16. The sponsor agrees to comply with the provisions on this side and on the reverse of this agreement.

17. [Signature] 4-11-23 18. \_\_\_\_\_  
 Signature of Official Sponsor Representative Date Signature of Union Representative Date  
Dan Visone Sponsor \_\_\_\_\_  
 Print Name and Title Print Name, Title, and Union Name

19. \_\_\_\_\_  
 Signature New York State Department of Labor Date

*Updated - corrected*

## Provisions for Agreements

1. The Sponsor agrees that apprentices shall be hired without any direct or indirect limitation, specification or discrimination as to race, color, religion, national origin, sex, disability, marital status, age, arrest record, or veteran status.
2. If the Sponsor grants advance credit or standing for previously acquired experience or training, the Sponsor agrees to apply the same evaluation method uniformly for all apprentices.
3. The Sponsor agrees to post, in a conspicuous place, a copy of the Regulation (600. 12) dealing with the Equal Employment Opportunity complaint procedure, and to bring its provisions to the attention of all apprentices.
4. The Sponsor agrees to follow and comply with the approved Work Progress, the Equal Employment Opportunity in Apprenticeship Training Part 600 Regulations, and the Regulations Governing the Registration of Apprenticeship Programs and Agreements, Part 601.
5. The Sponsor agrees to provide competent supervision of worksite training and adequate facilities to train apprentices.
6. The Sponsor agrees to instruct apprentices in safe and healthful work practices and agrees to ensure that training is provided in facilities and other environments that are in compliance with the safety and health standards promulgated by the Secretary of Labor under Public Law 91-596, and the Public Employees Safety and Health Act of the New York State Labor Law Article 2; Section 27-A.
7. The Sponsor agrees to evaluate the progress of all apprentices at least every six months, including job performance.
8. The Sponsor agrees to pay all apprentices a progressively increasing scale of wages as indicated on the front side of this form.
9. The Sponsor agrees to pay no less than the minimum journeyworker rate to each apprentice who completes the apprentice program and becomes eligible to receive a state Certificate of Completion.
10. The Sponsor recognizes that prevailing wage rates for Public Work projects are set by designated government agencies and the wages listed in this program do not supersede or replace the wage rates set by those agencies.
11. The Sponsor agrees that the Department of Labor may recognize successful completions of apprenticeships by awarding State Certifications of Completion and agrees to accept presentation of the certificate as documentation of journeyworker status.
12. The Sponsor agrees to maintain records for each apprentice including but not limited to: job assignments, promotion, demotion, lay-offs, terminations, rates of pay, progress in training as outlined on the Work Processes, any other records pertinent to a determination of compliance with Article 23 of the Labor Law and in compliance with Apprenticeship Regulations, Part 600 and 601.
13. The Sponsor agrees to promptly record, maintain and submit to the Department of Labor all records concerning apprenticeship as may be required by the Department of Labor.
14. The Sponsor agrees that all program modifications, revisions or reports will be submitted to the Department of Labor within 30 calendar days of such program change or the report request.
15. The Sponsor agrees to promptly notify the Department of Labor of all apprentices who have successfully completed an apprenticeship program.
16. The Sponsor agrees not to subvert the program by hiring workers as helpers, shophands, or other titles and assigning to them work generally performed by apprentices.
17. The Sponsor recognizes that, if it is without an apprentice for a period of twelve months, that the program will be deemed deregistered unless it has been granted Inactive Status or is a program operated by a NYS agency.
18. The Sponsor agrees to comply with, and hold all signatories to, the standards in this Apprenticeship Training Program Registration Agreement.
19. The Sponsor agrees to ensure that each of their apprentices will maintain a record that documents task rotation and the skills acquired through the program in a format that is approved by the Department of Labor. The apprentice's Blue Book is considered an acceptable format.

**Section 00 73 43**  
**Wage Rate Requirements**

The following are wage rate requirements for the Project. This Section is part of the Contract Documents.

	Page
Article 1 -Hours and Wages.....	2
Article 2 – Posting Minimum Wage Rates.....	2
Article 3 – Payroll Records.....	3
Article 4 – Apprentices.....	3
Article 5 – Computation of Wages on Eight Hour Day: Overtime Compensation.....	4
Article 6 – Payment of Employees.....	4
Article 7 – Wage Rate Forms.....	4

FORMS:

Acknowledgement of Wage Schedule Receipt (SUBMIT WITH BID)

## **ARTICLE 1—HOURS AND WAGES**

- 1.01. No laborer, worker, or mechanic in the employ of Contractor, Subcontractor or other person doing or contracting to do the whole or part of the Work contemplated by this Contract shall be permitted or required to work more than eight hours in any one calendar day or more than five days in any one week except in case of extra-ordinary emergency as described in Section 220(2) of the New York State Labor Law. For work in excess of eight hours in any one day or five days in any one-calendar week an "Application for Dispensation of Hours" (Form PW-30) must be submitted and approved by Erie County and the State Department of Labor.
- 1.02. The wages and supplements to be paid to laborers, workers or mechanics performing the Work under this Contract shall be not less than the prevailing rate of wages and supplements as defined and determined by the New York State Labor Law. On projects involving both State and Federal agencies, Contractor shall obtain the Federal Wage rates and apply the higher rate for the trade or occupation. The prevailing rate of wages for New York State can be found at **PRC #2023012974**. Contractor is responsible for all modifications to the prevailing wage rates that may occur during the course of the Contract.
- 1.03. There shall be paid each laborer or mechanic of Contractor or Subcontractor engaged in the Work on the Project under this Contract in trade or occupation listed below, not less than the hourly wage rate set opposite the same, regardless of any contractual relationship which may be alleged to exist between the Contractor or any Subcontractor and such laborers and mechanics.
- 1.04. Any laborer or mechanic employed to perform work on the Project under this Contract, which work is not covered by any of the classifications, of the various State and Federal agencies, shall be paid not less than the minimum rate of wages specified herein for the classification which most nearly corresponds to work to be performed by them and such minimum wage rate shall be retroactive to the time of initial employment of such person in such classification. In the event any dispute on that question cannot be adjusted, the information, together with the recommendations of Engineer or its other authorized representatives, shall be referred for determination to Owner's governing body or other duly designated official whose decision on the question shall be conclusive on the parties to the Contract with the same effect as if the Work performed by such laborer or mechanic had been classified and the minimum rate specified herein.
- 1.05. The foregoing specified wage rates are minimum rates only. Owner will not consider any claims for additional compensation made by Contractor because of payment by Contractor of any wage rate in excess of the applicable rates contained in this Contract. All disputes in regard to the payment of wages in excess of those specified in this Contract shall be adjusted and resolved by Contractor.
- 1.06. Except as may be otherwise required by law, all claims and disputes pertaining to the classification of labor employed on the project under this Contract shall be decided by Owner's governing body or other duly designated officials, or the New York State Department of Labor.

## **ARTICLE 2—POSTING MINIMUM WAGE RATES**

- 2.01 Contractor shall post at appropriate conspicuous points at the Site of the Project a schedule showing all determined minimum wage rates for the various classes of laborers and mechanics to be engaged in the Work on the Project under this Contract and all deductions, if any, required by law to be made from unpaid wages actually earned by the laborers and mechanics so engaged.

The wage rates shall be posted on a sign written in English with a bold heading stating "Prevailing Rate of Wages". The lettering of the heading shall be no smaller than 2" in height and 2" in width and the entire sign shall be weatherproof. On projects involving both State and Federal agencies Contractor may be required to post both State and Federal Wage Rates, the higher of which shall apply in any classification.

### **ARTICLE 3—PAYROLL RECORDS**

- 3.01. Contractor and all Subcontractors will be required to furnish to Engineer duplicate copies of all payrolls incurred as a result of work on the Project. Payrolls are to be submitted on U.S. Department of Labor Payroll Form WH-347, signed by an officer of the company, no later than three days after the close of any payroll period and not in any case later than Contractor's monthly payment estimate. Prime Contractors are required to submit certified payrolls from the issuance of the Notice to Proceed until contract close out. Negative reports shall be submitted for times when no actual work is being performed. Subcontractors are required to submit certified payrolls for only the time spent on the project.
- 3.02. The name of the individual designated by Contractor as the person responsible to collect certified payroll shall be posted in a conspicuous location at the Site.
- 3.03. The filing of certified payrolls is a condition of payment. A contractor that willfully fails to file certified payrolls shall be guilty of a Class "E" felony and subject to a civil penalty of up to \$1,000.00 per day.
- 3.04. Upon completion of the Work, Contractor shall be required to execute a Public Improvement Contract Certification for (PICC-2) certifying that the provisions of Section 220-a of the New York State Labor Law have been complied with and that all laborers, workers or mechanics employed by Contractor on this Project have been paid the applicable prevailing wage rates and supplements.
- 3.05. Upon completion of the Work, all Subcontractors to Contractor shall be required to execute a Public Improvement Contract Certification form (PICC-1) certifying that the provisions of Section 220-a of the New York State Labor Law have been complied with and that all laborers, workers or mechanics employed by Subcontractor for work done on this Project have been paid the applicable prevailing wage rates and supplements.
- 3.06. Final payment will not be issued until all forms have been properly executed by Contractor and Subcontractors.

### **ARTICLE 4—APPRENTICES**

- 4.01. The minimum wage rates, if any, herein specified, for apprentices, shall apply only to persons working with the tools of the trade they are learning under the direct supervision of journeymen mechanics. Except as otherwise required by law, the number of apprentices in each trade or occupation employed by the Contractor or any Subcontractor shall not exceed the number permitted by the applicable standards of the United States Department of Labor or in the absence of such standards, the number permitted under the usual practice prevailing between unions and the employer's associations of the respective trade of occupations.



## **ARTICLE 5—COMPUTATION OF WAGES ON EIGHT HOUR DAY: OVERTIME COMPENSATION**

- 5.01. The wages of each laborer and mechanic engaged in the Work on the Project under this Contract shall be computed on a basic day rate of 8 hours per day, 8 hours of continuous employment, except for lunch periods, constituting a days work when a single shift is employed, and 7 ½ hours of continuous employment except for lunch period constituting a days work when 2 or more shifts are employed. Work in excess of 8 hours per day shall be permitted upon compensation when a single shift is employed, at a minimum of 1 ½ times the basic rate of pay (i.e., the rate actually payable to the laborer or mechanic, which may be higher but not lower than the minimum wage set forth in the foregoing schedule) for all hours worked in excess of 8 hours, on any one day and when two or more shifts are employed, at a minimum of 1 ½ times the basic rate of pay for all ours worked in excess of 7 ½ hours on any one day. In addition, all laborers and mechanics shall receive compensation at a rate not less than 1 ½ times their basic rate of pay for all hours of work in excess of forty in one week when one shift is employed and all hours of work in excess of thirty-seven and one-half in one work week when two shifts are employed. The provisions of this article shall not limit agreements to the contrary, mandatory overtime compensation in excess of that stipulated herein and such extra compensation shall not constitute a claim for additional compensation under this Contract.

## **ARTICLE 6—PAYMENT OF EMPLOYEES**

- 6.01. Contractor and all Subcontractors shall comply with the Regulations of the Secretary of Labor made pursuant to the Anti-Kickback Act of June 30, 1940, 40 U.S.C. 276(c) and any amendments of modifications thereto. Contractor and all Subcontractors shall furnish Owner with weekly statements of compliance. In case of subcontracts, Contractor shall cause appropriate provision to be inserted in any subcontracts for work which they may let to insure compliance with said Anti-Kickback Law by all Subcontractors subject thereto, and Contractor shall be responsible for the submission of all statements of compliance required of Subcontractors by said Anti-Kickback Act except as the Secretary of Labor may specifically provide for reasonable limitations, variations, and exemptions from the requirements thereof.
- 6.02. Contractor and each of their Subcontractors shall pay each of their employees engaged in the Work on the Project wages in full not less often than once every other week, less legally required deductions. Records of such payment, deductions, and hours worked shall be provided each employee with each payment of wages.

## **ARTICLE 7—WAGE RATE FORMS**

Bound following this page are the following which are part of the Contract Documents:

1. Acknowledgement of Wage Schedule Receipt **(SUBMIT WITH BID)**

## Acknowledgement of Wage Schedule Receipt

(SUBMIT WITH BID)

By signing this form, the Bidder acknowledges the following:

1. The County of Erie, Department of Environment and Planning, Division of Sewerage Management has provided a PRC# specific to this Project.
2. By following the link provided in electronic documents or by typing the PRC# provided in Section 00 73 43 Wage Rate Requirements, under Article 1.02, into the New York State Department of Labor Project Prevailing Wage Website at <https://apps.labor.ny.gov/wpp/showFindProject.do?method=showIt> , the Bidder has obtained the complete schedule of wages specific to this Project.
3. The Bidder has reviewed Section 00 73 43, the project rate schedule provided by the New York State Department of Labor, and all associated documents, and understands their responsibilities related to these documents if they are selected to perform this Project.

Project Name: \_\_\_\_\_

Contract: \_\_\_\_\_

Company Name: \_\_\_\_\_

Company Address: \_\_\_\_\_

Signature: \_\_\_\_\_

Written Name: \_\_\_\_\_

## SECTION 00 73 75

### LOCAL AGENCY REQUIREMENTS

This Section details Local Law requirements for the Project that are not included in other Sections. This Section is part of the Contract Documents.

	Page
Article 1 – Erie County Local Law No. 2 – 2021.....	2
Article 2 – Local Law No. 2 – 2021 Forms (SUBMIT WITH BID).....	6

**ARTICLE 1 – ERIE COUNTY LOCAL LAW INTRO NO. 2 – 2021**

COUNTY OF ERIE  
LOCAL LAW NO. 2  
2021

A LOCAL LAW updating and reforming Erie County's Requirements for Lowest Responsible Bidding on County Construction Projects and Repealing and Replacing Local Law 1-2009 in its entirety.

BE IT ENACTED BY THE ERIE COUNTY LEGISLATURE AS FOLLOWS:

Section 1. Legislative Intent.

The Erie County Legislature hereby finds, declares and determines that:

- A. New York General Municipal Law Section 103 requires that all contracts entered into by the County of Erie for public work involving an expenditure of more than thirty-five thousand dollars (\$35,000) shall be awarded to the lowest responsible bidder.
- B. Taxpayers have a strong interest in an effective screening process to ensure that appropriate contractors be awarded public works contracts. A thorough evaluation process ensures that the taxpayers get a proper return on their investment and that qualified contractors are awarded bids.
- C. General Municipal Law § 103(15)(a) recognizes the need for this process and provides that municipalities, such as the County of Erie, may establish guidelines governing the qualifications of bidders seeking to bid or enter into such contracts.
- D. By enacting this Local Law, the County of Erie seeks to establish such guidelines in order to assure the prudent and economical use of public moneys for the benefit of all the inhabitants of the County.

Section 2. Short Title.

This Local Law shall be known as "the Erie County Lowest Responsible Bidder Law".

Section 3. Applicability.

This Local Law shall apply to County of Erie construction projects, defined herein, in excess of \$35,000 and advertised for bids on or after the effective date of this Local Law.

Section 4. Definitions.

- A. "The County of Erie" or "County" as used herein shall include the political subdivision known as the County of Erie as well as those County Departments responsible for letting public works contracts.
- B. "Bidder" or "bidders" as used herein shall include individuals, companies, partnerships or other entities that respond to requests for bids issued by the County of Erie.
- C. "Construction Projects" as used herein shall mean projects with a value in excess of

\$35,000 where the County of Erie is a direct or indirect party to the contract which includes more than an incidental amount of construction type activity intended to benefit the public, including all work which is necessary, incidental or connected with the execution of the contract which is performed by construction workers. A public entity need not be party to the construction contract. A construction contract includes: projects that the County of Erie funds directly, projects that the County of Erie funds indirectly by providing funds to a separate entity to perform the construction type activity; privately financed construction projects specifically built with the intent of leasing them to any Department of the County of Erie government; and construction projects built under the County of Erie's direction and later paid for with County of Erie funds.

D. "Commissioner" as used herein shall mean the Commissioner of the County of Erie Department that is requesting bids and/or his or her designee.

E. "Responsible" or "responsibility" as used herein means the financial ability, legal capacity, integrity, past performance of a business entity and compliance with applicable laws and regulations and as such terms have been interpreted relative to public procurements.

F. "Responsive" as used herein means a bidder meeting the minimum specifications or requirements as prescribed in the request for bids.

G. "Responsibility Questionnaire" shall mean the current the New York Vendor Responsibility Questionnaire For-Profit Construction (CCA-2), as maintained by the New York Office of the State Comptroller, and as may be amended from time to time, which requires all bidders to answer questions demonstrating their financial ability, legal capacity, integrity, past performance on municipal contracts and compliance with applicable laws and regulations. Such Questionnaire shall be affirmed by a principal of the bidder.

#### Section 5. Requirements.

A. By submitting bids in response to solicitations from the County of Erie, all bidders and sub-bidders (including sub-sub bidders) for construction projects funded by the County of Erie, acknowledge the terms and conditions of this Local Law and agree that they shall comply with the obligations of this Local Law.

B. In addition to the bid response, all bidders shall complete and submit a Responsibility Questionnaire as defined in Section 4 so that the County can evaluate the financial responsibility and organizational capacity of the bidder; the bidder's legal authority to do business in this County and State; the integrity of the owners, officers, principals, members and contract managers and the past performance of the bidder on prior municipal or public contracts. The completed Responsibility Questionnaire must be submitted with the bid.

C. Failure to submit the completed Responsibility Questionnaire with the bid documents shall render the bid non-responsive and the bid shall not be considered by the Commissioner.

#### Section 6. Procedure.

A. Bids for construction projects to which this Local Law applies shall be advertised in accordance with the requirements of the General Municipal Law and other applicable State and Local Laws. Such advertisement shall set forth the request for bids and shall set forth the deadline for submission and the time and place of the public opening of the bids.

B. The Commissioner, or his or her designee, shall distribute to all bidders a copy of this Local Law and the Responsibility Questionnaire referenced above. Distribution of the aforementioned documents shall be deemed effectuated when delivered in the same manner as the request for bids and any associated documents. The submission of a bid shall establish that the bidder received all necessary documents, including but not limited to, the Responsibility Questionnaire.

C. Only Bids accompanied by the Responsibility Questionnaire and all other necessary documentation will be considered by the Commissioner and or his or her designee.

D. All bids received shall be publicly opened and read at the time and place so specified in the advertisement for bids and the identity of all bidders shall be publicly disclosed at the time and place so specified. The apparent lowest bidder shall be announced at that time.

E. Commencing on the date of the bid opening and lasting for ten (10) calendar days thereafter, there shall be a public comment period during which members of the public may submit information relative to any such bidder to the Commissioner. The Commissioner shall acknowledge receipt of such information, and provide a written response prior to the final determination of bidder responsibility.

F. After review of the bid documents, the information collected pursuant to this and other Local Laws, New York State Law, applicable rules and regulations, consideration of the information provided in the Responsibility Questionnaire and of the financial ability, legal capacity, integrity, past performance of the bidder and compliance with applicable laws and regulations, the Commissioner shall determine if the apparent lowest bidder is responsible.

H. If the amount of the lowest responsible bidder appears disproportionately low when compared with estimates undertaken by or on behalf of the County of Erie, and/or compared to other bids submitted (10% or greater disparity), the County reserves the right to inquire further of the apparent lowest bidder to determine whether the bid contains mathematical errors, omissions and/or erroneous assumptions, and whether the apparent lowest bidder has the capability to perform and complete the contract for the bid amount.

I. If the apparent lowest bidder is deemed responsible by the Commissioner, such low bidder will be notified, as soon as is practicable.

J. At least five (5) business days prior to the award of the contract to the low bidder, the Commissioner shall post on the Erie County Website a listing of the three apparent lowest bidders for the work.

#### Section 7. Non-Responsibility Determination.

A. If, after review of the bid documents, the information collected pursuant to this and other Local Laws, New York State Law, applicable rules and regulations, consideration of the information provided in the Responsibility Questionnaire and of the financial ability, legal capacity, integrity, past performance of the bidder and compliance with applicable laws and regulations, the Commissioner makes a provisional determination that the apparent lowest bidder is deemed not to be responsible, the provisions of subdivisions C-E herein shall apply.

B. In the event the bidder is found to have falsified information on a submitted Responsibility Questionnaire or if the bidder fails to properly disclose information that would call into question the

financial ability, legal capacity, integrity, or past performance of the business entity, the Commissioner shall make a provisional determination that the bidder is not responsible subject to the provisions of subdivisions C-E herein.

C. Not less than five (5) business days prior to any final determination that the apparent lowest bidder is not responsible, the County shall notify the affected bidder of the same, in writing, stating the reasons therefore and setting forth a time, date and place for the apparent lowest bidder to appear and be heard on the issue of non-responsibility. Mailing via first class mail to the address provided by bidder shall constitute sufficient service of the notice.

D. At the date, time and place set forth above, the bidder may appear in person, with or without counsel or via affidavit. After due consideration, the Commissioner shall make a determination with regard to responsibility. Such determination may be appealed pursuant to the CPLR.

E. If the apparent lowest bidder is deemed not to be responsible; then the next lowest bidder will be reviewed and so on until the lowest bidder is deemed responsible and selected as the lowest responsible bidder. The Commissioner reserves the right to award the contract to the bidder determined to be the lowest responsible bidder or to reject all bids and rebid the contract in accordance with the General Municipal Law.

#### Section 8. Ongoing Responsibility.

A. The Contractor shall at all times during the Contract term remain responsible. The Contractor agrees, if requested by the Commissioner or his or her designee, to present evidence of its continuing legal authority to do business in New York State, integrity, experience, ability, prior performance, and organizational and financial capacity.

B. Any resident of Erie County who has reason to believe that an awarded contractor is not responsible, may submit to the Commissioner evidence as to why the contractor or subcontractor is not responsible. The Commissioner shall acknowledge receipt of such evidence, and provide a written response within fifteen (15) calendar days.

C. The Commissioner may, upon receipt of such information, conduct a further investigation into whether or not the contractor is responsible and prior to making any determination of non-responsibility shall proceed in accordance with the process set forth in Section 7 above.

#### Section 9. Sanctions.

A. Any contractor or subcontractor, its alter ego or control group, or principal officer who has, after the opportunity to be heard as set forth above, been determined by the Commissioner to be non-responsible, shall be barred from bidding on contracts for the County of Erie for a period of six months for the first violation. In the event the bidder subsequently fails to comply with the provisions of this Local Law on future bids, it may be subject to additional penalties, including prohibition against work on County contracts for three years for the second violation, and permanently for the third violation.

#### Section 10. Emergency.

A. Notwithstanding the provisions of this Local Law, in the case of a public emergency arising out of an accident or any other unforeseen occurrence or condition whereby circumstances affecting public buildings,



public property or the life, health, safety or property of the inhabitants of the County of Erie, which requires immediate action which cannot await competitive bidding or competitive offering, contracts for public work may be let by the appropriate officer, board or agency of the County of Erie without competitive bidding and as it otherwise deems appropriate.

Section 11. Severability.

If any clause, sentence, paragraph, subdivision, section or part of this Local Law or the application thereof, to any person, individual, corporation, firm, partnership, entity or circumstance, shall be adjudged by any court of competent jurisdiction to be invalid or unconstitutional such order of judgment shall not affect, impair, or invalidate the remainder thereof, but shall be confined in its operation to the clause, sentence, paragraph, subdivision, section or part of this Local Law or in its application to the person, individual, corporation, firm; partnership, entity, or circumstance directly involved in the controversy in which such judgment or order shall be rendered.

Section 12. Effective Date.

This Local Law shall take effect 30 days after the filing with the Secretary of State, in accordance with Section 27 of the New York State Municipal Home Rule Law.

Sponsors:

Timothy Meyers  
April N.M. Baskin  
Howard Johnson

**ARTICLE 2 –LOCAL LAW NO. 2 – 2021 FORMS**

Bound following this page are the following which are part of the Contract Documents:

1. New York State (NYS) Vendor Responsibility Form For For-Profit Construction (CCA-2) (SUBMIT WITH BID)
2. NYS Vendor Responsibility Form Attachment A (SUBMIT WITH BID)
3. NYS Vendor Responsibility Form Attachment B (SUBMIT WITH BID)
4. NYS Vendor Responsibility Form Attachment C (SUBMIT WITH BID)



**SECTION 01 11 13**  
**WORK COVERED BY CONTRACT DOCUMENTS**

PART I – GENERAL

1.1 SUMMARY

- A. This section includes a general listing of work items under the Contract. This listing is not meant to be inclusive of all items of work or what is required to accomplish the Work.
- B. The Work is located at various locations in Erie County, New York in Erie County Sewer Districts No. 1, 2, 3, 4, 5, 6, & and 8. Work shall be performed on property owned by the County of Erie or within public highway rights-of-way and/or easements obtained by the County of Erie.
- C. Related Sections:
  - 1. Section 01 14 17 – Coordination with Owner’s Operations
  - 2. Section 01 14 19 – Use of Site
  - 3. Section 01 14 33 – Work in Rights-of-Way
  - 4. Section 01 20 13 – Lump Sum Measurement and Payment
  - 5. Section 01 22 13 – Unit Price Measurement and Payment
  - 6. Section 01 31 13 – Project Coordination (Single Prime)
  - 7. Section 01 41 05 – Regulatory Requirements
  - 8. Section 01 45 05 – Quality Control
  - 9. Section 01 55 33 –Traffic Control
  - 10. Section 01 61 00 – Common Product Requirements
  - 11. Section 01 64 00 – Owner-Furnished Products
  - 12. Section 01 71 34 – Protection of the Work and Property

1.2 INTENT

- A. The Contract Documents are intended to list the components typically used in this term Contract. Work Orders will list what is necessary for the Work on that Work Order, based on the Contract Documents, and are intended to include everything necessary for, the proper and complete orderly execution and finishing of the Work. Any work shown on the Work Order documents which omits express reference to any work which was intended under the Work Order, shall not excuse or relieve Contractor or Subcontractor from furnishing the same. Work or materials described in words which have a well-known technical or trade meaning, shall be interpreted by such customary and recognized standard of meaning.
- B. It is understood that except as otherwise stated in the Contract Documents or Work Order, Contractor shall provide and pay for all permits, materials, labor,

tools, equipment, water, light, power, transportation, superintendence, temporary construction of every nature, and all other services and facilities of every nature necessary to execute, complete and deliver the Work.

- C. Contractor shall ask for clarification where details are not provided for any portion of the Work and for which the design intent cannot be ascertained.

### 1.3 SCOPE OF WORK

#### A. General Requirements

1. Work not identified in the detailed scope of work or bid item description, but nevertheless required, shall be performed as specified, shown or intended.
2. Refer to Sections 01 14 17 Coordination with Owner's Operations, 01 14 19 Use of Site, and 01 14 33 Work in Rights-of-Way for limitations while performing the Work at the site.
3. Refer to Section 01 31 13 Project Coordination (Single Prime) for coordination of the Work.
4. Refer to Sections 01 41 05 Regulatory Requirements, 01 55 33 Traffic Control, 01 61 05 Common Product Requirements, and 01 71 34 Protection of the Work and Property for addition requirements related to the Work.

#### B. The Work includes the following detailed scope:

1. The term construction contract will be in place for a period of two (2) years.
2. Individual Work Orders will be issued in writing for each repair or installation on an as-needed basis. Each Work Order will include a description of the location, scope of work, and estimated cost based on Bid Form unit prices. The Contractor shall begin work within the required timeframe stated in the Work Order letter (typically anticipated to be a duration of five (5) business days of the notice to proceed date stated in the Work Order). Beginning work on the Work Order may include preparation of shop drawings, permit applications, performing a site visit, other submittals, or other documents. The Contractor shall provide the Engineer with a proposed work schedule, traffic control plans, bypass pumping plans, sample homeowner notification letters, and any other submittals or permits as required per the contract, prior to mobilizing to for each Work Order.
3. The work shall primarily consist of performing open cut excavation sewer spot repairs or replacements and associated/appurtenant services for existing 6-inch through 42-inch diameter gravity sewer lines; existing 8-inch through

36-inch forcemain sewers; repair or replacement of sewer manholes; and subsequent restoration activities. The work under this contract shall include all labor, materials, equipment, tools, temporary utilities, health and safety equipment, and all other expenses necessary or as defined in these specifications and/or stated in written work orders to complete work as requested by the Engineer. Work may include, but is not limited to: excavation, disposal, backfill, laying pipe, making pipe connections, connections to manholes, re-establishment of all active lateral connections, backfill, compaction, testing, bypass pumping and all management of existing sewer flows, maintenance and protection of traffic, all necessary restoration and all other related work as indicated in the Contract Documents and Specifications.

4. Supplemental information such as as-built drawings, technical data, CCTV inspection reports, or photos will be provided with the Work Orders, as available. These will be for informational use only and will not be a substitute for the Contractor's proper investigation of existing site conditions.
5. The Contractor will be required to provide written homeowner notifications to impacted property owners at minimum 48 hours in advance of the work / prior to mobilization to the jobsite.
6. A final walkthrough will be completed at each Work Order site following the substantial completion of the Work under the Work Order.

PART 2 PRODUCTS  
NOT USED

PART 3 EXECUTION

3.1 GENERAL

- A. Contractor shall furnish all labor, equipment and materials and shall perform all of the Work as shown in the Contract Documents and as directed by Engineer, tested in place and ready for use, in accordance with the obvious and expressed intent of the Contract to secure a complete installation. In general, the Work to be performed under each pay item is described in the Sections 01 20 13 Lump Sum Measurement and Payment and 01 22 13 Unit Price Measurement and Payment.
- B. The quality of workmanship and materials entering into the Work shall conform to the requirements of Section 01 45 05 Quality Control and the pertinent sections, clauses, paragraphs and sentences provided in the Contract Documents, whether or not direct reference to such occurs in this Summary of Work.

END OF SECTION

**SECTION 01 14 17**  
**COORDINATION WITH OWNER'S OPERATIONS**

PART 1 GENERAL

1.1 SUMMARY

- A. This section includes considerations to be taken when working on Site(s) containing Owner's operations. Owner's operations are critical to maintaining public health. Coordination is essential to minimize impact on those operations.
- B. Related Sections:
  - 1. Section 01 11 13 –Work Covered by Contract Documents
  - 2. Section 01 73 19 - Installation
  - 3. Section 01 73 24 – Connections to Existing Facilities
- C. Refer to Section 01 11 13 Work Covered by Contract Documents for the general listing of the Work to be coordinated.

1.2 GENERAL

- A. Work Orders may be issued on Site(s) containing Owner's operations. The level of coordination required is dependent on the type of operations involved and will be identified in individual Work Orders, as applicable. Types of operations performed by the Owner include the following:
  - 1. Essential operations are operations performed by Owner that must be maintained throughout the entire period of construction or take priority over the Work in the Contract Documents. Limited interruption can be allowed for these operations.
  - 2. Primary operations are operations performed by Owner at this site. Plans for interruptions to these operations are included in the Work Order.
  - 3. Intermittent operations are operations performed by Owner that occur at intervals and that may become essential under certain conditions.
- B. Interruptions to Owner's Operations
  - 1. Interruptions to operations or services must be scheduled and approved in advance. At least three working days of written notice is required prior to work.
  - 2. Owner's representative must be present for all work performed during any interruptions to services.

### 1.3 OPERATIONS

- A. Essential Operations, Primary Operations, and Intermittent Operations will be identified in the Work Order as well as notifications and coordination that must take place at the Site.

### 1.4 SEPARATION

- A. Contractor must provide physical separation between the Work and Owner's existing operations to the greatest extent possible.
- B. Where separation is not possible, Contractor shall provide provisions for Owner's operations to continue as though there was a separation, unless otherwise specified.

### 1.5 OPERATION SCHEDULE

- A. Owner's operations are generally defined as wastewater transmission and treatment and the operations may be continuous or intermittent. The need for equipment and facilities will fluctuate based on the process loading.
- B. Work involving certain operations may be required to occur at specified times. Time restrictions will be identified in individual Work Orders as applicable.
- C. Connections to existing facilities must be coordinated with Owner's current operations to ensure that no interruption of service occurs. Specific requirements and limitations will be detailed in individual Work Orders, as applicable.

### 1.6 NOTIFICATIONS

- A. Contractor must notify Owner's representative, Engineer or Owner for any of the following events:
  - 1. Each time Contractor, or anyone performing work on behalf of Contractor, enters or leaves the Site.
  - 2. Any time that any quantity of wastewater is discharged or spilled outside of its containment system. Examples of a containment system include, without limitation, a pipe, manhole, tank, truck, or channel.
  - 3. Any time operation may be impacted by the Work.
- B. Owner's Representative, Engineer or Owner will notify Contractor:
  - 1. Of any operational changes that will delay the Work. Notice will be given as soon as possible.



2. Of any forthcoming requests for partial use or occupancy.

PART 2 PRODUCTS

NOT USED

PART 3 EXECUTION

NOT USED

END OF SECTION

**SECTION 01 14 19**  
**USE OF SITE**

PART 1 GENERAL

1.1 SUMMARY

- A. This section includes considerations with respect to the Site.
- B. Related Sections:
  - 1. Section 01 11 13 – Work Covered by Contract Documents
  - 2. Section 01 14 17 – Coordination with Owner’s Operations
  - 3. Section 01 14 33 – Work in Rights-Of-Way
- C. Refer to Section 01 11 13 Work Covered by Contract Documents for the general listing of the Work.

1.2 GENERAL

- A. Store apparatus, materials, supplies and equipment in a safe, orderly manner that does not interfere with the Work or normal operations of the surrounding areas. Storage shall not block access in areas of egress.
- B. Refer to Section 01 14 33 Work in Rights-Of-Way for detailed information on work in rights-of-way.
- C. Store materials that are subject to injury by exposure to weather, theft, breakage or otherwise. Limited storage may be available on the Site. Owner will not be responsible for any items stored in their facilities.
- D. Contractor shall follow all rules and requirements specific to the Site, including but not limited to, obeying all signage and following site safety policies.

1.3 EASEMENTS

- A. The required easements obtained for the Project will be indicated on the Plans for individual Work Orders. Contractor shall be responsible for providing any special easement conditions that are contained in the easements as noted in the Work Order. Where, within the limits of the easement, trees are required to be cut, Contractor shall offer the resulting firewood or timber to the property owner on whose land the trees have been felled and provide proof of such offer.
- B. Should there be an easement that Owner is in the process of obtaining; the Contract Documents will indicate as such. No work shall commence in these areas until the easement acquisition has been completed. No change to Contract

Price will be considered for any delay in acquisition of the easement by Owner. Extensions to Contract Time will be considered if requested by Contractor in writing.

#### 1.4 LIMITATIONS

- A. Use of the Site by Contractor is restricted to operations required to complete the Work included in the Contract Documents.
- B. Facilities, buildings, equipment, tools or other that is not property of Contractor shall not be used without written consent.
- C. Contractor shall not dispose of any refuse resulting from the Work, including items demolished at the Site, in refuse containers contained on the Site unless those containers are placed there by Contractor or Contractor has received written authorization for use.
- D. Contractor may be prohibited from entering certain areas of the Site. Some areas may only be prohibited under certain conditions. Refer to Section 01 14 17 Coordination with Owners Operations or individual Work Orders for detailed information.

#### PART 2 PRODUCTS

NOT USED

#### PART 3 EXECUTION

NOT USED

END OF SECTION

**SECTION 01 14 33  
WORK IN RIGHTS-OF-WAY**

PART 1 GENERAL

1.1 SUMMARY

- A. This section includes considerations with respect to working along a roadway in the rights-of-way.
- B. Related Sections:
  - 1. Section 01 11 13 – Work Covered by Contract Documents
  - 2. Section 01 14 17 – Coordination with Owner’s Operations
  - 3. Section 01 14 19 – Use of Site
  - 4. Section 01 41 05 – Regulatory Requirements
- C. Refer to Section 01 11 13 Work Covered by Contract Documents for the general description of items of work along a roadway.

1.2 GENERAL

- A. Work along and under roads, railroads, waterways, airports, or similar locations, shall be completed in accordance with the Contract Documents, and in compliance with permits for the Work issued by the agency of jurisdiction. Permits shall be obtained by Contractor in compliance with General Conditions Article 7.09 and Section 01 41 05 Regulatory Requirements.
- B. The cost of any temporary structures or facilities required by the agency having jurisdiction, shall be paid for by Contractor. The cost of all additional insurance required by the permit shall be provided by Contractor. Contractor shall determine the general requirements of permits of controlling agencies prior to arriving on-site for the Work Order.
- C. Any special backfill required and pavement replacement shall be paid under the appropriate Bid Form items, unless otherwise indicated. All associated materials, equipment, products or other necessary items shall be included in the Contract Price.
- D. The costs of flagging, protective personnel and engineering inspection provided by another agency, including but not limited to those required by a railway, airport, or highway department, shall be at the expense of Contractor.
- E. Refer to Section 01 14 19 Use of Site for information on easements and other requirements.

- F. Owner may need to perform essential operations in the rights-of-way while the Work is being performed. Refer to Section 01 14 17 – Coordination with Owner’s Operations for additional information.

1.3 LIMITATIONS

- A. Contractor equipment shall not be placed or stored in rights-of-way other than where the Work is actively taking place.
- B. All excavations in rights-of-way shall be backfilled in the same work day. When that is not possible, proper safeguards shall be put into place to protect the public.
- C. Environmental permits may be required when dewatering is necessary or when the Work is in close proximity to a water body. Refer to Section 01 41 05 Regulatory Requirements and individual Work Orders for additional information.
- D. Refer to individual Work Orders for additional information.

PART 2 PRODUCTS

NOT USED

PART 3 EXECUTION

NOT USED

END OF SECTION

**SECTION 01 20 13**  
**LUMP SUM MEASUREMENT AND PAYMENT**

PART I – GENERAL

1.1 SUMMARY

- A. This section includes each lump sum item, the scope of work intended to be included in that item, and the way in which work will be measured. The scope of work in this section is intended to provide a general description of work for differentiation.
- B. This section includes how payment will be determined based on the measurement for each lump sum pay item. The scope of work in this section is intended to provide a general description of work for payment differentiation.
- C. The Contract Documents include detailed descriptions of the Work, intended to cooperate and provide for, and include everything necessary for, the proper and complete orderly execution and finishing of the Work.
- D. Related Sections:
  - 1. Section 01 11 13 – Work Covered by Contract Documents
  - 2. Section 01 21 16 – Contingency Allowances
  - 3. Section 01 22 13 – Unit Price Measurement and Payment
  - 4. Section 01 26 10 – Contract Modification Procedures
  - 5. Section 01 29 73 – Schedule of Values
- E. Where separate items identified in this section are not separated on the Bid Form, Contractor shall separate these items on their payment schedule, submitted in accordance with Section 01 29 73 Schedule of Values so measurement can be appropriately identified for payment.
- F. Retention for each Work Order shall be eligible for release when all the Work contained in the Work Order documents is substantially complete, regardless of the completion of any individual Bid Form item.
- G. Final payment for each Bid Form item shall be for the remainder of the lump sum price stated in the proposal unless modifications have been made to the Contract or set-offs have been imposed. Refer to Section 01 26 00 Contract Modification Procedures and GCC Article 14 for information on what modifications may impact final payment.

1.2 BID FORM ITEM NO. 33: LUMP SUM CONTINGENCY ALLOWANCE

- A. Scope of Work

1. Contractor shall furnish all labor, materials, equipment, products and other items required to perform unspecified additional work as determined in the field and authorized in writing by Engineer. Work performed under this item is to be determined based on approved Contractor proposals. See Section 01 21 16 Contingency Allowances for detailed information.

B. Measurement

1. Measurement shall be the actual work performed under this item, recommended for payment by Engineer and approved by Owner.
2. Measurement for approved unit price work under this item shall be the number of units completed, as determined by Engineer.
3. Measurement for approved lump sum work under this item is the percentage of the total work completed, as determined by Engineer.

PART 2 PRODUCTS

NOT USED

PART 3 EXECUTION

NOT USED

END OF SECTION



**SECTION 01 21 16  
CONTINGENCY ALLOWANCES**

PART 1 GENERAL

1.1 SUMMARY

- A. This section includes considerations related to contingent items of work added after the Contract is executed and payment of contingent items.
- B. Related Sections:
  - 1. Section 01 20 13 – Lump Sum Measurement and Payment
  - 2. Section 01 22 13 – Unit Price Measurement and Payment
  - 3. Section 01 33 10 – Submittal Procedures

1.2 GENERAL

- A. Refer to Sections 01 20 13 Lump Sum Measurement and Payment and Section 01 22 13 Unit Price Measurement and Payment for the procedures for measurement of the Work and payment limits.
- B. Contractor is not entitled to the sums included under contingency allowance items unless work is approved for these items. Work will not be added to the Contract for the sole purpose of allowing full payment to Contractor of the amounts included in these allowances.
- C. Any work performed under a contingency allowance item must receive written acceptance and approval before proceeding. Any work performed without written approval will be at Contractor's risk.
- D. Engineer may recommend and Owner may allow payment before the final change order. Otherwise additional work will be accounted for in the final change order as stipulated in GC Article 13.02-D.
- E. All work performed under contingency allowances shall be included on the red-lined drawings upon completion of the Work.

1.3 SUBMITTALS

- A. Contractor shall submit, for approval, all items required to perform the proposed work, regardless if the item(s) was listed in original Bid Form. Refer to Section 01 33 10 Submittal Procedures for detailed information on submittals.
- B. If work includes an item already submitted and approved, the proposal shall indicate the item and identify the approved submittal.

- C. Contractor shall submit supporting documentation for any estimates related to allowances. This documentation includes, without limitation, estimates from Sub-Contractors, hour and cost worksheets, labor or equipment cost estimate sources, material cost sources, diagrams, or field measurements.

#### 1.4 LUMP SUM ALLOWANCES

- A. Engineer will request a proposal for work to be completed under the Contingency Allowance.
- B. Any proposal received from Contractor must include pricing that is in accordance with unit prices or estimates already provided. Pricing must be industry standard for the location, and must be supported in submittals.
- C. Contingent items of work can only be performed after Engineer's written recommendation and Owner's written acceptance of the proposal. Owner must approve payment amount in writing.
- D. The project schedule will be updated to reflect any work added under the Contingency Allowance, upon acceptance of work.
- E. Contingency Allowance will be paid in accordance with Section 01 20 13 Lump Sum Measurement and Payment.

#### 1.5 UNIT PRICE ALLOWANCES

- A. Unit price allowances include all costs necessary to accomplish the Work in accordance with the Contract Documents. This includes, but is not limited to, materials, labor, equipment, overhead, profit, supervision, shipping, freight, storage, permitting requirements, and any other incidental costs.
- B. Engineer will determine the extent of work to be completed under the Unit Price Allowances. Engineer or Owner must approve work.
- C. Unit Price allowances will be paid in accordance with Section 01 22 13 Unit Price Measurement and Payment.

### PART 2 PRODUCTS

NOT USED

### PART 3 EXECUTION

NOT USED

END OF SECTION

**SECTION 01 22 13  
UNIT PRICE MEASUREMENT AND PAYMENT**

PART I – GENERAL

1.1 SUMMARY

- A. This section includes each unit priced Bid Form item, the scope of work intended to be included in that item, and the way in which work will be measured. The scope of work in this section is intended to provide a general description of work for Bid Form item differentiation.
- B. Individual Work Orders issued to the Contractor shall include detailed descriptions of the Work. Applicable Bid Form items intended to be used will be identified and shall provide for, and include everything necessary for, the proper and complete orderly execution and finishing of the Work.
- C. Related Sections:
  - 1. Section 01 11 13 – Work Covered by Contract Documents
  - 2. Section 01 21 16 – Contingency Allowances
  - 3. Section 01 26 10 – Contract Modification Procedures
  - 4. Section 01 29 76 – Progress Payment Procedures
- D. Section 01 11 13 Work Covered by Contract Documents contains a general listing of all the Work included in the Contract Documents.
- E. Quantities provided in the Bid Form section were for the sole purpose of determining a low bidder. Actual quantities will be assigned on a Work Order basis throughout the term.
- F. The work shall be performed in accordance with the Work Orders and Details, as specified, or as directed by the Engineer and shall comply with the permit requirements of the Departments or agencies, public or private, having jurisdiction. The Contractor shall obtain and pay for all necessary permits required in order to perform the work.
- G. The Unit Price Bid Form Items are divided into the following categories:
  - 1. Part 1 - Contractor Bid Price Items – Bid Form Items No. 1-6
  - 2. Part 2 - Minimum Bid Price Items – Bid Form Items No. 7-28, &
  - 3. Part 3 - Fixed Bid Price Items - Bid Form Items No. 29-31

## CONTRACTOR BID PRICE ITEMS

### 1.2 BID FORM ITEM NO. 1 - INSTALL/REPLACE GRAVITY SEWER (ANY DIAMETER)

#### A. Scope of Work

1. This Bid Form item includes all labor, materials, equipment, processes, products and other items required to perform sanitary or storm sewer pipe open cut excavation spot repairs at the locations noted in authorized written Work Orders, and for the diameters, lengths of repair, and depths indicated per the sub-items No. 1A through 1X, as itemized on the Bid Form.
2. The Work under this Item includes, but is not limited to, the following:
  - a. Homeowner notifications.
  - b. Protection of existing utilities. Locating existing buried electric, gas, telephone, water, sewer, laterals, and other utilities in advance of pipe laying, and establishing their exact location and grade; protecting and supporting utilities less than 4-inches in diameter and all house service lines (water, sewer, gas, electric, telephone and drain);
  - c. Maintenance of existing flows; bulkheading and plugging of sewers; bypass piping; bypass pumping systems; complete handling of all materials, wet or dry.
  - d. Handling of water in trenches, including pumping and bailing, well points, or deep well pumping.
  - e. Saw cutting; excavation of materials, including rock, masonry, stone, boulders, etc. to the depth required; proper disposal of excavated material; etc.
  - f. Temporary sheeting/shoring; use of trench shield.
  - g. Removal and proper disposal of existing piping.
  - h. Furnishing and installing new polyvinyl chloride (PVC) sewer piping at all depths, laying pipe and making joints.
  - i. Pipe bedding, backfilling with excavated soils and

compaction.

- j. Pipe testing in accordance with Division 2.
  - k. Basic maintenance and protection of traffic including signage, cones, flashers, traffic drums/barrels, and watchmen, if required.
  - l. All other work items included in the Work Order Documents necessary to complete the Work as a whole and which is not specifically included under the other Items of the Contract shall be included under this Item.
3. In areas where select backfill is required, the unit price cost of the select backfill shall be paid under Bid Form Item No. 11 and in accordance with trench paywidth shown on the Standard Details.
  4. All live sewer laterals within the spot repair location shall be re-instated/re-connected by the Contractor. The unit price cost for these connections including wye branch and flexible repair couplings shall be paid under Bid Form Items No. 4. Length of new lateral pipe and riser pipe as needed shall be paid under Bid Form Item No. 3.
  5. It shall be the Contractor's responsibility to locate and verify all live service connections that require re-instatement/re-connection. In the event that active service connections are missed or are not properly reconnected, it will be the Contractor's responsibility to reconnect said service at no additional cost to the Owner. If the Contractor fails to reconnect any live service connections, the cost of damages resulting from this failure shall be borne entirely by the Contractor.
  6. This Bid Form Item does not include select backfill, pavement, driveway, sidewalk, or lawn restoration included in other Bid Form Items.
  7. In areas of poor soil conditions, as determined by the Engineer, the Contractor will be required to provide additional stone base undercut material in addition to the specified pipe bedding material. Costs for this additional stone base material and undercutting of the trench shall be included in Bid Form Item No. 12.
  8. The work under this item does not include material and work is to be included in the unit prices for sewer to sewer connections (i.e., flexible repair couplings, etc.) under Bid Form Item No. 4.

B. Measurement and Payment

1. Measurement of work completed under this Bid Form item shall be the measured length made in a horizontal plane along the centerline of the pipe for the length of spot repair completed and approved for payment by the Engineer. The length shall include the length of wye fittings. Deductions shall be made for poured-in-place or precast manholes and structures. Measurement of depth shall be made from the original ground surface to the invert of the pipe. **The minimum length of repair paid shall be twelve (12) linear feet.**
2. Payment under this Bid Form item shall be the linear footage of pipe installed, as measured by the Engineer, less any deductions.
3. If Engineer determines any work to be defective, deductions may be taken from the payment in accordance with GC Article 14.03-F.

1.3 BID FORM ITEM NO. 2 – INSTALL/REPLACE FORCEMAIN SEWER (ANY DEPTH)

A. Scope of Work

1. This Bid Form item includes all labor, materials, equipment, processes, products and other items required to perform open cut excavation spot installations or repairs on ductile iron forcemain sewers of any depth (estimated 4 to 8 feet deep to invert) at the locations noted in authorized written Work Orders and for the diameters and lengths of repair, indicated per the sub-items No. 2A through 2I as itemized on the Bid Form.
2. The Work under this Item includes, but is not limited to, the following:
  - a. Homeowner notifications.
  - b. Protection of existing utilities. Locating existing buried electric, gas, telephone, water, sewer, laterals, and other utilities in advance of pipe laying, and establishing their exact location and grade;
  - c. Maintenance of existing flows; bulkheading and plugging of sewers; bypass piping; bypass pumping systems; complete handling of all materials, wet or dry.
  - d. Handling of water in trenches, including pumping and bailing, well points, or deep well pumping.

- e. Saw cutting; excavation of materials, including rock, masonry, stone, boulders, etc. to the depth required; proper disposal of excavated material; etc.
  - f. Temporary sheeting/shoring; use of trench shield.
  - g. Removal and proper disposal of existing piping.
  - h. Furnishing and installing new ductile iron piping at all depths, laying pipe and making joints.
  - i. Pipe bedding, backfilling with excavated soils and compaction.
  - j. Basic maintenance and protection of traffic including signage, cones, traffic drums/barrels, flashers, and watchmen, if required.
  - k. All other work items included in the Contract Documents necessary to complete the project as a whole and which is not specifically included under the other Items of the Contract shall be included under this Item.
3. In areas where select backfill is required, the unit price cost of the select backfill shall be paid under Bid Form Item No. 11 and in accordance with trench paywidth shown on the Standard Details.
4. This Bid Form Item does not include select backfill, pavement, driveway, sidewalk, or lawn restoration included in other Bid Form Items.
5. In areas of poor soil conditions, as determined by the Engineer, the Contractor will be required to provide additional stone base undercut material in addition to the specified pipe bedding material. Costs for this additional stone base material and undercutting of the trench shall be included in Bid Form Item No. 12.
6. The work under this item does not include material and work is to be included in the unit prices for sewer to sewer connections (i.e., mechanical joints, etc.) under Bid Form Item 4.

B. Measurement and Payment

- 1. Measurement of work completed under this Bid Form item shall be the measured length made in a horizontal plane along the centerline of the pipe

for the length of spot repair completed and approved for payment by the Engineer. The length shall include the length of fittings. Deductions shall be made for poured-in-place or precast manholes and structures. Measurement of depth shall be made from the original ground surface to the invert of the pipe. **The minimum length of spot repair paid shall be twelve (12) linear feet.**

2. Payment under this Bid Form item shall be the linear footage of pipe installed, as measured by the Engineer, less any deductions.
3. If Engineer determines any work to be defective, deductions may be taken from the payment in accordance with GC Article 14.03-F.

#### 1.4 BID FORM ITEM NO. 3 – INSTALL/REPLACE SEWER LATERALS

##### A. Scope of Work

1. This Bid Form item includes all labor, materials, equipment, processes, products and other items required to furnish and install or replace sanitary sewer lateral pipe at the locations noted in authorized written Work Orders or as required to reinstate existing laterals in spot repair areas, and per the diameters and depths indicated per the sub-items No. 3A and 3B. as itemized on the Bid Form.
2. This Bid Form item includes all labor, materials, equipment, processes, products and other items required to furnish and install or replace sewer cleanouts and valve boxes at the locations noted in authorized written Work Orders or as required to reinstate existing laterals in spot repair areas, and per the applicable sub-items No. 3C through 3F. as itemized on the Bid Form.
3. The Bid Form item includes but is not limited to: installation or replacement of sewer laterals and cleanouts at any depth including basic maintenance and protection of traffic including signage, cones, traffic drums/barrels, flashers, and watchmen, if required; excavation of all materials and existing pipe; removal and disposal of excavated material and existing pipe; shoring and bracing; handling of water and sewage flows, maintenance of existing flows; disposal of surplus material excavated from the trench; furnishing and laying pipe and making joints; use of trench shield; backfilling of pipe trenches and bedding of pipe in earth and rock trenches according to the typical details; filling as required; filling authorized excavation with soil or excavated material; bedding; riser pipes as applicable; cleanouts, fittings, elbows, appurtenances, and all other work required for a complete installation. Lateral pipe shall be replaced to the extents identified in the Work Order or in writing by the Engineer.
4. In areas where select backfill is required, the unit price cost of the select



backfill shall be paid under Bid Form Item No. 11 and in accordance with trench paywidth shown on the Standard Details.

5. This Bid Form Item does not include restoration, unless specifically identified above. All pavement replacement shall be performed in accordance with the requirements of the State, County and/or Town Highway Departments or other agency having jurisdiction over the highway and shall be paid under Bid Form Item Nos. 6 and 7. All lawn restoration including topsoil and seeding shall be paid under Bid Form Item No. 20.
6. In areas of poor soil conditions, as determined by the Engineer, the Contractor will be required to provide additional stone base undercut material in addition to the specified pipe bedding material. Costs for this additional stone base material and undercutting of the trench shall be included in Bid Form Item No. 12.
7. The work under this item does not include material and work that is included in the unit prices for lateral connections under Bid Form Item 7 (i.e., wye branches).

#### B. Measurement and Payment

1. For Bid Form Items No. 3A and 3B: Measurement of work completed under this Bid Form item shall be the measured linear footage of sanitary lateral pipe installed as measured from outside the trench excavation for the main sewer to the connection point to the existing lateral. Payment under this Bid Form item shall be the linear footage of pipe installed, as measured by the Engineer, less any deductions.
2. For Bid Form Items No. 3C, 3D, 3E, and 3F: Measurement of work completed under this Bid Form item shall be the number (per each) of cleanouts or valve box covers installed. Payment under this Bid Form item shall be the number of cleanouts or valve box covers installed, as measured by the Engineer.
3. If Engineer determines any work to be defective, deductions may be taken from the payment in accordance with GC Article 14.03-F.

### 1.5 BID FORM ITEM NO. 4 – SEWER CONNECTIONS

#### A. Scope of Work

1. This Bid Form item includes all labor, materials, equipment, processes, products and other items required to make various sewer connections, of various diameters and at various depths, under the applicable sub-items 4A

through 4I as itemized on the Bid Form including:

- a. Bid Form Item No. 4A: Connecting existing laterals to sewer spot repairs via wye fittings,
- b. Bid Form Item No. 4B: Connecting new lateral pipe to existing laterals via flexible repair couplings, or connecting new sewers to existing sewers via flexible repair couplings,
- c. Bid Form Item No. 4C: Making connections from forcemain spot repairs to the existing pipe,
- d. Bid Form Item No. 4D: Making connections of new or replacement sewers to manholes. Work shall include making a new sewer connection to either: 1) an existing manhole with an existing cutout and/or pipe opening; 2) an existing manhole with a newly cored pipe opening (as completed under Bid Form Item Nos. 4E, 4F, 4G), or 3) a new manhole with a new watertight boots, cutouts or cored pipe openings, less one (1) connection included in Bid Form Item Nos. 5A through 5E). The work shall include all work to make a proper sewer pipe connection to the manhole, mortar grouting, invert/bench work and/or repairs as necessary, and coatings.
- e. Bid Form Item Nos. 4E through 4G: Coring existing sanitary or storm manholes, for the diameters indicated. Work shall include coring a pipe opening in an existing brick or precast manhole in order to facilitate a new sewer connection, or for field cores of a new precast manhole where approved by the Engineer. Work shall include coring a pipe opening of a suitable diameter to facilitate installation of the sewer pipe scheduled for connection. This item shall not include work to make the sewer connection as included and paid under Bid Form Item No. 4D.
- f. Bid Form Item No. 4H: Connecting storm sewer to catch basins. Work shall include installing a storm sewer connection (6-inch to into an existing or new catch basin (into an existing cutout or pipe opening) including storm lateral pipe connection, mortar

grouting, and coatings.

- g. Bid Form item No. 4I: Connecting laterals to sewers via flexible tap saddle (or approved equal). Work shall include furnishing and installing the service connection fitting, the length of the lateral pipe inside the trench excavation of the main sewer, and connection of the lateral pipe to the existing lateral pipe, with flexible repair couplings, if required. The unit price Bid Form shall include all flexible tap saddles, elbows, couplers, rubber sleeves, stainless steel bands, screws, housing, gaskets, hydraulic cement, etc. as required.
2. The work shall include location and protection of existing utilities, excavation of all materials, disposal of excavated material, bedding stone, sheeting and shoring, backfill excavated materials, hydraulic cement, pipe, fittings, flexible repair couplings, couplers, or other appurtenances required for the sewer connection as shown in the Work Orders, Details, as specified, or as directed by the Engineer. The Contractor shall furnish service connection fittings compatible with the pipe type and diameter and install in accordance with all manufacturer's recommendations.
3. The Contractor shall assist the RPR in collecting record drawing information for the location of lateral connections within the spot repair. The Contractor shall assist the RPR in determining the location of lateral connections via wye branch as measured from the last downstream manhole as well as at least two ties to existing structures, preferably the corners of the house for which the wye branch is intended.

B. Measurement and Payment:

1. Bid Form Item No. 4A – Connecting Lateral to Sewer (Wye Fitting): Measurement of work completed under this Bid Form item shall be the measured number of wye fittings installed (per Each), and shall include the length of the lateral pipe inside the trench excavation of the main sewer including riser pipers and all fittings, elbows, couplers, etc., and connection of the lateral pipe to the existing lateral pipe with flexible repair coupling or reducer, as required. Payment under this Bid Form item shall be the number of lateral to sewer (wye fitting) connections installed, as measured by the Engineer.
2. Bid Form Item No. 4B – Connecting Sewer to Sewer (Flexible Repair Couplings): Measurement of work completed under this Bid Form item shall be the measured number of flexible repair coupling connections (mainline

sewer to mainline sewer) (per Each) installed. Work for connecting new sewer to manholes is not included in this item. Work to make stormline pipe connections to repair utility crossings in the excavation is not included in this item. Payment under this Bid Form item shall be the number of sewer to sewer (flexible repair coupling) connections installed, as measured by the Engineer.

3. Bid Form Item No. 4C – Forcemain Sewer Connections: Measurement of work completed under this Bid Form item shall be the measured number of mechanical joint couplings or fittings installed and connected (per Each). Material costs are not included in this Bid Form item and shall either be 1) provided by Owner for installation by Contractor or 2) furnished by Contractor and compensated at invoiced costs plus allowable overhead and profit markups per the General Conditions. Payment under this Bid Form item shall be the number of forcemain sewer to forcemain sewer (mechanical joint coupling) connections installed, as measured by the Engineer.
4. Bid Form Item No. 4D – Connecting Sewer to Manhole: Measurement of work completed under this Bid Form item shall be the measured number of watertight sewer connections (per Each). Payment under this Bid Form item shall be the number of sewer to manhole connections installed, as measured by the Engineer.
5. Bid Form Item No. 4E – Manhole Coring (8” – 12”) Sewer; Bid Form Item No. 4F – Manhole Coring (>12” – 24”) Sewer; Bid Form Item No. 4G – Manhole Coring (>24” – 42”) Sewer: Measurement of work completed under this Bid Form item shall be the measured number of manhole cores (per Each) to facilitate a pipe connection in a new or existing manhole. Payment under this Bid Form item shall be the number of manhole cores installed, as measured by the Engineer.
6. Bid Form Item No. 4H – Connecting Storm Sewer to Catch Basin: Measurement of work completed under this Bid Form item shall be the measured number of storm sewer to catch basin connections (per Each) performed. Payment under this Bid Form item shall be the number of storm sewer to catch basin connections installed, as measured by the Engineer.
7. Bid Form Item No. 4I – Connecting Lateral to Sewer (Tap Saddle Fitting): Measurement of work completed under this Bid Form item shall be the measured number of tap saddle) installed (per Each), and shall include the length of the lateral pipe inside the trench excavation of the main sewer including riser pipes and all fittings, elbows, couplers, etc., and connection of the lateral pipe to the existing lateral pipe with flexible repair coupling or reducer, as required. Payment under these Bid Form items shall be the number of lateral to sewer (tap saddle) connections installed, as measured by the Engineer

8. If Engineer determines any work to be defective, deductions may be taken from the payment in accordance with GC Article 14.03-F.

## 1.6 BID FORM ITEM NO. 5 – INSTALL/REPLACE MANHOLE/CATCH BASIN

### A. Scope of Work

1. This Bid Form item includes all labor, materials, equipment, processes, products and other items required to furnish and install standard and doghouse precast concrete manholes and precast concrete catch basins, under the applicable sub-items 5A through 5I as itemized on the Bid Form.
2. Standard Manholes – The work shall include furnishing all labor, materials, tools, equipment and incidentals required to furnish and place standard manholes with precast concrete base sections of the diameters required, including all excavation, including rock, to the required depths; removal and disposal of existing manhole as required; concrete bases of the required diameter; reinforced concrete barrel sections (without lifting holes); reducer section, neoprene gasket and joint compound; install riser rings and cast iron frames and covers (furnished by Owner); stubs with plugs where indicated and/or as ordered by the Engineer; reinforced polypropylene manhole steps; reinforced concrete slab top for manholes less than 5'-0" in depth; pumping and/or bailing as required; concrete construction; concrete bench; perforated plastic pipe for testing, where directed; bedding; backfill with excavated materials or soil; mortar; coatings; furnish and install one (1) 4'-0" minimum pipe stub and all work to connect one (1) pipe stub to the manhole; and other incidentals; testing of completed work; basic maintenance and protection of traffic including signage, cones, traffic drums/barrels, flashers, and watchmen, if required; and all other work or expense required for a complete installation and not included in other Bid Form Items. All manholes shall conform in all respects to Section 02376 of these Specifications. Where manholes require more than one pipe connection, the subsequent pipe connection work shall be paid under Bid Form Items No. 4C and the applicable pipe Bid Form Items No. 1A through 1X. This item does not include pipe to pipe connections made with flexible repair couplings paid for under Bid Form Item No. 4B.
3. Doghouse Manholes - The work shall include furnishing all labor, materials, tools, equipment and incidentals required to furnish and place "doghouse"-style manholes with base sections of the diameters required and poured concrete footer pads, including all excavation, including rock, to the required depths; concrete bases of the required diameter; all excavation, formwork, reinforcing, concrete work required to install the footer pad; protection of the existing sanitary sewer during installation of the doghouse manhole structure;

reinforced concrete barrel sections (without lifting holes); reducer section, neoprene gasket and joint compound; install riser rings and cast iron frames and covers (furnished by Owner); stubs with plugs where indicated and/or as ordered by the Engineer; reinforced polypropylene manhole steps; reinforced concrete slab top for manholes less than 5'-0" in depth; pumping and/or bailing as required; concrete construction; concrete bench; perforated plastic pipe for testing, where directed; bedding; backfill with excavated materials or soil; mortar; coatings; furnish and install pipe stubs and other incidentals; testing of completed work; basic maintenance and protection of traffic including signage, cones, traffic drums/barrels, flashers, and watchmen, if required; and all other work or expense required for a complete installation and not included in other Bid Form Items. All manholes shall conform in all respects to Section 02376 of these Specifications

4. Precast Concrete Catch Basin - The work shall include furnishing all labor, materials, tools and equipment required to furnish and install precast concrete catch basins including basic maintenance and protection of traffic including signage, cones, flashers, traffic drums/barrels, and watchmen, if required; excavation of all materials; shoring and bracing; disposal of excavated material; bedding; backfill; brick; mortar; coatings; two (2) foot section of lateral pipe extending from the exterior face of the catch basin connection to laterals and underdrains; catch basin structure; risers; frames and grates; as shown in the Work Orders, Details, and specified, or as directed by the Engineer.
5. The manhole frames and covers and concrete riser rings (various sizes) shall be provided by the Owner. The frames and covers will be located at the respective Sewer District offices in which the repair is taking place, and it will be the Contractor's responsibility to pick them up at these locations.

#### B. Measurement and Payment

1. Bid Form Items No. 5A through 5H: Measurement of work completed under this Bid Form item shall be the measured vertical linear footage (VLF) of manholes installed, tested, and approved by the Engineer, measured from the top of the cover to the lowest pipe invert of the manhole. **The minimum manhole depth paid shall be four (4) VLF.** Payment under this Bid Form item shall be the number of vertical linear footage installed, as measured by the Engineer.
2. Bid Form Items No. 5I: Measurement of work completed under this Bid Form item shall be the measured: Measurement of work completed under this Bid Form item shall be the measured vertical linear footage (VLF) of catch basins

installed, tested, and approved by the Engineer, measured from the top of the cover to the lowest invert of the catch basin. **The minimum catch basin depth paid shall be four (4) VLF.** Payment under this Bid Form item shall be the number of vertical linear feet installed, as measured by the Engineer.

3. If Engineer determines any work to be defective, deductions may be taken from the payment in accordance with GC Article 14.03-F.

#### 1.7 BID FORM ITEM NO. 6 – PAVEMENT REPLACEMENT/RESTORATION

##### A. Scope of Work

1. This Bid Form item includes all labor, materials, equipment, processes, products and other items required to remove and replace existing asphalt pavement and concrete road base, for the various depths and areas indicated, under the applicable sub-items 6A through 6P as itemized on the Bid Form.
2. The Bid Form Items are intended to remove and replace existing pavement disturbed by the sewer pipe or manhole trenches.
3. All permits required by State, County and/or Town Highway Department to perform the work, will be obtained and paid for by the Contractor prior to construction. If there is any variance between the provisions of the permits and the Specifications, the provisions of the permit shall supersede those of the Specifications.
4. The work shall include removal of existing pavement, replacement with an asphalt or concrete base, hot mix asphalt binder, tack coat and top course where indicated in the Work Orders and Details, determined in the field or as ordered by the Engineer, within the pay widths indicated in the Details and in conformance with the requirements of the State, County, and/or Town Highway Departments or other agency having jurisdiction over the highway. For concrete road base installation, the work shall include concrete dowelling to existing concrete base as applicable and reinforcing.
5. The work for this item shall include all labor and materials for trench restoration including furnishing and installing base, binder, seal coat, tack coat, top course, obtaining and complying with highway permits.
6. Where directed by the Engineer, the furnishing and placing of cold patch pavement shall be paid under Bid Form Items No. 7D and 7E. The Contractor shall maintain the cold patch pavement for the duration required. No additional payment shall be made to maintain or reinstall cold patch.

B. Measurement and Payment:

1. Measurement of work completed under this Bid Form item shall be the measured square footage installed within the specified pay limits, measured as the sewer trench pay limit width multiplied by the number of linear feet of sewer spot repair installed, as measured along the centerline of the improvements.
2. Payment under this Bid Form item shall be the square footage installed within the specified pay limits, as measured by the Engineer.
3. If Engineer determines any work to be defective, deductions may be taken from the payment in accordance with GC Article 14.03-F.

MINIMUM BID PRICE ITEMS

1.8 BID FORM ITEM NO. 7 – MISCELLANEOUS PAVEMENT RESTORATION

A. Scope of Work

1. This Bid Form item includes all labor, materials, equipment, processes, products and other items required to perform miscellaneous pavement restoration including heavy duty pavement, medium duty pavement, light duty pavement, and concrete roadbase restoration, for the areas designated under the applicable sub-items 7A through 7J as itemized on the Bid Form.
2. Work under this Bid Form item includes milling; installation of tack coat and top course; installation and maintenance of temporary pavement patch (cold patch) where required or as directed by the Engineer; shoulder replacement; additional sawcuts; and pavement striping/letters/symbols.
3. Work may be where indicated on in the Work Orders and Details, determined in the field or as ordered by the Engineer, within the pay widths indicated in the Details and in conformance with the requirements of the State, County, and/or Town Highway Departments or other agency having jurisdiction over the highway. Refer to Bid Form Item No. 6 for additional applicable pavement restoration notes.
4. The furnishing and placing of cold patch pavement if directed by the Engineer shall be paid under Bid Form Items No. 7D and 7E. The Contractor shall maintain the cold patch pavement for the duration required. No additional payment shall be made to maintain or reinstall cold patch. The minimum depth of pavement patch shall be 4 inches.



5. Bid Form Item No. 7G: Additional Sawcut (Pavement) - Where approved as extra work, the Contractor shall furnish all labor, materials, tools and equipment required to perform additional pavement sawcutting as shown in accordance with Section 02600. The work under this item does not include work that is to be included in the unit prices for pavement restoration under Bid Form Item No. 6 (i.e, does not include the requirement to cut back pavement one foot onto undisturbed earth on each side of the excavation).
6. Bid Form Item Nos. 7H through 7J: Pavement Stripe, Pavement Letter, and Pavement Symbol: The Contractor shall furnish all labor, materials and equipment necessary to restore pavement marking paint to match existing conditions, or as ordered by the Engineer.

B. Measurement and Payment:

1. Miscellaneous Cold Milling of Asphalt Concrete (Bid Form Item Nos. 7A & 7B): Measurement of work completed under this Bid Form item shall be the actual number of square feet milled, within the specified pay limits as detailed in the Work Orders and Details, or where directed by the Engineer. Payment under this Bid Form item shall be the square footage performed within the specified pay limits, as measured by the Engineer.
2. 1-1/2" Top Course Asphalt Concrete Pavement Restoration in areas of cold milling only (Bid Form Item No. 7C): Measurement of work completed under this Bid Form item shall be the actual number of square feet installed, within the specified pay limits as detailed in the Work Orders and Details, or where directed by the Engineer. Payment under this Bid Form item shall be the square footage installed within the specified pay limits, as measured by the Engineer.
3. Temporary Pavement Patch (Asphalt, Concrete) (Bid Form Items No. 7D and 7E) – Measurement of work completed under this Bid Form item shall be the actual number of square feet installed, which shall be measured as the sewer trench pay limit width multiplied by the number of linear feet of sewer spot repair installed, or as detailed in the Work Orders and Details, or where directed by the Engineer. Payment under this Bid Form item shall be the square footage installed within the specified pay limits, as measured by the Engineer.
4. Road Shoulder Removal and Replacement (Bid Form Item No. 7F) – Measurement of work completed under this Bid Form item shall be the actual square feet of road shoulder installed, within the specified pay limits as

detailed in the Work Orders and Details, or where directed by the Engineer. Payment under this Bid Form item shall be the square footage installed within the specified pay limits, as measured by the Engineer.

5. Additional Sawcut (Pavement) (Bid Form Item No. 7G) – Measurement of work completed under this Bid Form item shall be the actual linear feet of sawcut, as measured along the centerline of the sawcut, within the specified pay limits as detailed in the Work Orders and Details, or where directed by the Engineer. Payment under this Bid Form item shall be the linear footage installed within the specified pay limits, as measured by the Engineer.
6. Pavement Stripe (Bid Form Item No. 7H) – Measurement of work completed under this Bid Form item shall be the actual number of lineal feet of painted pavement stripe, as measured along the centerline of stripe, within the specified pay limits as detailed in the Work Orders and Details, or where directed by the Engineer. Payment under this Bid Form item shall be the linear footage installed within the specified pay limits, as measured by the Engineer.
7. Pavement Letter (Bid Form Item No. 7I) and Pavement Symbol (Bid Form Item No. 7J)– Measurement of work completed under this Bid Form item shall be the actual number of painted letters or symbols, respectively, where detailed in the Work Orders, or where directed by the Engineer. Payment under this Bid Form item shall be the number of letters or symbols, as measured by the Engineer.
8. If Engineer determines any work to be defective, deductions may be taken from the payment in accordance with GC Article 14.03-F.

#### 1.9 BID FORM ITEM NO. 8 – DROP MANHOLE PIPE ASSEMBLIES

##### A. Scope of Work

1. This Bid Form item includes all labor, materials, equipment, processes, products and other items required to install an inside drop pipe assembly into a manhole for the various diameters under the applicable sub-items 8A through 8D as itemized on the Bid Form.
2. The work shall include the complete drop pipe assembly including drop pipe or bowl, fittings, couplings, anchorage, invert/bench work and/or repairs as required, and all other work or expense required for a complete installation and not included in other Bid Form Items.

##### B. Measurement and Payment:

1. Measurement of work completed under this Bid Form item shall be the measured actual number of drop pipe assemblies installed.

2. Payment under this Bid Form item shall be the actual number of drop pipe assemblies installed as measured by the Engineer.
3. If Engineer determines any work to be defective, deductions may be taken from the payment in accordance with GC Article 14.03-F.

#### 1.10 BID FORM ITEM NO 9 – CONCRETE CRADLE AND ENCASEMENT

##### A. Scope of Work

1. This Bid Form item includes all labor, materials, equipment, processes, products and other items required to furnish and place concrete for sewer cradle and encasement.
2. The Contractor shall furnish all labor, materials, tools and equipment required to furnish and place Class 2000 psi concrete for encasement of sewers where indicated in the Work Orders, Details, as specified, or where ordered by the Engineer.
3. Concrete encasement shall be required for the following conditions:
  - a. Where required by the conditions of a governing permit,
  - b. Where there is less than 18 inches of vertical clearance and/or less than 10 feet horizontal clearance between an existing water main and the proposed sewer. For crossings, the concrete encasement shall extend for 3 feet to each side of the water main centerline.
  - c. Where a proposed sewer crosses under any roadway, and the distance from the top of roadway to top of sewer is less than 4 feet. For roadway crossings the concrete encasement shall extend for 2 feet beyond the edge of payment.

##### B. Measurement and Payment:

1. Measurement of work completed under this Bid Form item shall be the measured cubic yards of concrete cradle and encasement installed within the specified pay limits.
2. Payment under this Bid Form item shall be the measured cubic yards of concrete cradle and encasement installed within the specified pay limits, as measured by the Engineer.

3. If Engineer determines any work to be defective, deductions may be taken from the payment in accordance with GC Article 14.03-F.

#### 1.11 BID FORM ITEM NO. 10 – ADDITIONAL CRUSHED STONE BEDDING

##### A. Scope of Work

1. This Bid Form item includes all labor, materials, equipment, processes, products and other items required to place and consolidate crushed stone bedding as shown on plans and in accordance with Section 02200, where approved as extra work.
2. The work shall include the hauling and disposal of surplus excavated material being replaced by the crushed stone bedding.
3. The work under this item does not include material and work that is to be included in the unit prices for sewer pipe or structures under Bid Form Items No. 1 through 5.

##### B. Measurement and Payment:

1. Measurement of work completed under this Bid Form item shall be the measured actual cubic yards of crushed stone bedding installed as directed in writing by the Engineer, prior to the work being done.
2. Payment under this Bid Form item shall be the actual cubic yards of crushed stone bedding installed within the specified pay limits, as measured by the Engineer.
3. If Engineer determines any work to be defective, deductions may be taken from the payment in accordance with GC Article 14.03-F.

#### 1.12 BID FORM ITEM NO. 11 – SELECT MATERIAL BACKFILL

##### A. Scope of Work

1. This Bid Form item includes all labor, materials, equipment, processes, products and other items required to install select material backfill for backfilling trench, manhole or structure excavations as in accordance with Section 02200, or where approved as extra work to fill voids or unclassified excavations approved by the Engineer. Select material backfill shall be placed where called for on in the Work Orders and Details, as specified, or as directed in the field. The work in this item includes compaction and

compliance with materials testing where dictated by the Engineer.

B. Measurement and Payment:

1. Measurement of work completed under this Bid Form item shall be the measured cubic yards of compacted select material backfill installed within the specified pay limits, which shall be measured as the sewer trench pay limit width multiplied by the number of linear feet of sewer spot repair installed, or the actual cubic yards of compacted select material backfill installed where approved in writing by the Engineer.
2. Payment under this Bid Form item shall be the measured cubic yards of compacted select material backfill installed within the specified pay limits, as measured by the Engineer.
3. If Engineer determines any work to be defective, deductions may be taken from the payment in accordance with GC Article 14.03-F.

1.13 BID FORM ITEM NO. 12 – ADDITIONAL STONE FOR UNDERCUT

A. Scope of Work

1. This Bid Form item includes all labor, materials, equipment, processes, products and other items required to install additional stone for undercut including installation of geotextile fabric.
2. The work in this item shall include all additional excavation, in open trenches, within sheeting boxes or within temporary sheeting, shoring and bracing, disposal of surplus excavated material; any additional sheeting required from the pipe invert to the trench bottom; providing and placing the geotextile fabric, placing and consolidating the additional stone, handling of water, including pumping and bailing; and all other work or expense required for a complete installation.

B. Measurement and Payment:

1. Measurement of work completed under this Bid Form item shall be the measured cubic yards of additional stone for undercut installed as directed by the Engineer for payment.
2. Payment under this Bid Form item shall be the cubic yards of additional stone for undercut, as measured by the Engineer.

3. If Engineer determines any work to be defective, deductions may be taken from the payment in accordance with GC Article 14.03-F.

#### 1.14 BID FORM ITEM NO. 13 – UNCLASSIFIED EXCAVATION AND DISPOSAL

##### A. Scope of Work

1. This Bid Form item includes all labor, materials, equipment, processes, products and other items required to perform unspecified excavation and disposal of materials not provided for under another Bid Form Item of these Specifications, at locations shown on the Drawings, identified in Work Orders, and as determined in the field or as directed in writing by the Engineer for the unit prices as stated in the Proposal. The work under this item does not include work that is to be included in the unit prices for sewer pipe under Bid Form Item Nos. 1 - 4, or manholes/catch basins under Bid Form Item No. 5.
2. Unclassified excavation shall consist of the excavation and disposal of all materials, of any description, encountered in the course of construction, unless otherwise specified in the contract. The unit prices stated in the Proposal shall include all additional excavation, handling, hauling and disposal of surplus excavated material being replaced by the select fill material or native soils, and all other work or expense required for a complete installation.

##### B. Measurement and Payment:

1. Measurement of work completed under this Bid Form item shall be the measured actual number of cubic yards of material excavated and disposed of, as directed by the Engineer for payment.
2. Payment under this Bid Form item shall be the actual number of cubic yards of material excavated and disposed of, as measured by the Engineer.
3. If Engineer determines any work to be defective, deductions may be taken from the payment in accordance with GC Article 14.03-F.

#### 1.15 BID FORM ITEM NO. 14 – ROCK EXCAVATION

##### A. Scope of Work

1. This Bid Form item includes all labor, materials, equipment, processes, products and other items required to excavate rock.

2. The term "rock" as used herein shall include all material requiring drilling and blasting, ripping, wedging, jack hammering or sledging and barring for their removal from their original beds and specifically includes materials classed as such in normal geological terminology and shall include all ledge or bed rock, solidified slag, boulders or masonry larger than one cubic yard (CY) in volume. Slag, boulders or masonry less than one cubic yard in volume shall not be measured for payment. It is the intention of these Specifications that soft rock material, which is mixed with clay, sands, loose gravel and silts and does not form a rock mass, shall not be included in this Bid Form Item.
3. Rock shall be excavated in general so that there will be a clean horizontal space of at least 12 inches from the inside barrel of the pipe, and 12 inches from the outside of the manhole base, chamber base or structure base to the rock surface. Rock shall be removed at least 6 inches below the outside barrel of the pipe at the invert.
4. After the rock has been removed from the trench and prior to placing the bedding material or pipe, the Engineer shall take measurements.

B. Measurement and Payment:

1. Measurement of work completed under this Bid Form item shall be the measured number of cubic yards of rock removed and disposed of, according to the payment lines specified above, or as directed by the Engineer for payment.
2. Payment under this Bid Form item shall be the measured number of cubic yards of rock, as measured by the Engineer.
3. If Engineer determines any work to be defective, deductions may be taken from the payment in accordance with GC Article 14.03-F.

1.16 BID FORM ITEM NO. 15 – TEST PIT EXCAVATION

A. Scope of Work

1. This Bid Form item includes all labor, materials, equipment, processes, products and other items required to excavate and backfill test pits, at locations as ordered by the Engineer for determining the exact nature and/or location of certain underground utilities or obstructions, or other purpose as required. All test pits shall be completed prior to the construction of proposed scheduled improvements.
2. The work under this item shall be in accordance with the detailed specification

requirements and shall include clearing, excavating, necessary shoring and bracing, and dewatering. If test pit is in lawn area, the work shall include backfill with excavated materials, grading, compaction, clean up and restoration. Work does not include lawn restoration included in Bid Form Item No. 20. If test pit location is in pavement or sidewalk, restoration shall be under Bid Form Item Nos., 6, 7, 11 and/or 17, as applicable.

3. The work under this item also includes making the necessary arrangements with the utility companies. The excavation of any test pits shall not relieve the Contractor of the responsibility for protection of utilities as detailed in the Specifications.
4. The Contractor shall Bid Form a unit price for a standard utility test pit of the sizes indicated (up to 4 cubic yards). If ordered by the Engineer, the Contractor will be paid for any utility test pit larger than this standard size in proportion to the unit price Bid Form for the standard utility test pit.
5. Where authorized by the Engineer, test pits made be performed via pneumatic excavation, and work shall be performed in accordance with NYSDOT Item 206.04020011.

B. Measurement and Payment:

1. Measurement of work completed under this Bid Form item shall be the number of utility test pits performed and directed by the Engineer for payment.
2. Payment under this Bid Form item shall be the number of utility test pits performed, as measured by the Engineer.
3. If Engineer determines any work to be defective, deductions may be taken from the payment in accordance with GC Article 14.03-F.

1.17 BID FORM ITEM NO. 16 – SEWER ABANDONMENT

A. Scope of Work

1. This Bid Form item includes all labor, materials, equipment, processes, products and other items required to abandon of pipes and/or manholes at locations identified in Work Orders or as ordered by the Engineer, and in a manner as specified in Section 02900. The abandonment work shall be for the applicable sub-items 16A through 16E as itemized on the Bid Form.
2. The work shall be inclusive of all excavations, backfill, bulkheads, standpipes,



pipe assemblies, etc. used by the Contractor to perform sewer abandonment, including but not limited to the following:

- a. Bid Form Item No. 16A (Abandon Existing Sewer – Bulkhead/Plug): All work for furnishing or placing plugs or bulkheads in sewers of various sizes and depths to be abandoned, including excavations where required.
- b. Bid Form Item No. 16B (Abandon Existing Sewer – Filling of Voids): All work for filling sewers of various sizes and depths with approved fill materials, including excavations, installation of standpipes, backfill, etc. where required.
- c. Bid Form Item No. 16C (Abandon Existing Sewer – Manholes (in Pavement)), Bid Form Item No. 16D (Abandon Existing Sewer – Manholes (in Lawn)), Bid Form Item No. 16E (Abandon Existing Sewer – Cleanout): All work for abandoning and backfilling manholes and cleanouts per Standard Details and Section 02900, including excavations, installation of standpipes, and backfill.

B. Measurement and Payment:

1. Bid Form Item No. 16A (Abandon Existing Sewer – Bulkhead/Plug): Measurement of work completed under this Bid Form item shall be the measured number of plugs/bulkheads installed as directed by the Engineer for payment. Payment under this Bid Form item shall be the number of plugs/bulkheads, as measured by the Engineer.
2. Bid Form Item No. 16B (Abandon Existing Sewer – Filling of Voids): Measurement of work completed under this Bid Form item shall be the measured cubic yards of approved fill material installed as directed by the Engineer for payment. Payment under this Bid Form item shall be the cubic yards of approved fill material, as measured by the Engineer.
3. Bid Form Item No. 16C (Abandon Existing Sewer – Manholes (in Pavement)): Measurement of work completed under this Bid Form item shall be the measured number of manholes abandoned as directed by the Engineer for payment. Payment under this Bid Form item shall be the number of manholes abandoned, as measured by the Engineer.
4. Bid Form Item No. 16D (Abandon Existing Sewer – Manholes (in Lawn)): Measurement of work completed under this Bid Form item shall be the

measured number of manholes abandoned installed as directed by the Engineer for payment. Payment under this Bid Form item shall be the number of manholes abandoned, as measured by the Engineer.

5. Bid Form Item No. 16E (Abandon Existing Sewer – Cleanout): Measurement of work completed under this Bid Form item shall be the measured number of cleanouts abandoned as directed by the Engineer for payment. Payment under this Bid Form item shall be the number of cleanouts abandoned, as measured by the Engineer.
6. If Engineer determines any work to be defective, deductions may be taken from the payment in accordance with GC Article 14.03-F.

#### 1.18 BID FORM ITEM NO. 17 – SIDEWALK AND DRIVEWAY RESTORATION

##### A. Scope of Work

1. This Bid Form item includes all labor, materials, equipment, processes, products and other items required to install new or replace existing driveways and sidewalks in-kind and quality. The restoration work shall be for the applicable sub-items 17A through 17F as itemized on the Bid Form.
2. The work shall consist of saw-cutting, excavation, disposal of excavated materials, brick/stone salvage as applicable, gravel sub-base, stone base, concrete, reinforcement, asphalt concrete, tack coat, install of embedded detectable warning unit panels, and all other work for a complete installation.
  - a. Bituminous macadam driveways shall be reconstructed with a minimum 4.5” thick pavement replacement.
  - b. Concrete driveways shall be reconstructed with minimum 6” thick reinforced concrete. Concrete sidewalks shall be reconstructed with minimum 4” thick reinforced concrete.
  - c. ADA Ramp detectable warning units (embedded) shall be installed or replaced where required to meet ADA standards, to replace existing, or where directed by the Engineer.

##### B. Measurement and Payment:

1. Measurement of work completed under this Bid Form item shall be the

measured number of square feet of sidewalk or driveway pavement, or detectable warning surface installed within the specified pay limits or where directed by the Engineer for payment.

2. Payment under this Bid Form item shall be the measured number of square feet, as measured by the Engineer.
3. If Engineer determines any work to be defective, deductions may be taken from the payment in accordance with GC Article 14.03-F.

1.19 BID FORM ITEM NO. 18 – CONCRETE CURB AND CURB RAMP RESTORATION

A. Scope of Work

1. This Bid Form item includes all labor, materials, equipment, processes, products and other items required to install new, or reset or replace existing curbing, gutter curbs, or curb ramps under the applicable sub-items 18A through 18H as itemized on the Bid Form.
2. For sub-items 18A through 18D, the Contractor shall furnish all labor, materials, tools and equipment required to reset or replace existing curbing or concrete gutter curb including sawcutting, excavation, disposal of excavated materials, stone salvage, grading, gravel base, concrete cradle and backing, formwork, stone curbing, concrete, reinforcement, grout, caulking, joint filler, expansion joints, and mortar, and restoration of adjacent roadway pavement as required to replace curbing. Curbing shall be replaced in kind unless otherwise ordered by the Engineer. This item shall include any new curbing ordered by the Engineer to be installed. For sewer trenches crossing perpendicular to the existing curbing/gutters, pay limits will equal the trench pay width plus 1'-0" on each side. The Contractor will be responsible for all curbing/concrete gutter repair costs disturbed by the construction and outside the designated pay limits. For sewer trenches parallel to the curb/concrete gutter, the extent of curb/concrete gutter scheduled for replacement will be identified in the Work Order or as directed by the Engineer. Curbing/concrete gutter that is not crossing through a sewer trench or is not identified for replacement shall be protected by the Contractor and restored at their expense.
3. For sub-items 18E through 18H, the Contractor shall furnish all labor, materials, tools and equipment required to replace or install curb ramps in accordance with the NYSDOT curb ramp configurations specified including sawcutting, excavation, disposal of excavated materials, stone salvage, grading, gravel base, concrete cradle and backing, formwork, stone curbing, concrete, reinforcement, grout, caulking, joint filler, expansion joints, mortar,

emdedded detectable warning unit placement, and restoration of adjacent roadway pavement as required to replace curbing.

B. Measurement and Payment:

1. Bid Form Items Nos. 18A through 18D (Curb/Gutter Restoration or Replacement): Measurement of work completed under this Bid Form item shall be the measured number of lineal feet of concrete gutter or curb installed within the specified pay limits or where directed by the Engineer for payment. Payment under this Bid Form item shall be the number of lineal feet of concrete gutter or curb, as measured by the Engineer.
2. Bid Form Items Nos. 18E through 18H (Concrete Curb Ramps): Measurement of work completed under this Bid Form item shall be the number of concrete curb ramps installed within the specified pay limits or where directed by the Engineer for payment. Payment under this Bid Form item shall be the number of concrete ramps, as measured by the Engineer. The Contractor's bid price shall be based on the following minimum square footage installations as follows:
  - a. Bid Form Item No. 18E (NYSDOT Type 1) - 80 SF of ramp including 8 LF of curb
  - b. Bid Form Item No. 18F (NYSDOT Type 4) - 100 SF ramp including 24 LF of curb
  - c. Bid Form Item No. 18G (NYSDOT Type 8) - 75 SF of sidewalk ramp inclusive of 15 LF curb
  - d. Bid Form Item No. 18H (NYSDOT Type 9) - 75 SF of sidewalk ramp inclusive of 15 LF curb

If the site configuration requires additional square footage of curb ramp replacement or installation, the Contractor will be paid for any curb ramp larger than the minimum size in proportion to the unit price Bid Form for the standard minimum curb ramp size.

3. If Engineer determines any work to be defective, deductions may be taken from the payment in accordance with GC Article 14.03-F.

1.20 BID FORM ITEM NO. 19 – CLEAR AND GRUB, TREE REMOVAL

A. Scope of Work

1. This Bid Form item includes all labor, materials, equipment, processes, products and other items required to clear and grub, remove shrubs or hedges, remove trees, and remove stumps, where directed in Work Orders or where approved by the Engineer for payment, for the various limits and under the applicable sub-items 19A through 19I as itemized on the Bid Form. The work

shall include backfill with excavated materials, grading, compaction, and site clean-up. Work does not include lawn restoration included in Bid Form Item No. 20.

B. Measurement and Payment:

1. Bid Form Items Nos. 19A and 19B (Clear and Grub): Measurement of work completed under this Bid Form item shall be the measured number of square yards of surface area cleared and grubbed as directed by the Engineer for payment. Payment under this Bid Form item shall be the measured number of square yards of surface area cleared and grubbed, as measured by the Engineer.
2. Bid Form Items Nos. 19C and 19D (Clear and Grub - Remove shrubs and Hedges): Measurement of work completed under this Bid Form item shall be the measured number of number of linear feet of shrubs, hedges, or other plants removed as directed by the Engineer for payment. Payment under this Bid Form item shall be the measured number of linear feet of shrubs, hedges, or other plants removed, as measured by the Engineer.
3. Bid Form Items Nos. 19E and 19H (Tree Removal), 19I (Tree Stump Removal and Re-Grade): Measurement of work completed under this Bid Form item shall be the measured actual number of trees or tree stumps removed as directed by the Engineer for payment. Payment under this Bid Form item shall be the measured number of trees or tree stumps removed, as measured by the Engineer.
4. If Engineer determines any work to be defective, deductions may be taken from the payment in accordance with GC Article 14.03-F.

1.21 BID FORM ITEM NO. 20 – LAWN RESTORATION – TOPSOIL AND SEED

A. Scope of Work

1. This Bid Form item includes all labor, materials, equipment, processes, products and other items required to furnish and perform lawn restoration and successfully establish grass including grading, topsoil, grass seed, fertilizer, mulch, mulch anchorage, hydroseeding, and maintenance as shown in the Work Orders and Details, as specified, or as ordered by the Engineer.

B. Measurement and Payment:

1. Measurement of work completed under this Bid Form item shall be the measured number of square feet of lawn area restored as directed by the

Engineer for payment.

2. Payment under this Bid Form item shall be the measured number of square feet of lawn area restored, as measured by the Engineer.
3. If Engineer determines any work to be defective, deductions may be taken from the payment in accordance with GC Article 14.03-F.

#### 1.22 BID FORM ITEM NO. 21 – TREE AND LANDSCAPING RESTORATION

##### A. Scope of Work

1. This Bid Form item includes all labor, materials, equipment, processes, products and other items required to plant trees or shrubs under the applicable sub-items 21A through 21B as itemized on the Bid Form.
2. The work shall include planting two- to three-inch diameter trees and 6' to 8' high (in varieties such as pine, oak, spruce); or 3-foot tall shrub or other plants; of the varieties specified (such as arborvitae), at locations directed by the Engineer or to replace trees removed and scheduled for replacement under the Work Order or Plans. Work shall include care and/or replacement up to one year after final acceptance of the Work Order.
3. Material costs for trees or shrubs shall be invoiced to the Owner with markups allowed per the General Contract Conditions.

##### B. Measurement and Payment:

1. Measurement of work completed under this Bid Form item shall be the measured number trees or shrubs/hedge plants installed as directed by the Engineer for payment.
2. Payment under this Bid Form item shall be the number trees or shrubs/hedge plants, as measured by the Engineer.
3. If Engineer determines any work to be defective, deductions may be taken from the payment in accordance with GC Article 14.03-F.

#### 1.23 BID FORM ITEM NO. 22 – MANHOLE/CATCH BASIN ADJUSTMENTS

##### A. Scope of Work

1. This Bid Form item includes all labor, materials, equipment, processes, products and other items required to adjust existing manhole rims or catch basin grates to grade, under the applicable sub-items 22A through 22B as

itemized on the Bid Form.

2. Manholes: The work shall include adjusting existing manhole rims (approximately 0 to 12-inches of vertical adjustment), or as required to be flush with existing roadway), including: sawcutting of pavement; excavation and backfill; removal and cleaning of existing manhole frame and cover and return to Owner; repair of existing walls; scarifying and/or removing or otherwise preparing top portion of existing walls; make necessary adjustments to existing manhole riser section to install manhole frame and cover to finished grade; installing riser rings of the required diameters and depths; installing new manhole frame and cover; concrete encasement; cleaning of existing manhole structure; and disposal of debris as described in the Work Order or specified, or as ordered by the Engineer.
3. Catch Basins: The work shall include adjusting existing catch basin elevations (approximately 0 to 6-inches of vertical adjustment, or as required to be flush with existing roadway), including: sawcutting of pavement; excavation and backfill; removal and cleaning of existing frame and grate; removal and cleaning of curbing; repair of existing walls; make necessary adjustments to existing catch basin to install manhole frame and grate to finished grade; forms; concrete; drill holes; reinforcing; grout; mortar mix; furnishing and installing new frame and grate; cleaning of existing catch basin; resetting of curbing; and disposal of debris as described in the Work Order or specified, or as ordered by the Engineer.
4. Asphalt pavement restoration is not included in this work and shall be paid under Bid Form Items No. 6, 7, and 17.
5. **The manhole frames and covers and concrete riser rings shall be provided by the Owner.** The frames and covers will be located at the respective Sewer District offices in which the spot repair is taking place, and it will be the Contractor's responsibility to pick them up at these locations.
6. If the vertical adjustment required exceeds the standard depth specified, the compensation will be in proportion to the unit price Bid Form for the standard manhole or catch basin adjustment.

B. Measurement and Payment:

1. Measurement of work completed under this Bid Form item shall be the measured number of manholes or catch basin frame adjustments completed as directed by the Engineer for payment.
2. Payment under this Bid Form item shall be the number of manholes or catch

basin frame adjustments completed, as measured by the Engineer.

3. If Engineer determines any work to be defective, deductions may be taken from the payment in accordance with GC Article 14.03-F.

#### 1.24 BID FORM ITEM NO. 23 – STORM UNDERDRAIN REPLACEMENT

##### A. Scope of Work

1. This Bid Form item includes all labor, materials, equipment, processes, products and other items required to remove and replace existing storm underdrain pipe and underdrain filter material within the installation pay limits, under the applicable sub-items 23A through 23B as itemized on the Bid Form. Materials and labor shall include underdrain pipe and pipe couplings in accordance the specifications or to match existing, including making all connections, and bedding stone. Work not included in this item includes excavation, backfill, and other work included in Bid Form Items No. 1, 2, 3, 4, and 5.

##### B. Measurement and Payment:

1. Measurement of work completed under this Bid Form item shall be the measured linear feet of underdrain replaced, which shall be measured along a horizontal plane along the centerline of the pipe for the length of spot repair completed
2. Payment under this Bid Form item shall be the linear feet of underdrain replaced, as measured by the Engineer.
3. If Engineer determines any work to be defective, deductions may be taken from the payment in accordance with GC Article 14.03-F.

#### 1.25 BID FORM ITEM NO. 24 – UTILITY SUPPORT

##### A. Scope of Work

1. This Bid Form item includes all labor, materials, equipment, processes, products and other items required to furnish, place, and remove temporary supports: 1) utilities crossing the trench excavation for the main sewer or for laterals, or 2) utility poles adjacent to or in close proximity to the trench excavation that require temporary support or protection, including by the utility, during the excavation work, and under the applicable sub-items 24A through 24D as itemized on the Bid Form.



2. The support of a utility is the act of supporting one or a group of utilities together crossing the excavation and shall include all the individual horizontal and vertical support components (system) necessary to provide the support. No payment will be made for support of utilities less than 4" in diameter.
3. Temporary tight sheeting included in this description shall be for the purpose of utility support only.
4. If Engineer determines any work to be defective, deductions may be taken from the payment in accordance with GC Article 14.03-F.

B. Measurement and Payment:

1. Bid Form Item No. 24A and 24B: Measurement of work completed under this Bid Form item shall be for each utility crossing the excavation which is supported as required by the utility agency. Payment under this Bid Form item shall be the number of utility crossings supported, as measured by the Engineer.
2. Bid Form Item No. 24C: Measurement of work completed under this Bid Form item shall be for number of square feet of temporary tight sheeting installed as required by the utility agency and approved by the Engineer as measured from the existing surface to the bottom of the excavation or the original rock surface, whichever is higher, and the horizontal length required by the utility agency. Payment under this Bid Form item shall be the square feet of temporary tight sheeting installed, as measured by the Engineer.
3. Bid Form Item No. 24D: Measurement for payment shall be for each temporary support of a utility pole as required due to proximity of the trench excavation to facilitate the work as required by the utility agency and approved by the Engineer.

1.26 BID FORM ITEM NO. 25 – CCTV INSPECTION OF SEWERS

A. Scope of Work

1. This Bid Form item includes all labor, materials, equipment, processes, products and other items required to install to perform internal video inspection of diameters indicated for gravity sanitary or storm sewer lines at the direction of the Owner and under the applicable sub-items 25A through 25C as itemized on the Bid Form. Work shall include submission of all video files along with a PDF report detailing any defect findings and recommendations to repair corresponding defects.

2. Bid Form Item No. 25A and 25B: The work shall consist of internal video inspection of sewers in accordance with Specification Section 02375 and shall include but not be limited to the following: mobilization/demobilization to/from locations specified in the Work Orders; protection of existing utilities; protection of traffic; required permits and fees; bulkheading and plugging of sewers, bypass piping, and bypass pumping systems; light flushing of sewers prior to televising, as required to facilitate a proper video; internal video inspection of cleaned sanitary sewers, including preparation of video logs and recording location of all sanitary sewer lateral connections, pipe defects, and blockages. Where light flushing of sewers prior to televising is not performed rendering the video of poor quality or preventing proper visual inspection of the features of the interior of the sewer, the Contractor shall be directed to repeat the video inspection and resubmit a new video before final payment is approved by the Owner.
3. Bid Form Item No. 25C: The work shall consist of perform a see-snake inspection at the direction of the Engineer to investigate laterals, connections, check pipe condition, or other exploratory work as directed by the Engineer, and shall include but not be limited to the following: mobilization/demobilization to/from locations specified in the Work Orders, use of pipe inspection equipment for exploratory purposes as directed and approved by the Engineer, use of a sonde to determine depths of pipelines, and assistance in collecting measurements and/or footages, and investigations shall be in the presence of the RPR or the Engineer.

B. Measurement and Payment:

1. For Bid Form Items No. 25A and 25B: Measurement of work completed under this Bid Form item shall be the measured linear footage from the center of manhole to center of manhole along the centerline of pipe section as directed by the Engineer for payment. In cases where video inspection of an entire section is not possible due to collapse or obstruction that cannot be removed by flushing or root cutting, measurement for payment shall be the actual lineal footage televised as determined from submitted video and approved by the Engineer for payment. Payment of the unit price stated in the Proposal for the number of total linear feet of sewer approved for payment shall constitute full payment for all work done under this Bid Form Item. Payment under this Bid Form item shall be the linear footage of sewer, as measured by the Engineer.
2. For Bid Form Items No. 25C: Measurement of work completed under this Bid Form item shall be the number of hours of inspection work, to the nearest one-half of an hour. The Owner shall determine the number of hours measured.

Payment under this Bid Form item shall be the number of hours, as measured by the Engineer.

3. If Engineer determines any work to be defective, deductions may be taken from the payment in accordance with GC Article 14.03-F.

1.27 BID FORM ITEM NO. 26 – TRAFFIC CONTROL – FLAGPERSON

A. Scope of Work

1. This Bid Form item includes all labor, materials, equipment, processes, products and other items required to perform dedicated flagging operations as required according to the Contractor's maintenance and protection of traffic plan or directed by the Engineer, and under the applicable sub-items 26A and 26B as itemized on the Bid Form. The flagperson shall be adequately trained in flagging operations.

B. Measurement and Payment:

1. Bid Form Item No. 26A: Measurement of work completed under this Bid Form item shall be the measured number of hours of a dedicated flagperson, to the nearest one-half of an hour. Overtime for flaggers shall be computed at time and one half for work days over 8 hours. Payment under this Bid Form item shall be the number of hours, as measured by the Engineer. Where five (5) consecutive work days (i.e., 40 hours) of a flagperson onsite is met or exceeded, payment shall be under Bid Form Item No. 26B.
2. Bid Form Item No. 26B: Measurement of work completed under this Bid Form item shall be the measured number of weeks of a dedicated flagperson. Where five (5) consecutive work days (i.e., 40 hours) of a dedicated flagperson onsite is met or exceeded, payment shall be under this Bid Form Item. Overtime for flaggers shall be computed at an hourly rate under Bid Form Item No. 26A where applicable. Payment under this Bid Form item shall be the number of weeks, as measured by the Engineer.
3. If Engineer determines any work to be defective, deductions may be taken from the payment in accordance with GC Article 14.03-F.

1.28 BID FORM ITEM NO. 27 – TRAFFIC CONTROL WORK ZONES AND DEVICES

A. Scope of Work

1. This Bid Form item includes all labor, materials, equipment, processes, products and other items required to provide traffic control devices or controls enumerated on an as-needed basis, according to the Contractor's maintenance and protection of traffic plan or where directed or approved by the Engineer and/or the roadway owner, and under the applicable sub-items 27A through 27J as itemized on the Bid Form. Devices/controls/equipment applicable to this Bid Form Item include: portable advance warning arrow panels, portable traffic signals, attenuator trucks, and Type III barricades. Traffic control devices, work zones or lane closures outside the scope of the controls/devices listed above shall be compensated at invoiced rental costs plus allowable overhead and profit markups per the General Conditions. The devices, controls, or equipment shall be a recent model in good repair and operating condition. The only compensation for use of the above listed devices/controls/equipment shall be at the applicable unit prices even if the devices/controls are included as part of comprehensive traffic control work zone plan, unless approved in writing by the Engineer.
2. Bid Form Item No. 27I: This Bid Form item is intended to be compensated for project sites that include work on a NYSDOT or County roadway requiring an approved traffic control plan by the roadway owner AND including one or more of the above listed controls/devices as part of the approved plan. The work shall consist of the delivery of control/devices in sub-items 27A through 27H to the project site (various locations) and shall be inclusive of one-time set up and take down of the devices. The price shall be inclusive of applicable sales tax and off-hours delivery fees. There will be no separate payment for maintenance of devices during construction. The Contractor's bid price shall be based on the following assumptions: a work zone on a County or NYSDOT roadway required to complete a minimum length spot repair.
3. Bid Form Item No. 27J: This work is defined as a condition when the Contractor is required to prepare a traffic control plan as part of the roadway owner's (i.e, County or NYSDOT) highway permit application process. Reimbursement for the traffic control plan preparation shall be made under this Bid Form item upon receipt of plan and subcontractor invoice. Reimbursement shall only be made for traffic control plans made in conformance with N.Y.S. Manual of Uniform Traffic Control Devices.
4. Measurement and Payment:

5. Measurement of work completed under this Bid Form item shall be per each (maximum once per work order). Payment under this Bid Form item shall be the per each, as measured by the Engineer.
6. Payment under this Bid Form item shall be per each, as measured by the Engineer.
7. If Engineer determines any work to be defective, deductions may be taken from the payment in accordance with GC Article 14.03-F.

B. Measurement and Payment:

1. Bid Form Item Nos. 27A, 27C, 27E, & 27G: Measurement of work completed under this Bid Form item shall be the number of days the devices are onsite and in use, to the nearest one-half of a day (equivalent to four (4) hours). Overtime for traffic control devices shall be computed as straight time (one eighth of the daily rate, one fortieth of the weekly rate, etc.) for each hour over 8 hours. Payment under this Bid Form item shall be the number of days, as measured by the Engineer.
2. Bid Form Item Nos. 27B, 27D, 27F, & 27H: Measurement of work completed under this Bid Form item shall be the number of weeks the devices are onsite and in use. Overtime for traffic control devices shall be computed as straight time (one eighth of the daily rate, one fortieth of the weekly rate, etc.) for each hour over 8 hours. Payment under this Bid Form item shall be the number of weeks, as measured by the Engineer.
3. Bid Form Item No. 27I: Measurement of work completed under this Bid Form item shall be per each for one-time delivery of designated traffic control devices, set up and take down of devices/work zone as required per approved traffic control plans for project sites that include work on a NYSDOT or County roadway.
4. Bid Form Item No. 27I: Measurement of work completed under this Bid Form item shall be per each for one-time development of a traffic control plan for project sites that include work on a NYSDOT or County roadway.

1.29 BID FORM ITEM NO. 28 – ASBESTOS ABATEMENT, HANDLING, AND DISPOSAL

A. Scope of Work

1. This Bid Form item includes all labor, materials, equipment, processes,

products and other items required to perform asbestos handling and abatement at the locations indicated on the Plans and in accordance with the Specifications, and all federal, state, local, regulations governing asbestos abatement, and under the applicable sub-items 28A and 28B as itemized on the Bid Form. Proof of proper disposal and subcontractor invoice is required before payment will be reimbursed.

B. Measurement and Payment:

1. Bid Form Item No. 28A: Measurement of work completed under this Bid Form item shall be the measured number of hours. Payment under this Bid Form item shall be the number of hours, as measured by the Engineer, **for a minimum of four (4) hours.**
2. Bid Form Item No. 28B: Measurement of work completed under this Bid Form item shall be the measured number of days, for a **minimum of one (1) day (equivalent to 8 hours).** Payment under this Bid Form item shall be the number of days, as measured by the Engineer.
3. If Engineer determines any work to be defective, deductions may be taken from the payment in accordance with GC Article 14.03-F.

FIXED BID PRICE ITEMS

1.30 BID FORM ITEM NO. 29 – DOWNTIME (DIRECTED BY OWNER) – FIXED PRICE

A. Scope of Work

1. The work of this item is defined as the period of time when the Contractor is directed by the Owner to temporarily stop work (downtime) for the Owner's conveniences or provide direction to the Contractor. The period of time will be as determined by the Owner. The downtime shall include all labor and equipment utilized on the project site. This Bid Form item has a fixed price.

B. Measurement and Payment:

1. Measurement of work completed under this Bid Form item shall be the measured number of hours, to the nearest one-half of an hour installed as directed by the Engineer for payment.
2. Payment under this Bid Form item shall be the number of hours, as measured by the Engineer.

1.31 BID FORM ITEM NO. 30 - MOBILIZATION – FIXED PRICE

A. Scope of Work

1. The work of this item is mobilization under the applicable sub-items 30A and 30B as itemized on the Bid Form. This Bid Form item has a fixed price.
2. Bid Form Item No. 30A (Mobilization to Project Site – Once per Work Order – Fixed Price): This Bid Form item is intended to be compensated once per each Work Order issued for the work to mobilize labor, materials, and equipment to project sites at various locations throughout Erie County, New York in Erie County Sewer District Nos. 1, 2, 3, 4, 5, 6, and 8. There will be no separate payment for demobilization.
3. Bid Form Item No. 30B (Mobilization as Directed by Owner (Between Erie County sites) – Fixed Price): This work is defined as a condition when the Owner directs the Contractor to mobilize materials and equipment from a project site where work is being performed to a second project site to perform work for the convenience of the Owner. Mobilization means the act of transporting materials and equipment from one project site to another. There will be no additional payment for return of materials and equipment to the original site. There will be no separate payment for demobilization from the original site.

B. Measurement and Payment:

1. Bid Form Item No. 30A (Mobilization to Project Site – Once per Work Order – Fixed Price): Measurement of work completed under this Bid Form item shall be per each (once per work order). Payment under this Bid Form item shall be the per each, as measured by the Engineer.
2. Bid Form Item No. 30B (Mobilization as Directed by Owner (Between Erie County sites) – Fixed Price): Measurement of work completed under this Bid Form item shall be the measured number of hours, to the nearest one-half of an hour. Payment under this Bid Form item shall be the number of hours, as measured by the Engineer.

1.32 BID FORM ITEM NO. 31 – CONSULTING/SITE VISITS – FIXED PRICE

A. Scope of Work

1. This work is defined as a condition when the Owner directs the Contractor to visit a project site for the purposes of reviewing a scope of work, preparation or discussion related to a future work assignment, or other consultation as requested by the Engineer prior to mobilization. This Bid Form item has a fixed price.

B. Measurement and Payment:

1. Measurement of work completed under this Bid Form item shall be the measured number of hours, to the nearest one-half of an hour installed as directed by the Engineer for payment. The payment will be in actual hours, regardless of the number of representatives the Contractor has onsite for the meeting (i.e., no additional payment for additional representatives).
2. Payment under this Bid Form item shall be the number of hours, as measured by the Engineer.

PART 2 PRODUCTS

NOT USED

PART 3 EXECUTION

NOT USED

END OF SECTION



**SECTION 01 25 13**  
**PRODUCT SUBSTITUTION PROCEDURES**

PART 1 GENERAL

1.1 SUMMARY

- A. This section includes the procedure for proposing alternate or substitute products without impacting the design intent of the Work. This Section supplements GC Article 7.06.
- B. Substitutions can only be requested after the Notice of Award. Contractor must base their Bid on specified materials, equipment, processes and products.

1.2 GENERAL

- A. Substitutions will not be considered when submitted as a shop drawing without indication that the product is a substitution, when substitution is requested directly by a Subcontractor or supplier, or when acceptance will require substantial revision of the Work Order. Substitutions shall be formally requested by following the procedures in item 1.4 Substitution Procedure.
- B. Engineer and Owner reserve the right to require substitute items to comply in color and pattern with specified items, if necessary to secure design intent.
- C. Contractor shall have the burden of proving the substitutions comply with the design intent, at his own expense, to the satisfaction of Engineer and Owner.
- D. Contractor shall make no claim for an extension of the time or for damages by reason of the time taken by Engineer in considering a substitution proposed by the Contractor, or by reason of the failure of Engineer to review a substitution proposed by Contractor.
- E. Where the approval of a substitution requires revision or redesign of any part of the Work, all such revision and redesign, and all new drawings, and details required therefore, shall be subject to the review of Engineer and shall be provided by Contractor at his own cost and expense.
- F. Engineer may recommend rejection or acceptance of a substitution, based on their knowledge and experience, without evaluation.
- G. Contractor can withdraw a proposal for substitution at any time. Contractor may still be responsible for Engineer's fees in evaluating the substitution.

1.3 CONTRACTOR REPRESENTATION

- A. The request for substitution constitutes a representation that Contractor:
1. Has investigated proposed product and determined that meets design intent and has comparable longevity, or is superior in all respects to specified product.
  2. Shall provide, as a minimum, the same warranty for the substitution that would be supplied for the specified product.
  3. Shall coordinate installation of an accepted substitute, making such changes as may be required to the Work to accommodate the substitution, in every respect.
  4. Certifies that the cost data presented is complete and includes all related costs. Contractor certifies that any savings realized by the substitution is presented in the substitution proposal.
  5. Waives claims for additional costs related to the substitution that may later become apparent.
  6. Contractor has determined the existence of any patents, trademarks, or copyrights associated with the substitution and included any fees, royalties or claims associated with such.
    - a. Contractor is responsible to provide a suitable written agreement with the patentee, patent owner, copyright owner, or trademark owner which shall provide that there will be no future or continuing royalties or payments by Contractor or Owner.
    - b. Contractor shall pay all applicable royalties and license fees.
    - c. Contractor and surety shall indemnify Owner and Engineer from all fees, royalties and claims or suits in connection with any infringement or alleged infringement of patent rights, copyrights, or trademark rights.
- B. By submitting the substitution, Contractor is agreeing to incur all costs associated with such a substitution.
- C. Contractor will not order or install any substitutions without written acceptance from Engineer or Owner. Substitute products ordered or installed without written acceptance will be at Contractor's risk. Contractor is liable for all costs associated with replacement of such products if not accepted.

#### 1.4 SUBSTITUTION PROCEDURE

- A. Any time after the Notice of Award has been issued, but before evaluation will impact the Progress Schedule, Engineer will consider written requests for substitutions of materials, equipment, processes, products, or other items.
- B. Contractor shall submit separate requests for each substitution. Document each request with data substantiating compliance and compatibility of proposed substitution with requirements of the Contract Documents.
- C. Contractor shall identify product by Specification's section and article numbers and provide the following information:
  - 1. Manufacturer's name, address, and phone number, trade name of product, and model or catalog number. List fabricators and suppliers as appropriate.
  - 2. All information as indicated in Section 01 33 10 Submittal Procedures.
  - 3. An itemized comparison of proposed substitution with specified product, listing variations, and reference to specification's section and article numbers.
  - 4. A quality and performance comparison, positive and negative, between proposed substitution and the specified product. Differences shall be clearly listed, highlighted or otherwise emphasized. Differences include, but are not limited to, operational type, weight, thickness, size, materials of construction, strength, elasticity, or method of installation. Samples must be provided where applicable.
  - 5. Design Life (the time life span of the product used in the Work, as determined by Engineer), and data and information that can be used to support or determine Design Life.
  - 6. Service Life (the time life span of equipment or material before failure occurs or before the cost of maintenance justifies replacement, as determined by Engineer), and data, references, and information that can be used to support or determine Service Life.
  - 7. Expected maintenance, replaceable components, and cost of replacement components. Include years that company has been in business, location of replacement parts center, location of manufacturer's service center, typical time for receipt of parts, shipment cost to project location, and manufacturer's representative information.
  - 8. Cost data comparing proposed substitution with specified product, and the amount of net change to the Contract Price. Savings in cost resulting from such substitutions proposed to be passed onto Owner shall be identified.

9. Effect of substitution on progress schedule and Contract Time and changes required in other work or products, including impacts on other Contracts.
- D. Engineer may make inquiries into Contractor's expertise, authorization and training regarding installation of the product, equipment or material. Contractor shall provide all information for such inquiries and authorize the Engineer to access such information.
- E. If no change to Contract Price and Contract Time is required, Engineer will indicate approval or rejection of the requested substitution(s) in writing.
- F. If an increase in Contract Price or Contract Time is required, Engineer will make a recommendation and Owner's written approval or disapproval will be required.

#### 1.5 OWNER APPROVAL

- A. Owner approval is required when the substitution will result in an increase Contract Price or Contract Time. The substitution will then be considered a Change Proposal submitted by the Contractor for purposes of the Contract.
- B. If Owner's approval is required, Owner will make the final determination, in writing, whether to approve or reject the substitution(s).
- C. If the substitution is approved, the Work will be changed accordingly and a Change Order will be required to change the Contract Price or Contract Time.
- D. If the substitution is rejected, Contractor shall furnish products, materials, processed and equipment specified in the Contract Documents. Contractor may still be required to pay Engineer's expenses.

### PART 2 PRODUCTS

NOT USED

### PART 3 EXECUTION

#### 3.1 ENGINEER INSPECTION

- A. Contractor shall notify Engineer as soon as approved substitute products, materials, processes or equipment are available for inspection. Engineer shall inspect all substitutes for conformance with substitution approvals, prior to installation.
- B. If Contractor fails to notify Engineer that materials, equipment or products are approved substitutes prior to installation, Contractor will be responsible making

all substitution components available for inspection. Actions required to make products available may include, without limitation, excavation, disassembly, removal, disconnection, raising, lowering, or removal of other placed materials such as concrete.

- C. If Engineer finds that substitution is not of the type or quality of what was represented or approved, Contractor is responsible for providing the approved substitution, making other adjustments stipulated by Engineer for substitution to be acceptable for use in the Work, or providing the specified equipment, materials, processes or products. Contractor shall credit the Owner with any additional Engineering costs due to changes after approval.

### 3.2 PERFORMANCE TEST

- A. If the substitution should fail or not perform up to the design standards, Owner can order its replacement at no additional cost to the Owner. Upon receipt of such a request, the Contractor will immediately replace said substitute with the materials, equipment, process or product specified in the Contract Documents.

END OF SECTION

**SECTION 01 26 10  
CONTRACT MODIFICATION PROCEDURES**

PART 1 GENERAL

1.1 SUMMARY

- A. This section includes the procedures for proposing, initiating, or authorizing contemplated changes to the Contract.
- B. Related Sections:
  - 1. Section 01 21 06 – Contingency Allowances
  - 2. Section 01 25 13 – Product Substitution Procedures

1.2 DEFINITIONS

- A. Request for Proposal (RFP): Written or verbal request by Engineer or Owner to Contractor that asks for information pertinent to Owner's contemplated changes to the Work.
- B. Request for Information (RFI): Contractor request for clarification on design documents that will not necessarily create a change to the Contract.
- C. Request for Change (RFC): Written or verbal inquiry to Engineer by Contractor that asks for potential changes to the Work.

1.3 GENERAL

- A. RFPs consist of proposed changes to the Work that may or may not be performed. Formal changes to the Work are made through Work Change Directives, as defined in GC Article 1.01-A.50, or Field Orders, as defined in GC Article 1.01-A.23.
- B. RFIs do not include changes to the Work. If Contractor believes the information or clarification received from Engineer in response to an RFI constitutes a change to the Work, a Change Proposal, as defined by GC Article 1.01-A.9, should be submitted with the resulting change clearly defined.
- C. RFCs are made for potential changes to the Work that are suggestions or recommendations by Contractor that is different from the design of the Engineer. Any addition or loss of cost or time must be identified and, if the RFC is accepted, a Change Proposal must be submitted. Change Proposals will not be considered that include costs listed in GC Article 13.01-C.
- D. An RFP or RFC can be withdrawn at any time without penalty.

- E. Engineer can direct or request changes to technical components of the Work that do not require modification of the Contract. All changes that will require modification of the Contract must be approved or accepted by Owner.

#### 1.4 ENGINEER PROPOSED CHANGES

- A. Engineer or Owner may issue an RFP to Contractor to evaluate the impact of a potential change on the Work, Contract Time and Contract Price. Such a request is not an authorization to perform such work or to stop work in progress unless the request explicitly states such intent.
- B. Engineer or Owner will supply the following information related to the RFP:
  - 1. Description of the proposed change, products or processes required in the change and location of the change.
  - 2. Supplementary or revised Contract Drawings and Specifications.
  - 3. Projected time span for making the change.
- C. Upon receipt of the RFP from Engineer or Owner, Contractor shall provide a proposal within 7 days, or another timeframe outlined in the RFP. The proposal shall contain the following information:
  - 1. Impacts the proposed change will have on project schedule with emphasis on the impacts on the schedule's critical path.
  - 2. Time frame required to make the requested changes, including if overtime will be required to make the change.
  - 3. Impacts, if any, the proposed changes will have the Contract Price.
  - 4. Additional materials, equipment, labor, processes, products or other items that would be required to make the requested change.
  - 5. Other impacts that the change may have on the Work that has not been indicated in the RFP.
- D. After receiving the Contractor proposal, Engineer will do one or more of the following, within 7 days:
  - 1. Notify Contractor if the change will not be implemented.
  - 2. Issue a Field Order instituting all or part of the change.
  - 3. Request a Work Change Directive from Owner instituting all or part of the change.

#### 1.5 CONTRACTOR PROPOSED CHANGES

- A. Contractor may submit an RFC to Engineer to request evaluation of a potential addition to, subtraction from, or change in the Work.

- B. Contractor will supply the following information related to the RFC:
  - 1. Products and processes involved in the change. References to Contract Documents, such as where work is shown on the Drawings and detailed in the Specifications, is required.
  - 2. Description of materials, equipment, labor, processes, products or other items that would be required to make the requested change.
  - 3. Projected time frame for making the change and impacts the proposed change will have on project schedule, including impacts on the schedule's critical path and if overtime will be required to make the change.
  - 4. Impacts, if any, the proposed changes will have on the Contract Price.
  - 5. Impacts that the change will have on Owner operations or other Contracts.
- C. Upon receipt of the RFC from Contractor, Engineer will review the proposal to determine if the change would be a substitution. If so, Contractor must follow the requirements and procedures in Section 01 25 13 Product Substitution Procedures.
- D. Engineer will determine if all or part of the RFC will require Owner approval. If Owner approval is required, Engineer acceptance or rejection will be provided in the allotted timeframe. Owner approval will require additional time.
- E. Engineer will have up to 7 days to respond to the RFC. Contractor may request a response in a shorter timeframe and Engineer may respond in that timeframe, if possible. Engineer response will indicate acceptance or rejection of the request.
- F. Engineer may defer a decision. Acceptance or rejection will be deferred if the change is dependent upon the result of some portion of the Work that has not yet been performed. Contractor can withdraw their request instead of accept deference.
- G. If Engineer rejects the change:
  - 1. It will have no impact on the Work.
  - 2. The reason for rejection will be given.
  - 3. The decision will be final.
- H. If Engineer accepts the change, Engineer will do one or more of the following:
  - 1. Notify Contractor if any portions of the change will be modified.
  - 2. Issue a Field Order instituting all or part of the change.
  - 3. Request a Work Change Directive from Owner instituting all or part of the change.
  - 4. Request Contractor submit a Change Proposal for all or part of the change.

## 1.6 FIELD ORDERS



- A. Engineer will issue Field Orders in accordance with GC Article 11.04. Field Orders, by definition, do not change the Contract Price or Contract Time and may require modifications to the Contract.

#### 1.7 WORK CHANGE DIRECTIVES

- A. Engineer may recommend changes in the Work to Owner or Owner may require addition, deletion or changes to the Work. Owner may issue a Work Change Directive in accordance with GC Article 11.03.
- B. Work Change Directives will include the following:
  - 1. Description of the proposed change, materials, equipment, labor, processes, products or other items required in the change.
  - 2. Location of the change.
  - 3. Supplementary or revised Contract Drawings and Specifications.
  - 4. Projected time span for making the change, expected impacts the change will have on project schedule, and expected time required to make the requested change, including if overtime will be required.
  - 5. The estimate changes, if any, to the Contract Price.
- C. Whenever possible, changes to Contract Price and Contract Time will be negotiated between Owner and Contractor prior to, or immediately following, the issuance of the Work Change Directive.
- D. Work Change Directives that change Contract Price and Contract Time will be included in a subsequent Change Order.

#### 1.8 CHANGE PROPOSALS

- A. Contractor may submit a Change Proposal related to changes in the Work in accordance with GC Article 11.09.
- B. Whenever possible, changes to Contract Price and Contract Time shall be negotiated between Owner and Contractor prior to the submittal of a Change Proposal.
- C. Change Proposals requesting a change to Contract Price and Contract Time will be submitted on Contractor company letterhead, with the total changes clearly indicated.
- D. Changes to Contract Time must be submitted prior to the end of Contract Time.
- E. Approved Change Proposals that change the Contract Price or Contract Time will be included on a subsequent Change Order.

## 1.9 CHANGE ORDERS

- A. Owner may authorize changes in work in accordance with GC Article 11.05.
- B. If a Work Change Directive or Change Proposal increases or decreases the Contract Price or Contract Time, an equitable adjustment will be authorized by Change Order in accordance with GC Article 11.02.
- C. A Change Order may contain multiple changes, directives, or proposals.
- D. Payment for changes in Contract Price may be taken out of a contingency allowance instead of issuing a Change Order. See Section 01 21 16 Contingency Allowances for information on contingency allowances. Such payments will be summarized in the final Change Order to close the Contract.
- E. Depending on the degree of impact and timing of the Work Change Directive or Change Proposal, changes in Contract Time and Contract Price may be included in the final Change Order to close the Contract rather than an executed Change Order during the Contract.
- F. Contractor may request the execution of a Change Order during the Contract that includes a change in Contract Price but does not involve payment from a contingency allowance.
- G. Change Orders will be executed using the following procedure:
  - 1. If required, Engineer will recommend the change, in writing, to Owner and provide all supporting documentation to Owner and Contractor to identify and explain the change.
  - 2. Owner will approve the change in Contract Price and Contract Time, in writing, and provide Change Order forms.
  - 3. Contractor shall execute Change Order forms in triplicate, signifying Contractor acceptance of the change.
  - 4. Engineer will sign all Change Order forms and return to Owner.
  - 5. Owner will execute Change Order forms in triplicate and return one original copy to each interested party.
- H. Change Orders may require additional Owner approvals, including, without limitation, other County Departments and the Erie County Legislature, depending on the extent of the change. A timeframe for Owner execution of a Change Order cannot be guaranteed.
- I. Payment under the Change Order will not be available until the Change Order is fully executed.

PART 2 PRODUCTS

NOT USED

PART 3 EXECUTION

NOT USED

END OF SECTION

**SECTION 01 29 73**  
**SCHEDULE OF VALUES**

PART 1 GENERAL

1.1 SUMMARY

- A. This section includes the procedures for preparing and submitting the Schedule of Values.
- B. Related Sections:
  - 1. Section 01 20 13 – Lump Sum Measurement and Payment
  - 2. Section 01 22 13 – Unit Price Measurement and Payment
  - 3. Section 01 29 76 – Progress Payment Procedures

1.2 GENERAL

- A. The Schedule of Values will be the basis for measurement and payment as detailed in Section 01 20 13 Lump Sum Measurement and Payment and Section 01 22 13 Unit Price Measurement and Payment.
- B. The Schedule of Values will be submitted with each request for progress payment indicating completed work as detailed in Section 01 29 76 Progress Payment Procedures.
- C. If any item of work listed on the Schedule of Values is removed from the Work, Owner will be credited the entire amount listed. The amount of credit may be reduced by any amounts already paid to Contractor, if work has been performed and approved on the item prior to removal from the Contract.

1.3 FORMAT

- A. Schedule shall follow AIA Document G703 – Continuation Sheet for Application and Certificate for Payment or other mutually agreed upon standard format.
- B. List component parts and identify each line item by number and title of major Specifications Section.
- C. All bid items must be listed separately, including contingency allowance items.

1.4 CONTENT

- A. Identify the Project by the Erie County Sewer District (ECSD) Number and Contract Number assigned by Owner.
- B. List installed value of each major item of the Work and each subcontracted item

of Work as separate line items, rounding off values to nearest dollar.

- C. List contingency allowance and other allowances with the specified monetary amounts for each allowance in separate divisions. List approved proposals as separate lines under the appropriate contingency allowance.
- D. Contractor may use separate lines for bonds, insurance, temporary facilities and controls, superintendents, and mobilization. Each item shall include pro rata portion of overhead and profit.
- E. Break all major equipment costs into equipment and materials/labor at a minimum.

#### 1.5 ACCEPTANCE

- A. Contractor is responsible for ensuring that the Schedule of Values is a reasonable allocation of the Contract Price.
- B. Engineer or Owner may request information to substantiate any line item. Contractor shall submit justification upon request.
- C. Engineer or Owner may request reallocation of prices on listed items.
- D. Acceptance of the Schedule of Values does not constitute approval for payment of any of the items listed.

#### PART 2 PRODUCTS

NOT USED

#### PART 3 EXECUTION

NOT USED

END OF SECTION

**SECTION 01 29 76**  
**PROGRESS PAYMENT PROCEDURES**

PART 1 GENERAL

1.1 SUMMARY

- A. This section includes the requirements associated with payments, and procedures for preparing and submitting applications for progress payments.
- B. Related Sections:
  - 1. Section 01 20 13 – Lump Sum Measurement and Payment
  - 2. Section 01 22 13 – Unit Price Measurement and Payment
  - 3. Section 01 29 73 – Schedule of Values
  - 4. Section 01 77 19 – Closeout Procedures

1.2 DEFINITIONS

- A. Basic Rate of Pay: The rate actually payable to the worker, which may be higher but not lower than the minimum wage set forth in the Prevailing Rate Schedule.
- B. Pencil Copy: A submittal from Contractor to Engineer containing, at a minimum, the accepted form of the Schedule Values with the proposed amount of work completed and equipment accepted that are available for payment in the pay period. Pencil Copy must include a summary of the total Contract amount in the application, retention to be withheld, and total payment requested.
- C. EEO Programs: Programs administered by the Erie County Office of Equal Employment Opportunity (EEO) that are included in the Contract. Programs include, but are not limited to, employment initiatives, minority-owned business enterprises (MBE) goals, women-owned business enterprises (WBE) goals, service-disabled veteran-owned business (SDVOB) goals, apprenticeship requirements, local law requirements, and executive order requirements.

1.3 GENERAL

- A. Measurement and payment of individual bid items are detailed in Section 01 20 13 Lump Sum Measurement and Payment and Section 01 22 13 Unit Price Measurement and Payment. Measurement and payment under contingency allowances will only be for approved items, as described in those sections.
- B. Payment for lines that include labor, materials, equipment, processes, or products necessary for the duration of the Work, including but not limited to temporary facilities, temporary utilities, supervision or management, will be paid at a percentage to equal the overall percentage of the progress of the Work.

- C. In accordance with the Agreement, partial payments may be made for materials and equipment not incorporated in the Work if sufficient documentation is received to prove that the materials and equipment have been received by Contractor and Contractor has been invoiced or paid the supplier. Engineer may request additional documentation. Owner reserves the right to inspect, or have inspected on the Owner's behalf, any materials or equipment before payment is approved.
- D. If mobilization is included with other components of work, mobilization will be paid the appropriate percentage of the progress of the other work.
- E. Work in excess of 8 hours per day or 40 hours per week must obtain dispensation and shall be compensated at a minimum of one and one-half (1½) times the Basic Rate of Pay for all hours worked in excess of 8 hours, on any one day, or in excess of forty hours in any one week. This shall not limit agreements to the contrary or mandatory overtime compensation in excess of those stipulated amounts. Such extra compensation shall not constitute a claim for additional compensation under this Contract.

#### 1.4 PREVAILING RATE SCHEDULE

- A. All workers must be paid, at a minimum, the rate listed in the Prevailing Rate Schedule specific to this project. Refer to Section 00 73 43 Wage Rate Requirements for requirements.
- B. Employees cannot be paid apprentice rates unless they are individually registered in a program that is registered with the New York State Commissioner of Labor. An employee listed on a payroll as an apprentice who is not registered or is performing work outside the classification of work for which the apprentice is indentured, must be paid the prevailing journey worker's wage rate for the classification of work the employee is actually performing.
- C. Payment cannot be made for laborers, workers, or mechanics in the employ of Contractor or Subcontractor engaged in the performance of any public work project for more than 8 hours in any day or 40 hours in any week, unless a dispensation has been obtained. Contractor and Owner have to apply to the for a dispensation permitting workers to work additional hours prior to work being performed.
- D. The wages and supplements contained in the annual determination become effective July 1st whether or not the new determination has been received by Contractor. Care should be taken to review the rates for obvious errors. Any corrections should be brought to the DOL's attention immediately. It is the responsibility of Contractor to use the proper rates. Annual determinations will be

corrected and posted to the DOL's website on the first business day of each month. Contractors are responsible for paying these updated rates as well, retroactive to July 1st.

- E. Contractor is responsible for any underpayments of prevailing wages or supplements by their Subcontractor.
- F. The Public Work Project notice must be posted at the beginning of the performance of the Work on each Site.
- G. Payroll records must be kept for three years from the Project's date of completion.

#### 1.5 APPLICATION MATERIALS

- A. Owner has standard forms for payment application. A copy of the Schedule of Values indicating the completed work shall accompany each pay application form. Requirements for the Schedule of Values are detailed in Section 01 29 73 Schedule of Values. The Schedule of Values shall be in the format accepted in the initial submittal.
- B. Updated information for each of the applicable EEO Programs shall be submitted. Forms shall be submitted as indicated the individual sections pertaining to these programs. Requirements may include electronic submissions associated with an applicable EEO Program.
- C. Payrolls certifying compliance with the Prevailing Rate Schedule shall be submitted with each payment application in accordance with Section 00 73 43 Wage Rate Requirements. Subcontractors are required to submit paper copy certified payrolls for only the time spent on the project. Electronic payroll submissions may require negative reports from Subcontractors for times when no actual work is being performed.
- D. Insurance certificates must be current for payment to be authorized. Any updated insurance certificates shall be submitted to ensure payment.

#### 1.6 PROCEDURE

- A. Contractor shall submit the Pencil Copy to Engineer. Owner must be notified that a pencil copy is submitted.
- B. Engineer will request changes to the Pencil Copy or will recommend payment as submitted. Engineer may ask for supporting documentation for items for which payment is requested.
- C. Engineer will notify both Contractor and Owner of recommendations in



accordance with GC Article 15.01-C.

- D. If Owner agrees, Owner will send appropriate forms to Contractor.
- E. Contractor will submit appropriate forms for payment application approval and required application materials. Contractor will send forms to Engineer for approval.
- F. Engineer will indicate their approval and send forms to Owner.
- G. Contractor will send other required application materials directly to Owner.
- H. Once all application materials are received and reviewed, Owner will process payment.

#### 1.7 RETENTION

- A. The amount retained in each pay request shall be as outlined in the Agreement.
- B. Retention shall be eligible for release when all the Work contained in the Work Order is complete, regardless of the completion of any individual Bid Form, Work Order, or Contract item.
- C. When requesting a reduction of retainage, Contractor will provide Owner with a letter of consent from his surety company.
- D. Refer to Section 01 77 19 Closeout Procedures for information on the requirements for final payment of retention.

#### 1.8 WITHHOLDING PAYMENT

- A. Owner may withhold from Contractor payments according to GC Article 15.01-E.
- B. When a complaint is filed with the Commissioner of Labor alleging the failure of Contractor or subcontractor to pay or provide the wages or supplements in the Prevailing Rate Schedule, or when the Commissioner of Labor believes that unpaid wages or supplements may be due, payments on the Contract shall be withheld from Contractor in a sufficient amount to satisfy the alleged unpaid wages and supplements, including interest and civil penalty, pending a final determination. These amounts will be in addition to the percentages to be retained by Owner pursuant to other provisions of this Contract and other withholdings.

#### 1.9 CONTRACTOR PAYMENTS

- A. Contractor shall pay for all transportation and utility services not later than the

20<sup>th</sup> day of the calendar month following that in which such services are rendered.

- B. Contractor shall pay for all materials and equipment which are delivered to and properly stored at the Site, or in an approved warehouse, to the extent of 90 percent thereof, not later than the 15<sup>th</sup> day following each payment to Contractor and the balance of the cost thereof not later than the 15<sup>th</sup> day following the completion of that part of the Work in or on which such materials and equipment are incorporated or used.
- C. Contractor shall pay each Subcontractor, not later than the 7<sup>th</sup> day following payment to Contractor, the respective amounts allowed Contractor on account of work performed, to the extent of each Subcontractor's interest.

#### 1.10 FINAL PAYMENT

- A. Refer to Section 01 77 19 Closeout Procedures for information on the requirements and procedures for final payment.

#### PART 2 PRODUCTS

NOT USED

#### PART 3 EXECUTION

NOT USED

END OF SECTION

**SECTION 01 31 13  
PROJECT COORDINATION (SINGLE PRIME)**

PART 1 GENERAL

1.1 SUMMARY

- A. This section includes the requirements related to coordination of the Work when a single Contract is awarded.
- B. Related Sections:
  - 1. Section 01 14 17 – Coordination with Owner’s Operations
  - 2. Section 01 32 16 – Construction Progress Schedule
  - 3. Section 01 41 05 – Regulatory Requirements
  - 4. Section 01 45 29 – Testing Laboratory Services

1.2 GENERAL

- A. Refer to Section 01 14 17 Coordination with Owner’s Operations for additional coordination requirements.
- B. Communicate any special procedures required for coordination to Engineer and Owner.
- C. Contractor shall not delegate any administrative or coordination responsibilities to any Subcontractor. Coordinate work of Subcontractors to minimize interference with the progress and performance of the Work.
- D. To ensure the proper execution of subsequent work, Contractor shall measure work already in place, and shall at once report to Engineer any discrepancy between the executed work and the Drawings.

1.3 SCHEDULING

- A. Contractor shall coordinate operations included in various sections of the Contract Documents to assure efficient and orderly installation of each part of the Work according to the Progress Schedule. Refer to Section 01 32 16 Construction Progress Schedule for schedule requirements.
- B. Coordinate delivery and processing of submittals, and installation, relocation, and removal of temporary facilities so as not to impede progress of the Work.
- C. Coordinate the Work operations included under related sections of the Contract Documents that depend on each other for proper installation, connection, and operation, including but not limited to:

1. Scheduling operations in sequence where installation of one part of the Work depends on installation of other components, before or after its own.
2. Coordinate installation of different components to assure maximum accessibility for required maintenance, service, and repair.
3. Provide provisions to accommodate items scheduled for later installation.

## PART 2 PRODUCTS

NOT USED

## PART 3 EXECUTION

### 3.1 INSPECTIONS

- A. Do not obstruct spaces and installations that are required to be clear by applicable Code Requirements.
- B. Coordinate inspections by Engineer of any facilities that will be inaccessible as work progresses. Do not cover any piping, wiring, ducts and other installations until it has been inspected and approved.
- C. Coordinate any necessary inspections by outside agencies that are required for permits or certifications. Refer to Section 01 41 05 Regulatory Requirements for information related to regulatory permits and certifications.

### 3.2 TESTING

- A. Coordinate testing as required in Section 01 45 29 Testing Laboratory Services.
- B. Engineer may require testing of materials, equipment, processes or products as necessary to prove compliance with the Contract Documents or Contractor Submittals. Contractor will coordinate testing with Engineer as necessary.

END OF SECTION

**SECTION 01 31 19.13  
PRE-CONSTRUCTION MEETING**

PART 1 GENERAL

1.1 SUMMARY

A. This section includes the requirements for the meeting between Owner, Engineer and Contractor prior to start of the Work.

B. Related Sections:

1. Section 01 14 17 – Coordination with Owner’s Operations
2. Section 01 14 19 – Use of Site
3. Section 01 26 10 – Contract Modification Procedures
4. Section 01 29 76 – Progress Payment Procedures
5. Section 01 31 19.23 – Progress Meetings
6. Section 01 32 16 – Construction Progress Schedule
7. Section 01 32 33 – Photographic Documentation
8. Section 01 33 10 – Submittal Procedures
9. Section 01 35 23 – Owner Safety Requirements
10. Section 01 35 28 – Contractor’s Health and Safety Plan
11. Section 01 41 05 – Regulatory Requirements
12. Section 01 45 29 – Testing Laboratory Services
13. Section 01 45 33 – Code-Required Special Inspections and Procedures
14. Section 01 51 05 – Temporary Utilities
15. Section 01 52 16 – First Aid Facilities
16. Section 01 52 19 – Sanitary Facilities
17. Section 01 55 10 – Vehicular Access and Parking
18. Section 01 55 33 – Traffic Control
19. Section 01 57 20 – Temporary Bypass Pumping
20. Section 01 65 00 – Product Delivery Requirements
21. Section 01 66 00 – Product Storage and Handling Requirements
22. Section 01 71 23 – Field Engineering
23. Section 01 71 34 – Protection of the Work and Property
24. Section 01 74 10 – Cleaning and Waste Management
25. Section 01 78 39 – Project Record Documents

1.2 SCHEDULING

A. The pre-construction meeting will be held at mutually agreed time between the Notice of Award and Notice to Proceed, or after Notice to Proceed but before on-site work is performed, as applicable. Representatives from Owner, Engineer, and Contractor must be present. Owner, Engineer or Contractor may invite others that are involved in the construction or administration of the Work.

B. Contractor project manager must attend this meeting. Contractor superintendent /

foreman should attend this meeting if they have been assigned prior to the meeting. Subcontractor project managers/superintendents should attend this meeting.

- C. Engineer will conduct the meeting, keep the minutes, and distribute the minutes to all persons in attendance.

### 1.3 MEETING AGENDA

- A. All attendees to meetings must sign in and provide contact information.

- B. Contractor must be prepared to discuss the following agenda items:

- 1. Project Administration

- a. Designated Contacts and Contact Information
- b. Communication
- c. EEO Program Requirements and Goals – Refer to individual sections detailing these programs.
- d. Permit/Regulatory Requirements – Refer to Section 01 41 05 Regulatory Requirements
- e. Start Date and Notice to Proceed
- f. Payment Procedures - Refer to Section 01 29 76 Progress Payment Procedures
- g. Submittals - Refer to Section 01 33 10 Submittal Procedures
- h. Progress Meetings – Refer to Section 01 31 19.23 Progress Meetings
- i. Construction Photographs – Refer to Section 01 32 33 Photographic Documentation
- j. Maintaining Record Documents – Refer to Section 01 78 39 Project Record Documents

- 2. Changes in Work

- a. Requests for Information
- b. Field Orders - Refer to Section 01 71 23 Field Engineering
- c. Change Orders - Refer to Section 01 26 10 Contract Modification Procedures

- 3. Construction Requirements

- a. Engineer's Project Representative
- b. Work Hours
- c. Parking and Staging – Refer to Section 01 14 19 Use of Site and Section 01 55 10 Vehicular Access and Parking
- d. Site Security – Refer to Section 01 71 34 Protection of the Work and

Property

- e. Construction Schedule and Critical Work Sequencing - Refer to Section 01 32 16 Construction Progress Schedule
- f. Product Delivery and Storage – Refer to Section 01 65 00 Product Delivery Requirements and Section 01 66 00 Product Storage and Handling Requirements
- g. Testing - Refer to Section 01 45 29 Testing Laboratory Services and Section 01 45 33 Code-Required Special Inspections and Procedures
- h. Traffic Control – Refer to Section 01 55 33 Traffic Control
- i. Safety – Refer to Section 01 35 23 Owner Safety Requirements and 01 35 28 Contractor's Health and Safety Plan
- j. Site Cleanliness – Refer to Section 01 74 10 Cleaning and Waste Management
- k. Temporary Facilities and Controls – Refer to Sections 01 51 05 Temporary Utilities, 01 52 16 First Aid Facilities, 01 52 19 Sanitary Facilities, 01 57 20 Temporary Bypass Pumping, and 01 58 00 Project Identification.

4. Coordination

- a. Coordination with Owner's Operations - Refer to Section 01 14 17 Coordination with Owner's Operations.

1.4 MEETING MINUTES

- A. Meeting minutes will be written by Engineer, as interpreted and recorded by Engineer.
- B. Meeting minutes will constitute a written record of items discussed. The written record will be binding to all parties. Minutes should be reviewed for accuracy upon receipt.
- C. Meeting minutes shall not be considered a substitute for, or satisfaction of, required submittals, written materials, or notifications specifically called out in other Specifications.
- D. Pre-construction meeting minutes will be reviewed at the first progress meeting. No changes will be made to minutes after review, unless Owner, Engineer and Contractor agree to the change.

PART 2 PRODUCTS

NOT USED

PART 3 EXECUTION

NOT USED

END OF SECTION



**SECTION 01 31 19.23  
PROGRESS MEETINGS**

PART I GENERAL

1.1 SUMMARY

- A. This section includes the requirements for meetings on progress of the Work during Contract Times.
- B. Related Sections:
  - 1. Section 01 14 17 – Coordination with Owner’s Operations
  - 2. Section 01 26 10 – Contract Modification Procedures
  - 3. Section 01 29 76 – Progress Payment Procedures
  - 4. Section 01 32 16 – Construction Progress Schedule
  - 5. Section 01 33 10 – Submittal Procedures
  - 6. Section 01 41 05 – Regulatory Requirements
  - 7. Section 01 45 29 – Testing Laboratory Services
  - 8. Section 01 45 33 – Code-Required Special Inspections and Procedures
  - 9. Section 01 71 23 – Field Engineering
  - 10. Section 01 73 24 – Connections to Existing Facilities

1.2 SCHEDULING

- A. Progress meetings will be conducted approximately once per Work Order, or at some other frequency as determined by Engineer. These meetings shall be attended by Owner, Engineer, Contractor’s representative. Owner, Engineer or Contractor may invite others that are involved in the construction or administration of the Work.
- B. Engineer will conduct the meeting, keep the minutes, and distribute the minutes to all persons in attendance.

1.3 MEETING AGENDA

- A. All attendees to meetings must sign in and provide contact information.
- B. Contractor must be prepared to discuss the following agenda items:
  - I. Construction Progress
    - a. Work Completed
    - b. Testing Results - Refer to Section 01 45 29 Testing Laboratory Services and Section 01 45 33 Code-Required Special Inspections and Procedures
    - c. Schedule Updates - Refer to Section 01 32 16 Construction Progress Schedule

- d. Critical Work Sequencing
- e. Upcoming Work

2. Changes in Work

- a. Requests for Information
- b. Field Orders - Refer to Section 01 71 23 Field Engineering
- c. Change Orders - Refer to Section 01 26 10 Contract Modification Procedures

3. Project Administration

- a. Submittals - Refer to Section 01 33 10 Submittal Procedures
- b. EEO Program Status – Refer to individual section describing programs.
- c. Permit/Regulatory Requirements - Refer to Section 01 41 05 Regulatory Requirements
- d. Payment Requests - Refer to Section 01 29 76 Progress Payment Procedures

4. Coordination

- a. Coordination with Owner's Operations - Refer to Section 01 14 17 Coordination with Owner's Operations
- b. Strategies for Connections to Existing Facilities - Refer to Section 01 73 24 Connections to Existing Facilities

5. Deficiencies in Work

1.4 MEETING MINUTES

- A. Meeting minutes will be written by Engineer, as interpreted and recorded by Engineer.
- B. Meeting minutes will constitute a written record of items discussed. The written record will be binding to all parties. Minutes should be reviewed for accuracy upon receipt.
- C. Meeting minutes shall not be considered a substitute for, or satisfaction of, required submittals, written materials, correspondence, or notifications specifically required in other Specifications.
- D. Meeting minutes will be reviewed at the next meeting. No changes will be made to minutes after review, unless Owner, Engineer and Contractor agree to change.

PART 2 PRODUCTS

NOT USED

PART 3 EXECUTION

NOT USED

END OF SECTION

**SECTION 01 32 16**  
**CONSTRUCTION PROGRESS SCHEDULE**

PART 1 GENERAL

1.1 SUMMARY

- A. This section includes the requirements for the Progress Schedule including submittals, format, monthly review, updates, revisions and request for time extension.
- B. Related Sections:
  - 1. Section 01 14 17 – Coordination with Owner’s Operations
  - 2. Section 01 26 10 – Contract Modification Procedures
  - 3. Section 01 31 13 – Project Coordination Single Prime
  - 4. Section 01 31 19.23 – Progress Meetings
  - 5. Section 01 33 10 – Submittal Procedures

1.2 GENERAL

- A. Progress Schedule shall represent a practical plan to complete the Work within Contract Times and shall convey Contractor’s intent in the manner of progress of the Work.
- B. Scheduling and means and methods of construction are the responsibility of Contractor. Contractor shall involve and coordinate all Subcontractors and Suppliers in the development and updating of the Progress Schedule.
- C. Contractor will not be penalized for failure to meet finish dates for individual tasks indicated in the Progress Schedule as long as Contract Times are met, unless otherwise indicated in the Contract Documents.
- D. Refer to Section 01 14 17 Coordination with Owner’s Operations for limitations and information on operations that effect scheduling.
- E. When the Project involves only one Contract, refer to Section 01 31 13 Project Coordination Single Prime for information on scheduling.
- F. Each Contractor shall be responsible for the proper coordination of all work under their respective Contract so as to maintain the Progress Schedule as accepted. Should any Contractor fail to adhere to any critical task of the accepted schedule, Contractor shall promptly adopt such additional means or methods of construction, including overtime, as may be required to complete the Work in accordance with the schedule, all at no additional cost to Owner.

### 1.3 SUBMITTALS

- A. Submittal of the Progress Schedule shall conform with the requirements of Section 01 33 10 Submittal Procedures.
- B. Schedules shall be submitted in time-scaled bar-chart (Gantt) format with logic lines shown. Format shall be as indicated in Article 1.4.
- C. Within 5 days after the date of Notice to Proceed, Contractor shall submit to Engineer for review one electronic copy of his proposed Progress Schedule.
  - 1. Progress Schedule shall show in detail the proposed sequence of the Work in order to complete the Project within Contract Times.
  - 2. If so required by Engineer, the schedule shall be revised.
- D. In submittal of Progress Schedule, Contractor represents that it meets the requirements of the Work Order and that the Work will be executed in the sequence and durations indicated therein.

### 1.4 FORMAT

- A. Progress Schedule shall be electronically produced in the Critical Path Method (CPM) format, unless another format is approved by Engineer.
- B. Progress Schedule shall indicate the following:
  - 1. Contract tasks and baseline schedules.
  - 2. Critical path operations.
  - 3. Sequence of tasks.
  - 4. Task start and finish dates.
  - 5. Task percent complete with progress bars.
  - 6. Milestone completion dates.
  - 7. Submittals and submittal reviews.
  - 8. Inspection and acceptance dates.
  - 9. Acquisition of permits, if needed.
  - 10. Product lead time if over 30 days.
  - 11. Work performed by other Contractors or Agencies that impact the Work.
- C. Scheduled tasks shall include sufficient detail as to identify work to be accomplished. Tasks should conform with bid item breakdown.
- D. Work to be performed by Subcontractors shall be clearly identified.

### 1.5 UPDATES

- A. The Progress Schedule shall be updated if required.
- B. Impacts of Progress Schedule updates on Owner and other Contracts shall be considered in the update.
- C. Updates to the Progress Schedule shall be submitted electronically, in the required format, to Engineer. Updates shall be submitted prior to a progress meeting to assist in review at the meeting.
- D. The Progress Schedule shall be discussed at all progress meetings. Refer to Section 01 31 19.23 Progress Meetings for frequency of and agenda for progress meetings.

#### 1.6 REVISIONS

- A. In the event Contractor does not adhere to their Progress Schedule and risks delays to other Contracts or Owner, Engineer may require revisions to the Progress Schedule as deemed necessary to reduce or eliminate such delays.
- B. Failure to progress the Work in accordance with the Progress Schedule submitted and accepted by Engineer may, at the discretion of Engineer, be construed as a failure to comply with the terms of the Contract.
- C. Revisions to critical path items in the Progress Schedule, or to items that impact Owner or other Contractors, may only be made with the knowledge and consent of Engineer.
- D. Engineer will require revisions to the Progress Schedule whenever any task is delayed or extends beyond the finish date to the extent that it is impacting other work. Engineer will determine when those revisions are necessary.
- E. Contractor may request permission to revise any part of the Progress Schedule. Requests will be made in writing to Engineer, who will consider the impact of such a change on the Project. Engineer will respond in writing with an approval or explanation as to why the requested change cannot be made.
- F. Revised Progress Schedules will be submitted to Engineer for approval. Engineer will distribute approved revisions.

#### 1.7 REQUEST FOR TIME EXTENSION

- A. Continued maintenance of the Progress Schedule is the best way to estimate completion times and determine if Contract Times will need to be extended.
- B. A request for time extension for individual Work Orders does not require a

change to the Contract, unless otherwise stated in the Contract Documents.

- C. A request for time extension that changes Contract Times must be submitted in accordance with GC Article 11. Refer to Section 01 26 10 Contract Modification Procedures for information on changes to the Contract, including an extension of Contract Times.

PART 2 PRODUCTS

NOT USED

PART 3 EXECUTION

NOT USED

END OF SECTION

**SECTION 01 33 10  
SUBMITTAL PROCEDURES**

PART 1 GENERAL

1.1 SUMMARY

- A. This section includes administrative and procedural requirements for Submittals.
- B. Related Sections:
  - 1. Section 01 25 13 – Product Substitution Procedures
  - 2. Section 01 77 19 – Closeout Requirements

1.2 DEFINITIONS

- A. Performance Affidavit – A legal document stating that the performance of submitted equipment, apparatus, process or system meets the performance requirements of the Contract Documents.
- B. Warranty – A legal document certifying that if the equipment, apparatus, process or system fails in operation or performance for a given term, the manufacturer will be responsible for making all necessary repairs or replacements to meet operational or performance requirements.

1.3 SUBMITTALS – GENERAL

- A. Unless otherwise agreed upon by all parties, Submittals shall be submitted via e-mail in electronic PDF format. Submittals shall be made to the listed contacts for Owner and Engineer for the Project.
- B. Sequentially number each Submittal. Resubmittals are to have original number with an alphabetic suffix.
- C. Identify Project, Contractor, Subcontractor or Supplier, pertinent Drawings sheet number, pertinent detail number(s) from the Drawings, and Specifications section number, on each Submittal as appropriate.
- D. Schedule the Submittals to expedite the Project. Coordinate submission of related items.
- E. Owner is permitted to inspect and test materials, or require inspection or testing of materials, submitted for approval. Engineer is the sole judge if it is necessary that any material or equipment be inspected at the place of manufacture.

1.4 SAMPLES



- A. Upon written notice from Engineer, or where specified in the Contract Documents, Contractor shall submit to Engineer, for review, samples of materials proposed for use. Samples shall be in duplicate, of sufficient size, number or amount to show the quality, type, range of color, finish, and texture of the material intended to be furnished under this Contract.
  - 1. Each sample shall be labeled bearing the name and quality of the materials, Contractor's name, date and name of the Project.
  - 2. A letter from Contractor requesting review, shall accompany all samples.
  - 3. Samples shall be submitted in due time so as to permit proper consideration without delaying Contractor's operation.

1.5 MANUFACTURER PERFORMANCE AFFIDAVITS

- A. When specified, Contractor shall provide a Performance Affidavit for the product or equipment listed.
- B. In the Performance Affidavit, each manufacturer shall certify to Contractor and Owner, jointly, that the Contract Documents have been examined and that the equipment, apparatus, process or system offered will meet in every way the performance requirements set forth in the Contract Documents. Equipment design, manufacturing and assembly specifications are an integral part of the performance requirements.
- C. Shop Drawings will not be reviewed prior to the receipt by Engineer of an acceptable Performance Affidavit.
- D. The Performance Affidavit must be signed by an officer (vice president or higher) of the basic corporation, partnership, or company manufacturing the equipment, and witnessed by a notary public.
- E. The Performance Affidavit shall be in the following format:

Addressed to: (Contractor) and (Owner)

Reference: (Contract Name)

Text: (manufacturer's name) has examined the Contract Documents and verifies that the (product) meets in every way the performance requirements and design specifications set forth in Section (s) \_\_\_\_\_ of the Contract Documents.

Signature: (Corporate officers - vice president or higher)

Notary: (Signature(s) must be notarized)

## 1.6 MANUFACTURER WARRANTY

- A. When specified, Contractor shall provide a Warranty for the product or equipment listed. The terms of the Warranty shall be included in the Submittal.
- B. The Warranty shall be provided for the length of time (term) specified in the Contract Documents and that term shall be clearly stated in the Warranty. If no term is specified, warranty shall be the manufacturer's standard, but not less than two (2) years.
- C. Any restrictions to the Warranty shall be clearly stated.
- D. Any conditions that would void the Warranty shall be clearly stated.
- E. The entity to be contacted to perform Warranty work shall be identified with complete contact information including address, telephone number for service, and e-mail address.

## 1.7 SUBMITTAL DEVIATIONS, SUBSTITUTIONS, AND "OR EQUAL"

- A. Identify deviations from the Contract Documents, where the Submittal meets Contract requirements but cannot be provided exactly as specified:
  - 1. Product or system limitations which may impact the performance of any part of the Work must be clearly stated in the cover documents.
  - 2. If the Submittal deviates from the requirements of the Specifications in any way, it shall be clearly marked in the Submittal and stated in the cover documents with justification, for evaluation by Engineer.
  - 3. Engineer shall evaluate all deviations and may determine that the Submittal should be classified as a substitution. Submittal must then meet the requirements in Section 01 25 13 Product Substitution Procedures.
- B. If the Shop Drawings contains any departures from the Contract requirements, the Submittal is a substitution and must meet the requirements of Section 01 25 13 Product Substitution Procedures. Submittals identified as substitutions are to be submitted in the same format as other Submittals.
- C. Where a Shop Drawings is submitted as an "or equal" the burden of proof that the Submittal is equal is on Contractor. In addition to other materials, Contractor shall furnish a listing of existing installations that the proposed equal may be reviewed, along with contact people at the existing installation.

## 1.8 SHOP DRAWINGS SUBMITTAL REQUIREMENTS

- A. Contractor shall submit for review, by Engineer, Shop Drawings for all fabricated work, manufactured items, equipment and material required to be furnished in the Contract and as required by the Specifications.
- B. Apply Contractor's stamp, signed or initialed certifying that review, verification of products required, field dimensions, adjacent construction work, and coordination of information, is in accordance with the requirements of the Project and Contract Documents. Stamp shall show the following information:

- 1. Shop Submittal Number \_\_\_\_\_
- 2. Deviations: None \_\_\_\_\_ As Listed \_\_\_\_\_
- 3. Reference Specification Number \_\_\_\_\_
- 4. Reference Drawing Number \_\_\_\_\_
- 5. Space Requirements: As Designed \_\_\_\_\_ As Listed \_\_\_\_\_

6. Representation is made to Owner and Engineer that Contractor has determined and verified all field measurements and quantities, field construction criteria, materials, catalog numbers and similar data, that they have reviewed and coordinated the information in each Shop Drawings with the requirements of the Work and Contract Documents, and hereby approves this submittal.

Contractor \_\_\_\_\_

Signature \_\_\_\_\_

Date \_\_\_\_\_

1.9 SHOP DRAWINGS SUBMITTAL TECHNICAL CONTENT

- A. Shop Drawings Submittals shall be complete and accurate and shall include the following to indicate item-by-item compliance with the Contract Documents:
  - 1. Verbal descriptions.
  - 2. Descriptive data.
  - 3. Performance characteristics.
  - 4. Material specifications.
  - 5. Drawings.

6. Piping diagrams.
  7. Wiring schematics.
  8. Catalog cuts.
  9. Manufacturer's specifications.
  10. Spare parts list.
- B. Submittal shall be clearly marked to allow identification of the specific products used. Catalog cuts showing information for more than one item on the page shall clearly indicate what items Contractor will be supplying under this Contract by clearly highlighting by applying unique color, arrows, or other identifying marks.
  - C. Equipment manufacturers supplying equipment for the project shall examine the Drawings and Specifications pertaining to their particular equipment in order to be fully acquainted with the operating conditions to which the equipment will be subjected.
  - D. Shop Drawings for each major component of a system or subsystem, and its appurtenances, shall be submitted under separate cover, but all Shop Drawings for equipment which is part of the same system or subsystem shall be submitted in the form of a package.
    1. If requested by Engineer, Contractor shall supplement the Submittal(s) by such data, as required, to demonstrate that the sizes, capacities, characteristics and/or performances of each component of a system or subsystem, are consistent (compatible) with each other and with the provisions of the Specifications, for said system or subsystem.
  - E. The foregoing shall not relieve Contractor of any responsibilities under any Warranty or Performance Affidavit specified herein.
  - F. Where required, professional design documents shall be submitted with any required professional signature and seal.

#### 1.10 SHOP DRAWINGS REVIEW

- A. Acceptance or approval of a Shop Drawings shall not relieve Contractor of any responsibilities under the Contract.
- B. Any fabrication, erection, setting or other work done in advance of the receipt of Shop Drawings returned by Engineer and noted as "REVIEWED" or "REVIEWED AS NOTED," shall be entirely at Contractor's risk.

- C. When a Shop Drawings Submittal is satisfactory to Engineer, the Submittal will be stamped "REVIEWED" or "REVISED AS NOTED", be dated, and the Shop Drawings will be returned to Contractor by the same manner it was received.
- D. When a Shop Drawings Submittal is returned to Contractor "REVISED AS NOTED", Contractor shall acknowledge in writing to Engineer that they will provide, as required, all items noted and further that these notations have been properly provided to Suppliers, Subcontractors, and manufacturers associated with the product's Shop Drawings to assure compliance with Engineer's review.
- E. When a Shop Drawings Submittal is deemed to be unsatisfactory to Engineer, the Submittal will be stamped "REVISE AND RESUBMIT" and Engineer will return the deficient Shop Drawings to Contractor by the same manner it was received, with the necessary corrections and changes indicated. Contractor shall make such corrections and changes as indicated and resubmit revised Shop Drawings for further review by Engineer. Contractor shall revise and resubmit the Shop Drawings as required by Engineer, until acceptance thereof is obtained.
- F. Should a Shop Drawings be unacceptable to Engineer, the Submittal will be stamped "NOT ACCEPTED" and Engineer will return the deficient Shop Drawings to Contractor in the same manner it was received. It will be Contractor's responsibility to resubmit a Shop Drawings that complies with the Contract Documents and that is acceptable to Engineer.

#### 1.11 POST-CONSTRUCTION SUBMITTALS

- A. All post-construction Submittals shall include a cover letter indicating the date of completion or Substantial Completion of the project, name of the Project, and identify Contractor, Engineer and Owner.
- B. All post-construction documents shall be submitted in PDF electronic format and two (2) hard copies shall be provided, unless otherwise indicated in the Contract Documents.
  - 1. Electronic copies of greater than 15 MB shall be submitted on transferrable media and not transmitted through e-mail, unless otherwise indicated in the Contract Documents or agreed upon by all parties.
  - 2. Hard copies shall be submitted to Owner, unless otherwise indicated in the Contract Documents or agreed upon by all parties.
- C. Upon completion of the Work, Contractor shall submit a form of guarantee certifying all of the Work performed under their Contract, for a correction period of a minimum one-year term, unless otherwise specified in the Contract

Documents.

- D. Operation and Maintenance (O&M) Manuals and any other post-construction Submittals required by the Contract Documents shall be submitted upon completion of the Work.
  - 1. Refer to Section 01 77 19 Closeout Requirements for detailed information for documents required to close out the Project.
- E. Where a manual is required, a table of contents shall be included and all sections shall be tabbed in the hard copy and separated by colored pages in the electronic copy.

PART 2 PRODUCTS

NOT USED

PART 3 EXECUTION

NOT USED

END OF SECTION

**SECTION 01 35 23  
OWNER SAFETY REQUIREMENTS**

PART 1 GENERAL

1.1 SUMMARY

- A. This section includes minimum, general safety requirements instituted by Owner or general recommendations for safety at Owner's facilities.
- B. Where Owner's requirements conflict with OSHA Standards or Federal, State and Local health and safety requirements, the more stringent shall apply.
- C. Related Sections:
  - 1. Section 01 35 28 – Contractor's Health and Safety Plan

1.2 GENERAL

- A. No information listed shall relieve Contractor of their obligation to comply with requirements instituted by the Occupational Safety and Health Administration (OSHA) or any other Federal, State or Local health and safety regulations and requirements that apply to the Project.
- B. No information listed shall relieve Contractor of their sole responsibility for health and safety of all workers under their control. Contractor shall incorporate requirements from this section, as appropriate, into the Contractor's Health and Safety Plan, prepared and submitted in accordance with Section 01 35 28 Contractor's Health and Safety Plan.
- C. All work areas should be reviewed by Contractor to determine safety requirements for all workers under the control of Contractor, regardless of designation or lack of designation by Owner.

1.3 Personal Protective Equipment (PPE)

- A. Owner requires the use of the following PPE when working in process areas of the facility:
  - 1. Safety shoes
  - 2. Safety helmet/hard hat
- B. Owner recommends the use of the following PPE:
  - 1. Eye protection in process areas or when coming into contact with wastewater or wastewater solids.

2. Ear protection in areas with greater than 70dB of noise.
  3. Masks or face shields as appropriate for the work being performed or when coming into contact with wastewater or wastewater solids.
  4. Gloves as appropriate for the work being performed or in the solids handling or chemical storage areas of facilities. Latex gloves or similar level protection is recommended when coming into contact with wastewater or wastewater solids.
  5. Waterproof or chemical resistant material body protection, such as rubber, plastic or Tyvek suits, boots, gloves, or waders, when a body part must be submerged in wastewater or wastewater solids.
- C. All PPE must be supplied by Contractor and comply with appropriate regulations.

#### 1.4 EVACUATION PLAN

- A. Where applicable, Contractor shall familiarize themselves with the posted evacuation plan at the facility at which the Work is located. Contractor shall notify Engineer if such a plan cannot be located or if the Work prevents Contractor from carrying out the plan as designated.
- B. Where applicable, Contractor shall identify the nearest exit from the facility in the event of an emergency which requires evacuation.
- C. Contractor shall notify Engineer or Owner whenever present at a facility in case of emergency.

#### 1.5 EMERGENCY SERVICES

- A. Contractor shall identify emergency services in close proximity to the Site and how to request services. These services include, without limitation, police, fire and medical. Contractor shall notify Engineer or Owner if services cannot be identified and information will be provided.
- B. Contractor shall retain the address of the work site, as identified in the Contract Documents, to appropriately direct services in the event of an emergency.

### PART 2 PRODUCTS

NOT USED

### PART 3 EXECUTION

NOT USED

END OF SECTION



**SECTION 01 35 26.23**  
**CONFINED SPACE ENTRY PLAN**

PART 1 GENERAL

1.1 SUMMARY

- A. This section includes administrative requirements for Contractor's Confined Space Entry Plan.
- B. Related Sections:
  - 1. Section 01 33 10 – Submittal Procedures
  - 2. Section 01 35 28 – Contractor's Health and Safety Plan

1.2 DEFINITIONS

- A. Contractor's Health and Safety Plan – A plan written and administered by Contractor to identify and explain the policies and procedures of Contractor with regard to the health and safety of those under their control when working at the Site or on components of the Project.
- B. Confined Space Entry Plan – A plan, that may be a component of the Contractor's Health and Safety Plan, that addresses requirements for entry into a confined space, as defined in applicable regulations.
- C. Safety Officer –The person(s) identified in Contractor's Health and Safety Plan as responsible for ensuring that all workers under the control of Contractor understand, are trained in, and adhere to the requirements in that Contractor's Health and Safety Plan. This officer must be an employee of, company contracted by, or otherwise under the control of Contractor.

1.3 CONFINED SPACE – GENERAL

- A. The Occupational Health and Safety Administration (OSHA) defines different types of confined spaces. Contractor must refer to the most recent regulations when determining if an area is a confined space.
- B. Contractor shall comply fully with the rules and regulations as stated in OSHA 29 CFR 1910, Subpart AA of 29 CFR 1926 and any other applicable regulation.
- C. Owner may identify areas that could be considered confined spaces. Contractor shall evaluate all areas involved in the Work and independently determine what precautions are necessary for workers under their control.
- D. When the Project contains more than one Contract, each Contractor shall be

required to coordinate confined space entry operations with the other Contractors when workers under the control of more than one Contractor are working simultaneously within a confined space.

- E. Owner's operations generally deal with industrial, municipal and residential wastewater. Wastewater is known to contain viruses, compounds, and chemicals. Such materials may become concentrated in a confined space.

#### 1.4 CONFINED SPACE ENTRY PLAN

- A. Contractor shall complete the Confined Space Program Certification in the Proposal section when submitting their bid, certifying that Contractor has established a Confined Space Program which conforms to OSHA 29 CFR 1910 and OSHA Subpart AA of 29 CFR 1926 and that full implementation of Contractor's Confined Space Entry Plan is a requirement of this Contract.
- B. Review or acceptance of the Confined Space Entry Plan shall not relieve Contractor of any responsibilities related to the health and safety of the workers under their control.
- C. Contractor shall submit a Confined Space Entry Plan, either as part of the Contractor's Health and Safety Plan or as an independent document, to demonstrate that Contractor has policies and procedures related to confined spaces and to identify those policies and procedures.
  - 1. Requirements for the Contractor's Health and Safety Plan are contained in Section 01 35 28 Contractor's Health and Safety Plan.
  - 2. Requirements for submitting documents is contained in Section 01 33 10 Submittal Procedures.
- D. Engineer, in reviewing or accepting a Contractor's Confined Space Entry Plan, is acknowledging the policies and procedures of Contractor but is not determining the compliance of such a plan with any regulatory requirements. Contractor is responsible for ensuring compliance with regulations.
- E. Engineer, in reviewing or accepting a Contractor's Confined Space Entry Plan, is not approving the content of the Plan. Engineer may request additional information if the submitted plan does not appear to contain policies and procedures sufficient to protect health and safety.
- F. If Engineer or Owner should question a method utilized in the Contractor's Confined Space Entry Plan, Contractor will be required to obtain a written response from OSHA which will determine if the procedure does or does not satisfy the requirements of OSHA 29 CFR 1910 and Subpart AA of 29 CFR 1926.

Failure by Contractor to undertake the necessary steps to produce a written response from OSHA may delay the processing of the monthly payment estimate(s).

G. Contractor and their Safety Officer shall be on-site to ensure that the Work is carried out in accordance with their Confined Space Entry Plan and OSHA, or any other applicable regulations.

H. Contractor shall inform Engineer and Owner of any changes to the submitted Confined Space Entry Plan.

PART 2 PRODUCTS

NOT USED

PART 3 EXECUTION

NOT USED

END OF SECTION

**SECTION 01 35 28**  
**CONTRACTOR'S HEALTH AND SAFETY PLAN**

PART 1 GENERAL

1.1 SUMMARY

- A. This section includes administrative requirements for Contractor's plan to comply with health and safety regulations instituted by the Occupational Safety and Health Administration (OSHA) and any other Federal, State or Local health and safety regulations and requirements that apply to the Project.
- B. Contractor is solely responsible for all site safety. Contractor's equipment and methods of operation shall be in full compliance with OSHA Standards and satisfy all Federal, State and Local health and safety regulations and requirements, regardless if they are explicitly stated in the Contractor's Health and Safety Plan. Contractor will be solely responsible for his safety program and the coordination of such with all persons and companies under his control.
- C. Related Sections:
  - 1. Section 01 33 10 – Submittal Procedures
  - 2. Section 01 35 26-23 – Confined Space Entry Plan
  - 3. Section 01 52 16 – First Aid Facilities

1.2 DEFINITIONS

- A. Contractor's Health and Safety Plan – A plan written and administered by Contractor to identify and explain the policies and procedures of Contractor with regard to the health and safety of those under their control when working at the Site or on components of the Project.
- B. Confined Space Entry Plan – A plan, that may be a component of the Contractor's Health and Safety Plan, that addresses requirements for entry into a confined space, as defined in applicable regulations.
- C. Safety Officer –The person(s) identified in Contractor's Health and Safety Plan as responsible for ensuring that all workers under the control of Contractor understand, are trained in, and adhere to the requirements in that Contractor's Health and Safety Plan. This officer must be an employee of, company contracted by, or otherwise under the control of Contractor.

1.3 HEALTH AND SAFETY – GENERAL

- A. OSHA administers and enforces regulations and requirements related to construction health and safety, generally included in 29 CFR 1926. Contractor

must refer to the most recent regulations when creating a Contractor's Health and Safety Plan.

- B. Owner may identify areas of the Site or components of the Work that are of particular concern. Contractor shall evaluate all areas and components involved in the Work and independently determine what precautions are necessary for workers under their control.
- C. When the Project contains more than one Contract, each Contractor shall be required to coordinate health and safety requirements with the other Contractors when workers under the control of more than one Contractor are working simultaneously within an area or on a Site.
- D. Owner's operations generally deal with industrial, municipal and residential wastewater. Wastewater is known to contain viruses, compounds, and chemicals. Contact with wastewater should be considered when creating the Contractor's Health and Safety Plan.
- E. First aid facilities must be provided at the Site for workers that are injured in connection with the Work, in accordance with Section 01 52 16 First Aid Facilities.

#### 1.4 PLAN REQUIREMENTS

- A. Contractor's Health and Safety Plan shall be specific to the Project and include identified hazards and precautions for the Site.
- B. Contractor shall submit a Confined Space Entry Plan, either as part of the Contractor's Health and Safety Plan or as an independent document. Requirements for the Confined Space Entry Plan are contained in Section 01 35 26-23 Confined Space Entry Plan.
- C. References to written OSHA regulations shall be included.
- D. Requirements for submitting documents is contained in Section 01 33 10 Submittal Procedures.
- E. Contractor's Health and Safety Plan must be submitted and accepted before any work can take place on the Site.

#### 1.5 PLAN REVIEW

- A. Engineer, in reviewing or accepting a Contractor's Health and Safety Plan, is acknowledging the policies and procedures of Contractor but is not determining the compliance of such a plan with any regulatory requirements. Contractor is

responsible for ensuring compliance with regulations.

- B. Engineer, in reviewing or accepting a Contractor's Health and Safety Plan, is not approving the content of the Plan. Engineer may request additional information if the submitted plan does not appear to contain policies and procedures sufficient to protect health and safety.

#### 1.6 PLAN ADMINISTRATION

- A. All persons under control of Contractor, including supervisory and all levels and types of workers, shall be trained in the submitted Contractor's Health and Safety Plan.
- B. All safety equipment such as harnesses, protective clothing, respiratory, air monitoring, ventilating, and similar apparatus for activities associated with construction or testing of the Work shall be provided by Contractor.
- C. If Engineer or Owner should question a method utilized in the Contractor's Health and Safety Plan, Contractor will be required to obtain a written response from OSHA which will determine if the procedure does or does not satisfy the requirements of OSHA 29 CFR Part 1926. Failure by Contractor to undertake the necessary steps to produce a written response from OSHA may delay the processing of the monthly payment estimate(s).
- D. Contractor shall inform Engineer and Owner of any changes to the submitted Contractor's Health and Safety Plan.

### PART 2 PRODUCTS

NOT USED

### PART 3 EXECUTION

#### 3.1 REPORTING

- A. Contractor shall promptly report, in writing to Engineer, all accidents which caused death, personal injury or property damage, whatsoever arising out of or in connection with the performance of the Work, whether on or adjacent to the Site.
  - 1. Contractor must give full details and statements of witnesses.
  - 2. If death or serious injuries or serious damages are caused, the accident shall be reported immediately by telephone or message to both Engineer and Owner.
  - 3. If any claim is made by anyone against Contractor or their Subcontractor,

Contractor shall promptly report the circumstances in writing to Engineer, giving full details of the claim, including the exact wording of the claim.

### 3.2 PLAN COMPLIANCE

- A. Contractor shall provide a safe environment for all persons entering the Site or completing the Work.
- B. Precaution shall be exercised at all times for the protection of persons (including employees) and property, and hazardous conditions shall be guarded against or eliminated.
- C. Contractor shall notify other Contractors, Engineer and Owner of any requirements that should be observed while the Work is in progress.
- D. The Safety Officer shall visit the Site to ensure all persons under the control of Contractor are following the Contractor's Health and Safety Plan and all applicable OSHA regulations.
- E. Any notification by Engineer or Owner requesting clarification of Contractor activities or actions of persons under Contractor's control, related to the Contractor's Health and Safety Plan, shall be addressed by the Safety Officer or his on-site representative.
  - 1. Notifications by Engineer or Owner do not relieve Contractor from complete responsibility for Contractor and Site health and safety.
  - 2. Notifications by Engineer or Owner do not determine compliance with the Contractor's Health and Safety Plan or any regulations but request clarification of Contractor's interpretation of the plan.

END OF SECTION

**SECTION 01 35 43-13**  
**ENVIRONMENTAL PROCEDURES FOR HAZARDOUS MATERIALS**

PART 1 GENERAL

1.1 SUMMARY

- A. This section includes environmental procedures for hazardous materials that are used in the course of the Work.
- B. This section does not include hazardous materials encountered on the Site.
- C. Related Sections:
  - 1. Section 01 35 28 – Contractor’s Health and Safety Plan
  - 2. Section 01 52 16 – First Aid Facilities

1.2 DEFINITIONS

- A. Hazardous Material – Any material containing hazardous properties or hazardous components as defined by the Occupational Safety and Health Administration (OSHA) or other regulatory agency.
- B. Hazard Communication Standard (HCS) – The standard, issued by OSHA, that provides guidance on classifying chemicals and communicating hazards.
- C. Safety Data Sheet (SDS) –A standard format of information from a chemical manufacturer, distributor or importer that explains the properties of each chemical; physical, health and environmental hazards; protective measures; and safety precautions for handling, storage and transportation, as required in the HCS.

1.3 ENVIRONMENTAL PROCEDURES – GENERAL

- A. OSHA administers and enforces regulations and requirements related to the hazard communications, generally included in 29 CFR 1910.1200. Contractor must refer to the most recent regulations when determining the applicability of the regulations to the materials at the Site.
- B. Owner may identify components of the Work that would be considered Hazardous Materials. Contractor shall evaluate all components involved in the Work and independently determine what precautions and communications are necessary.
- C. Contractor shall make all hazard communication information available to other Contractors, Engineer and Owner at all times.



- D. Owner's operations generally deal with industrial, municipal and residential wastewater. Wastewater is known to contain viruses, compounds, and chemicals but is not considered a hazardous material.
- E. First aid facilities provided for workers must include, to the extent possible, materials to stabilize injuries associated with hazardous materials. Refer to Section 01 52 16 First Aid Facilities.
- F. Known hazards and plans to mitigate hazards should be identified in the Contractor's Health and Safety Plan. Refer to Section 01 35 28 Contractor's Health and Safety Plan.

#### 1.4 HCS REQUIREMENTS

- A. Contractor shall determine the Hazardous Materials involved in the Work and determine the communication requirements.
- B. SDSs shall be kept and maintained according to regulation.
- C. Workers must be trained on the handling and use of any Hazardous Materials involved in their work.

### PART 2 PRODUCTS

NOT USED

### PART 3 EXECUTION

#### 3.1 HCS MAINTENANCE

- A. Contractor shall maintain the inventory of SDSs and any other hazard information throughout construction. This shall be available at all times.
- B. No materials shall be brought onto the Site without the accompanying SDS.
- C. Contractor shall notify other Contractors, Engineer and Owner of any Hazardous Materials in use throughout the progress of the Work.
- D. Contractor is responsible to train and educate all persons under their control as to any Hazardous Materials and any hazards present as a result.
- E. Contractor shall supply the necessary equipment, materials, and personal protective equipment throughout construction to mitigate hazards.

END OF SECTION

**SECTION 01 91 13**  
**GENERAL COMMISSIONING REQUIREMENTS**

PART 1 GENERAL

1.1 SUMMARY

- A. This section includes requirements for commissioning the Work.
- B. Related Sections:
  - 1. Section 01 33 10 – Submittal Procedures

1.2 GENERAL

- A. Commissioning is the process of ensuring that all components and systems included in the Work perform interactively as intended by, and meet all the requirements of, the Contract Documents.

PART 2 PRODUCTS

NOT USED

PART 3 EXECUTION

3.1 COLLECTIONS SYSTEMS COMMISSIONING PLAN

- A. Commissioning includes testing and acceptance in accordance with Section 02375 and other requirements of the technical specifications.
- B. Contractor shall notify Engineer and Owner that new sewerlines or systems are ready to be placed into operation or final connections (tie-ins) made. Engineer shall coordinate, within 3 days of notification, with Contractor and Owner to determine a schedule for final connections.
- C. If any deficiencies are found through testing, inspections, or visual observance, items of non-compliance with the Contract Documents shall be documented and deficiencies shall be resolved, with resolutions documented.
- D. If any deficiency is unable to be resolved during any phase of commissioning, Engineer will determine the impact on commissioning and whether or not the phase was successful. Regardless of the determination, all deficiencies must be immediately.

END OF SECTION

utilities installed or encountered during the course of work.

4. Change in location, elevation, dimensions, modifications, additions to structures.
5. Changes in mechanical trades components (electrical, heating, ventilating, plumbing, instrumentation) and measured location of all utilities or trade components concealed from view with references to visible and accessible feature of the structure.
6. Final location and manufacturer information of all equipment.
7. Change in materials, such as pipe material and equipment.
8. Final wiring diagrams of all control panels, electrical panels and equipment panels including conduit sizes and wiring.
9. Final wiring diagrams of all instrumentation including conduit sizes and wiring.
10. Changes in all site improvements including topographical contours of finished grades and paved surfaces, final elevations and locations of all chambers and utilities visible in project area, paving limits, etc.
11. All other items deemed important to provide on record drawings.

#### 1.4 FORMAT

- A. Electronic record information shall be AutoCAD format or PDF files readable by the most recent version of Adobe software. Any scanned documents shall be readable while minimizing file size.
- B. Paper copies of the record documents shall be supplied in one package. A listing of all record documents shall be provided with the documents.
- C. Owner will use Contractor record documents to create the documents for the Project. Final payment cannot occur until Contractor record documents have been reviewed.

PART 2 PRODUCTS  
NOT USED

PART 3 EXECUTION  
NOT USED

END OF SECTION

**SECTION 01 78 39**  
**PROJECT RECORD DOCUMENTS**

PART 1 GENERAL

1.1 SUMMARY

- A. This section includes administrative and procedural requirements for preparing and supplying record documents of the Work done by Contractor.
- B. Related Sections:
  - 1. Section 01 33 10 – Submittal Procedures
  - 2. Section 01 77 19 – Closeout Requirements

1.2 GENERAL

- A. Contractor shall maintain on site one set of Work Order drawings for the purpose of documenting “record” conditions. Store record drawings separate from documents used for construction. Record information concurrent with construction progress and make available for periodic examination by the Engineer. Ensure that entries are complete and accurate, enabling future reference by the Owner.
- B. It shall be the responsibility of Contractor to legibly mark in red all field changes and conditions as they may occur. A complete file of record field sketches, diagrams and other changes as may become necessary during the progress of work, shall also be maintained and attached to the record drawings.
- C. At completion of the Work Order, the marked up “record” drawings plus all record field sketches and diagrams shall be submitted to the Engineer for his review according to Section 01 33 10 Submittal Procedures. Record documents will be used establishing a basis for final payment.
- D. All record documents are required for Contract closeout. Refer to Section 01 77 19 Closeout Requirements.

1.3 CHANGES TO RECORD

- A. Examples of type of changes which could occur and information that is to be recorded, without limitation, are:
  - 1. Change in alignment, slopes, distances, and inverts of sewer pipes.
  - 2. Final location of manholes including final rim and invert elevations.
  - 3. Measured location and elevations of underground utilities and/or relocated

defective work associated with the Contract or supplying work not yet completed,  
in accordance with GC Article 15.08.

PART 2 PRODUCTS

NOT USED

PART 3 EXECUTION

NOT USED

END OF SECTION

**SECTION 01 77 23  
POST-FINAL INSPECTION**

PART I GENERAL

1.1 SUMMARY

- A. This section describes requirements after the final inspection, performed in accordance with GC Article 15.05, in order to complete the Contract for final payment, in accordance with GC Article 15.06.
- B. Related Sections:
  - 1. Section 01 78 23 – Operations and Maintenance Data

1.2 GENERAL

- A. Acceptance of the Work by Owner's representative during the Work, or Engineer during final inspection, shall not relieve Contractor from their obligation to complete all work included in the Contract.
- B. Final inspections may be required for individual Work Orders dependent on the nature and scope of the work.
- C. Following the final inspection, Contractor shall promptly remove from the premises all defective work, determined by Engineer in the final inspection as failing to conform to the Contract.
- D. Contractor shall bear the expense of correcting work damaged or destroyed by any worker under their control at any point during the Work, including damage due to removal of defective work and any damage after final inspection.
- E. Contractor shall promptly complete remaining work identified by Engineer in the final inspection, in accordance with the Contract.
  - 1. Owner's representative must be present to witness correction or completion of remaining work, unless otherwise approved in writing.
  - 2. Engineer will determine if remaining work has been completed in accordance with the Contract Documents.
  - 3. Final paperwork will not be issued until all Contract work is complete, as determined by Engineer.
- F. Neither final inspection, nor issuance of the final certificate or payment, nor any acceptance of the Work, shall relieve Contractor of responsibility correcting any

2. Form of Guarantee
  3. Engineer's Certificate
  4. Prime Contractor Certificate (PICC-2)
  5. Subcontractor Certifications (PICC-1)
  6. Final Change Order
  7. All required Equal Employment Opportunity (EEO) Reports
  8. All required EEO Certificates
  9. Weekly Payroll Certifications
- E. All documents must be completed and executed by Contractor prior to Contract close-out and release of final payment. Final payment will not be issued until all forms have been properly executed by Contractor and all their Subcontractors, as applicable.

#### 1.6 FINAL PAYMENT

- A. In the final estimate, final measurements for unit prices will be determined based on Section 01 22 13 Unit Price Measurement and Payment. All estimates including the final, will be made for actual quantities of work performed and materials in place as determined by the measurement of Engineer. Payment shall be as described in Section 01 22 13 Unit Price Measurement and Payment.
- B. The acceptance by Contractor of final payment shall be, and shall operate as, a release to Owner of all claims and all liability to Contractor for all things done or furnished in connection with the Work, and for each act and neglect of Owner and others relating to or arising out of the Work. No payment, however, final or otherwise, shall operate to release Contractor or his sureties from any obligations under this Contract, the Performance Bond or the Payment Bond.

#### PART 2 PRODUCTS

NOT USED

#### PART 3 EXECUTION

NOT USED

END OF SECTION

the final Change Order.

- C. Contractor shall guarantee the Work, including parts, labor, materials and equipment, in accordance with GC Article 15.08 and as amended by the Supplementary Conditions.
- D. Owner, Engineer and Contractor shall each sign and date the Statement of Completion attesting that the Work has been completed satisfactory and the final compensation amount is correct.
- E. The Work must be accepted on or before the Contract Times expire, as established in the Contract and with any approved extensions thereof. Any change in the Contract Times to be included in the final Change Order must be approved in writing before the Contract Times expire.
- F. When the Project has been completed in accordance with the Contract Documents, within the established time of completion, and has been accepted, final payment will be recommended in accordance with the procedures in GC Article 15.06, and as amended by the Supplementary Conditions.

#### 1.5 CLOSE OUT DOCUMENTS

- A. Upon completion of the Work, Contractor shall be required to execute a Public Improvement Contract Certification for (PICC-2) certifying that the provisions of Section 220-a of the New York State Labor Law have been complied with and that all laborers, workers or mechanics employed by Contractor on this Project have been paid the applicable prevailing wage rates and supplements.
- B. Upon completion of the Work, all Subcontractors to Contractor shall be required to execute a Public Improvement Contract Certification form (PICC-1) certifying that the provisions of Section 220-a of the New York State Labor Law have been complied with and that all laborers, workers or mechanics employed by the Subcontractor for this Project have been paid the applicable prevailing wage rates and supplements.
- C. Contractor shall furnish to Owner duplicate copies of all weekly payroll certifications, including those of all Subcontractors, that were not previously submitted. Payrolls shall be submitted in accordance with the procedures in Section 01 29 76 Progress Payment Procedures.
- D. Contractor shall complete and submit all necessary Contract closeout certifications and affidavits as required by Owner to include, without limitation:
  - 1. Form of Affidavit



**SECTION 01 77 19  
CLOSEOUT REQUIREMENTS**

**PART 1 GENERAL**

**1.1 SUMMARY**

- A. This section describes general requirements related to administrative procedures to close out an individual Contract.
- B. Related Sections:
  - 1. Section 01 22 13 – Unit Price Measurement and Payment
  - 2. Section 01 29 76 – Progress Payment Procedures
  - 3. Section 01 78 39 – Project Record Documents

**1.2 GENERAL**

- A. Closeout of the Contract cannot occur until the respective Contractor provided all required materials in accordance with submitted record documents in accordance with Section 01 78 39 Project Record Documents.
- B. Closeout will only occur after Substantial Completion, as defined and according to procedures established in the General Conditions, and after all other components of the has been completed.

**1.3 WORK ORDER COMPLETION**

- A. Following the completion of individual Work Orders, final inspections at each site will be scheduled at the discretion of the Engineer based on the nature and the scope of the work.
- B. Work Orders will be designated as substantially complete consistent with the definition in Section 00 72 13 General Condition Paragraph 1.01 A 42. Work Orders will be designated as complete when all restoration work and corrective work has been completed.

**1.4 PROJECT COMPLETION**

- A. Upon completion of the Work, Engineer shall file a written Statement of Completion with Owner, and with Contractor, as to the entire amount of work performed and compensation earned by Contractor, including any extra work and excluding any work not performed or contingency allowances not used.
- B. Failure to complete the Work as described in the Contract Documents, as determine by Engineer, may be cause for adjustment in the Contract Price under

1.3 FINAL CLEANING

- A. Prior to the inspection described in Section 01 77 23 Post Final Inspection, the Work and the Site shall be cleaned and all excess materials shall be removed from the Site. Remove dirt, dust, litter, corrosion, solvents, discursive paint, stains, and extraneous markings from all areas of and components included in the Work.
- B. At the conclusion of the Work and before final payment, all equipment, tools, temporary structures, and materials belonging to Contractor shall be removed from the Site. All water, dirt, rubbish, or any other foreign substances shall be removed and properly disposed of.

PART 2 PRODUCTS

NOT USED

PART 3 EXECUTION

NOT USED

END OF SECTION

**SECTION 01 74 10  
CLEANING AND WASTE MANAGEMENT**

**PART 1 GENERAL**

**1.1 SUMMARY**

- A. This section includes requirements for progress cleaning, site management, construction waste management and disposal and final cleaning at the Site.
- B. Related Sections:
  - 1. Section 01 35 43.13 – Environmental Procedures for Hazardous Materials
  - 2. Section 01 77 23 – Post Final Inspection

**1.2 GENERAL**

- A. Contractor is responsible for progress cleaning, construction waste management and disposal, and final cleaning related to, without limitation:
  - 1. Any area of the site where the Work is in progress or completed.
  - 2. Facilities in use by Contractor, including Owner's facilities.
  - 3. Areas of the site where those under the control of Contractor park, congregate or otherwise use the Site.
  - 4. Areas of the Site used by Contractor for access.
- B. During construction of the Work, Contractor shall remove material, debris and rubbish if directed by Engineer or Owner.
- C. Contractor shall remove all surplus materials and temporary structures when no longer in use.
- D. Off-site disposal of construction and demolition debris shall be handled in accordance with all applicable regulations. In no case shall such debris be disposed of in water bodies, flood plains or wetlands.
- E. Contractor shall provide the appropriate containers for construction waste and those shall be the only containers used by Contractor, unless otherwise agreed to in writing.
- F. Materials on site that have an SDS as described in Section 01 35 43.13 Environmental Procedures for Hazardous Materials shall be disposed of in accordance with the SDS.

exposed on the exterior or in occupied spaces in a manner that would degrade the building's aesthetic qualities.

- E. Contractor shall remove and replace visually unsatisfactory cut and patched construction.

### 1.3 CUTTING

- A. Prior to cutting, Contractor shall determine all utility, mechanical, and electrical services that will be impacted. Contractor shall coordinate any relocation or loss of service with Engineer.
- B. Where cutting will impact structural reinforcement, Contractor shall submit drawings for reinstallation of reinforcement during patching in accordance with Section 01 33 10 Submittal Procedures. Contractor shall not cut and patch structural elements in a manner that could change the load-carrying capacity or load-deflection ratio. A structural element includes any load-bearing, lateral force-resistant member, and wind or seismic movement resisting construction.
- C. Contractor shall take precautions and exercise care to ensure work is neatly removed and without movement or settlement to the remainder of the building, or any other damage to property or facilities. Contractor is liable for any damage caused as a result of their operations.

### 1.4 PATCHING

- A. Only products approved in accordance with Section 01 33 10 Submittal Procedures shall be used for patching.
- B. Contractor shall not patch in a manner that could change load-carrying capacity; which results in a reduction of capability to perform as intended; or that results in increased maintenance or decreased operational life or safety.

## PART 2 PRODUCTS

NOT USED

## PART 3 EXECUTION

NOT USED

END OF SECTION

**SECTION 01 73 29  
CUTTING AND PATCHING**

**PART 1 GENERAL**

**1.1 SUMMARY**

- A. This section includes procedural requirements for removal of in-place construction necessary to permit installation of other work (cutting) or fitting and repair work required to restore surfaces to original conditions after installation of other work (patching).
- B. Related Sections:
  - 1. Section 01 33 10 – Submittal Procedures
  - 2. Section 01 71 34 – Protection of Work and Property

**1.2 GENERAL**

- A. Contractor is responsible for all cutting, fitting, and patching required for alteration work or to correct or modify newly installed construction, including without limitation:
  - 1. Coordination between Contracts.
  - 2. Completing the Work for integration with other work.
  - 3. Uncovering portions of the Work to provide for installation of other work.
  - 4. Removing and replacing defective work.
  - 5. Removing and replacing work not in conformance with the Contract Documents.
  - 6. Removing samples of installed work as necessary for testing.
  - 7. Providing penetrations for installation of materials (such as piping and electrical conduit).
- B. Contractor shall not perform cutting and patching operations that could void any warranty.
- C. Contractor shall conform with Section 01 71 34 Protection of Work and Property when performing any cutting or patching operation.
- D. Contractor shall not cut and patch construction in a manner that results in visual evidence of cutting and patching. Contractor shall not cut and patch construction

**SECTION 01 73 24**  
**CONNECTIONS TO EXISTING FACILITIES**

PART 1 GENERAL

1.1 SUMMARY

- A. This section includes requirements regarding connecting to Owner facilities.
- B. Related Sections:
  - 1. Section 01 14 17 – Coordination with Owner’s Operations
  - 2. Section 01 71 34 – Protection of Work and Property

1.2 GENERAL

- A. All connections to existing facilities shall be coordinated with Owner in accordance with Section 01 14 17 Coordination with Owner’s Operations.
- B. All existing facilities shall be protected in accordance with Section 01 71 34 Protection of Work and Property.
- C. Contractor shall plan and prepare for all connections to existing facilities in advance. Contractor shall have everything readily available to complete the connection, in the shortest time possible, and to handle all emergencies normally encountered in such a connection.
- D. Contractor shall review connection plan with Engineer in advance of any connection attempt.

1.3 SANITARY SEWER FACILITIES

- A. When connecting to sanitary sewer facilities, no amount of sewage shall be allowed to discharge onto land or property.
- B. The appropriate pitch shall be maintained when making the connection. Unless otherwise specified, connections cannot change the direction or pitch of the flow.
- C. Connection of two facilities of different sizes shall not be allowed unless otherwise specified or approved in writing.

PART 2 PRODUCTS NOT USED

PART 3 EXECUTION NOT USED

END OF SECTION

**SECTION 01 73 19  
INSTALLATION**

PART 1 GENERAL

1.1 SUMMARY

- A. This section includes requirements regarding installation of components of the Work.
- B. Related Sections:
  - 1. Section 01 33 10 – Submittal Procedures

1.2 GENERAL

- A. Contractor shall supply all necessary tools and machinery appropriate for installation of the Work. Owner tools, equipment, machinery or other facilities shall not be used unless otherwise specified or approved in writing.
- B. Contractor shall have on-hand sufficient tools and machinery of ample capacity to facilitate the Work and to handle all emergencies normally encountered in work of this character. Contractor shall only use tools or machinery intended to perform the necessary task.
- C. Contractor shall install components at the time and under conditions that will ensure the best possible results. Contractor shall maintain conditions required for product performance until acceptance of the Work.
- D. Work components shall be installed at the locations and elevations shown on the Plans unless directed otherwise by Engineer. Contractor shall make vertical work plumb and horizontal work level, unless otherwise specified.
- E. Where space is limited, Contractor shall orient work components to provide for maximum space to perform maintenance and for ease of removal of components.
- F. Manufacturer's installation instructions, where available, shall be followed.

PART 2 PRODUCTS

NOT USED

PART 3 EXECUTION

NOT USED

END OF SECTION

Contractor operations in accordance with Section 01 74 10 Cleaning and Waste Management.

- B. Contractor shall be responsible for closing, roping off, or otherwise controlling access to the work areas during construction to prevent damage to the Work and property.

PART 2 PRODUCTS

NOT USED

PART 3 EXECUTION

NOT USED

END OF SECTION



**SECTION 01 71 34**  
**PROTECTION OF THE WORK AND PROPERTY**

PART 1 GENERAL

1.1 SUMMARY

- A. This section includes requirements associated with protection of the Work, public property, private property, and Owner facilities and property.
- B. Related Sections:
  - 1. Section 01 14 17 – Coordination with Owner’s Operations
  - 2. Section 01 74 10 – Cleaning and Waste Management

1.2 GENERAL

- A. Contractor shall be responsible for taking all precautions, providing all programs, and taking all action necessary to protect the Work and all public and private property and facilities from damage.
- B. Contractor shall not, except for written consent from proper parties, enter or occupy with workers, tools, materials or equipment, privately-owned land. Operations are to be restricted to the Site described in the Contract Documents.
- C. Contractor shall assume full responsibility for the preservation of all public and private property or facilities on or adjacent to the Site. Any direct or indirect damage is done by or on account of any act, omission, neglect or misconduct in the execution of the Work by Contractor shall be restored by Contractor to a condition equal to or better than that existing before the damage was done.
- D. Where work includes direct or indirect contact with wastewater, Contractor shall take precautions to prevent unnecessary contact between wastewater and the Work, facilities or property.

1.3 SITE REQUIREMENTS

- A. In order to prevent damage, injury or loss, Contractor’s actions shall include, but not be limited to, the following:
  - 1. Coordinate work with Owner’s operations in accordance with Section 01 14 17 Coordination with Owner’s Operations.
  - 2. Place upon the Work or existing facilities only such loads as are consistent with the capacity of the components to bear those loads.
  - 3. Clean up frequently all refuse, rubbish, scrap materials, and debris caused by

NOT USED

PART 3 EXECUTION

3.1 SURVEY

- A. Verify layouts as the Work proceeds to assure compliance with required lines, levels, and tolerances.
- B. Upon request, Contractor shall submit documentation to verify accuracy of field engineering work.

3.2 RECORDS

- A. Contractor shall maintain a complete and accurate log of all control and survey as the Work progresses. Construction survey notes shall be provided to Engineer upon completion of survey work.
- B. Upon completion of foundation walls and major site improvements, Contractor shall prepare a certified survey showing all dimensions, locations, angles, and elevations of construction, unless otherwise specified.
- C. Upon completion of the Project, Contractor must provide a certification, signed by licensed surveyor or other certifying authority, certifying that elevations and locations of improvements are in conformance or nonconformance with requirements of the Work Order Documents.

END OF SECTION

- G. All required documents shall be submitted in accordance with Section 01 78 39 Record Documents.

### 1.3 SURVEY REQUIREMENTS

- A. Surveying services and field engineering services shall be performed under the supervision of a licensed land surveyor, unless otherwise specified or agreed to in writing.
- B. Basic horizontal and vertical control points for the Work will be established from existing structures.
- C. Locate and protect control points prior to beginning the Work, and preserve all permanent reference points throughout the Work.
- D. Establish lines and levels, locate, and lay out:
  - 1. Site improvements.
    - a. Stakes for grading and fill placement.
    - b. Utility slopes and invert elevations.
  - 2. Batter boards for structures.
  - 3. Building foundations, column locations, and floor levels.
  - 4. Controlling lines and levels required for mechanical and electrical Work.
- E. The Contractor shall provide for the duration of the project, for use by the Engineer and/or Owner's representative, a surveying level with minimum accuracy of 0.1 distance in miles and a level rod of sufficient length to obtain invert elevations for each section of proposed sewer pipe laid. All equipment shall be subject to the Engineer's review. Prior to acceptance of said equipment by the Engineer, all equipment shall be calibrated and certified, by a qualified survey equipment firm, that said equipment is in first class condition. The Contractor shall also provide the use of one man to assist in obtaining all elevations when needed

### 1.4 SUPPORT AND BRACING

- A. Contractor shall provide all support and bracing systems necessary to complete the Work as indicated in the Contract Documents. Support and bracing shall not over stress any component of the Work or existing facilities.

## PART 2 PRODUCTS

**SECTION 01 71 23**  
**FIELD ENGINEERING**

PART 1 GENERAL

1.1 SUMMARY

- A. This section includes requirements for survey and survey related activities performed in the course of the Work.
- B. Related Sections:
  - 1. Section 01 78 39 – Project Record Documents

1.2 GENERAL

- A. In general, work assigned under this Contract is primarily anticipated to be spot repairs or replacement in-kind work. Pipe or structures to be replaced or repaired will be marked or otherwise identified by the Owner in the field.
- B. Where work order assignments consist of new installations or replacement in a new alignment, the Owner shall provide all survey work required for horizontal and vertical location of all Work in the Project. The Owner will establish bench marks, base lines, and other principal controlling points and set grade stakes every 100 feet of improvements and at manholes. The Owner will perform stakeout once only per worksite. The Contractor shall check such lines and grades and call the Engineer's attention to any inaccuracies. The Contractor shall furnish and maintain, at his own expense, stakes and lath and give assistance including qualified helpers, as shall may be required by the Engineer for setting and checking line and grade. The stakes shall be of hardwood, dry and 2 inch x 2 inch x 24 inch long with pointed end. The lath shall be hardwood ½ inch x 2 inch x 4 feet long with pointed end. Materials to be used by the Engineer shall be delivered to the site of the work, where stakeout is required.
- C. Contractor shall install all work to lines and grades in accordance with Work Order Documents.
- D. Location shall be staked from lines shown on the Work Order Drawings. Mark the limits of the Site and obtain utility locations before beginning clearing or excavation.
- E. Contractor shall be responsible for replacement and reestablishment of control stakes, monuments, and lines destroyed or disturbed by Contractor's activities.
- F. Generally, grades shall match adjacent surfaces, and existing flow lines shall be maintained.

PART 2 PRODUCTS

NOT USED

PART 3 EXECUTION

NOT USED

END OF SECTION

- B. Unnecessary materials or equipment shall not be stored on the Site.
- C. Store apparatus, materials, supplies and equipment in a safe, orderly manner that does not interfere with the Work or normal operations of the surrounding areas.
- D. Storage shall not block access in areas of egress.
- E. Store materials that are subject to injury by exposure to weather, theft, breakage or otherwise.
- F. Limited storage may be available on the Site. Owner will not be responsible for any items stored in their facilities.
- G. Store products in such a manner that it can be easily inspected. Inspect stored products at regular intervals to ensure that damage has not occurred or is not occurring. Engineer has the right to inspect stored materials at any time.
- H. Materials stored upon streets or roads shall be so placed as to cause minimum obstruction to traffic and the public. Materials stored upon streets or roads are subject to the approval of the agency having jurisdiction of the roadway. Materials shall not be placed within 10 feet of fire hydrants. Gutters and drainage inlets shall be kept unobstructed at all times.
- I. Contractor shall not store materials or encroach upon private property without the written consent of the owners of such private property.
- J. Contractor storage facilities or apparatus, or any items stored in Owner facilities, must be removed in a timely manner following the Final Inspection. Refer to Section 01 77 23 Post Final Inspection for any requirements.

#### 1.4 HANDLING

- A. Contractor shall place upon the Work, or any part thereof, only such loads as are consistent with the safety of that portion of the Work.
- B. Contractor shall provide such vehicles, equipment or apparatus that is required to safely and securely, without damage, handle materials associated with the Work.
- C. Owner may have equipment or apparatus that can assist in the handling of products used in the Work. Owner equipment and apparatus cannot be used without prior written consent. When Owner equipment or apparatus is used, Contractor must obtain written certification of the condition of such before and after use. Contractor is responsible to repair damage to Owner equipment or apparatus, and such repair must be completed by a certified repair specialist, as recommended by the manufacturer.

**SECTION 01 166 00**  
**PRODUCT STORAGE AND HANDLING REQUIREMENTS**

PART 1 GENERAL

1.1 SUMMARY

- A. This section includes considerations for the storage and handling of products related to the Work or Contractor's execution of the Work.
- B. Related Sections:
  - 1. Section 01 14 19 – Use of Site
  - 2. Section 01 57 33 – Security
  - 3. Section 01 65 00 – Product Delivery Requirements
  - 4. Section 01 77 23 – Post Final Inspection

1.2 GENERAL

- A. Products delivered according to Section 01 65 00 Product Delivery Requirements must be handled and stored in such a manner such that no damage to the product shall occur.
- B. Handling and storage shall be in accordance with manufacturer's instructions and any other specific requirements for handling and storage included in the Contract Documents.
- C. Locations of storage shall conform with Section 01 14 19 Use of Site
- D. Contractor is responsible for the secure storage of products, materials and other items used in the Work in accordance with Section 01 57 33 Security.
- E. Contractor is responsible to repair any damage that occurs to products, the Work or adjacent facilities during storage and handling.
- F. Damaged items shall not be used in the Work unless written permission is obtained to allow for use. Damage shall include indentations, rusting or other surface damage or deterioration.

1.3 STORAGE

- A. Contractor shall store his equipment and materials at the Site in a manner acceptable to Owner and Engineer, and in conformance with applicable statutes, ordinances, regulations and rulings of proper public authority. Contractor shall enforce the instructions of Owner and Engineer respecting signs, advertisements, fire and smoking.

### 1.3 INSPECTION

- A. Delivered products shall be inspected by Contractor for damage before placing in storage or prior to implementation into the Work. Contractor is responsible for replacement or repair, as determined by Engineer, of damaged products.
- B. Inspect delivered products to ensure that they conform with the Contract Documents and the product approvals obtained in accordance with Section 01 33 10 Submittal Procedures. Products not in compliance with Contract Documents and Shop Drawings will be directly returned to manufacturer by Contractor and shall not be implemented into the Work.
- C. Engineer and Owner have the right to inspect delivered materials.

### PART 2 PRODUCTS

NOT USED

### PART 3 EXECUTION

NOT USED

END OF SECTION



**SECTION 01 165 00**  
**PRODUCT DELIVERY REQUIREMENTS**

PART I GENERAL

1.1 SUMMARY

- A. This section includes considerations for the delivery of products related to the Work.
- B. Related Sections:
  - 1. Section 01 14 19 – Use of Site
  - 2. Section 01 33 10 – Submittal Procedures
  - 3. Section 01 66 00 – Product Storage and Handling Requirements

1.2 GENERAL

- A. Delivery of products shall be scheduled so that storage time on the Site will be minimized.
- B. Deliveries shall only occur during normal working hours unless otherwise approved in writing.
- C. Contractor must have personnel on the Site authorized to accept deliveries when deliveries occur. Owner or Engineer will not accept deliveries of products on behalf of Contractor unless prior written agreement has been obtained.
- D. Contractor contact information shall be provided to shipping company. Owner contact information shall not be used for shipping unless otherwise agreed to in writing.
- E. Locations of deliveries shall conform with Section 01 14 19 Use of Site and any other requirements listed in the Contract Documents.
- F. Products delivered to the Site must be handled and stored in accordance with Section 01 66 00 Product Storage and Handling Requirements.
- G. Contractor shall provide such vehicles, equipment or apparatus that is required to safely and securely, without damage, accept products from the delivery.
- H. Deliveries shall be in conformance with applicable statutes, ordinances, regulations and rulings of proper public authority.
- I. Unnecessary materials or equipment shall not be delivered to the Site.
- J. Deliveries shall not block access in areas of egress of persons or vehicles.

Contractor observes that the Contract Documents are at variance therewith, Contractor shall promptly notify Engineer in writing and any necessary changes shall be adjusted as to the additional work and changes.

- C. If Contractor's methods of construction require that additional permit(s) be obtained, the cost for such permits and any delays in construction associated therewith shall be borne by Contractor.
- D. Codes and regulations referenced in the Contract Documents are not a comprehensive list of all that is applicable to the Work. The codes and regulations listed in the Contract Documents are referenced for the information and convenience of the Contractor. Not all codes or regulations applicable to the Work have been cited or adequately described in the Contract Documents. Contractor is responsible for compliance with all codes and regulations applicable to the Work and relevant to the Contractor's means and methods of performing the Work.

#### 1.4 STORMWATER CONTROL

- A. Requirements for stormwater control are described in Section 01 41 28 Stormwater Pollution Prevention. The requirements are based on NYSDEC guidance and permitting.

#### 1.5 WORK IN PROXIMITY TO WATER BODIES

- A. If the Owner has obtained permits for work related to water bodies (such as USACE / NYSDEC Joint Permit or SPDES General Permit for Construction), the permits will be provided with the Work Order.
- B. All work in the vicinity of water bodies shall meet the following minimum standards:
  - 1. Work shall not obstruct the upstream and downstream movement of fish. Temporary culverts shall be as nearly as possible, flush with the stream bed.
  - 2. Sufficient flow of water shall be maintained at all times to sustain aquatic life downstream.
  - 3. Any temporary culvert of diversion channel shall provide a "V" or "dish-shaped" channel, to concentrate flow during periods of low water and facilitate the movement of fish.
  - 4. Disturbance of the stream bed shall be kept to an absolute minimum and the stream bed shall be returned, as nearly as possible, to its original condition, or better. (Where possible, in modifying a stream bed, the centerline shall be 8"

**SECTION 01 41 05  
REGULATORY REQUIREMENTS**

**PART 1 GENERAL**

**1.1 SUMMARY**

- A. This section includes references to federal, state and local regulations, information on requirements included in regulations and associated permitting.
- B. Related Sections:
  - 1. Section 01 33 10 – Submittal Procedures
  - 2. Section 01 35 26.23 – Confined Space Entry Plan
  - 3. Section 01 35 28 – Contractor’s Health and Safety Plan
  - 4. Section 01 35 43.13 – Environmental Procedures for Hazardous Materials
  - 5. Section 01 41 28 – Stormwater Pollution Prevention
  - 6. Section 01 45 33 – Code-Required Special Inspections and Procedures
  - 7. Section 01 77 19 – Closeout Requirements

**1.2 ABBREVIATIONS**

- A. CFR – Code of Federal Regulations
- B. DEC – Department of Environmental Conservation
- C. DOT – Department of Transportation
- D. DPW – Department of Public Works
- E. EPA – United States Environmental Protection Agency
- F. NYS - New York State
- G. OSHA – Occupational Safety and Health Administration
- H. SPDES - State Pollution Discharge Elimination System
- I. USACE – United States Army Corps of Engineers

**1.3 GENERAL**

- A. Permits, licenses and easements for permanent structures or permanent changes in existing facilities will be secured and paid for by Owner, unless otherwise specified.
- B. Contractor shall give all notices and comply with all laws, ordinances, rules and regulations bearing on the conduct of the Work as drawn and specified. If

**SECTION 01 64 00  
OWNER-FURNISHED PRODUCTS**

PART 1 GENERAL

1.1 SUMMARY

- A. This section includes provisions related to products incorporated into the Work by Contractor that are furnished by Owner
- B. Related Sections:
  - 1. Section 01 29 73 – Schedule of Values
  - 2. Section 01 32 33 – Photographic Documentation

1.2 GENERAL

- A. Where products are specified as “Supplied by Owner”, or any similar phrase, Contractor shall not include material cost of such products in their Schedule of Values as required in Section 01 29 73 Schedule of Values. Cost of installation or incorporation into the Work shall be included the Schedule of Values.
- B. Owner or Engineer will supply sufficient information on the furnished product to enable Contractor to incorporate the product into the Work. Owner furnished products shall be installed according to manufacturer’s instructions. If additional information is needed, Contractor shall notify Engineer immediately.
- C. Owner will deliver furnished products to the Site, unless stated otherwise.
- D. At the beginning of the Project and before incorporation into the Work, Contractor shall document the condition of Owner-furnished products with photographs complying with Section 01 32 33 Photographic Documentation. Contractor shall document function, if able to do so. Failure to properly document condition prior to and during the Work may make Contractor liable for any damage to the Owner-furnished products.
- E. Contractor shall treat Owner-furnished products with the same care as those supplied by Contractor.

PART 2 PRODUCTS

NOT USED

PART 3 EXECUTION

NOT USED

END OF SECTION

### 1.3 PRODUCT SAMPLES

- A. Where Contract Documents require matching a sample, the decision by Engineer or Owner on whether a proposed product matches shall be final. Where no product visually matches, but the product complies with other requirements, comply with Section 01 25 13 Product Substitution Procedures for selection of a matching product in another category.
- B. Where Contract Documents require selection from manufacturer's standard colors, patterns or textures, selections of products will be made by indicated party or, if not indicated, by Engineer. Engineer will select color, pattern and texture from the product line of submitted manufacturer, if all other specified provisions are met.

### PART 2 PRODUCTS

NOT USED

### PART 3 EXECUTION

NOT USED

END OF SECTION

**SECTION 01 62 00**  
**PRODUCT OPTIONS**

PART 1 GENERAL

1.1 SUMMARY

- A. This section includes product option requirements for products incorporated into the Work by Contractor.
- B. Related Sections:
  - 1. Section 01 25 13 – Product Substitution Procedures
  - 2. Section 01 33 10 – Submittal Procedures
  - 3. Section 01 42 00 - References
  - 4. Section 01 61 00 – Common Product Requirements

1.2 GENERAL

- A. Items specified by dimensions shall not exclude the furnishing of such items other than the specified dimensions where the quality, use and serviceability of the material is the same or equal. However, Contractor is responsible for adjusting work according to any differing dimensions as specified in Section 01 61 00 Common Product Requirements.
- B. Where an option is specified for a product and Contractor would like to propose an alternate option, that alternate may be considered a substitution and may be subject to the requirements of Section 01 25 13 Product Substitution Procedures.
- C. Where Contract Documents describe a product, listing characteristics required, with or without use of a brand name, a product shall be provided that has the specified attributes and otherwise complies with specified requirements.
- D. Where Contract Documents require compliance with performance requirements, product(s) shall be provided that comply and are recommended by the manufacturer for the intended application. Verification of manufacturer's recommendations may be by product literature or by certification of performance from manufacturer.
- E. Where Specifications require compliance with a standard, provided product shall fully comply with the standard specified. Refer to general requirements specified in Section 01 42 00 References regarding compliance with referenced standards, standard specifications, codes, practices and requirements for products.
- F. Selected options for products shall be identified in all submittals in accordance with Section 01 33 10 Submittal Procedures.

It is Contractors responsibility to identify the differences and adjust the Work accordingly or submit modifications for approval. Contractor shall be responsible for the cost of all modifications for equipment or materials that were not the basis of design, unless otherwise stated in the Contract Documents, the basis of design equipment or materials were not available, or their use was determined to be detrimental to the project by Engineer.

PART 2 PRODUCTS

NOT USED

PART 3 EXECUTION

NOT USED

END OF SECTION

- G. Where specific products are not specified, provide standard products of types and kinds that are suitable for the intended purposes and that are usually and customarily used on similar projects under similar conditions. If standard products cannot be determined or if more than one standard product is available, Contractor shall verify use of any product with Engineer.

### 1.3 SOURCES OF MATERIALS

- A. Upon request, Contractor shall furnish Engineer, in writing, the names and addresses of manufacturers or dealers from whom Contractor intends to secure materials.
- B. Any material ordered or delivered at the Site without prior approval is subject to rejection. Awards made by Contractor and proceeding with work under any item without satisfactory review of the materials, manufacturer or vendor by Engineer is at Contractor's own risk.
- C. Engineer's satisfactory review, when given, will be only on the basis of the manufacturer's experience and similar considerations specified herein, and will in no way imply that the material or equipment submitted will be satisfactory unless full compliance with the Contract Documents is demonstrated to Engineer's satisfaction through the submittal process outlined in Section 01 33 10 Submittal Procedures.
- D. All products and materials used in the Work shall be new stock or procured for this Project; refurbished or salvaged materials shall not be permitted.
- E. To the fullest extent possible, provide products of the same kind from a single source. Products required to be supplied in quantity shall be the same product and interchangeable throughout the Work. When options are specified for the selection of any of two or more products, the product selected shall be compatible with products previously selected.

### 1.4 COMPATIBILITY

- A. All supplied equipment and materials shall be compatible. If specified materials are not compatible, Contractor will notify Engineer.
- B. If a Substitution is approved in accordance with Section 01 25 13 Product Substitution Procedures, all installation procedures, associated materials and equipment shall be provided to be compatible with the substitution. It is Contractor's responsibility to ensure compatibility.
- C. Contract Documents will indicate the basis of design. Dimensions and other physical characteristics may slightly vary depending on manufacturer submitted.



**SECTION 01 61 00  
COMMON PRODUCT REQUIREMENTS**

**PART 1 GENERAL**

**1.1 SUMMARY**

- A. This section includes requirements for products incorporated into the Work by Contractor.
- B. Related Sections:
  - 1. Section 01 25 13 – Product Substitution Procedures
  - 2. Section 01 33 10 – Submittal Procedures

**1.2 GENERAL**

- A. No materials or supplies for the Work shall be purchased by Contractor or by any Subcontractor subject to any chattel mortgage or under a conditional sale or other agreement by which an interest is retained by the seller. Contractor warrants that there is good title to all materials and supplies used in the Work.
- B. Each unit of equipment shall have the manufacturer's name or trademark on a corrosion-resistant nameplate securely affixed in a conspicuous place. The manufacturer's name or trademark may be cast integrally with stamp, or otherwise permanently marked upon the item of equipment. Such other information as the manufacturer may consider necessary to complete identification shall be shown on the nameplate.
- C. All materials or equipment delivered to the Site shall be accompanied by certificates, signed by an authorized officer of the manufacturing company, guaranteeing that the materials or equipment conform to specification requirements. Such certificates shall be immediately turned over to Engineer. Materials or equipment delivered to the Site without such certificates will be subject to rejection.
- D. Products shall be of commercial grade quality unless otherwise specified.
- E. Products shall not contain or produce materials that are known as hazardous, noxious, or harmful in nature. If design warrants such a product, hazards shall be fully disclosed when submitting a shop drawing for the product under Section 01 33 10 Submittal Procedures.
- F. Equipment, materials, and any related information shall be supplied in English units unless otherwise specified. Any data depicted on a nameplate or anything permanently affixed shall be in English units.

**SECTION 01 57 33**  
**SECURITY**

PART 1 GENERAL

1.1 SUMMARY

A. This section includes requirements for Contractor regarding site security.

B. Related Sections:

1. Section 01 66 00 – Product Storage and Handling Requirements

1.2 GENERAL

A. During the progress of the Work, and up to the date of final acceptance, Contractor shall bear all risk of loss and shall be solely responsible for the care and protection of all work and materials associated with this Contract.

B. Contractor is responsible for security required to protect all work and materials against damage, injury or loss from any cause. Contractor shall take responsibility for any such damage or loss due to lack of security.

C. Contractor shall supply secure storage facilities for materials involved in the Work in association with Section 01 66 00 Product Storage and Handling Requirements.

PRODUCTS

NOT USED

PART 3 EXECUTION

NOT USED

END OF SECTION

B. All connections to existing facilities or structures shall be removed with care and any damage to connection points shall be repaired.

END OF SECTION

shall be manufactured to the same specifications. Used pipe shall have the nominal pipe diameter, pipe size (iron pipe size-IPS or ductile iron pipe size-DIPS), and dimension ratio (DR) readily visible on each pipe segment, or otherwise readily identifiable. All HDPE pipe used for the temporary piping shall be of the same pipe size and dimension ratio, no exceptions. All pipe used for the temporary piping shall be free of gouges, cuts, scrapes or other physical deformities on the inside and outside barrel of the pipe equivalent to, or greater than, 10 percent in depth of a new pipe segment DR wall thickness.

- C. Shop-fabricated flexible hose less than 8 feet in length may be used to connect pumps to discharge manifold. If used, flexible hose shall have a minimum pressure rating based on the pump design.
- D. All temporary piping shall be pressure tested prior to performing any work requiring temporary pumping and operation of the temporary pumping system.

## PART 2 PRODUCTS

NOT USED

## PART 3 EXECUTION

### 3.1 INSTALLATION

- A. Contractor shall be responsible for furnishing the necessary material, equipment, labor and supervision to set up and operate the temporary pumping and piping systems. The temporary piping and pumping systems shall be fully inspected, prior to performing any work that requires temporary pumping, to ensure that the system is working correctly.
- B. Contractor shall pressure test the piping for leaks prior to use.

### 3.2 FLOW CONTROL

- A. Contractor shall be responsible and liable for any wastewater spills and overflows resulting from improper operation or inadequacy of the temporary pumping system, including reporting to Owner and paying the resulting fines and penalties

### 3.3 REMOVAL AND RESTORATION

- A. Contractor shall remove all temporary pumping system components and restore any modifications to the existing equipment or structures. Any soil containing grease, oil, or fuel from the pump engines shall be removed from the Site and replaced with topsoil and seeded or sodded. All pavement, grassed and landscaped areas shall be cleaned and restored to pre-construction condition.

dedicated to monitoring operation of the pumping system the entire time it is being operated.

- G. Temporary pumping system friction and minor losses and the appropriate size and number of pumps shall be determined by the temporary pumping vendor or Contractor licensed Professional Engineer in order to achieve the required flows.
- H. All pumps used shall be fully automatic self-priming units that do not require the use of foot-valves or vacuum pumps in the priming system. The pumps shall be diesel powered. Equipment shall be "residential silenced" equipped if it is intended to run past 5 pm.
- I. The temporary pumping system vendor shall provide diesel fuel storage and containment for the pumps. Contractor is responsible for providing fuel throughout the temporary pumping operations unless otherwise indicated in writing. The onsite fuel storage shall be sized to store enough fuel for running the system for a minimum of twice the anticipated time of use in a 7-day period, under full load, unless otherwise approved in writing.
- J. The proposed pumping systems shall meet the requirements of all codes and regulatory agencies having jurisdiction.
- K. Spare parts for all components of the system shall be kept onsite as required. Adequate hoisting equipment for each pump and accessories shall be maintained onsite or available to be onsite within 2 hours.
- L. All units shall be fully operational. Any unit which fails to operate at its rated capacity shall be repaired or replaced prior to starting the Work that requires temporary pumping. Contractor is advised that Owner has limited or no control over the maximum flows that will enter the system during temporary pumping.

#### 1.4 PUMPING DURATION

- A. Operating time of the pumps should be minimized as much as possible.
- B. Engineer makes no estimations of the time required, or need to provide, temporary pumping.

#### 1.5 PUMPING DISCHARGE

- A. The pump discharge and temporary piping may be of new or used materials and shall not leak during operation. Under no circumstances will aluminum "irrigation" type piping or solvent cemented PVC pipe be allowed.
- B. High density polyethylene (HDPE) pipe used for the pump discharge and temporary piping shall comply with the latest ASTM Specifications F-405, F-667, F-894 AND 2513 and AASHTO (M-294 Virgin Resins). Fittings and couplers

fencing, as a minimum, shall be provided around the pumping systems.

- I. Should the existing structures and facilities need modification to install connections, Contractor shall include this work. After the Work is complete, all repairs shall be performed to bring equipment and facilities back to their original condition.
- J. Contractor shall maintain flow around the work area in a manner that will not cause surcharging of sewers, damage to sewers and that will protect public and private property from damage and flooding.
- K. Contractor shall protect water resources, wetlands, and other natural resources.

### 1.3 SYSTEM REQUIREMENTS

- A. When work involves an active conveyance pipe, a temporary bypass pumping system will be required to convey wastewater and sewage temporarily from the existing upstream manhole to the existing downstream manhole.
- B. The design, installation, operation, and maintenance of the temporary pumping and piping systems shall be Contractor's responsibility. Contractor shall employ the services of a vendor who can demonstrate to Engineer that it specializes in the design and operation of temporary raw sewage bypass pumping and piping systems. The vendor shall provide at least five (5) references of projects of a similar size and complexity as this Project, performed by the vendor within the past three (3) years.
- C. The temporary pumping and piping specialty vendor shall have been in business for a minimum of 15 years. They shall have a major service center within 150 miles of the Site, with on-call maintenance and service staff available to respond onsite within 2 hours of notification.
- D. The approved temporary pumping specialty Contractors are:
  - 1. Xylem/Godwin/Flygt;
  - 2. Rain for Rent;
  - 3. or approved equal.
- E. Pump shall be capable of handling raw, unscreened, sanitary sewage containing solids and fibrous materials. Pumps shall be non-clog and shall be capable of passing 3-inch solids.
- F. The pumping system shall include all necessary controls and instruments to operate the system, and each pump, in automatic mode and provide alarms. If the pumping system is to be manually operated, Contractor must provide an employee

**SECTION 01 57 20**  
**TEMPORARY BYPASS PUMPING**

PART 1 GENERAL

1.1 SUMMARY

- A. This section includes requirements for Contractor wastewater pumping due to interruptions in Owner operations.
- B. Related Sections:
  - 1. Section 01 25 13 – Product Substitution Procedures
  - 2. Section 01 41 05 – Regulatory Requirements

1.2 GENERAL

- A. Contractor may propose a plan for the Work that does not require temporary pumping if all other aspects of the Work can be performed without it. If this involves more than means and methods and requires a Substitution, refer to Section 01 25 13 Product Substitution Procedures for restrictions and requirements.
- B. Contractor shall design, furnish, install, operate, maintain, and subsequently remove all temporary pumping and piping system(s) necessary to perform the Work in the Contract Documents.
- C. Contractor shall be responsible for any and all permits for transport, conveyance and/or disposal for wastewater or sewage outside of Owner's transmission or containment systems.
- D. Contractor shall comply with all applicable plans, regulations, and permits. Refer to Section 01 41 05 Regulatory Requirements.
- E. Contractor shall be responsible for all motor vehicle traffic and general public safety and protection related to temporary pumping.
- F. Contractor shall be responsible for any and all violation notices, fines and remediation measures as a result of wastewater spillage or discharge associated with temporary pumping.
- G. Contractor shall provide all trained and experienced labor and supervision for operating and maintaining the pumping and piping systems, and making appropriate connections to Owner's system, during the entire pumping operation.
- H. The security of pumping systems shall be provided by Contractor. Secured

- K. Contractor shall provide watchmen at particularly dangerous locations such as railroads, heavily traveled roadways and similar locations. Contractor shall provide the necessary traffic control equipment and flagmen for adequate traffic control where traffic is restricted to one (1) lane or where other conditions require or as required by permit conditions.
- L. Contractor shall provide and maintain warning signs and barricades as may be required for the safety of those employed in the Work or visiting the Site.
- M. Contractor shall give 48-hour notice to the fire and police departments, and school districts of his proposed operations including shutdowns.
- N. Contractor shall maintain vehicular and pedestrian traffic and protect the public from damage to person and property, within the limits of the Work, for the duration of the Contract.
- O. Access to private properties over driveways shall be maintained. Contractor shall be liable for any damage to private properties resulting from the Work or temporary access structures. Contractor shall provide ingress and egress to and from intersecting streets, homes, businesses and commercial establishments including any temporary pavement. Contractor shall maintain existing bus stops, if any, so passengers are reasonably accommodated.

PART 2 PRODUCTS

NOT USED

PART 3 EXECUTION

NOT USED

END OF SECTION



- B. All existing roads, streets, sidewalks, and traffic ways shall be kept open for the passage of traffic and pedestrians during the construction period unless otherwise approved by Owner, Engineer, or authority having jurisdiction.
- C. Contractor shall impact traffic as little as possible and shall provide suitable barricades, red lights, "danger" or "caution" signs at all places where the Work constitutes a hazard to the public. All barricades and obstructions along public roads shall be illuminated at night and all lights for this purpose shall be illuminated from sunset to sunrise.
- D. Arrangements for traffic protection and control, detours, barricades, danger signs and warning lights shall be provided in accordance with local jurisdictional authorities' requirements and the Manual of Uniform Traffic Control Devices by New York State Department of Transportation.
- E. Contractor shall provide, install, move, remove and maintain all signs, signals, barricades, flares, lights and all other equipment, service and personnel required to regulate and protect all traffic, and warn of hazards. Remove temporary equipment and facilities when no longer needed.
- F. When required to cross, obstruct or temporarily close an existing site road, street, sidewalk or traffic way, Contractor shall provide and maintain suitable detours or other approved temporary expedients for the accommodation of traffic. Closings shall be for the shortest time practical and passage will be restored immediately after the completion of the Work causing the obstruction or closure. Stopping traffic for more than five minutes shall not be permitted unless specifically authorized in writing from the authority having jurisdiction.
- G. Provide traffic control of haul routes to expedite traffic and to minimize interference with normal traffic.
- H. Traffic shall be maintained over a reasonably smooth traveled way which shall be so marked by signs, delineators or other methods so that any person unfamiliar with conditions is able to safely ride, drive or walk day or night with a minimum of discomfort and inconvenience over all or any portion of the roadway where traffic is maintained.
- I. Contractor shall maintain the traveled way in such a condition and conduct operations in such a manner that snow and ice may be readily controlled by others as and when necessary, and in such a manner that proper drainage is provided.
- J. Contractor shall provide temporary markings in accordance with the New York State Manual of Uniform Traffic Control Devices, as required by the agency having jurisdiction, or as shown on the plans and specifications.

**SECTION 01 55 33  
TRAFFIC CONTROL**

PART 1 GENERAL

1.1 SUMMARY

- A. This section includes considerations with respect to traffic control when working in or along a roadway.
- B. Related Sections:
  - 1. Section 01 14 33 – Work in Rights-of-Way
  - 2. Section 01 33 10 – Submittal Procedures
  - 3. Section 01 41 05 – Regulatory Requirements

1.2 GENERAL

- A. Work in and along roads shall include traffic control as required in permits for the Work issued by the agency of jurisdiction. Permits shall be obtained by Contractor in compliance with GC Article 7.09, Section 01 41 33 Work in Rights-of-Way, and Section 01 41 05 Regulatory Requirements.
- B. Traffic control plans shall be submitted in accordance with Section 01 33 10 Submittal Procedures whenever traffic control is required for the Work.
- C. Contractor shall consider the maintenance and protection of traffic and protection of the public during construction equally important as the construction. All work under this bid item shall be performed in accordance with the New York State Department of Transportation Standard Specification Section 619, latest revision.
- D. Contractor shall protect traffic from damage to person and property which may result directly or indirectly from a construction operation. The New York State Department of Transportation Specifications requirements of Section 107 “Legal Relations and Responsibility to Public” shall apply.
- E. Where requirements listed in the Contract Documents differ from the requirements of regulatory agencies or agencies of jurisdiction, the more stringent shall apply. Where requirements are in conflict, the regulatory requirements or requirements of the agency of jurisdiction shall take precedence.

1.3 TRAFFIC CONTROL PLAN REQUIREMENTS

- A. The maintenance and protection of traffic plan shall be prepared by an engineer licensed to practice in New York State, unless otherwise indicated in the Contract Documents or approved in writing.

marked by signs, delineators and/or other methods so that any person unfamiliar with conditions is able to safely ride, drive or walk day or night with a minimum of discomfort and inconvenience. Closings shall be for the shortest time practical and passage will be restored immediately after the completion of the Work impeding access.

- D. In addition, Contractor shall provide and maintain such other warning signs and barricades in other areas as may be required for the safety of those employed in the Work or visiting the Site.
- E. Refer to Section 01 14 19 Use of Site for information on easements and other requirements related to site access.
- F. Owner may need to use access roads for ongoing operations while the Work is being performed. Refer to Section 01 14 17 – Coordination with Owner’s Operations for additional information.

#### 1.4 PARKING

- A. Contractor parking shall only occur in authorized areas. Parking areas shall be determined prior to any work being performed at the Site.
- B. Contractor shall not park work or personal vehicles or equipment on private property unless writing authorization is obtained. Coordinate requirements related to private property adjacent to rights-of-way with Section 01 14 33 Work in Rights-of-Way.

### PART 2 PRODUCTS

NOT USED

### PART 3 EXECUTION

NOT USED

END OF SECTION

**SECTION 01 55 10**  
**VEHICULAR ACCESS AND PARKING**

PART 1 GENERAL

1.1 SUMMARY

- A. This section includes considerations for access and parking at the Site for vehicles and other motorized equipment.
- B. Related Sections:
  - 1. Section 01 14 17 – Coordination with Owner’s Operations
  - 2. Section 01 14 19 – Use of Site
  - 3. Section 01 14 33 – Work in Rights-of-Way

1.2 GENERAL

- A. Contractor shall provide and maintain access to fire hydrants free of obstructions.
- B. Contractor must provide access to all emergency vehicles including, without limitation, ambulances, police cars, and firefighting vehicles and equipment, traveling through or stopping at any part of the Site and will yield, to these vehicles and cease construction activities, as necessary.
- C. Contractor shall maintain the access and parking in such a condition and conduct operations in such a manner that snow and ice are controlled when necessary, and in such a manner that proper drainage is provided.
- D. Contractor shall clean and restore paving and other site features after construction use.

1.3 ACCESS

- A. Contractor shall only access the Site at authorized locations. General access locations shall be determined prior to any work being performed at the Site. Written authorization shall be obtained for any other required access.
- B. All existing roads, streets, sidewalks, and traffic ways shall be kept open for the passage of traffic and pedestrians during the construction period unless otherwise approved by Owner, Engineer, or authority having jurisdiction over same.
- C. When required to cross, obstruct or temporarily close an existing site road, street, sidewalk or traffic way, Contractor shall provide and maintain suitable detours or other approved temporary expedients for the accommodation of traffic. Traffic shall be maintained over a reasonably smooth traveled way which shall be so

**SECTION 01 52 19  
SANITARY FACILITIES**

PART 1 GENERAL

1.1 SUMMARY

- A. This section includes requirements for Contractor supplied sanitary facilities.

1.2 GENERAL

- A. Contractor shall provide a sanitary facility (toilet) in accordance with the minimum OSHA Safety and Health requirements. No bathroom facilities will be available for Contractor use from Owner.
- B. At a minimum, Contractor shall provide:
1. Toilet facilities with toilet paper.
  2. Water and cleanser or soap for washing.
  3. Antibacterial gel or liquid for sanitizing hands.
- C. Upon completion and acceptance of the Project, Contractor shall remove the facilities from the Site and, unless otherwise directed, shall restore all areas affected by installation to a condition equal to or better than that which existed before installation.

PRODUCTS

NOT USED

PART 3 EXECUTION

NOT USED

END OF SECTION

**SECTION 01 52 16  
FIRST AID FACILITIES**

PART 1 GENERAL

1.1 SUMMARY

- A. This section includes requirements for Contractor supplied first aid facilities and supplies.
- B. Related Sections:
  - 1. Section 01 35 28 – Contractor’s Health and Safety Plan

1.2 GENERAL

- A. Each Contractor shall provide all necessary first aid supplies and facilities for general minor injuries and for potential project-specific injuries based on hazards identified in the Contractor Health and Safety Plan (as required in Section 01 35 28 Contractor’s Health and Safety Plan).
- B. Contractor shall supply all necessary requirements of OSHA regulations.
- C. At a minimum, Contractor shall have supplies and facilities to:
  - 1. Clean and sanitize minor injuries.
  - 2. Treat and cover minor cuts.
  - 3. Treat minor burns.
  - 4. Reduce swelling due to injuries.
  - 5. Wash chemicals or particles from eyes.
  - 6. Protect personnel administering first aid or CPR, with appropriate PPE such as gloves, mask, breathing barrier.
  - 7. Prevent progression of effects from excessive heat or cold, if identified as a risk.

PRODUCTS

NOT USED

PART 3 EXECUTION

NOT USED

END OF SECTION

applicable UL and ASTM standards.

- C. Water service is necessary for certain Owner facilities and operations. Where indicated in the Work Order, Contractor shall maintain water to those areas and operations at all times, unless otherwise approved in writing.
- D. Contractor shall provide water for Owner facilities and operations when work being performed under their Contract will cause a loss of water, unless otherwise approved in writing.

PART 2 PRODUCTS

NOT USED

PART 3 EXECUTION

NOT USED

END OF SECTION

be supplied with all the necessary fuel. Generators may only be operated with the Contractor present, unless otherwise indicated on the Work Order or approved in writing.

#### 1.5 TEMPORARY HEATING, COOLING AND VENTILATION

- A. Contractor shall provide temporary heating and cooling required by construction activities for curing or drying of completed installations or for protecting installed construction from adverse effects of temperatures and humidity.
- B. Selected equipment shall not have a harmful effect on completed installations or elements being installed.
- C. For temporary use, provide vented, self-contained, liquid-propane-gas or fuel-oil heaters with individual space thermostatic control. Unit shall be listed and labeled for type of fuel being consumed, by a testing agency acceptable to authorities having jurisdiction, and marked for intended use. Use of gasoline-burning space heaters, open-flame heaters, or salamander-type heating units is prohibited.
- D. Provide temporary ventilation required by construction activities for curing or drying of completed installations or for protecting installed construction from adverse effects of high humidity. Coordinate ventilation requirements to produce ambient condition required and minimize energy consumption.
- E. Temporary ventilation shall be provided according to regulatory requirements or manufacturer's recommendations for equipment used during construction and chemical or material application. Where these requirements conflict, the more stringent shall apply.

#### 1.6 TEMPORARY FIRE PROTECTION

- A. Install and maintain temporary fire protection facilities needed to protect against reasonably predictable and controllable fire losses in accordance with National Fire Protection Association 241.
- B. Prohibit smoking in hazardous fire-exposure areas.
- C. Supervise welding operations, combustion-type temporary heating units, and similar sources of fire ignition according to the most recent requirements. Have fire extinguishers on hand for these fire sources.

#### 1.7 TEMPORARY WATER

- A. Contractor shall provide drinking water, sufficient to meet the needs of all workers under their control. Extra water shall be provided during hot weather.
- B. Temporary fixtures, hoses, and controls shall be standard products, meeting



may only be increased, beyond current set points, when indicated by the CWork Order or with written permission.

- F. Ventilation present at existing County facilities shall not be used in such a way that would damage the equipment or facilities or cause improper dispersion of harmful compounds.
- G. Contractor is responsible to determine if the Work in existing facilities requires ventilation in addition to any that may be present or provided by Owner.
- H. Available water in Owner facilities should be used in association with the Work. Whenever possible, plant or service water shall be used in lieu of potable water where it is available.

#### 1.4 TEMPORARY ELECTRICITY AND LIGHTING

- A. The installation and meters for temporary electricity shall remain in place until completion of the Work Order, at which time they shall be removed.
- B. All wiring for electrical power shall be installed and maintained in conformance with the National Electrical Code (NEC), and accepted practices as ordered or approved, and at all points securely fastened in place. Unless otherwise approved, circuits for power and lighting shall be separate.
- C. Continuity of power to and lighting for Owner's facilities must be maintained at all times, unless otherwise indicated in the Work Order or approved in writing.
- D. Where stated in the Work Order, Contractor shall be required to supply temporary electrical power and lighting when the Work will cause power interruptions to critical operations.
- E. Any anticipated electrical power interruptions required by the Work, whether stated in the Work Order or not, shall be included in the Construction Schedule with anticipated length of outage. All outages must be approved in advance.
- F. When the Work performed by Contractor interrupts or causes loss of power to Owner's facilities, Contractor shall provide temporary power and lighting to Owner's facilities until power is restored.
- G. Temporary receptacles, fixtures, and controls shall be standard products, meeting UL standards.
- H. If an area will not be illuminated or if lighting is insufficient to ensure personal safety, that area shall be roped off to prevent access.
- I. Power generators must meet all current emissions and regulatory standards, have sound attenuation or be placed in an area approved by Engineer and Owner, and

**SECTION 01 51 05**  
**TEMPORARY UTILITIES**

PART 1 GENERAL

1.1 SUMMARY

- A. This section includes requirements for Contractor utilities during construction, requirements for Owner's operations during construction, where applicable, and restrictions on the use of Owner's utilities.

1.2 GENERAL

- A. The Work Order will state if Owner utilities are available for Contractor use. If not stated, Contractor shall assume that utilities necessary to perform the Work shall be provided by Contractor.
- B. Unless stated otherwise in the Work Order, where there is more than one Contractor it shall be the obligation and responsibility of each Contractor to provide and maintain temporary utilities necessary for operations under their own Contract, and to make all necessary arrangements therefore, including all required connections, meters, and fees and inspection charges.
- C. Removal of temporary facilities shall be by Contractor that installed or used it.
- D. If, in the opinion of Engineer, the facilities provided are inadequate, Contractor will not be permitted to proceed with any portion of the Work affected thereby until adequate facilities are installed.

1.3 USE OF OWNER UTILITIES

- A. Owner utilities may only be used when indicated by the Work Order or with written permission.
- B. Use of Owner utilities by Contractor for equipment or other items not involved in the Work is prohibited.
- C. Contractor shall monitor and minimize their use of Owner utilities.
- D. Contractor use of Owner utilities shall not interfere in any way with Owner's operations. Contractor shall not disconnect any Owner equipment or facilities without written permission.
- E. Where possible, Contractor shall use the heating and cooling already present at existing facilities for work that requires a minimum or maximum temperature for proper curing, drying or maintenance. Owner heating or cooling equipment usage

**SECTION 01 45 33**  
**CODE REQUIRED SPECIAL INSPECTIONS AND PROCEDURES**

PART 1 GENERAL

1.1 SUMMARY

- A. This section includes references to federal, state and local codes, information on requirements included in codes and associated required special inspection.
  
- B. Related Sections:
  - 1. Section 01 41 05 – Regulatory Requirements
  - 2. Section 01 41 29 – Testing Laboratory Services

1.2 ABBREVIATIONS

- A. IBC – International Building Code

1.3 REQUIRED SPECIAL INSPECTIONS

- A. Concrete, steel, masonry, backfill and other required testing shall be performed by a certified laboratory in accordance with Section 01 45 29 Testing Laboratory Services. Associated special inspections shall be performed in accordance with the Contract Documents and IBC.

PART 2 PRODUCTS

NOT USED

PART 3 EXECUTION

NOT USED

END OF SECTION

coordinating with the Owner to facilitate materials testing.

- B. DPW will require testing of the materials used in roadways and parking areas on County property. At a minimum, Contractor shall submit mix design, stone sieve analysis to Engineer.

#### 1.5 HAZARDOUS MATERIALS TESTING

- A. Where required by the Contract Documents, or when directed by Engineer, Contractor shall perform testing of hazardous materials. Materials shall be sampled and tested according the relevant NYSDEC regulations.
- B. Engineer and Owner shall receive reports of testing results directly from the testing laboratory, in electronic format.
- C. If work was directed by Engineer, but the materials or testing were not indicated in the Contract Documents, Contractor may be entitled to additional compensation according the terms of the Contract. Contractor shall inform Engineer when testing will require additional compensation and, whenever possible, shall provide pricing prior to testing.

#### 1.6 ADDITIONAL TESTING

- A. Additional testing may be required beyond what is specified by the Contract Documents. Whenever directed to do so by Engineer, Contractor shall perform such testing.
- B. Unless the additional testing is required to prove the quality of materials, Contractor may be entitled to additional compensation according the terms of the Contract. Contractor shall inform Engineer when testing will require additional compensation and, whenever possible, shall provide pricing prior to testing.

#### 1.7 CLOSEOUT

- A. Electronic copies of all testing reports must be received as soon as testing is complete. The Contract cannot be closed out if any reports are not submitted. Refer to Section 01 77 19 Closeout Requirements.

### PART 2 PRODUCTS

NOT USED

### PART 3 EXECUTION

NOT USED

END OF SECTION

**SECTION 01 45 29**  
**TESTING LABORATORY SERVICES**

PART 1 GENERAL

1.1 SUMMARY

- A. This section includes requirements related to the use of testing laboratories to be used by Contractor to fulfill testing requirements in the Contract Documents.
- B. Related Sections:
  - 1. Section 01 45 33 – Code-Required Special Inspections and Procedures
  - 2. Section 01 77 19 – Closeout Requirements

1.2 ABBREVIATIONS

- A. DOT – Department of Transportation
- B. DPW – Department of Public Works
- C. NYS - New York State
- D. NYSDEC – New York State Department of Environmental Conservation

1.3 GENERAL

- A. The Owner shall furnish material testing as directed in the Contract Documents. Such tests shall be performed at the Owner's discretion and expense and will be performed by a NYS Certified testing laboratory, selected by Engineer, prior to testing.
- B. Owner reserves the right to independently perform at its own expense, laboratory tests on random samples of material delivered to the Site. Field tests of materials on the job site will be made by Engineer at his discretion.
- C. If materials testing undertaken do not provide satisfactory proof that materials have passed the appropriate laboratory testing, additional field tests of materials may be required. If the Contractor elects to provide additional field testing, at his own expense, the Contractor shall furnish materials and labor required for such field tests and the appropriate laboratory testing shall be performed.

1.4 ROAD MATERIALS TESTING

- A. Testing of materials along roadways will comply with work permits issued by the Agency of jurisdiction. The Owner shall secure and pay for all required testing. The Contractor shall comply with, and bear all the costs associated with

of the Work, shall not preclude rejection at the Site, if the material were found unsuitable.

#### 1.5 STANDARD PRODUCTS

- A. All materials, equipment and accessories shall be new and unused and shall be essentially the standard product of a manufacturer regularly engaged in the production of such material or equipment. See Section 01 61 00 Common Product Requirements. Such items proposed under these conditions must meet all the technical requirements as stated in the Contract Documents.
- B. Any options supplied must meet quality standards and technical requirements as stated in the Contract Documents. See Section 01 62 00 Product Options.

#### PART 2 PRODUCTS

NOT USED

#### PART 3 EXECUTION

NOT USED

END OF SECTION

- C. Where materials are submitted as part of a substitution, in accordance with Section 01 25 13 Product Substitution Procedures, samples or specimens shall be submitted to Engineer in accordance with Section 01 33 10 Submittal Procedures for review to ensure quality.
- D. Contractor shall furnish for review, so as to cause no delay in the Work for any Contract, all required samples. Engineer shall review such samples, with reasonable promptness, for quality standards.
- E. Materials supplied shall be in accordance with reviewed samples. All materials incorporated into the Work shall be equal in quality to the reviewed samples. Should any dispute arise as to the quality or fitness of workmanship, equipment, materials or articles, the decision shall rest with Engineer.
- F. Any material delivered to the Site, whether incorporated in the Work or not, which does not conform to the reviewed sample, will be rejected and shall be promptly removed from the Site and replaced by acceptable materials at Contractor's expense.

#### 1.4 INSPECTION AND TESTING

- A. Owner is permitted to inspect and test materials, or require inspection or testing of proposed materials, for quality, in accordance Section 01 33 10 Submittal Procedures. The need for testing of materials shall be determined by Engineer.
  - 1. Laboratory testing shall be in accordance with Section 01 45 29 Testing Laboratory Services. The entire shipment represented by a given sample or samples may be rejected on the basis of the failure of samples to meet specified test requirements.
  - 2. Code required inspection and testing shall be in accordance with Section 01 45 33 Code-Required Special Inspections and Procedures.
- B. The selection of bureaus, laboratories, and/or agencies for such inspection and testing is subject to the approval of Engineer.
- C. Satisfactory documentary evidence that material has passed the required inspection and testing must be furnished to Engineer prior to its incorporation in the Work.
- D. Any material rejected following inspection or testing must be promptly removed from the Site, whether stored or installed in the work.
- E. The inspection and acceptance of materials and work at the mills, shops, or at any place where material or work is in course of preparation, to facilitate the progress

**SECTION 01 45 05**  
**QUALITY CONTROL**

PART 1 GENERAL

1.1 SUMMARY

- A. This section includes standards for the Project related to quality and quality control.
- B. Related Sections:
  - 1. Section 01 25 13 – Substitution Procedures
  - 2. Section 01 33 10 – Product Submittal Procedures
  - 3. Section 01 42 00 – References
  - 4. Section 01 45 29 – Testing Laboratory Services
  - 5. Section 01 45 33 – Code-Required Special Inspections and Procedures
  - 6. Section 01 61 00 – Common Product Requirements
  - 7. Section 01 62 00 – Product Options

1.2 GENERAL

- A. Wherever in these Specifications any material or apparatus is designated by its trade name, brand or name of manufacturer, it shall be understood that such material or apparatus is specified as a standard of quality required.
- B. The workmanship and materials of all items shall meet industry standard quality requirements and the quality standards of the Contract Documents. If there should be a discrepancy, the highest quality standard shall be maintained unless otherwise directed by Engineer.
- C. Referenced standards, as explained or listed in Section 01 42 00 References, may be used to determine the quality of materials or workmanship.
- D. Material quality shall be maintained from procurement to acceptance of the Project. The quality shall not be diminished by action or neglect.

1.3 MATERIALS REQUIRING SAMPLES

- A. Any material submitted as an 'or equal' in accordance with Section 01 33 10 Submittal Procedures, must be demonstrated to be of equal quality to that of the specified material. Samples may be required.
- B. Where material and quality are not definitely specified, samples or specimens shall be submitted to Engineer in accordance with Section 01 33 10 Submittal Procedures for review, except as otherwise specified for that material.



18. KSF – thousand pounds per square foot
19. KV – kilovolt
20. KVA – kilovolt amperes
21. KW – kilowatt
22. KWH – kilowatt-hour
23. LBF – pounds force
24. LF – lineal feet
25. M – meters
26. MPH – miles per hour
27. MM – millimeter
28. PCF – pounds per cubic foot
29. PSF – pounds per square foot
30. PSI – pounds per square inch
31. PSY – per square yard
32. SF – square foot
33. SY – square yard
34. V - volts

B. Abbreviations may also be listed on the Drawings.

C. Where abbreviations are not spelled out above, they shall mean the recognized shortening of term, given the context. Contractor shall request clarification for any abbreviation that is not listed or the definition known.

PART 2 PRODUCTS

NOT USED

PART 3 EXECUTION

NOT USED

END OF SECTION

15. AWWA - American Water Works Association
16. CIPRA - Cast Iron Pipe Research Association
17. CRSI - Concrete Reinforcing Steel Institute
18. ETL - Electrical Testing Laboratories, Inc.
19. Fed. Spec - Federal Specifications
20. FM - Factory Mutual Association
21. IEEE - Institute of Electrical & Electronic Engineers
22. JIC - Joint Industry Conference
23. NBS - National Bureau of Standards
24. NEMA - National Electrical Manufacturers Association
25. NFPA - National Fire Protection Association
26. NEC - National Electrical Code
27. OSHA - Occupational Safety & Health Administration
28. SMACCNA - Sheetmetal and Air Conditioning Contractors National Association
29. SSPC - Steel Structures Painting Council
30. UL - Underwriters' Laboratories, Inc.
31. USASI - United States of America Standard Institute

- B. Where acronyms are not spelled out above, they shall mean the recognized name of the trade association, standards-producing organization, authorities having jurisdiction or other applicable entity, given the context.

#### 1.5 ABBREVIATIONS

- A. The following are commonly-used abbreviations. Abbreviations may be capitalized or lower case:
1. AC – alternating current or air conditioning
  2. AMP – ampere
  3. C – Celsius
  4. CFM – cubic feet per minute
  5. CM – centimeter
  6. CY – cubic yard
  7. DC – direct current
  8. DEG – degrees
  9. F – Fahrenheit
  10. FPM – feet per minute
  11. FPS – feet per second
  12. FT –feet
  13. GAL – gallons
  14. GPM – gallons per minute
  15. IN – inches
  16. KIP – thousand pounds
  17. KSI – thousand pounds per square inch

they were included in the Contract Documents to the extent referenced. Standards are made part of the Contract Documents by reference. It is Contractor's responsibility to prove compliance with referenced standards.

- C. Publication Dates – Unless otherwise indicated, compliance shall be with the most recent version of the referenced standard, at the date of the Contract.
- D. Conflicts – Where two or more standards are referenced, the most stringent requirement shall be enforced, should there be a conflict in the requirements, unless otherwise specified. If Contractor cannot determine which is more stringent, clarification from Engineer shall be requested.
- E. Minimum or Maximum – Where a minimum or maximum value is stated in a standard, compliance can be achieved if a minimum is equaled or exceeded or a numerical value is at or below a maximum. Where both are stated, compliance must be within both ranges.
- F. Compliance – When requested, Contractor shall furnish evidence satisfactory to Engineer or Owner that materials and methods are in accordance with standards. Such evidence may include the written standard, or applicable parts thereof.
- G. When no reference is made to a code, standard or specification, the Standard Specifications of the ASTM shall govern.

#### 1.4 ACRONYMS

- A. Reference to a technical society, organization, or body may be made in the Specifications by acronyms according to the following list:
  - 1. AAMA - Architectural Aluminum Manufacturers Association
  - 2. AASHO - American Association of State Highway Officials
  - 3. ACI - American Concrete Institute
  - 4. AGA - American Gas Association
  - 5. AGMA - American Gear Manufacturers Association
  - 6. AISC - American Institute of Steel Construction
  - 7. AMCA - Air Moving and Conditioning Association, Inc.
  - 8. ANSI - American National Standards Institute, Inc.
  - 9. ASCE - American Society of Civil Engineers
  - 10. ASHRAE - American Society of Heating, Refrigerating and Air Conditioning Engineers
  - 11. ASTM - American Society of Testing Materials
  - 12. ASME - American Society of Mechanical Engineers
  - 13. AWPA - American Wood Preservers Association
  - 14. AWS - American Welding Society Code

**SECTION 01 42 00**  
**REFERENCES**

I. PART 1 GENERAL

1.1 SUMMARY

- A. This section includes an explanation of references to standards that may be used throughout the Specifications. This section also contains definitions of terms, acronyms and abbreviations used throughout the Contract Documents.

1.2 DEFINITIONS

- A. Approve(d) – Approval action shall be limited to the duties and responsibilities of the party giving approval. Approvals shall be valid only if obtained in writing and shall not apply to that which is the responsibility of Contractor including, without limit, means, methods, techniques, and procedures of construction. Approval shall not relieve Contractor from any Contract requirements.
- B. Directed – This term shall be limited to the authority given by the Contract Documents for the purpose for which it is used. This term shall not be interpreted to extend to the responsibility of any other party or to Contractor’s supervision of construction.
- C. Furnish – Supply and deliver to the Site.
- D. Install – Operations at the Site including, without limitations, unloading, storing, unpacking, assembling, erecting, placing, anchoring, applying, working to dimension, finishing, curing, protecting, cleaning, and similar operations.
- E. Provide – Furnish and install, complete and ready or intended use.
- F. Testing Agency – An independent entity engaged, through contract or other procurement, to perform specific inspections or tests, and to report on and interpret results of the inspections or tests, where applicable.

1.3 STANDARDS

- A. General – Contractor, or those under the control of Contractor, shall be familiar with the applicable aspects of the specified standard where it applies to the Work. Contractor, or those under the control of Contractor, must obtain reference standards from publishing sources for any standard with which Contractor is unfamiliar.
- B. Applicability - Unless the Contract Documents include more stringent requirements, applicable industry standards have the same force and effect as if

- B. Where stormwater discharges into a municipal separate storm sewer system (MS4), coordination with the owner of the MS4 will be required. Contractor shall comply with all inspection requirements of the MS4.

1.6 POST-CONSTRUCTION FACILITIES

- A. Contractor shall install all post-construction stormwater facilities as required by the SWPPP.

PART 2 PRODUCTS

NOT USED

PART 3 EXECUTION

NOT USED

END OF SECTION

4. Uncontaminated infiltration and inflow or leakage from raw water conveyance systems.
5. Routine external building wash down and vehicle washing which does not use detergents or other compounds; and pavement wash waters where spills or leaks of toxic or hazardous materials, other than minor and routine releases from motor vehicles, have not occurred (unless such material has been removed) and where detergents are not used.
6. Air conditioning and steam condensate.
7. Springs; uncontaminated groundwater; and foundation or footing drains where flows are not contaminated with process materials such as solvents.
8. Waters to which other components have not been added that are used to control dust in accordance with the SWPPP.
9. Uncontaminated discharges from construction site de-watering operations.

E. Prohibited Discharges include:

1. Wastewater from washout of concrete.
2. Wastewater from washout and cleanout of stucco, paint, form release oils, curing compounds and other construction materials.
3. Fuels, oils, or other pollutants used in vehicle and equipment operation and maintenance.
4. Soaps or solvents used in vehicle and equipment washing.
5. Toxic or hazardous substances from a spill or other release.
6. Discharges after final stabilization.
7. Discharges mixed with sources of non-stormwater other than those addressed in the SWPPP.
8. Discharges required to obtain an individual SPDES permit.
9. Discharges that adversely affect an endangered or threatened species.

## 1.5 SWPPP REQUIREMENTS

- A. Contractor shall implement all components of the SWPPP as directed.

stormwater collection or conveyance systems.

1. During dry weather, stormwater collection grates shall be covered when Contractor is working in the area that drains to that grate, regardless of whether or not the Contractor is performing activities that disturb soil, unless a SWPPP has been written that states otherwise.
  2. Unless otherwise stated in a SWPPP, during wet weather events Contractor shall divert flow around possible sources of contamination. Stormwater collection grates shall be covered only when there is no other way to prevent soil, chemicals or other materials from be washed down during the wet weather event. Contractor shall then collect or otherwise treat or filter contaminated run-off.
  3. At the end of each work day, all drainage areas shall be cleaned, and any covered grates shall be uncovered, unless otherwise indicated in a SWPPP. Dust and soil transfer into stormwater systems shall be avoided. Refer to Section 01 41 27 Dust Control for information on minimizing dust transfer.
- D. Contractor shall implement all necessary provisions to prevent pollution of adjacent sites or natural resources, due to stormwater runoff.

#### 1.4 PERMIT REQUIREMENTS

- A. If a Work Order is covered by the SPDES General Permit for Stormwater Discharges from Construction Activity, effluent limitations contained in that permit must be attained through the use of best practices contained in the SWPPP.
- B. Contractor shall not begin construction activities until written authorization is received by Owner or Engineer and given to Contractor.
- C. This permit covers stormwater discharges; including stormwater runoff, snowmelt runoff, and surface runoff and drainage from construction activities.
- D. Non-stormwater discharges must be identified in the SWPPP. Identified non-stormwater discharges authorized by this permit, provided that an effective plan is implemented to minimize discharge of pollutants from these sources, include:
  1. Discharges from firefighting activities (during unplanned emergencies only); fire hydrant flushings; and testing of firefighting equipment, provided that such equipment is for water only fire suppression.
  2. Potable water sources including waterline flushings.
  3. Irrigation drainage; and lawn watering.

**SECTION 01 41 28**  
**STORMWATER POLLUTION PREVENTION**

PART 1 GENERAL

1.1 SUMMARY

- A. This section includes protections for preventing pollution of neighboring sites, stormwater systems, or adjacent natural resources due to construction activity. This section also includes permit requirements related to the SPDES General Permit for Stormwater Discharges from Construction Activity.
- B. Related Sections:
  - 1. Section 01 41 05 – Regulatory Requirements
  - 2. Section 01 41 27 – Dust Control

1.2 DEFINITIONS

- A. State Pollution Discharge Elimination System (SPDES) – Requirement to permit discharges.
- B. General Permit for Construction – Shortened version of the SPDES General Permit for Stormwater Discharges from Construction Activity; the permit that controls discharges from construction activity disturbing one acre or more or where there is a potential for contribution to a violation of a water quality standard.
- C. New York State Department of Environmental Conservation (NYSDEC) – Permit holder for the SPDES General Permit for Construction.
- D. Stormwater Pollution Prevention Plan (SWPPP) – Plan that lists non-stormwater discharges and describes practices that will be in place to meet discharge limitations.

1.3 GENERAL

- A. Contractor shall comply with all applicable plans and permits. Refer to Section 01 41 05 Regulatory Requirements.
- B. Contractor shall provide and maintain containment for all compounds that could be transported into a stormwater system during a wet weather event. These compounds include, without limitation, fill, soil, stone, paints, coatings, and cleaning compounds.
- C. Contractor shall implement all necessary provisions to prevent pollution of



3. Any damage caused by dust from Contractor's operation shall be remedied at his expense.
- B. Contractor shall avoid driving any vehicle on materials that could become easily airborne until water can be applied to the materials.
- C. Dust generating work shall be restricted when conditions will cause excessive amounts of dust to become airborne.

END OF SECTION

- E. At the end of each work day, the Site shall be cleaned to avoid transfer of materials outside the work area.

### 1.3 NEW YORK STATE LABOR LAW REQUIREMENT

- A. If, in carrying out this Contract, a harmful dust hazard is created for which appliances or methods for the elimination of harmful dust have been approved by the Board of Standards and Appeals, then the Contractor agrees to install, maintain and effectively operate such appliances and methods during the life of this Contract; and in case of failure of compliance of Contractor as provided by Section 222a of the Labor Law, its Contract shall be void.

### 1.4 DUST CONTROL MATERIALS

- A. The use of any petroleum products or the use of calcium chloride for dust control is strictly prohibited.
- B. Water should be used, whenever possible, for dust control.
- C. Any other chemicals or liquids, other than pure water, proposed for use in controlling dust must be submitted and approved. Refer to Section 01 33 10 Submittal Procedures.
- D. Coverings for soil piles or other loose materials shall be solid sheet materials or a tight enough weave to prevent dry materials from become airborne in windy conditions.
- E. Coverings for soil piles or other loose materials must be weighed down to the extent that the covering is not lifted in strong winds.

## PART 2 PRODUCTS

NOT USED

## PART 3 EXECUTION

### 3.1 DUST CONTROL

- A. When directed by Engineer, the contractor shall apply water where directed, in such quantities and at such frequencies as may be required, to control dust and prevent it from becoming a nuisance to the surrounding area.
  - 1. All roads must be maintained dust free at all times.
  - 2. Daily cleaning will be required.

**SECTION 01 41 27  
DUST CONTROL**

PART 1 GENERAL

1.1 SUMMARY

- A. This section includes requirements for controlling dust from construction activities including grinding and earthmoving.
- B. Related Sections:
  - 1. Section 01 33 10 – Submittal Procedures
  - 2. Section 01 41 05 – Regulatory Requirements
  - 3. Section 01 41 28 – Stormwater Pollution Prevention

1.2 GENERAL

- A. Contractor shall comply with all applicable plans and permits. Refer to Section 01 41 05 Regulatory Requirements.
- B. Contractor shall comply with all applicable regulations and standards related to silica dust.
- C. Contractor shall implement all necessary provisions to prevent particles from becoming airborne.
  - 1. Contractor shall provide water for spraying down materials that could contain or become airborne particles.
  - 2. Outdoor dust generating work shall be avoided on high wind days.
  - 3. Loose materials, such as soil, shall be covered when not in use.
- D. Contractor shall implement all necessary provisions to prevent dust, soil or particle transfer from the construction site to adjacent areas.
  - 1. Provide barrier protection at the entrance to the construction area.
  - 2. Wash down vehicles to remove dust before leaving the job site. When washing down vehicles, avoid stormwater system pollution. See Section 01 41 28 Stormwater Pollution Prevention for information on stormwater system protections.
  - 3. Contain demolished materials with covering or netting when necessary to prevent dust generation.

PART 3 EXECUTION

3.1 PERMIT CLOSE-OUT

- A. All applicable permit requirements must be completed prior to project closeout. Refer to Section 01 77 19 Closeout Requirements for specific information related to the Work.
  
- B. Stormwater - Where required by Section 01 41 28 Stormwater Pollution Prevention, permanent structures may be required to control, treat or capture storm water. Contractor shall meet all requirements prior to Substantial Completion.

END OF SECTION

6. Contractor and Owner signatures.
- C. Agencies of jurisdiction may restrict hours or dates of the work.
  - D. NYS Thruway - For work that crosses or encroaches on land owned by the NYS Thruway Authority, Contractor will be required to submit a Thruway Permit Application in association with that submitted by Owner. Thruway Permit Applications must include the following:
    1. Completed application form with work schedule indicated.
    2. Required work permit fee, if required.
    3. Insurance documents that include:
      - a. Acord – Certificate of Liability Insurance with the NYS Thruway Authority as an additional insured and shown as the certificate holder.
      - b. Separate Worker’s Compensation Form – One of the following forms: U-26.3, C 105.2 or GSI-105/SI-12.
      - c. Disability Insurance Form – One of the following DB-120.1, DB-155, or CE-200.
      - d. Drawing(s) that show the crossing or encroachment on NYS Thruway property.
      - e. Aerial photo or other map indication of the location of the Work.

#### 1.8 UTILITIES

- A. Contractor shall comply with New York State General Business Law Section 764 Duties of Excavators and all requirements referenced within.
- B. Contractor shall contact UDig NY at [udigny.org](http://udigny.org) or 811 prior to any excavation. Contractor shall be responsible for obtaining any permits required for utility protection.
- C. Contract shall obtain necessary permits and requirements from the Erie County Water Authority or the municipality that owns the water system before using any hydrants.

## PART 2 PRODUCTS

NOT USED

19. Electrical power transmission and distribution including, without limitation, medical services, enclosed spaces, PPE, portable ladders and platforms, power equipment, live-line tools, materials handling and storage, working near energized parts, de-energizing lines and equipment, grounding protection, testing, overhead lines, underground installations, and substations.

20. Rollover protective structures and overhead protection.

21. Stairways and ladders.

22. Toxic and hazardous substances.

23. Standard interpretations.

B. Contractor must explicitly state how they will comply with OSHA's requirements. Refer to Section 01 35 28 Contractor's Health and Safety Plan.

C. Contractor must identify confined spaces and comply with rules and regulations related to confined space entry. Refer to Section 01 35 26.23 Confined Space Entry Plan.

D. Contractor must provide safety data sheets for hazardous chemicals used in the Work. Refer to Section 01 35 43.13 Environmental Procedures for Hazardous Materials.

#### 1.7 ROAD PERMITS

A. Work along and under roads shall be performed in compliance with work permits issued by the Agency of jurisdiction. Contractor shall secure and pay for all required permits. Contractor shall comply with, and bear all the costs associated with, requirements of the permit.

B. Applications for work permits along roadways may differ from jurisdiction to jurisdiction, and from municipal level (state, county, or local), but permit applications will generally require:

1. Application form.
2. Application fee.
3. Insurance certificates.
4. Traffic control plan.
5. Work Schedule.

2. Occupational health and environmental concerns including, without limitation, sanitation, noise exposure, radiation, ventilation, communication, and hazardous chemicals and waste.
3. Personal protective and life saving equipment including, without limitation, criteria for PPE, foot protection, electrical protective equipment, head protection, hearing protection, eye and face protection, respiratory protection, safety belts, safety nets, and working over or near water.
4. Fire protection and prevention including, without limitation, fire protection, fire prevention, flammable liquids, and temporary heating devices.
5. Accident prevention signs and tags.
6. Materials handling, storage, use and disposal.
7. Hand and power tools.
8. Welding and cutting.
9. Electrical including, without limitation, wiring design and protection; wiring methods, components, and equipment; specific purpose equipment and installations; hazardous locations; lockout and tagging of circuits; environmental deterioration of equipment; and batteries and battery charging.
10. Scaffolds and fall protection.
11. Helicopters, hoists, elevators and conveyors.
12. Motor vehicles, mechanized equipment and marine operations.
13. Excavations including, without limitation, specific excavation requirements, requirements for protective systems, soil classification, sloping and benching, shoring for trenches, and selection of protective systems.
14. Concrete and masonry construction including, without limitation, requirements for equipment and tools, cast-in-place concrete, precast concrete, lift slab operations, and masonry construction.
15. Steel erection.
16. Underground construction, caissons, cofferdams, and compressed air.
17. Demolition.
18. Blasting and the use of explosives.

- b. Prior to commencement of stream crossing operations, Contractor shall submit construction drawings of each stream crossing to Engineer for his approval in accordance with Section 01 33 10 Submittal Procedures. The drawings shall show the following information:
  - i Proposed methods of construction
  - ii Details of sequence of construction
  - iii Proposed methods for maintaining flows during construction operations
  - iv Proposed methods for preventing damage to property in the event of sudden or heavy storms
- c. Contractor shall be responsible for the preservation of all stream banks within and adjacent to the limits of work.
- d. Any stream bank disturbed by Contractor's operations will be rip-rapped or otherwise protected at Contractor's expense as ordered by Engineer.
- e. When the top of excavation is within ten (10) feet of the top of any stream bank, Contractor shall provide protection for the stream bank at his own expense and as approved by Engineer.
- f. Additionally, for those streams classified C and D, which will be crossed by a sewer pipeline and/or the banks will be disturbed during the course of construction:
  - i Prior to commencing work on the stream crossing and prior to commencing work on the banks of the stream, Contractor shall contact the legal Regional Supervisor of Regulation and inform him of the impending work.
  - ii Contractor will be advised by the local Regional Supervisor of Regulation of the procedures and conditions required to be following on making the stream crossing and/or working on the banks of the stream.

## 1.6 OSHA REQUIREMENTS

- A. OSHA administers and enforces regulations and requirements related to construction health and safety, generally included in 29 CFR 1926 and 29 CFR 1910. Contractor must comply with the most recent regulations. OSHA Requirements include, without limitation, the following provisions:
  - 1. General provisions including, without limitation, training, reporting of injuries, medical attention, fire prevention, housekeeping, personal protective equipment (PPE), employee records, and emergency action plans.



to 12" lower than the toe of the channel bank, to concentrate the flow water.)

5. Where work necessitates disturbing banks, they shall be returned to original condition, or as shown on the Drawings. All tree and brush removal shall be kept to a minimum.
6. Any dike or cofferdam required to facilitate construction shall be erected in such a manner that stream flow will not be sufficiently reduced to endanger fish life downstream and such dike or cofferdam shall be erected of materials that will not contribute substantially to the turbidity or siltation of the stream.
7. During the project, care shall be taken to prevent or reduce to a minimum any damage to the stream from pollution by debris, sediment, of other material or from the manipulation of equipment and/or materials in or near such streams. Water that has been used for washing or processing or that contains oils and sediments that will reduce the quality of water in the stream shall not be directly returned to the stream. Such waters will be diverted through a settling basin, or filter before going into the stream.
8. If water is taken from a stream for construction purposes and an impounding structure is necessary, such structure shall be erected in a manner causing the least possible disturbance to the stream.

C. For work involving stream crossings:

1. A stream crossing permit may be required:
  - a. Owner has made application for necessary stream crossing permits required for this Contract. These permits will be issued to Contractor upon submission of satisfactory methods and timetable for construction of the stream crossings, in accordance with Section 01 33 10 Submittal Procedures, and to insure compliance with the above standards.
  - b. For stream crossings not requiring permits, compliance with the above standards, to the extent applicable, will be required for stream crossings and work adjacent to water bodies in this Contract.
2. The following restrictions shall apply to all stream crossings:
  - a. Prior to any stream channel relocation, or other work that may affect the character or location of trout or other game fish waters, Contractor will contact the NYSDEC to determine whether they wish to remove the fish or perform any other work. If any fish salvage or other protective measures are deemed necessary, Contractor will cooperate with and coordinate his work with the NYSDEC.

SECTION 02100 – PART I – CLEARING AND GRUBBING

PART I – GENERAL

1.01 SCOPE OF WORK

A. The Contractor shall clear and grub in the areas required for construction and remove all debris resulting from the work. The Contractor shall confine his operations within the limits indicated on the Plans or Work Order descriptions, including limits of easement lines and right-of-way, and shall not enter any area outside these limits without prior written consent of the Owner or Engineer.

B. Existing features, trees and vegetation to remain shall be protected, and if damaged or destroyed, shall be repaired or replaced in kind at the Contractor's expense.

PART II – PRODUCTS – NOT APPLICABLE

PART III – EXECUTION

3.01 CLEARING AND GRUBBING

A. Except as otherwise directed, cut, grub, remove and dispose of all trees, stumps, brush, shrubs, roots and any other objectionable material within the limits defined on the Drawings. All stumps, brush and roots shall be grubbed and removed from areas to be occupied by buildings, structures, roads, pipelines and any other areas if designated by the Engineer.

B. After interfering vegetation has been removed, the Contractor shall strip any and all topsoil from the area to be excavated and stockpile it for future use.

C. Trees and foliage designated by the Engineer to remain shall be protected from damage by erecting suitable barriers, or by other approved means. Clearing operations shall be conducted in the manner to prevent falling trees from damaging trees designated to remain or other existing features.

D. Where it is necessary to cut branches of trees which are to remain, the cut shall be made flush with trunk or larger branch, with care being taken to prevent tearing and bark beyond the cut. An acceptable commercial tree paint shall then be applied over cut or damaged areas.

E. Areas outside the limits of clearing shall be protected and equipment or materials shall not be stored or allowed to damage these areas.

F. Stumps, trees, limbs or brush shall not be buried in any fills or embankments or disposed of in any stream corridor, wetland or any surface.

SECTION 02100 – PART III

3.02 DISPOSAL OF MATERIALS

A. All tree trunks, limbs, roots, stumps, brush, foliage and other vegetation shall be removed and promptly disposed of by the Contractor off the project site, in a manner satisfactory to the Engineer.

B. Burning shall not be permitted as a means of disposal. Other means such as chipping, burying (in approved areas), and salvage of marketable lumber shall be employed.

C. Dumping of spoil material into any stream corridor, wetland, flood plain or surface water is prohibited. The Contractor shall dispose of such material strictly adhering to all applicable Federal, State, and Local Laws and Regulations.

D. The Contractors are advised that all existing sanitary sewer pipe removed during the construction of this contract must be disposed of at any approved NYSDEC landfill site. Further that any contaminated earth and/or bedding material around the existing sanitary sewer must also be disposed of in a similar manner.

## SECTION 02150 – SITE DEWATERING SYSTEMS

### PART I – GENERAL

#### 1.01 SCOPE OF WORK

A. The Contractor shall furnish all labor, materials, and equipment required to successfully dewater the project site to allow for the construction of the scheduled improvements.

### PART II – PRODUCTS

#### 2.01 EQUIPMENT

The Contractor shall provide all pumping equipment, pipe, stone, fabric, machinery and other necessary items required to operate and maintain the dewatering system throughout the construction of the project.

### PART III – EXECUTION

#### 3.01 PREPARATION

A. The Contractor shall employ the proper procedures needed for the dewatering of the excavations and/or project site based on review of on-site conditions. Where available, subsurface investigation reports will be provided for the Contractor's information.

B. The Contractor shall investigate and become familiar with all Local, State and Federal Regulations which govern in this matter. The Contractor shall apply for and obtain the necessary discharge permits for the dewatering system at the Contractor's own expense. Determining permit requirements shall be the responsibility of the Contractor.

C. The Contractor shall examine adjacent structures and utilities, both existing and under construction, for possible settlement, movement or other adverse effects resulting from dewatering methods or water removal. Take necessary precautionary steps to protect such structures and utilities.

D. Should the drawdown of groundwater levels by removal or dewatering systems critically reduce or disrupt public or private water supplies, the Contractor shall be prepared to:

1. Provide at his expense adequate potable water to the Owners or users of the affected water supplies under groundwater levels have recovered, so as to sufficiently restore those deficient water supplies.

SECTION 02150 – PART III

2. Provide to the Engineer documentation to confirm that temporary water supplies meet the requirements of Local, State and Federal regulatory agencies.

3.02 REMOVAL OF WATER

A. The Contractor shall assume total responsibility for site, surface and subsurface drainage. Maintain such drainage as specified herein during the life of the contract.

B. The Contractor shall supply all supervision, labor, material, equipment, including standby equipment, necessary to maintain a dry excavation as may be needed to construct the project.

C. The Contractor shall maintain groundwater in or below the bearing strata at a safe level at all times by methods which prevent loss of fines, which preserves the undisturbed state of subgrade soils and which sufficiently lowers the groundwater level in permeable strata at or below excavation and fill levels such that blowing or unstable conditions do not develop in the bottom or sides of excavation or fill areas.

D. The Contractor shall protect all adjacent structures, existing and under construction, from settlement, floatation, damage or other adverse effects resulting from water removal or dewatering methods.

E. The Contractor shall install measures as required to create and maintain a dry excavation and a groundwater level at a minimum of 2 feet below excavation subgrades.

1. As part of any dewatering system, observation wells or piezometers shall be provided and installed, as required, to effectively and efficiently monitor drawdown to required levels.

F. The Contractor shall direct all discharged water removed from the site to a sedimentation pond with an outfall to natural water courses, storm drains or channels.

1. Large quantities of water shall not be discharged as overland flows. Overland flow is not permitted onto private property.

2. No unpolluted water shall be discharged to sanitary sewers.

3. Wastewater shall be disposed of in a manner satisfactory to the local Public Health Officer.

G. The dewatering operations shall cease when all foundations, structures, pipe installations and other excavating areas have been properly backfilled and compacted, and are safe from damage, floatation, settlement and displacement.

SECTION 02150 – PART III

H. If well points or wells are used, they shall be adequately spaced to provide the necessary dewatering and shall be sandpacked and/or utilize other means to prevent pumping of fine sands or silts from the subsurface. A continual check by the Contractor shall be maintained to ensure that subsurface soil is not being removed by the dewatering operation.

I. Construction of temporary facilities to dispose of water shall be incidental to the construction and shall be performed at no additional cost to the Owner.

J. Permanent piping systems shall not be incorporated in the dewatering system.

3.03 MAINTENANCE OF SYSTEM

A. The Contractor shall operate and maintain dewatering and removal operations on a 24-hour basis for the time required to complete that portion of the work which requires dewatering prior to its construction and which requires protection from floatation or displacement of such work until proper backfilling and compaction is completed.

3.04 REMOVAL OF DEWATERING SYSTEM

A. After groundwater levels have returned to elevations appropriate for conditions and time of year, without causing damage to the work, the Contractor shall remove all dewatering equipment and related equipment from the site and restore site to original conditions or rehabilitate site to meet requirements of Contract Documents.

## SECTION 02200 – EARTHWORK

### PART I – GENERAL

#### 1.01 SCOPE OF WORK

##### A. General

The Contractor shall furnish all labor, materials, tools, equipment, services and incidentals necessary to perform all earth and rock excavation, ground water control, sheeting and shoring, backfilling, compacting and grading for all structures, pipelines and utilities.

##### B. Site Grading

1. The Contractor shall perform all grading work indicated on the Plans or specified. The surface area of the site, including all excavations, cuts, fills and embankments, shall be finished to the lines, grades, and cross-sections shown on the Plans, and shall be cleaned of all loose material.

2. Erosion control procedures, inclusive of mulching, shall be utilized along the right-of-way and access roads. Erosion control shall occur as required and immediately following (weather permitting) completion of sewer construction.

##### C. Site Investigation

1. It shall be the Contractor's responsibility to investigate the actual conditions existing at the site. No extras will be allowed for any excavations, imported fill, disposal of excess excavated material or material unsuitable for grading, nor for any conditions which would have been foreseen by thorough examination of the site, the Plans and Specifications.

##### D. Excavating and Backfilling

1. The Contractor shall perform all excavation for the installation of the work under his Contract including all trenching, backfilling, grading and embankment work to the lines and grades indicated on the Plans, herein specified, or ordered by the Engineer. The work shall include but not be limited to excavation for the structures, footings, manholes and chambers, pipes, ducts, roadways, pavements and ditches; all bedding, backfilling and fill materials; embankment construction, protection of excavations, structures and utilities above and below grade requiring sheeting, shoring and bracing; handling of water, including pumping and bailing; dewatering as required; restriction of surfaces; filling unauthorized excavations, disposal of surplus materials and all incidental work.

2. The Contractor shall assume the risk of encountering and shall include the cost of (unless specifically included in a bid item) removal of quicksand, hardpan,

## SECTION 02200 – PART I

boulders, rock, clay, rubbish, unforeseen obstacles, underground conduits, gas pipe, drain tile, trees, roots, timber, concrete slabs, or masonry structures, pavements and sidewalks and the delay or damage occasioned by same, whether or not these obstacles are shown on the Contract Drawings. No claim beyond the contract price of the work will be allowed due to the character of the ground in which the excavation is made.

3. At intersections and elsewhere, where there are existing services, such as water mains, gas lines, electric conduits, etc., the Contractor shall uncover said pipes and structures a sufficient time in advance of the construction of the proposed work to definitely determine the liens and elevation of the existing structures with reference to the new work so that, if required, change in line and/or grade can be made in the new work. The Contractor shall be responsible to advise all utilities and agencies of the extent, scope and schedule of his operation.

4. Where waterlines are close (10 feet or less) to proposed sewers, the Contractor shall comply with the provisions of the Ten State Standards, (2014 Edition or latest) as stipulated in the section "Relation to Water Mains".

5. The Contractor shall be responsible at all times for carrying out excavation and trenching work in a safe and prudent manner to protect the workmen and public from unreasonable hazard, and conform to the Williams-Steiger Occupational Safety and Health Act of 1970 (as amended), Public Law 91596, Part 1518 Safety and Health Regulation for Construction, and/or the New York Department of labor Industrial Code Rules, whichever is stricter. All applicable local, State and/or Federal requirements shall be observed, and necessary permits acquired by the Contractor.

### E. Definitions

1. The term "unclassified excavation" as herein defined shall be construed to mean all classes of material, wet or dry, and shall include so-called muck, hardpan, soft shale or slate, loose disintegrated or decomposed ledge rock, old macadam, topsoil, sod, masonry, all material requiring drilling and blasting, sledging, barring or wedging for removal from their original beds and specifically includes all ledge or bed rock and boulders.

### 1.02 RELATED WORK SPECIFIED ELSEWHERE

- A. Clearing and Grubbing as specified in Section 02100.
- B. Sheeting, shoring and bracing as specified in Section 02250.
- C. Site drainage and dewatering as specified in Section 02150.



SECTION 02200 – PART I

1.03 PRODUCT DELIVERY, STORAGE AND HANDLING

A. Excavated Material

1. Excavated materials to be reused shall be stored in locations that will not interfere with construction operations.
2. Unsuitable and surplus excavated material and debris shall be disposed of by the Contractor at his own expense outside the limits of the project site. Disposal shall be in accordance with Section 02100, Clearing and Grubbing, 3.02.

1.04 JOB CONDITIONS

A. Protection of Property

1. Necessary arrangements shall be made by the Contractor with all persons, firms and corporations owning or using any poles, pipes, tracks or conduits, etc., affected by the construction included under this Contract to maintain and protect such facilities during construction. The cost of any such protection shall be paid by the Contractor.
2. Excavated materials shall be deposited only in designated areas. The Contractor shall avoid depositing excavated material on pavements, sidewalks or grass plots, except with written authorization, and then only when adequate temporary provisions have been made for passage and protection of pedestrians and vehicles. Adequate bridging and planked crossings must be provided and maintained across all open trenches for pedestrians and vehicles.
3. The Contractor shall shore up or otherwise protect all fences, buildings, walls, walks, curbs or other property adjacent to any excavation which might be disturbed during the progress of the work. The Contractor shall be liable for any damage which may result to neighboring property from excavation, backfill or grading operations.
4. In situations where the Contractor is connecting a new pipelines to an existing structure or existing pipeline, the Contractor shall install and maintain a temporary plug in either the new or existing pipeline at the point of connection. The purpose of the plug is to assure that no water or construction sediment or debris will enter the system. The plug shall remain in place for the entire construction period. Upon acceptance of the new pipeline by the Owner, the Contractor shall make the necessary arrangements to remove the plug.

SECTION 02200 – PART II

PART II – PRODUCTS

2.01 MATERIALS

A. Earth Fill

1. Earth fill shall be fine loose material from the excavations, free from trash, frozen lumps, organic substances, rocks over 4 inches in diameter, or other materials which cannot be properly compacted. Physical properties shall be such that it can be readily spread and compacted.

B. Select Granular Backfill

1. For Pipe Lines, Chambers and Manholes

a. Select granular backfill shall be run of crusher stone or run of crusher gravel meeting the requirements of the New York State Department of Transportation (NYSDOT) Standard Specifications (latest edition), (NYSDOT Item #304.12 – Type 2 Subbase), and meet the following limits:

<u>Sieve Size</u>	<u>Percent Passing by Weight</u>
2"	100%
1/4"	25 – 60%
No. 40	5 – 40%
No. 200	0 – 10%

2. For Structures

a. Select granular backfill shall be run-of-bank gravel or well graded crushed stone material acceptable to the Engineer. Maximum size shall not exceed 2 inches in any direction.

C. Granular Foundation Material

1. Granular foundation material shall be well graded crushed stone backfill as approved by the Engineer. The crushed stone shall have a maximum size of 4 inches in any direction unless otherwise indicated on the Plans or specified by the Engineer.

D. Pipe Bedding Materials

1. Unless otherwise indicated on the Drawings, or as directed in the field by the Engineer, pipe bedding material shall be a NYSDOT Section 703-02, No. 1 Crushed stone which satisfies the following gradation limits as approved by the Engineer.

SECTION 02200 – PART II

<u>Sieve Size</u>	<u>Percent Passing by Weight</u>
1"	100%
½"	90 – 100%
¼"	0 – 15%

2. Crushed stone for bedding pipe shall meet all the requirements of NYSDOT Standard Specifications (Latest Edition), Section 703-02 and shall consist of clean, durable, sharp angled fragments of rock of uniform quality. Round No. 1 stone will not be accepted for use as a pipe bedding material. Crushed stone for bedding pipe shall be obtained from sources conforming to the requirements of the NYSDOT as to sampling, testing methods, quarry reports and any other required procedures.

E. Structural Base (Undercut Material & Fabric)

1. Unless otherwise indicated on the drawings, or as directed in the field by the Engineer, the structural base of undercut material shall be a crushed stone, satisfying the gradation outlined in NYSDOT Section 703-02, Table 703-4, Size Designation 4 or a crushed stone used in conjunction with a geotextile fabric satisfying the requirements of NYSDOT, Section 304.3.03, Type 1. A further description of the allowed material properties and/or gradation limits for the aggregate and fabric is as follows:

a. Crushed Stone, NYSDOT, Section 703-02, Size Designation 4

<u>Sieve Size</u>	<u>Percent Passing by Weight</u>
4"	100%
3"	90 – 100%
2"	0.15%

b. Geotextile Fabric

i. The geotextile fabric shall be of the type appropriate for the intended use as shown on the plans or as ordered by the Engineer. The geotextile fabric shall be a woven or non-woven type, as specified, manufactured by Mirafi, Amoco or equal. The contractor's shop submittal for this item shall contain an original certification from the manufacturer, which indicates the model number of the geotextile fabric and their proposed recommended for the fabric's use in this situation.

## SECTION 02200 – PART III

### 3.01 EXCAVATION

#### A. General Requirements

1. The Contractor shall scrape and stockpile top soil from the work area prior to the start of excavation. The stockpile material shall be properly staked with hay bales or fabric to control erosion/loss of soil. All topsoil shall be respread in the construction area during final restoration.

2. Excavation shall be made to such widths as will give suitable room for construction of the structures, for forms, sheeting, bracing and supporting, pumping and draining; and the bottom of the excavations shall be rendered firm and dry and in all respects acceptable to the Engineer.

3. Excavation and dewatering shall be accomplished by methods which preserve the undisturbed state of subgrade soils. Subgrade soils which become soft, loose, “quick”, or otherwise unsatisfactory for support of structures as a result of inadequate excavation, dewatering or other construction methods shall be removed and replaced by concrete or granular fill as required by the Engineer at the Contractor’s expense.

#### B. Excavation

1. Excavation shall be carried to the depth and dimensions necessary for the proper installation of all work as detailed on the Contract Drawings. Unless specifically directed by the Engineer, excavation shall not be made below the elevations indicated on the Contract Drawings. Where any unauthorized excavation is made below the grades indicated, the excavations shall be restored to the proper elevation with compacted, well graded granular foundation material, or, if under footings, the heights of the walls or footings shall be increased at no additional expense to the Owner. In any event, the operations necessary to correct an excess of excavation shall meet with the consent of the Engineer. If deemed necessary, concrete instead of granular fill shall be used to correct unauthorized excavations.

2. Per the direction of the Engineer, the Contractor may be required to undercut the excavation to establish a sound base for the pipe and pipe bedding material. In such instances, the contractor will excavate an additional 24 inches (minimum) below the invert of the pipe or as ordered by the Engineer. The Contractor shall then proceed to install the geotextile fabric along the trench bottom. The fabric should be placed loosely with no wrinkles or folds. Successive sheets of fabric should be overlapping the downstream sheet. Once the fabric is in place, the Contractor shall then backfill the undercut area using the structural base granular fill material to the bottom elevation of the pipe bedding material.

SECTION 02200 – PART III

C. Trench Excavation

1. The Contractor shall excavate trenches to the depth necessary for proper placing of pipe. The trench width at the crown of the pipe shall be kept to a minimum, allowing only the space necessary for proper pipe laying.

2. The trench width will depend upon the depth, nature of material excavated, and method by which excavation is accomplished. In any case, sufficient clearance around the pipe shall be provided to properly lay the pipe, make the joint, and install and compact the backfill. The minimum width of trench shall be one pipe diameter plus at least 12 inch clearance on each side of pipe.

3. Above the crown of the pipe, the trench shall be kept as narrow as practical, with sides as nearly vertical as consistent with good workmanship and safety. The trench dimensions and procedure of trench excavation shall be subject to the acceptance of the Engineer.

4. The trench shall be opened a minimum distance ahead of pipe laying as accepted by the Engineer.

5. The trench shall be braced, sheeted and dewatered, as required, to provide safe, firm and dry conditions.

6. The Contractor shall exercise care to avoid damage to existing structures, utilities, and pipes in the performance of the work. In locations where the excavation is carried beneath or adjacent to existing structures, utilities, or pipes, the Contractor shall furnish and install sheeting and bracing as necessary to support such structures, utilities or pipes in their original position, and shall be responsible for any damage caused to such utilities by this work.

7. On all excavations greater than 4'-0" in depth, the Contractor shall utilize a trench sheeting box or standard sheeting, shoring and bracing. The Contractor shall secure the services of a Professional Engineer licensed in the State of New York who shall observe his construction operation and design the proper method of sheeting, shoring, and bracing to be utilized during construction.

8. On all excavations less than 4'-0" in depth, the Contractor shall secure the services of a Professional Engineer licensed in the State of New York who shall analyze the existing conditions with the contractor's method of construction and advise him of the proper method to support his trenching operation.

## SECTION 02200 – PART III

### 3.03 BACKFILLING

#### A. Requirements

1. All trenches and excavation shall be backfilled to the original surface of the ground or to such other grades as may be shown on the plans or directed.
2. The method and degree of compacting backfill will be governed by the type of material and the extent to which any subsequent settlement can be permitted.

#### B. Placement of Fill Material

1. In all backfilling of trenches and around structures, loose lumber, braces, rubbish and refuse shall be removed from the areas to be backfilled.
2. Backfilling shall be done with sound material free from waste, objectionable organic matter, rubbish, boggy or other unsuitable materials. No frozen material shall be used for backfilling.
3. Backfilling shall begin as soon as practicable after structures and pipelines have been installed and inspected. Material for bedding and backfill shall be as shown on the Drawings and as specified. The material shall be firmly compacted below and to points 12 inches above the crowns of conduits and pipelines. Temporary blocking shall not be allowed.
4. Backfill, in areas that are not required to be paved, shall be placed in uniform horizontal layers and shall be tamped, flooded or otherwise consolidated as the work progresses. Lumps of earth shall be broken up and if there are any stones or lumps which cannot be readily broken up, they shall be distributed throughout the mass so that all interstices are solidly filled with fine materials. No stone fragments, over 4 inches in any dimension, shall be placed in the backfill nearer than 2 feet from the pipe or conduit at any point, or from any concrete wall.
5. Backfilling over conduits, pipelines, chambers and manholes, in areas that are required to be paved (in roadways, paved shoulders, aprons, driveways, sidewalks, parking areas, etc.) shall be placed carefully and tamped or compacted with suitable tools. This material shall be placed in layers approximately 6 inches thick, each layers being thoroughly tamped and compacted in place.

In lieu of 6 inch lifts or layers and compacting as described above, the Engineer may approve the use of vibratory compactor-drivers mounted on rubber tire backhoes, to compact backfill. To prevent damage from down pressure and vibration, such equipment shall not be used nearer than 3 feet to existing utilities or to the pipe or conduit that is being installed. The cost of replacement of any utilities or work damaged due to the use of vibratory compactor-driers, shall be paid for by the contractor, and such cost shall be included in the unit and lump sum bid prices for pipe, chambers and manholes. Depending on the impulse

SECTION 02200 – PART III

force of such vibratory compactors, the Engineer may allow lift thicknesses of 2 to 3 feet. Where, from visual observation, the Engineer concludes that the required compaction may not have been attained, the Engineer may order that the work be stopped and a density test be performed. The cost of delays caused by such interruption of work and the cost of density tests shall be paid for by the Contractor, and such cost shall be included in the unit and lump sum bid prices for pipe, chambers and manholes.

6. Compaction Requirements for Backfill

a. Over Conduit and Pipelines and at Chambers and Manholes in Areas that are Required to be Paved

Backfill in areas that are required to be paved, such as roadways, paved shoulders, aprons, paved gutters, driveways, sidewalks, parking areas and other paved surfaces, shall be compacted to 95 percent of standard proctor maximum density.

b. For Structures

Backfill in areas of concrete slabs, foundations and fill in graded areas shall be compacted to 95 percent for granular materials or as indicated on the drawing.

3.04 COMPACTION OF MATERIALS

A. It shall be the Contractor's responsibility to properly place and compact all materials and to correct any deficiencies resulting from insufficient or improper compaction of such materials. The Contractor shall determine the type, size and weight of compactor best suited to the work at hand, select and control the lift (layer) thickness, exert proper control over the moisture content of the material, and other details necessary to obtain satisfactory results.

B. Compaction Equipment

1. The selection of compaction equipment is the Contractor's responsibility, but shall be subject to the approval of the Engineer. Generally, the following shall apply for the type of material to be compacted.

2. Sheepsfoot rollers shall be used to compact clay and glacial till soils. The proper ballasted weight shall be determined such that the feet penetrate to their full length on a loose lift to be placed, and with further passes, compact the layers are required.

3. Pneumatic or vibratory rollers shall be used to compact sands and gravel. Pneumatic rollers shall have operating weights between 2,000 and 3,000 pounds per tire.

4. Smooth steel wheel, pneumatic tired or vibratory rollers shall be used to compact slag, coarse gravel or crushed stone. Smooth steel wheel rollers shall have a

### SECTION 02200 – PART III

minimum weight of 10 tons. Where possible, rock rill shall be compacted using a self-propelled vibratory steel drum roller weighing at least 10 tons.

5. In all cases, loads shall be adjusted to give the most suitable results for the material being compacted. For heavier, or more efficient types of approved compaction equipment, the minimum number of passes required on all portions of each successive layer shall be determined by the Engineer after appropriate field tests to evaluate the efficiency of the equipment have been made. However, layer thickness shall not, under any circumstances, exceed those specified.

6. In confined areas, and adjacent to utilities, compaction shall be made using hand guided mechanical vibratory plate tampers or rollers similar to units manufactured by Wacker Neuson or Mikasa. Equipment for compaction of trenches in areas that are required to be paved shall be as outlined in Section 02200-3.03.

#### 3.05 SITE GRADING

A. Grading in preparation for placing of topsoil, planting areas, paved walks and drives and appurtenances shall be performed at all locations indicated on the Contract Drawings, to the lines and grades shown and as directed by the Engineer. All material encountered, of whatever nature, within the limits indicated, shall be removed and disposed of as directed. During the course of grading, the subgrade shall be maintained in such condition that it will be well drained at all times. When directed, temporary drains and drainage ditches shall be installed to intercept or divert surface water which may affect the prosecution or condition of the work.

B. When access roads are no longer needed, road fill shall be removed and the access area shall be restored. Care should be taken to avoid damage to adjacent vegetation and to prevent the formation of depressions that would serve as mosquito pools.

C. If at the time of grading it is not possible to place any material in its proper section of the permanent structure, it shall be stockpiled in approved areas for later use. No extra payment will be made for the stockpiling or double handling of excavated material.

D. The right is reserved to make minor adjustments or revisions in lines or grades if found necessary as the work progresses.

E. All loose or protruding rocks shall be barred loose or otherwise removed to line or finished grade of slope. All cut and fill slopes shall be uniformly dressed to the slope, cross-section and alignment shown on the Drawings or as directed by the Engineer.

F. Rough grading shall be stopped six inches below final grade and leveled off, and topsoil shall be placed and finished to final grade.



SECTION 02200 – PART III

G. The Contractor shall replace all surface material, and restore paving, curbing, sidewalks, gutters, fences and all other items which were disturbed by the construction so that they shall be equal to the original condition.

## SECTION 02215 – UTILITY PROTECTION

### PART I – GENERAL

#### 1.01 SCOPE OF WORK

The Contractor shall provide all labor, materials, tools, equipment and services required for the protection, relocation or replacement of public and private utilities as detailed herein.

### PART II – PRODUCTS

#### 2.01 PARALLEL UTILITIES

The costs of any necessary relocation or replacement of public utilities which are: 1) parallel or roughly parallel with the line of work and, 2) are located within the utility pay zone according to the pay limit for trench excavation as shown on the Detail Sheets, shall be compensated using applicable Bid Form Items where applicable. However, the Engineer may order the protection of these utilities by the Contractor, if, in the Engineer's opinion, they may be protected as opposed to being relocated or replaced. The Owner may also order the realignment of the proposed work to avoid relocation or replacement of public utilities where practicable.

#### 2.02 CROSSING UTILITIES

Utilities equal to or greater than 4-inches in diameter which cross the line of work at perpendicular angles or other skew angles shall be supported and protected, and payment shall be under the applicable contract Bid Form Items. If utilities which cross the line of work are found in direct conflict with the proposed work, the Contractor shall notify the Engineer. Utility crossings shall be protected as opposed to relocated or replaced, unless their condition within the trench excavation prevents that. Utility crossings that could have been protected as opposed to being relocated or replaced, in the opinion of the Engineer, will not be eligible of compensation on a unit price basis without approval in writing from the Engineer.

The Contractor shall be responsible for all house service lines (water, sewer, gas, electric, telephone and drain) and other utilities less than 4-inches in diameter which cross the line of work whether shown on the plans or not. The Contractor shall include in his bid costs to cover any extra work required at these crossings.

SECTION 02215 – PART III

PART III – EXECUTION

All utility protection shall be in conformance with all rules and regulations and in no case shall be less than the requirements of the utility company.

All utilities located outside the limits of the utility pay zone shall be protected or replaced at the Contractor's expense.

The Contractor shall be responsible for obtaining any permits required for utility protection, relocation or replacement.

The Contractor shall also be responsible for scheduling all work by the utility owners in accordance with his own work schedule.

In areas indicated on the plans and/or as ordered by the Engineer, the Contractor shall dig test pits for the purpose of accurately locating underground utilities. Those test pits indicated on the plans shall be completed immediately upon receipt of "Notice to Proceed".

## SECTION 02250 – TEMPORARY SHEETING, SHORING AND BRACING

### PART I – GENERAL

#### 1.01 SCOPE OF WORK

A. The Contract Drawings and Specifications represent the finished structure. Unless otherwise indicated, they do not indicate the method of construction. The Contractor shall provide all measures necessary to protect, but not limited to, the following:

1. existing utilities in their original position
2. existing structures in their original position
3. workmen or other persons
4. prevent lateral movement of earth adjacent to excavations
5. maintain the width of excavation as indicated on the Drawings.
6. protect construction equipment adjacent to the excavation
7. protect adjacent new work

The Contractor, at his own expense, shall engage properly qualified Professional Engineers registered in New York State to determine where, and how, temporary precautionary measures shall be used and inspect same in the field. Observation visits to the site by the Project Engineer's Field Representative shall not include inspection of the above items. Designs shall take into account the Contractor's program for dewatering.

The Contractor shall supervise and direct the work and he shall be solely responsible for all construction means, methods, techniques, sequences and procedures including maintenance and removal. As a part of his responsibility, the Contractor shall retain the services of a licensed Structural Engineer other than the Owner's representative to design and supervise the above work.

B. The Contractor shall control his operations to avoid damage to existing structures from ground vibrations caused by blasting, pre-driven sheeting or other operations.

C. ALL OPEN EXCAVATIONS OF DEPTHS GREATER THAN 4'-0" AS MEASURED FROM THE SURFACE SHALL BE SHEETED, SHORED AND BRACED. All sheeting, shoring and bracing shall conform to the provisions of the Williams-Steiger Occupational Safety & Health Act of 1970 (a amended), Public Law 91596 – Part 1518 – Safety & Health Regulation for Construction and/or the New York Department of Labor Industrial Code Rules, whichever is more strict.

D. Bracing, sheeting, and shoring shall be so arranged as not to place any stress on portions of completed work until the construction has proceeded far enough, in the opinion of the Contractor's Engineer, to provide ample strength. If the Contractor's Engineer is of the opinion that the sheeting or supports furnished are inadequate or unsuited for the purpose, he may order additional sheeting or supports to be installed at no added cost to the Owner. Whether so ordered by the Contractor's Engineer or not, sufficient sheeting or supports shall be installed to protect the work from any damage to new or existing structures.

## SECTION 02250 – PART I

E. Waling and bracing shall be provided as a part of the work under this item.

F. A copy of all sheeting, sheet piling and bracing systems shall be submitted to the Project Engineer for his use and information before installation of same. Each sheet shall display and seal and signature of a licensed New York State Professional Engineer. A copy of this information must also be submitted to the Agency having jurisdiction for review and approval.

G. When pre-driven sheeting is required, the Contractor shall employ specialists to conduct pre-construction surveys of structures in the vicinity of the work, and to monitor the effects of the ground vibrations.

1. Preconstruction survey shall be conducted on and reported for all major structures within the influence range of the sheeting operation or within a minimum of 300 feet from the construction site. The survey shall consist of a visual inspection and recording by notes and photographs or cracks or other structural damage previously sustained, and shall be conducted by a qualified technician under the direct supervision of a Professional Engineer, acceptable to the Engineer. The records so obtained shall be retained in the Contractor's file for at least one year after completion of the Contract. In the event of damage claims, a report on the preconstruction conditions shall be prepared by the Contractor for the particular structures as requested by the Engineer from those notes and photographs.

2. Sheeting vibrations shall be monitored by a qualified specialist, acceptable to the Engineer and shall be retained to observe the pre-driven sheeting operation. A seismograph shall be employed to measure ground vibrations near selected typical private and/or public buildings within the range of influence of the operation. Seismograms and records of information pertinent to each operation shall be available to the Engineer. The recorded information shall be adequate to allow determination of the vibration.

## PART II – PRODUCTS

### 2.01 MATERIALS

A. Wood sheeting, shoring and bracing shall be of such quality and size that it will not split. Sheeting and bracing shall be Southern Pine, a structural grade, of 1800 psi stress class, and furnished in accordance with the standard rules and grading, dressing and inspection of joints, planks, beams and stringers of the Southern Pine Association. Douglas Fir or other timber of equivalent grade may be substituted. Materials may be either new or used in good condition. Where close or right sheeting is required, wood sheeting shall be tongued and grooved.

B. Steel sheeting shall be manufactured from steel conforming to ASTM Designation A-328, latest revision, and bracing buildings ASTM Designation A-36, latest edition. The sizes and types required may be indicated on the Plans, or if not so shown, steel sheeting shall have a minimum thickness of 3/8 inch in web, unless approved otherwise by the Engineer, and

## SECTION 02250 – PART II

flange shall be as detailed by the Contractor. All necessary welding or supporting members shall be done in accordance with requirements of the American Welding Society Code.

## PART III – EXECUTION

### 3.01 INSTALLATION

A. Shall be installed in accordance to code requirements.

1. All sheeting shall be right and continuous, and driven vertically in place ahead of the excavation by means of steam, vibratory or pneumatic hammers. Any material which stops and driving of sheet piling shall be removed by the Contractor.

2. The sheeting shall extend at least 2 feet above the surface of the ground. If, in the opinion of the Engineer, an excavation will constitute a safety hazard, the sheeting shall extend at least 4 feet above the surface of the ground.

3. As soon as sheeting is placed, if there is a space between the sheeting and the side of the trench, the space shall be backfilled with suitable material thoroughly compacted in place.

B. Removal of Sheeting

1. In general, the sheeting and bracing shall be removed as the excavation is refilled in such a manner as to avoid the caving in of the bank or disturbance of adjacent areas or structures. The voids left by the withdrawal of the sheeting shall be carefully filled by ramming or otherwise, as directed. Permission of the Engineer shall be obtained before the removal of any shoring, sheeting or bracing.

2. Such permission by the Engineer shall not relieve the Contractor from the responsibility for injury to structures, or to other property or persons, from failure to leave such sheeting and bracing in place.

C. Sheeting Left in Place

1. The Engineer may order, in writing, any or all sheeting or bracing to be left in place for the purpose of preventing injury to the structures or to other property or to personal, whether such sheeting or bracing was shown on the Plans, or placed at his direction, or otherwise. If left in place, such sheeting shall be cut off at the elevation ordered, or shown on the Plans, but in general, such cut off shall be at least 18" below the final ground surface. Bracing remaining in place shall be driven up tight.

## SECTION 02300 – STORM SEWERS & APPURTENANCES

### 1.01 RELATED WORK

A. Refer to Sections 02100, 02150, 02200, 02250, 02376, 02600, 02800 and 03300.

### 1.02 SCOPE OF WORK

A. The Contractor shall furnish all labor, material and equipment to install as shown on the Plans or as described in Work Orders, the storm sewers, including pipe, fittings, manholes, catch basins and other appurtenances required to complete the work.

### 1.03 SUBMITTALS

A. Shop drawings will be required for all fabricated and/or manufactured material items required by the specifications for this Section.

## PART II – PRODUCTS

### 2.01 STORM SEWER PIPE AND UNDERDRAIN

A. New storm sewer pipe shall be as shown on the Plans, indicated in Work Orders, and in accordance with Standard Details. Repairs to crossing utilities, where directed, shall be made with in-kind materials.

B. Underdrain pipe shall be replaced in-kind, or at minimum shall be 6” perforated corrugated polyethylene underdrain pipe and shall meet the requirements of NYSDOT Specification Section 605. Underdrain filter material shall be Type 1 and shall meet the requirements of NYSDOT Specification Section 733. Underdrain filter material shall be placed in compliance with requirements of NYSDOT Specification Section 605. Stabilization/separation geotextile shall be Mirafi 160N or approved equal.

### 2.04 PRECAST CONCRETE STORM MANHOLES

A. All storm manholes shall be as shown on the Plans, indicated in Work Orders, and in accordance with Standard Details.

B. Standard manhole frames and covers shall be provided by Owner for installation by Contractor and shall be in accordance with Standard Details.

### 2.05 PRECAST CATCH BASINS (RECEIVERS) AND GRATES

A. The precast basin shall be monolithic reinforced concrete of the type and size shown on the plans. The precast unit shall be capable of supporting an H-20 highway load. The bottom floor of the monolithic precast basin shall have a minimum thickness of 6 inches.

## SECTION 02300 – PART III

B. All catch basins shall be as shown on the Plans, indicated in Work Orders, and in accordance with Standard Details.

### PART III – EXECUTION

#### 3.01 PIPE INSTALLATION

A. Sewer pipe shall be laid in a carefully compacted initial bedding material placed on a flat trench bottom. Bedding shall conform to details shown on the Plans.

B. In laying pipe, the subgrade of the trench shall be carefully formed so that the pipe will rest at the correct line and grade.

#### 3.02 CATCH BASIN CONNECTIONS

A. Connections to existing catch basins shall be at the location shown on the Plans.

B. The proposed pipe connections shall be parged to the catch basin on the outside and inside with “Preco-Patch” or equal, to provide a watertight connection.

#### 3.03 FINAL INTERNAL INSPECTION OF STORM SEWER SYSTEM

A. After installation of the pipe and prior to final restoration of the project area, the contractor will be required to clean all debris and sediments from the storm sewer system. Once the pipe and chambers are cleaned, the Owner shall complete an internal television inspection of the system. The internal inspection shall view and determine the following:

1. The system is free from obstructions, debris and sediment.
2. The pipe sections are free of cracks and defects.
3. The pipe joints are properly coupled and sealed.
4. The pipe (invert) is laid at a consistent grade free of dips and/or high points
5. The installed system shows no signs of leakage.
6. That all lateral drainage connections are properly made and watertight.

If a system deficiency is noted by the Engineer, the Contractor will be required to immediately clean, replace and/or repair the system at his own expense.



SECTION 02350 – FORCE MAIN SEWERS

PART I – GENERAL

1.01 RELATED WORK

A. Refer to Section 02100, 02150, 02200, 02600, 03300, 15002, 15003 and 15006.

1.03 SUBMITTALS

A. Shop drawings will be required for all fabricated and/or manufactured material items required by the specifications for this Section.

PART II – PRODUCTS

2.01 DUCTILE IRON PIPE

A. Pipe

1. Unless otherwise specified, all ductile iron pipe shall conform to ANSI/AWWA C151/A21.51, ductile iron pipe centrifugally cast in metal molds or sand-lined molds for water or other liquids.

2. All ductile iron pipe shall be minimum thickness Class 52 (ANSI 21.50) unless otherwise specified and shall be cast in 18 foot laying lengths.

3. The pipe class designation, diameter size, and pressure rating shall be cast or painted on each piece of pipe or fittings.

4. All ductile iron pipe and fittings shall be cement mortar lined and then bituminous painted inside and outside.

B. Fittings

1. Unless otherwise specified, all fittings shall conform to ANSI A21.10, ductile iron fittings.

2. All ductile iron fittings shall be manufactured in classes suitable for the class and size of pipe with which they are intended to be used.

3. All ductile iron fittings shall be cement mortar lined and then bituminous painted inside and outside.

## SECTION 02350 – PART II

### C. Joints

1. All ductile iron pipe and fittings, unless otherwise specified, shall be furnished with push on or mechanical joints.

2. All push on joints, unless otherwise specified shall conform to the following requirements:

a. All push on joint gaskets shall conform to applicable requirements of ANSI A21.11, and shall be designed for the same pressure rating as the pipe or fitting of which it is a part.

b. Gaskets shall be plain rubber gaskets.

3. All mechanical joints, unless otherwise specified, shall conform to the following requirements.

a. All mechanical joints shall conform to applicable requirements of ANSI A21.11, and shall be designed for the same pressure rating as the pipe or fitting of which it is a part.

b. Gaskets: Plain tip

c. Bolts and Nuts: High strength, low alloy steel, fluorocarbon coated as manufactured by Standco Industries, Inc. of Houston, Texas or approved equal.

4. All force main sewers shall require anchorage at each fitting causing a change in direction of 7 ½ degrees or greater. All 24 inch diameter pipe and larger shall be anchored together with either a bolted type or harness ring type and restrained joint. Pipes under 24 inches in diameter may be restrained with 4000 psi concrete blocking or a combination of concrete blocking and mechanical restraint as noted on the Plans.

5. The type of restrained joint to be used shall be approved by the Engineer prior to ordering the pipe.

6. Making the joint and laying the pipe shall comply with applicable sections of the AWWA Specifications except that no sulphur compound type of joint shall be allowed.

### D. Insulation

1. Two inch (2”) thick closed cell rigid insulation shall be installed above the ductile iron pipe (DIP) force main in the insulated cover areas noted on the Plans.

## SECTION 02350 – PART II

### 2.02 POLYVINYL CHLORIDE (PVC) PLASTIC PIPE

#### A. Pipe

1. Unless otherwise specified, all PVC pipe for force mains shall conform to the latest AWWA C-900 Specification for polyvinyl chloride pressure pipe.
2. All PVC pipe shall be C-900 having a dimension ratio (DR) of 18, unless otherwise specified, and shall be manufactured in 20 foot laying lengths. The pipe shall have a pressure rating of 150 psi and shall have a cast iron equivalent outside diameter.
3. All supplied PVC pipe shall be side marked with the class type, material code (PVC 1120), dimension ratio number, AWWA pressure class, nominal size and outside diameter base dimension.
4. The materials used in the manufacturing of the PVC Pressure Pipe (PVC 1120) shall be made from Class 12454-A or Class 12454-B Virgin Compounds, as defined in ASTM C-1784, with an established hydrostatic design-basis (HDB) rating of 4000 psi for water at 73.4 F (23C).

#### B. Joints

1. Pipe joints shall be the Fluid-Tite IB (Intregal Bell) push-on type gasketed joint which shall be an integral and homogeneous part of the pipe barrel. The push-on joints and elastomeric gaskets shall conform to the requirements of ASTM D3139 and F477, respectively.

#### C. Fittings

1. All required fittings shall be ductile iron conforming to the latest edition of AWWA C-100. Fittings shall have mechanical joints and be compatible with the proposed PVC water pipe.
2. All fittings shall be manufactured in classes suitable for the size of pipe and pressure rating as indicated.
3. All bends, tees, valves and other fittings shall be anchored with thrust blocks, as shown and detailed in the plans. Thrust blocks shall be placed against a solid bearing face of undisturbed material. The concrete shall have a strength of 2000 psi or shall be mixed in the proportions of one (1) sack (94 lbs.) of Portland Cement to 2 ½ cubic feet of loose sand to 5 cubic feet of loose gravel or broken stone. For thrust blocks placed during connection operations, a quick-setting additive shall be mixed into the concrete prior to placement. Where blocking is placed for downward vertical bends or valves the bends or valves shall be strapped to the blocks as shown in the drawings, or as otherwise directed by the Engineer.

## SECTION 02350 – PART II

### D. Insulation

1. Two inch (2”) thick closed cell rigid insulation shall be installed above the polyvinyl chloride (PVC) force main in the insulated cover areas noted on the plans.

## PART III – EXECUTION

### 3.01 DUCTILE IRON PIPE – BELL AND SPIGOT (PUSH ON) JOINTS

#### A. Mechanical Joint Pipe

The contractor shall brush clean the pipe’s socket, plain end and gasket with soapy water, then lip gland and gasket over the plain end of the pipe. The small side of gasket and lip side of gland shall face the socket. Insert plain end of pipe into socket and push gasket into position with fingers making sure it is evenly seated. Slide gland into position inserting bolts and tightening by hand. With ratched wrench tighten up bolts in an alternating fashion (top – bottom etc.) pursuant to the manufacturer’s recommendations. It shall be noted the contractor is to store all gaskets in an area where a 40 degree F or above air temperature to maintained.

#### B. Bell & Spigot (Push On) Joints

1. Gasket type bell and spigot piping, unless otherwise specified, shall be installed as described herein. Prior to making up the joint, the inside of the bell, the entire gasket and the spigot end of the joining pipe shall be thoroughly cleaned with soapy water, using a sponge or rag to remove all foreign material. The rubber molded gasket shall then be placed in the bell. Please note all gaskets must be stored in areas where a 40 degree F or above temperature is maintained. Once the gasket is properly seated the gasket and surface of the spigot end of the joining pipe shall be lubricated in accordance with the manufacturer’s recommendations. The spigot shall then be centered into the bell until it engages the gasket, and force applied to make the joint. Any deflection shall be taken after the joint assembly has been completed. Force to make the assembly can be supplied by means of a pinch bar applied to wood blocking at he bell end of the joining pipe in diameters of 3 inches to 12 inches. Other mechanical means such as a chain and ratchet shall be used to assemble sizes larger than 12 inches.

### 3.02 PVC PIPE, LOCKING JOINT

A. Prior to assembly, the coupling matching grooves in the male and female ends shall be wiped clean, then lightly coat the “O” ring male end of the pipe with a lubricant.

B. Immediately after the lubricant is applied, the coupling shall be slipped together until the pipe end seats against the stop.

## SECTION 02350 – PART III

C. The nylon spline is pushed into aligned grooves around the pipe's circumference, securely locking the pipe to the coupling.

### 3.03 PVC PRESSURE PIPE (FLUID-TITE IB JOINT)

A. Prior to assembly, clean the bell and spigot ends of the coupling to remove all dirt and other foreign materials.

B. Check the rubber gasket in the bell groove in accordance with the manufacturer's instructions.

C. Apply lubricant to exposed gasket surface and to the pipe spigot up to the full insertion mark.

D. Immediately after the lubricant is applied, insert the spigot end until it is flush with the reference mark.

### 3.04 TRACER TAPE

A. Magnetic plastic tracer tape (with wire) 3" in width will be required when either Ductile Iron or PVC pipe is utilized. The tracer tape shall be green in color and shall be labeled "Sanitary Sewer". The tape shall be placed 12" below grade and shall be strung along the centerline of the sewer. Splices where needed shall be made in accordance with the manufacturer's recommendation.

B. At completion of the project, and before final payment, the Contractor shall test the entire length of the pipe using pipe location equipment. Test shall be made only in the presence of the Engineer. Any section of tape which is not continuous or is undetectable shall be removed and relaid.

## PART IV – TESTING

### 4.01 PRESSURE

After the sewerage force main has been laid and the joints completed, this newly laid pipe shall, unless otherwise specified, be subjected to a hydrostatic pressure test with a minimum pressure of 1 ½ times the normal operating pressure.

### 4.02 DURATION

The duration of each pressure test (1 and 2) shall be at least 2 hours.

## SECTION 02350 – PART IV

### 4.03 PROCEDURE

The pipe shall be slowly filled with water and the specified test pressure, measured at the point of lowest elevation, shall be applied by means of a pump connected to the pipe in a satisfactory manner. The pump, pipe connections, all necessary apparatus, taps into the pipe,

gauges, and measuring devices, will be furnished by the Contractor. All work shall be accomplished by the Contractor.

Testing shall be done as soon as the line is completed as determined by the Engineer. All testing shall be witnessed by the Engineer.

### 4.04 EXPELLING AIR BEFORE TESTING

Before applying the specified test pressure, all air shall be expelled from the pipe. To accomplish this, taps shall be made, if necessary, at points of highest elevation and afterwards tightly plugged.

### 4.05 EXAMINATION UNDER PRESSURE: TEST NO. 1

All exposed pipes, joints and fittings which are exposed when the test is conducted shall be carefully examined for visible leakage. Those portions of the pipe line covered by backfill shall be walked to observe leakage appearing on the ground surface. Any leaks discovered in the joints shall be corrected until tight. Any cracked or defective pipe, fittings, etc., discovered in consequence of this pressure test shall be removed and replaced by the Contractor, at his expense, with new material as previously specified and the test repeated until satisfactory to the Engineer.

### 4.06 PERMISSIBLE LEAKAGE: TEST NO. 2

Suitable means shall be provided by the Contractor for determining the quantity of water loss by leakage under normal operating pressure. No pipe installation will be acceptable until or unless this leakage is less than that specified under Division 1.

Should any test of pipe laid disclose leakage per mile of pipe greater than that specified in Division, the Contractor shall, at his own expense, locate and repair the defective joints or pipe until the leakage is within the specified allowable.

### 4.07 LEAKAGE DEFINED

Leakage is defined as a the quantity of water to be supplied into the newly laid pipe necessary to maintain the specified leakage test pressure after the pipe has been filled with water and the air expelled. The allowable leakage is specified in Division 1.

## SECTION 02375 – SANITARY SEWERS

### PART I – GENERAL

#### 1.01 SCOPE OF WORK

A. Furnish all labor, materials, equipment and incidentals required, and install in the locations shown on the Drawings, all sanitary sewer piping and fittings as specified herein.

#### 1.02 RELATED WORK

A. Refer to Section 02100, 02150, 02200, 02250, 02376, 02600, 02800 and 03300.

#### 1.03 SUBMITTALS

A. Shop drawings will be required for all fabricated and/or manufactured material items required by the specifications for this Section.

### PART II – PRODUCTS

#### 2.01 POLYVINYL CHLORIDE (PVC) GRAVITY PIPE

##### A. Pipe

1. For pipe diameters 4” thru 15”, the polyvinyl chloride (PVC) pipe shall be a single wall pipe conduit as manufactured in accordance with the latest ASTM Specification D-3033 “Type PSP Poly (Vinyl Chloride) (PVC) Sewer Pipe and Fittings” or ASTM Specification D-3034 “Type PSM Poly (Vinyl Chloride) (PVC) Sewer Pipe and Fittings”. For pipe diameters 18” thru 27”, the PVC pipe manufacturer shall satisfy the requirements, of the latest ASTM Specification F-679, Type I. All pipe shall be SDR-35 or thicker single wall and the PVC Compound shall meet the requirements of the latest ASTM Specification D-1784. Pipe in compliance with these standards shall be clearly marked with pipe size (nominal), cell classification, SDR number, PVC Sewer Pipe and ASTM Designation.

2. All pipes shall be suitable for use as a gravity sewer conduit. Provisions must be made for contraction and expansion at each joint with a rubber ring. The bell shall consist of an integral wall section which securely locks the solid cross-section rubber ring into position.

3. Where directed by the Engineer, AWWA C-900 PVC pipe and fittings shall be installed as a gravity sewer pipe at locations shown on the Plans.

##### B. Joints

1. The joint shall provide a permanent seal against exfiltration or infiltration. The joining technique will be with elastomeric gasket.

## SECTION 02375 – PART II

2. Elastomeric Gasket Joints – The critical sealing dimensions of the bell, spigot and gasket shall be in accordance with the manufacturer’s standard dimensions and tolerances. The elastomeric compound shall comply in all respect with the physical requirements specified in ASTM F-477-76. The gasket shall provide an adequate compressive force against the sealing surfaces of the bell and spigot so as to affect a positive seal under all combinations of the joint tolerances. The gasket shall be the only element depended upon to make the joint flexible and watertight. The gasket material shall be oil and gasoline resistant.

### C. Fittings

1. All PVC wyes, tees, elbows, couplings, and fittings shall be manufactured in classes suitable for the class of pipe with which they will be used.

2. All fittings and accessories shall be as manufactured and furnished by the pipe supplier, and have bell and/or spigot configurations identical to that of the pipe to which they are connected. The joint shall provide a permanent seal against exfiltration or infiltration. The joining technique will be with elastomeric gasket. Service connections shall be of the "tee-wye" combination. The PVC pipe shall be cut to the correct length in the field as necessary to allow installation of new service connections or service connections to existing laterals. Refer to Standard Details for additional information on service connections.

### 2.02 FLEXIBLE PIPE COUPLINGS

A. Where new PVC piping will be connecting to existing sewers, the gaskets, clamps, shear rings, and/or other components of the coupling system shall meet the material requirements of ASTM C-1173 “Standard Specification for Flexible Transition Couplings for Underground Piping Systems”. The coupling system shall be specifically manufactured to connect the new PVC piping to the particular existing pipe materials, such as products by Fernco, or approved equal.

B. Shielded flexible couplings shall consist of a flexible PVC sealing sleeve, stainless steel clamps and a stainless-steel outer shield (shear ring) and shall be utilized for all connections to existing sewers.

### 2.03 HEAVY DUTY CLEANOUT HOUSING

A. For cleanouts to be installed in sidewalks, driveways, or roadways where shown on the Plans or as directed by the Engineer, install heavy-duty cast-iron housing.

B. Housing shall be round cast iron meeting ASTM A48, Class 35 constructed with an integral double anchor flange. Provide vandal proof screw. Inside diameter of housing shall be a minimum of 11 inches. Outer flange diameter shall be a minimum of 14 inches. Provide stainless steel fasteners. Cover shall be labelled “Sewer”.

C. Provide EJ #3698 Assembly, or approved equal.



## SECTION 02375 – PART II

### 2.04 FLEXIBLE TAP SADDLES

A. Provide Fernco Flexible Wye Tap Saddle with Fernco TSPK-46 Pressure Kit for Flexible Tap Saddle, or accepted equal.

1. Tap Saddles shall be leak-proof, and resistant to chemical, ultraviolet rays, fungus growth, and sewer gases.
2. Saddles shall conform to ASTM D5926.
3. Maximum operating temperature: 140 degrees F.
4. Saddle shall be manufactured with a “locating ring” on the underside of the saddle for insertion into the cored hole.
5. Saddle shall be installed utilizing a manufacturer’s recommended pressure kit. Pressure kit shall include bentonite tape to provide a water tight seal, plastic-coated steel reinforcing bars to apply even sealing pressure, and 300 series stainless steel slip-lock clamps.

## PART III – EXECUTION

### 3.01 LAYING PIPE

#### A. Pipe

1. All sanitary sewer pipe shall be constructed in accordance with Division 2 of these Specifications.
2. All sanitary sewer pipe shall be bedded as detailed on the Construction Plans and all work shall be in accordance with the various details shown on the Plans.
3. All pipe shall be cleaned before placing, bulkheaded when pipe laying is stopped, and otherwise constructed to secure first class work, free from defects and debris.
4. All sanitary sewers shall be laid true to line and grade with bells up grade. In laying pipe, the subgrade of the trench shall be carefully formed so that the pipe will rest at the correct line and grade. Line and grade for pipe installation shall be maintained by the use of a laser beam projection system. The laser system shall include ability to set and adjust the grade based on a dial indication. Any proposed alternate system to maintain line and grade shall be submitted to the Engineer and approval obtained prior to use.
5. Pipe used for this project shall be subjected to factory testing at the Owner’s option and Contractor’s expense. Testing shall be in job lots for a maximum of 6% of pipe quantity or a minimum of 5% of pipe quantity or 2 pieces of each size in each class. Factory tests shall be hydrostatic or air tests up to 24” and hydrostatic tests for over 24”, including all other material tests as specified by ASTM.

## SECTION 02375 – PART III

### B. Wye Branches

Where testing is required or directed by the Engineer, the wye branches shall have approved caps or plugs factory installed on the six (6) inch branches for testing purposes. The wye branches shall be bedded and supported as detailed on the Plans.

### C. Tee Branches

Tee branches shall only be allowed on PVC AWWA C-900 pipe. Tee branches shall have approved caps or plugs factory installed on the six (6) inch branches for testing purposes. The tee branches shall be bedded and supported as detailed on the Plans.

### D. Tap Saddles

Where indicated on the Plans or as directed by the Engineer, connections to the existing sewer mainlines shall be made via tap saddles. A trench shall be excavated exposing the outside diameter of the sewer main. The existing lateral pipe shall be disconnected from the mainline sewer and removed. Where the mainline sewer is rehabilitated cured in place pipe lined pipe, the saddle shall be installed directly to the CIPP liner and existing host pipe shall be removed to facilitate this. The existing mainline should be cored/cut/enlarged or modified as required using a coring bit or hole saw to match the contour of the Tap Saddle locating ring. All tap connections shall be made as required to provide connection with a 6-inch diameter PVC SDR 35 sewer lateral pipe. The pipe surface shall be cleaned and any sharp edges removed. The tap saddle should be installed according to all manufacturer's recommendations.

### E. Riser Pipe

1. All riser pipes shall be constructed according to the details shown on the Plans or as ordered by the Engineer in the field.

2. Riser pipes installed in areas where house laterals are not required, or not installed yet, shall have the last length of pipe sealed with a cap or plug. Such caps or plugs shall be wired in place so as to withstand pressures during testing. Compacted No. 1 stone bedding shall be provided to support as shown on the Plans.

### F. House Laterals

House laterals shall be 6 inch diameter, at depths of cover varying from up to 8 feet, or as shown on the Plans, at locations to be determined by the Engineer in the field. The type and class of pipe, along with bedding details are shown on the Plans.

### G. Markers

A two inch by 4 inch wood marker extending from the tee branch, wye branch, riser or lateral to a point one foot below the ground surface, at each shall be provided.

## SECTION 02375 – PART III

### H. Records

The location of wye branches, tee branches, riser pipes, and cleanouts along with laterals shall be measured from the last downstream manhole and in addition, shall be located on a sketch by the use of at least two ties to existing structures, preferably the corners of the house. Such records shall identify the house and laterals by house number; the records shall be kept by the Contractor with three copies delivered to the Engineer within one day after installation. Each record of a wye branch, tee branch, riser pipe or house lateral shall be on a separate sheet. This information shall be transferred to the as-built tracings by the Contractor.

### I. Concrete Cradle and Encasement

Where noted on the Plans or as directed by the Engineer, 2000 psi dry mix concrete shall be placed for bedding and pipe protection. The cradle and encasement details are shown on the Plans. The concrete shall be as specified under Section 03300.

## 3.03 PIPE TESTING AND INSPECTION REQUIREMENTS

### A. General

1. New manhole to manhole sewer installations in a new trench shall be subject to the following tests/inspections prior to final acceptance of the project:

- a. Air Tests (performed by Contractor)
- b. Visual Inspection (by CCTV) (performed by Owner, unless directed otherwise in the Work Order)
- c. Deflection Test (15" dia. and smaller) (only where directed in writing by the Engineer, and to be performed by Contractor).

2. Sewer installations that include replacement in the existing trench (including sewer spot repairs) and require maintenance of live sanitary sewer flows during installation shall be subject to the following tests/inspections prior to final acceptance of the project:

- a. Visual Inspection (by CCTV) (performed by Owner, unless directed otherwise in the Work Order)
- b. Deflection Test (15" dia. and smaller) (only where directed in writing by the Engineer, and to be performed by Contractor).

### B. Air Testing

1. After backfilling and prior to the final acceptance of the project, the Contractor will be required to perform the air tests on manhole to manhole sewer installations.

SECTION 02375 – PART III

3. To facilitate the air testing, laterals and risers are to be installed and capped, tied and blocked as the work progresses, and prior to the air testing of the lines.

4. The Contractor’s testing procedures shall be completed in accordance with OSHA Standards for confined space entry. The Contractor will be required to provide and operate all equipment necessary for full compliance. Equipment such as gas detectors, safety harnesses, ventilating blowers, respirators etc., shall be provided by the Contractor.

5. The procedures for air testing shall be as specified herein and as ordered by the Engineer. The minimum allowable time for the test pressure to decrease from 3.5 psi to 3.0 psi shall be not less than as called for in the following table:

<u>Pipe Diameter</u>	<u>Minimum Acceptance Times for Length Shown (min:sec)</u>			
	<u>Up to 100’</u>	<u>100 – 200’</u>	<u>200 - 300’</u>	<u>300 - 500’</u>
6”	2:50	2:50	2:50	2:51
8”	3:47	3:47	3:48	5:04
10”	4:43	4:43	5:56	7:54
12”	5:40	5:42	8:33	11:24
14”	6:36	7:50	11:45	15:40
15”	7:05	8:54	13:21	17:48

<u>Pipe Diameter</u>	<u>Up to 100’</u>	<u>100 – 200’</u>	<u>200 - 300’</u>	<u>300 - 500’</u>
16”	7:33	10:20	15:18	20:41
18”	8:30	12:49	19:14	25:38
20”	9:27	15:54	23:52	31:49
21”	9:55	17:27	26:11	34:54
24”	11:24	22:48	34:11	45:35
27”	14:25	28:51	43:16	57:42
30”	17:48	35:37	53:25	71:13
33”	21:33	43:56	64:38	86:10
36”	25:39	51:17	76:55	102:34

2. Pipe lines in sizes up to 36 inches in diameter can be air tested from manhole to manhole for distances not to exceed 500 feet.

3. In wet trenches where pumping to lower the water table is impractical, approved perforated pipe (with approved cap) shall be placed at each manhole to extend from a point 6 inches below the lowest invert to the top of the ground. Ground water elevations will be measured at each manhole in order to calculate the groundwater pressure acting on the pipe exterior. The initial air test pressure shall be increased as necessary to overcome the calculated groundwater pressure.

SECTION 02375 – PART III

4. The testing procedure outlined shall be strictly adhered to during construction.

5. All testing equipment shall be supplied by the Contractor at his expense. For the Contractor's information, some of the major equipment required for air tests is the following:

- a. Stop watch graduated in tenths of a second
- b. Compressor of 50 to 100 psi capacity
- c. Bulkheads for pipe
- d. Approximately 100 feet of 3/8" diameter air hose
- e. Pressure gauge – 0 to 5 psi graduated in 1/16<sup>th</sup> of a pound increments
- f. Three 3/8 inch diameter check valves.

B. Visual Inspection

1. All pipes shall be visually inspected by the Engineer prior to final acceptance. All equipment and labor required for the internal inspection shall be furnished by the Owner, unless the Contractor is directed in writing by the Engineer to provide it and directs payment under the applicable bid item. The CCTV equipment and procedures shall, at minimum, meet the following requirements:

a. Camera and Recording Equipment: The video camera used for the inspection shall be one specifically designed and constructed for such inspection. Lighting for the camera shall be suitable to allow a clear picture for the entire periphery of the pipe. The camera shall be operative in 100% humidity conditions. The camera, television monitor, recorder and other components of the video system shall be capable of producing a minimum 500 lines resolution video picture in living color. Picture quality and definition shall be to the satisfaction of the Owner's representative and if unsatisfactory, equipment shall be removed and no payment made for unsatisfactory inspection.

b. Power Cable: The power cable attached to the camera must be of sufficient length to insure televising the entire pipe section from the one manhole to manhole. Any delays in television inspection or additional equipment set ups caused by insufficient length of cable, will be the responsibility of the Contractor.

c. Preparation: CCTV equipment shall be set up in the preparation for television inspection. Equipment set up shall include necessary traffic control, positioning of winches, power cable hook-up, CCTV camera preparation and positioning of the CCTV camera in the manhole.

SECTION 02375 – PART III

d. Internal Inspection: The camera shall be moved through the line in either direction at a uniform rate, stopping when necessary to insure proper documentation of the sewer's condition but in no case will the television camera be pulled at a speed greater than 30 feet per minute. Manual winches, power winches, TV cable, and powered rewinds or other devices that do not obstruct the camera view or interfere with proper documentation of the sewer conditions shall be used to move the camera at a uniform speed through the sewer line.

e. Whenever non-remote powered and controlled winches are used to pull the television camera through the line, telephones or other suitable means of communication shall be set up between the two manholes of the section being inspected to insure good communication between members of the crew.

f. Measurement for location of any defects shall be above ground by means of the meter device. Marking on cable, or the like, will not be allowed. Measurement meters will be accurate to one tenths (0.1) of a foot over the length of the section being inspected. Accuracy of the measurement meters shall be checked daily by use of a walking meter, roll-a-tape or other suitable device.

g. Documentation of the television results shall be as follows: Television inspection logs (PDF format) and Video recordings (saved on DVD or USB flash drive). Some items of inspection are as follows:

- i. Pipe free from obstructions and debris
- ii. Pipe free from cracks
- iii. Pipe joints properly sealed
- iv. Pipe invert is smooth and free of sags or high points
- v. Hookups, diversions and connections properly made
- vi. Concrete pipe walls free from structural defects
- vii. Pipes and joints free from visible signs of leakage
- viii. Specified coatings properly installed as applicable

2. Pipe sections and joints not meeting all of the above requirements shall be replaced or repaired as directed by the Engineer at the Contractor's expense.

C. Deflection Test:

Where directed by the Engineer, sewers constructed under this project shall be internally checked, no earlier than 30 calendar days after the trenches are backfilled, with a five percent (5%) deflection "go-no-go-pig" to determine if the pipes are deflecting. Any section of pipe unable to pass the "pig test" shall be removed and replaced at the Contractor's expense.

## SECTION 02375 – PART III

### D. Infiltration/Exfiltration Testing of Sanitary Sewer Manholes

Pursuant to Section 02376, the Contractor is required to complete and pass an Infiltration or Exfiltration test on all sanitary sewer manholes installed under this contract. Subject to the approval of the Engineer, the testing of the manholes can be completed jointly with the testing of the installed sanitary sewer pipe. The Contractor is advised to refer to Section 02376, Item 30.2 for the actual testing requirements associated with the sanitary manholes.

### 3.04 SEPARATION OF WATER MAINS AND SEWERS

#### A. General

1. When proposed or replacement sewers are to be replaced in the vicinity of water supply facilities or utilities, proper horizontal and vertical separation distances shall be complied with to meet Ten States Standards "Protection of Water Supplies" Standard 38. Where separation is not possible, alternative pipe materials or concrete encasement may be required and shall be compensated under applicable bid items.

#### B. Horizontal Separation

1. Sewers shall be laid at least 10 feet horizontally from any existing or proposed water main. In cases where it is not practical to maintain a 10 foot separation, the appropriate reviewing agency may allow deviation on a case by case basis, if supported by data from the Engineer. Such deviation may allow installation of the sewer closer to a watermain if,

- a. It is laid in a separate trench, or if
- b. It is laid in the same trench with the water main located at one side of a bench of undisturbed earth, and if
- c. In either case the elevation of the top (crown) of the sewer is at least 18" below the bottom (invert) of the water main.

#### C. Vertical Separation

1. Sewers crossing watermains shall be laid to provide minimum vertical distance of 18" between the outside of the watermain and the outside of the sewer. This shall be the case where the watermain is either above or below the sewer. The crossing shall be arranged so that the sewer joints will be equidistant and as far as possible from the watermain joints. Where a watermain crosses under a sewer, adequate structural support shall be provided for the sewer to prevent damage to the watermain.

## SECTION 02375 – PART III

### D. Unavailable Separation

1. When it is impossible to obtain proper horizontal and vertical separation as stipulated above, the sewer shall be either encased in concrete per the Standard Details or constructed using acceptable water pipe, ductile iron or PVC C-900, and pressure tested to assure water tightness. This shall apply to mainline sewers and lateral pipe.

2. If existing utilities are in conflict with the proposed separation distances, the Engineer may elect to modify the alignment and depth of the proposed sewer to attain compliance with standards.

### 3.05 BYPASS PUMPING

All bypass pumping necessary to maintain sanitary sewer service for the area shall be in accordance Section 01 57 20 Temporary Bypass Pumping. Sanitary sewer service shall be maintained at all times during the work.

### 3.06 SEWERLINE CLEANING TO FACILITATE CCTV

A. When directed by the Engineer, the Contractor shall provide all necessary labor, specialty equipment, water and other incidentals to effectively clean sanitary sewer lines of various diameters to facilitate CCTV. All sanitary sewer sections required to be lined shall be cleaned using mechanically powered, hydraulically propelled or high velocity sewer cleaning equipment. Selection of the equipment used shall be based on the conditions of the lines at the time the work commences. The equipment and methods selected shall be satisfactory to the Engineer. The equipment selected for cleaning shall be capable of removing dirt, grease, rocks, sand, tree roots and other deleterious materials and obstructions from the sewer lines and manholes.

B. All sewers shall be sufficiently cleaned and free of water as ordered by the Engineer, to permit internal television inspection of joints, and identify tap connections, cracks, leaks and breaks.

C. All sludge, dirt, sand, rocks, grease, tree roots and other solid or semi-solid material resulting from the cleaning operation shall be removed at the downstream manhole of the section being cleaned. Passing material from manhole section to manhole section, and/or washing materials downstream can cause line obstructions or blockages and will not be permitted. A collection device, as approved by the Engineer, shall be utilized to collect and remove debris from the reach being cleaned.

D. All dirt, debris, and other material removed from the sewers shall be hauled away and disposed of in a manner and place acceptable to the New York State Department of Environmental Conservation and the Engineer. All such work will be at the Contractor's expense. Under no circumstances will disposal of materials at Erie County Division Sewerage Management (DSM) facilities be permitted. The Contractor shall be responsible to secure their own



arrangements for waste hauling and disposal. Erie County DSM will co-sign third party authorization application forms as the waste generator. No waste generated from other sources shall be claimed as being generated from Erie County DSM sewers.

E. All materials shall be removed from the site at the end of each workday. Under no circumstances will be Contractor be allowed to accumulate debris, etc., on the work site beyond the stated time, except in totally enclosed containers meeting NYSDEC and OSHA requirements and as approved by the Engineer.

F. During all sewer cleaning operations, satisfactory precautions shall be taken to protect the sewer lines from damage that might be inflicted by the improper use of cleaning equipment. The cost of repair of any damage caused by the cleaning operation will be the responsibility of the Contractor. Whenever hydraulically propelled cleaning tools, which depend upon water pressure to provide their cleaning force, or any tools which retard the flow of water in the sewer line are used, precautions shall be taken to ensure that the water pressure created does not cause any damage or flooding to public or private property being served by the manhole section involved. The flow of sewage in the sewer lines shall be utilized to provide necessary pressures for hydraulic cleaning devices whenever possible. When additional quantities of water from fire hydrants are approved as necessary to avoid delay in normal working procedures the water shall be conserved and not used unnecessarily. No fire hydrant shall be obstructed in case of fire in the area served by the hydrant nor shall a hydrant be used for the purpose described unless the vacuum break is provided. The Contractor will be responsible for all permits, arrangements, and costs associated with obtaining water for this construction operation. The Contractor shall use approved backflow prevention devices if hydrants are used for water supply.

G. Contractor's personnel shall be familiar with all phases of sewer line cleaning to ensure quality performance without causing damage to any of the appurtenances associated with work involved. In the event a line must be re-cleaned as ordered by the Engineer for any reasons, the Contractor shall undertake such re-cleaning, without charge to the Owner.

I. Any damage caused by the Contractor's cleaning operation, shall be repaired by the Contractor at no additional cost to the Engineer or Owner.

## SECTION 02376 – SANITARY SEWER MANHOLES

### PART I – GENERAL

#### 1.01 SCOPE OF WORK

A. Furnish all labor, materials, equipment and incidentals required, and install in the locations shown on the Drawings, all sanitary sewer manholes as specified herein.

#### 1.02 RELATED WORK

A. Refer to Sections 02100, 02150, 02200, 02375, 02600, 02800 and 03300.

#### 1.03 SUBMITTALS

A. Shop drawings will be required for all fabricated and/or manufactured material items required by the specifications for this Section.

### PART II – PRODUCTS

#### 2.01 POURED IN PLACE BASES

A. The concrete base shall be 4000 psi concrete and the fill forming the invert channel shall be 4000 psi concrete as specified in Section 03300 of these Specifications and both shall be poured in the field.

#### 2.02 PRECAST BASES

A. The precast bases shall be monolithic reinforced concrete, and shall comply with the requirements specified in Section 02376-2.03 for manhole barrels, including gasket joints and approved joint compound.

B. The bottom or floor of the monolithic precast base shall have a minimum thickness of 8 inches, and shall project no less than 6 inches beyond the outside walls of the monolithic precast base to form a flange or annular footing intended to resist uplift.

C. The lowest edges of holes or cutouts for line and branch sewers shall be no less than six inches above the inside surface of the floor or footing of the monolithic precast base. The highest edges of holes or cutouts for line and branch sewers shall be no less than 6 inches from joint surfaces as detailed on the Plans. After installation of the line and branch sewers, manhole channels or inverts shall be formed by using 4000 psi fill concrete as specified in Seton 03300 of these Specifications.

D. At the point where the sewer line and branch sewers are connected to the monolithic precast bases or manhole barrels, the annular spaces between the pipes and holes shall

## SECTION 02376 – PART II

be sealed with assemblies consisting of rubber gaskets or links mechanically compressed to form watertight barriers. Such sealing assemblies shall be: RES-SEAL consisting of rubber gasket, cast iron compression flange; “Press-Wedge II” gasket or “Watertight Pipe to Manhole Rubber Boot Assemble” with stainless steel band clamps as manufactured by Press Seal Gasket Corporation, For Wayne, Indiana; Cor-Ten bolt assembly manufactured by the Scales Manufacturing Corporation of Newburgh, New York; LINK-SEAL consisting of solid synthetic rubber links connected to each other with heavy, elongated washers, bolts and nuts, as manufactured by the Thunderline Corporation of Wayne, Michigan, or equal. After installation, metal parts of the above assemblies that are accessible from inside the manholes shall be coated with compound as specified for manhole barrel joints.

E. All precast “Doghouse Style” base sections shall be installed on a 12” thick 4000 psi concrete footer pad. The pre-cast wall section shall be set 3” into the poured concrete base pad. After installation of the branch sewer(s), the existing sewer shall be cut with all interior manhole channels or inverts formed by using 4000 psi fill concrete as specified in Section 3300. The area of the cut out around the existing sewer pipe shall be sealed utilizing a hydrostatic non-shrink grout such as “Preco Patch”, “Waterplug” or approved equal.

F. The edges of holes or cutouts in riser or barrel sections for line and branch sewers shall be no less than 6 inches from joint surfaces, as detailed on the Plans.

### 2.03 SANITARY MANHOLE BARREL AND CONE

A. All precast manhole cones and barrels shall be constructed in accordance with the latest ASTM Specification C-478 “Precast Reinforced Concrete Manhole Sections”, with the following exceptions: The manhole barrel walls shall be five (5) inches thick for a four (4) foot diameter manhole, six (6) inches thick for a five (5) foot diameter manhole and seven (7) inches thick for a six (6) foot diameter manhole. The upper section of the precast manhole shall be an eccentric cone design having a 24 inch inside top opening diameter with an 8 inch (width) top bearing surface. Where the depth of the manhole is such that an eccentric cone section cannot be used a flat top section with a 24-inch opening shall be provided. The flat top slabs shall be a minimum of 8 inch thick and shall be capable of supporting a H-20 loading.

B. The Contractor shall submit to the Engineer for approval, details of manhole barrels and cones that he proposes to use. Precast cones shall have a minimum height of two feet, six inches (2’-6”) and a maximum height of four (4) feet as shown on the Plans. No penetrating lifting holes will be allowed.

C. The precast bases and manhole barrel sections will be required to be vacuum factory testing in job lots per the following schedule. Factory vacuum tests shall be performed on linear footage of manhole barrel job lots as follows:

First test for jobs requiring from 8 ft. to 100 ft. of manholes.

Second test shall be performed on 101 ft. to 300 ft. lots

SECTION 02376 – PART II

Third test shall be performed on 301 ft. to 600 ft. lots  
Fourth test shall be performed on 601 ft. to 1,000 ft. lots  
Fifth test shall be performed on lots over 1,001 ft.

D. Installation and operation of vacuum equipment and indicating devices shall be in accordance with the manufacturer’s recommendations and instructions. A test vacuum of 10 inches of mercury shall be drawn. The time for the vacuum to drop to 9 inches of mercury shall be recorded. Acceptance for 4 foot diameter manholes shall be defined as when the time to drop to 9 inches of mercury meets or exceeds the following:

<u>Manhole Depth</u>	<u>Diameter</u>	<u>Time to Drop 1” Hg.</u>
10 feet or less	4’	60 seconds
10 feet to 15 feet	4’	75 seconds
15 feet to 30 feet	4’	90 seconds

For manholes 5’ in diameter, add an additional 15 seconds and for manholes 6’ in diameter, add an additional 30 seconds to the time requirements for 4’ diameter manholes.

If the manhole fails the test, necessary repairs shall be made and the vacuum test repeated until the manholes passes the test.

2.04 JOINTS

A. The manhole barrel and cone joints shall be concrete with a confined “O” ring, neoprene gasket in accordance with the latest ASTM Specification C-443. The manhole supplier will be required to vacuum test the manhole joint in the factory in the job lots as described in 2.03, all in accordance with the latest ASTM Specification C-443 at a test pressure of 13 psi. The joint test may be performed at the same time as the vacuum test which is described previously in Section 01276-2.03 (D). The factory joint test shall be conducted without the joint compound specified below.

B. In addition to the neoprene gasket, each joint shall be buttered prior to assembly with an approved joint compound such as “Dewitt’s No. 10”, Duralseal 3101, Pioneer 301, or equal compound. The excess shall be removed from the inside and some excess shall be troweled on the outside. The inside joints shall be troweled with “Preco-Patch,” or equal.

2.05 ADJUSTING RINGS

A. Grade rings shall not exceed 6 inches in depth. The total number of grade rings shall not exceed 12 inches in height. However, no more than three (3) grade rings will be allowed to be installed. The adjusting ring joints shall be made with an approved cement mortar.

SECTION 02376 – PART II

The outside of the adjusting rings from casting to cone shall be coated with an approved "Preco-Patch", Rock Mount, "Waterplug", or equal.

#### 2.06 MANHOLE STEPS

A. Manhole steps shall be forged aluminum alloy, as detailed on the Plans, or steel reinforced co-polymer polypropylene, and shall be placed in the forms while the manhole barrel and cone sections are being cast or securely grouted in place after casting.

#### 2.07 MANHOLE FRAMES AND COVER

A. Manhole frames and covers shall be gray iron castings, as detailed on the Plans. The lid shall be lettered "E.C.S.D. SANITARY" and drilled with four (4) ¾ inch diameter vent holes as shown on the Plans/Details. Manhole rims shall be set above the adjacent ground level as required. Some manhole covers shall have a locking device as detailed on the plans and shall be furnished with pentagon bolts. Manufacturer's drawings of all castings which the Contractor proposes to use shall be submitted to the Engineer and approved by him prior to the castings being orders for the work. No commercial "Brand Name" lettering will be allowed on the exposed surface of the cover.

B. Watertight frames and covers shall be gray iron castings as detailed on the Plans. Manufacturer's drawings of all castings which the Contractor proposes to use shall be submitted to the Engineer and approved by him prior to the castings being ordered for the work. Watertight frames shall be anchored to the manhole cone section or top slab by a minimum of six (6) ½ inch anchor bolts.

#### 2.08 DROP PIPES

##### Inside Drop Pipe

Inside drop pipes and fittings shall be PVC plastic sewer pipe in compliance with the latest ATM Specification D-2241. Fittings shall be rigid, elastomeric gasket and of the same material as the drop pipe. Suitable unions or adapters shall be provided to connect to other types of piping where necessary. Suitable spacers and anchors shall be provided to adequately attach the drop pipe along the inside of the manhole barrel wall. An acceptable alternative is a "drop bowl" style suitable for installation in a sanitary sewer environment and constructed of marine grade fiberglass with 304 stainless steel clamping pipe supports.

#### 2.09 VENT STACKS

The vent stack shall consist of 4-inch diameter plain end welded steel pipe coated with two coats of green epoxy paint, including heavy duty perforated bird screen, required fittings and 4000 psi concrete, all as detailed on the Plans.

SECTION 02376 – PART III

PART III – EXECUTION

3.01 INSTALLATION

A. Excavation and backfilling shall be done in accordance with the requirements of Section 02200. Temporary sheeting shall be done in accordance with the requirements of Section 02250.

B. The concrete for poured in place bases shall reach a 4000 pounds per square inch minimum compressive strength at 28 days. A minimum of three (3) test cylinders shall be taken for the base pour. One cylinder shall be tested at 7 days, one at 28 days, and one spare. Two copies of the test reports shall be submitted to the Engineer within 5 days of testing, which will be done in accordance with the latest ASME Standards. Cost of testing shall be at Contractor's expense.

C. All manholes and drop manholes shall be set on 6" of No. 1 Crushed Stone compacted to proper elevation.

D. Backfill around pipes at manholes shall be carefully tamped.

3.02 SANITARY MANHOLE TESTING

1. After backfilling and prior to the final acceptance of the project, the Contractor will be required to perform an Infiltration or Exfiltration test on all manholes constructed under this project. The Contractor will be responsible for all labor and equipment costs necessary to complete the test. Also, the Contractor's testing procedures shall be completed in accordance with OSHA Standards for confined space entry. The Contractor will be required to provide and operate all equipment necessary for full compliance with the OSHA Standards. Equipment such as gas detector, safety harnesses, ventilating blowers, respirators, etc., shall be provided by the Contractor.

2. Before the start of any testing, the ground water table should be allowed to stabilize to its normal level. The Engineer will evaluate the elevation of the ground water to determine if an infiltration or exfiltration test shall be conducted. The Contractor will be required to proceed on the Engineer's final determination. It should be noted that the selected test procedure may vary from manhole to manhole, as it is dependent on the ground water elevation.

3. In areas with a high ground water condition, the Engineer may order infiltration tests for manholes. Where such tests are ordered, the maximum allowable infiltration shall not exceed 100 gallons per inch of internal diameter pipe mile of length per day. Subject to the approval of the Engineer, the testing of the manhole structures can be completed with the testing of the installed sanitary sewer pipe.

SECTION 02376 – PART III

4. In areas with a low ground water elevations, the Engineer may order the Contractor to complete a hydrostatic exfiltration test on the manholes. The manholes being hydrostatically tested shall be filled with water from the invert to a point 12 inches above the joint that connects the last manhole barrel section to the top cone section. Maximum exfiltration shall not exceed 100 gallons per inch of internal diameter per mile of barrel length per day. In lieu of the hydrostatic exfiltration test, the Contractor, subject to the approval of the Engineer, may complete a vacuum test on the manholes.

5. In the case of a vacuum test, the Contractor will be required to follow the manufacturer's recommendation and instructions with respect to the installation and operation of vacuum equipment and the indicating devices. A test vacuum of 10 inches of mercury shall be drawn. The time for vacuum to drop to 9 inches of mercury shall be recorded. Acceptance of 4 foot diameter manholes shall be defined as when the time to drop to 9 inches of mercury meets or exceeds the following:

<u>Manhole Depth</u>	<u>Diameter</u>	<u>Time to Drop 1" Hg.</u>
10 feet or less	4'	60 seconds
10 feet to 15 feet	4'	75 seconds
15 feet to 30 feet	4'	90 seconds

For manholes 5" in diameter, an addition 15 seconds shall be added to the above listed test cycle times. For manholes 6' in diameter, an additional 30 seconds shall be added to the above listed time requirements for 4' diameter manholes.

6. If any manhole fails its test, the Contractor will be required to make the necessary repairs subject to the approval of the Engineer and the test shall be repeated until the manhole passes the test. The Contractor, at his own expense, shall also repair any leaks discovered after testing and/or during the one-year maintenance period.

## SECTION 02600 – PAVING AND SURFACING

### PART I – GENERAL

#### 1.01 SCOPE OF WORK

A. The Contractor shall furnish and install all paving and surfacing as shown on the Plans and specified herein, and dispose of all excess material.

1. All existing blacktop paved roads which are removed or damaged during the construction shall be repaired and resurfaced.

2. Work under this Section shall not begin until the backfill has been compacted in accordance with Section 02200 of these Specifications and accepted by the Engineer.

3. Final surfacing of bituminous pavements and walks, or pouring of concrete pavements and walks, shall not be performed until all excavation and backfilling which could affect the work has been completed and the heavy construction equipment is no longer required to traverse the areas of proposed pavements and walks.

4. All permits necessary from the Village, Town, County or State Highway Departments shall be obtained and paid for by the Contractor. The terms of the permit shall be adhered to as if they were a part of these Specifications.

### PART II – PRODUCTS

#### 2.01 MATERIALS

##### A. Bituminous Macadam Pavement and Driveways

1. Unless otherwise specified herein, all bituminous macadam materials and work shall conform to the applicable requirements of the New York State Department of Transportation “Standard Specifications”, latest Edition.

- a. 9.5 F2 Top - NYSDOT Item No. 402.098204, 80 Series
- b. 19 F9 Binder – NYSDOT No. 402.198904, 80 Series
- c. 37.5 F9 Base – NYSDOT No. 402.378904, 80 Series

##### B. Crushed Stone Road, Driveways and Parking Areas

1. To match existing conditions or as directed, restoration of crushed stone roads, driveways or parking areas, shall be with Select Granular Fill materials in Section 02200. Road materials shall be approved, well-graded crushed gravel or well-graded crusher run stone. To match existing conditions or as directed, finish topping material for stone roads, driveways and parking areas shall be No. 1A or No. 1 crushed gravel or stone as directed and approved by the Engineer.



## SECTION 02600 – PART II

### C. Concrete Road Base

1. Concrete base shall be constructed of NYSDOT Standard Specifications NYSDOT Item No. 503.0101.
2. Reinforcement shall be dowels 5/8" diameter x 1'-6" long, 3'-0" on center smooth Grade 60 NYSDOT Item No. 556.0201.

### D. Concrete Sidewalks

1. Sidewalks shall be constructed of 4000 psi concrete as specified in Division 3, Section 03310-2.05.

### E. Concrete Road and Driveways

1. Roads and driveways shall be constructed of 4000 psi reinforced concrete as specified in Division 3, Section 03310-2.05.
2. Reinforcement shall be welded wire fabric weighing not less than 65 lbs. per 100 square feet with wires equally spaced in each direction, and conforming to the requirements of Division 3, Section 03200, or as directed by the Engineer.

## PART III – EXECUTION

### 3.01 PREPARATION

#### A. Sub-grade Preparation

1. After backfilling and grading is completed, the sub-grade shall be shaped and compacted to an even, firm foundation. All unsuitable sub-grade materials, including soft materials, boulders, vegetation and loose stones shall be removed and replaced with well compacted foundation material.

### 3.02 INSTALLATION

#### A. New Asphalt Pavement

1. The Contractor shall construct to extents shown in the Work Order, the minimum compacted depth pavement per the Standard Details or to match the existing pavement component thickness.
2. The Contractor shall excavate and remove material to the extents shown in the Work Order and install geotextile fabric where required by the roadway owner and minimum depth of compacted type 2 stone subbase course.

3. Over this prepared subbase course and tack coat, where required by the roadway owner, construct an asphalt concrete, consisting of minimum 4 inches (4") base course, according to the New York State Department of Transportation Specifications, section 402.

3. Over this prepared subbase or base course and tack coat, construct an asphalt concrete, consisting of 2 inches (2") of binder and 1.5 inches (1.5") top course, according to the New York State Department of Transportation Specifications, section 402.

4. Where existing bituminous pavements or driveways are necessarily required to be cut, the width of pavement required to be removed is shown on the Plans. If the Contractor should remove pavement beyond the Pay Limits shown, he shall replace same at his own expense.

5. All work affecting paved roads, streets or highways shall be done in a manner satisfactory to the authority having jurisdiction over the particular pavement.

6. After the roadway areas are completed, the Contractor shall string lines along the edges of the pavement and shall trim the edges as required by the Engineer to give a neat edge appearance to the road construction.

7. Slope all roadway area as shown on the Drawings to catch basins so that there are no low spots where water will collect.

8. In general, the new pavement shall be graded to drain as shown on the Drawings. Where new paving work meets existing paving, care shall be taken to provide a neat and smooth transition in a neat and workmanlike manner.

#### C. Crushed Stone Roadway, Parking Area and Driveway

1. Upon the prepared subgrade, the roadway, driveway or parking area materials shall be placed and compacted to the lines, grades and thickness specified, or as determined by field conditions and ordered in writing by the Engineer.

2. Roadways shall be constructed in two courses or lifts. The maximum subgrade thickness shall be not less than eight (8) inches and a top course thickness of not less than four (4) inches. After the courses are thoroughly compacted, No. 1 stone and screenings shall be uniformly spread, either by hand or by an approved mechanical device, upon the surface and swept in by means of a gang-dragged broom of an approved type and rolled dry.

#### D. Concrete Road Base

1. Where there is an existing concrete roadbase, it shall be replaced to match existing thickness unless an alternative material is approved in writing by the roadway owner. Dowel into existing concrete at minimum 3'-0" on center and install dowels in accordance with NYSDOT Standard Specifications, Section 503.

SECTION 02600 – PART III

E. Concrete Sidewalks

1. Foundation

The concrete sidewalks shall be constructed on a four (4) inch compacted stone or gravel foundation course.

2. Forms

Sidewalk forms are to be set upon the foundation course; the top of the form conforming with the walk grade. Forms shall be steel, 4 inches in height or 6 inches in height when traversing driveways and of such length and shapes as may be required to form the required walks. All inside faces shall be clean and smooth, and shall be oiled before the concrete is placed. Forms shall be held in place with pins, or other devices so that during the construction of the walk a straight and even edge shall be maintained.

3. Joints

Sidewalks shall be built with transverse construction joints 5 feet apart or as directed. Joints shall be cut through the slab. Expansion joints ½ inch in width must be cut through the slab to the foundation every 20 feet or fraction thereof and filled with a bituminous expansion joint.

4. Wire Fabric Reinforcement

Wire fabric (6x6x10 ga.) shall be used in the 6-inch thick sidewalks traversing driveways. The wire fabric shall be placed at the mid-depth point of the slab supported on wire chairs and lapped as required.

5. Placing and Finishing Concrete

After the foundation course has been satisfactorily prepared and after the approved forms are in place to grade, and the same has been checked and approved by the Engineer, the Contractor shall proceed to place the concrete. Concrete of 4000 psi shall be placed to the full depth of the form, carefully spaded, and placed to form a uniform and dense mixture, and leveled off with a template to a smooth surface level with the top of the forms. The surface shall be finished with a float and troweled by skilled workmen. After the surface has been leveled and finished and before the concrete takes its final set, the surface shall be evenly stroked with a broom to give a slightly rough and uniform finish.

6. Curing

After concrete is placed and finished, it shall be protected by applying an approved colorless curing compound. This compound shall be applied by pressure spraying at a

## SECTION 02600 – PART III

rate of not less than 1/30 of a gallon per square yard. In lieu of the spraying compound, a covering may be used which meets with the approval of the Engineer.

### 7. Protecting Work

When the concrete work is finished, the Contractor shall protect the same from the weather, trespasses, or other injurious elements for at least three days, and until the concrete has received a final set. The forms shall remain in place during this curing period. Work placed during cold weather shall be covered.

### E. Concrete Driveways

#### 1. Foundation

The concrete driveways shall be constructed on a six (6) inch compacted stone or gravel foundation course.

#### 2. Forms

Driveway forms are to be set upon the foundation course; the top of the form conforming with the driveway grade. Forms shall be steel, 6 inches in height and of such lengths and shapes as may be required to form the required driveways. All inside faces shall be clean and smooth, and shall be oiled before the concrete is placed. Forms shall be held in place with pins, or other devices so that during the construction of the driveway a straight and even edge shall be maintained.

#### 3. Joints

Driveways shall be build with transverse construction joints 10 feet apart or as directed. Joints shall be cut through the slab. Expansion joints ½ inch in width must be cut through the slab to the foundation every 20 feet or fraction thereof and filled with a bituminous expansion joint.

#### 4. Wire Fabric Reinforcement

Same as specified for Section 02600-3.02 D-4.

#### 5. Placing and Finishing Concrete

Same as specified for Section 02600-3.02 D-5.

#### 6. Curing

Same as specified for Section 02600-3.02 D-6.

## SECTION 02620 – CURBING

### PART I – GENERAL

#### 1.01 SCOPE OF WORK

A. Where existing concrete curbing is necessarily required to be removed, whole sections of the curbing (from joint to joint) shall be removed, and voids filled with poured-in-place concrete curb of the dimensions and shape to match the existing curb. The reconstruction of the curb shall include the necessary porous fill and drain pipe which form the curb structure.

B. Where existing granite curbing is necessarily required to be removed, whole sections of the curbing (from expansion joint to expansion joint) shall be removed and, if possible, reinstalled; or voids filled with new granite curbing of the dimensions, shape, and type to match the existing curb. The reconstruction of the curb shall include the necessary porous fill, concrete foundation, and drain pipe which form the curb structure.

C. Where existing curb ramps requires replacement, new curb ramps shall be in accordance with the Americans with Disabilities Act (ADA), NYSDOT Standards, and the requirements of the roadway owner.

D. All required permits shall be obtained at the expense of the Contractor and the terms of these permits adhered to as part of these Specifications.

### PART II – PRODUCTS

#### 2.01 MATERIALS

##### A. Concrete

1. Refer to Section 03300

##### B. Granite

1. Granite curbing shall be installed and of the types outlined in New York State Department of Transportation Specification No. 609, Latest Edition.

##### C. Porous Fill

1. Porous fill material under the curbing shall be minimum  $\frac{3}{4}$ " diameter broken stone, screened to remove excess fine materials. A sheet of tar paper or similar material shall be placed over the fill, upon which the concrete masonry shall be installed.

##### D. Underdrain Pipe

1. The curbing underdrain pipe shall be 4 inch or 6-inch perforated plastic pipe or of the size and type of the existing underdrain.

## SECTION 02620 – PART III

### E. Expansion Joints

1. Refer to Section 03300 for pre-molded bitumastic type joints, to be utilized for both concrete and granite curb replacement.

## PART III – EXECUTION

### 3.01 INSTALLATION

#### A. Preparation

The existing curbing, having been previously removed by other phases of the project, shall be replaced in kind. The Contractor shall determine the existing size, shape and type of curbing, and the existence of curb under drain piping. A trench shall be prepared of adequate width and depth to accommodate the porous fill material.

#### B. Porous Fill

The stone fill material shall be placed so that all areas of both the new and existing curbing will be adequately supported. The top elevation of the placed stone shall be controlled so that the proper curb cross-section can be maintained. The stone shall be covered with a layer of tar paper or equal material to the full width of the new curbing so that concrete cannot fill the voids in the porous fill material.

#### C. Underdrain Pipe

The plastic underdrain pipe shall be laid to grade and properly bedded in the porous stone material. The pipe shall be connected to the curb receivers, storm manhole, or other drainage pipe or structure as required.

#### D. Expansion Joints

At 20 foot intervals, at the end of a day's run and/or adjacent to catch basins or receivers, a ¾" expansion joint of pre-molded bitumastic material shall be installed.

#### E. Curb Ramps

Where curb ramps require replacement, new curb ramps shall be in accordance with the Americans with Disabilities Act (ADA) and NYSDOT Standard Sheets 608-01.

## SECTION 02800 – RESTORATION

### PART I – GENERAL

#### 1.01 SCOPE OF WORK

##### A. Related Documents

1. The general provisions of the contract, including general and special conditions, apply to the work specified in this Section.
2. Refer to Section 02810, Sodding and Section 02820, Hydroseeding.

##### B. Description of Work

1. Under the work of restoration the Contractor shall prepare the soil and apply topsoil on unpaved areas, including field areas furnish and apply grass seed, furnish and plant trees and shrubs, furnish and apply gravel on stipulated areas and maintain lawns and plantings for the specified periods, all as required and specified.

#### 1.02 QUALITY GUARANTEE

##### A. Scheduling Seeding

1. Seeding shall be permitted only between April 15 and May 30 for spring seeding and August 15 and September 15 for fall seeding. No seeding shall be done during high winds or when the ground surface is too wet for proper working.
2. Unless otherwise directed by the Engineer, deciduous material shall be planted from March 1 to May 1 and from October 15 to December 1. Evergreen material shall be planted from April 1 to May 15 and from September 1 to October 15.

##### B. Plant Guarantee

1. All plants shall be guaranteed for one year or for the duration of one full growing season, beginning after the last planting is complete. At the end of the guarantee period, any dead, unhealthy or badly impaired plants shall be replaced. All replacements shall be plants of the same kind and size. The cost of such replacement shall be borne by the Contractor. Replacements shall be guaranteed for one year after replanting.

#### 1.03 DELIVERY, STORAGE AND HANDLING

- A. Deliver grass seed in original containers showing analysis of seed mixture, percentage of pure seed, year of production, net weight, date of packaging and location of packaging. Damaged packages are not acceptable.

SECTION 02800 – PART I

B. Deliver fertilizer in waterproof containers or bags showing weight, chemical analysis and name of manufacturer. Federal regulations governing handling and storage of fertilizer must be followed.

PART II – PRODUCTS

2.01 MATERIALS

A. Topsoil

1. Topsoil shall consist of friable, natural earth of loamy character, without admixture of subsoil, uniform in quality and free to refuse of any nature, hard clods, still clay sods, hard pan, pebbles larger than ¼ inch in diameter, coarse sand, noxious weeds, sticks, brush and other rubbish.

2. When specified, topsoil for backfilling plant pits and planting areas shall be mixed with well-rotted manure in the following proportions:

a. Seven cubic yards of topsoil to 1 cubic yard of manure shall be thoroughly mixed by placing the manure evenly over the topsoil piles and turning the piles at least 3 times or until thoroughly mixed to the satisfaction of the Engineer. The volume of manure will not be considered in the measurement of topsoil.

3. Manure shall be well-rotten horse or cow manure or a combination thereof. It shall contain not over 40 percent of straw or litter and shall be free from fresh manure, sawdust, wood chips, leather hips, tan-bark, long straw, salt hay, stones or chemicals used to hasten decomposition artificially and other foreign or injurious substances.

B. Grass Seed for Lawn Areas

1. Seed shall be fresh, clean, new crop seed composed to the following varieties mixed in the proportions by weight as shown, and testing the minimum percentage of purity and germination indicated:

<u>Name</u>	<u>By Weight</u>	<u>Proportion</u>	
		<u>Purity</u>	<u>Germination</u>
Perennial Manhattan Ryegrass	40%	98%	90%
Kentucky Blue Grass	25%	85%	90%
Annual Ryegrass	20%	95%	90%
Red Fescue-Creeping	15%	95%	90%

2. Special seed mixes may be needed for shady areas or unusually dry areas. Follow recommendation of reputable seed supplier or nurseryman.

SECTION 02800 – PART II



C. Grass Seed for Field Areas

1. Seed shall be fresh, clean, new crop seed composed to the following varieties mixed in the proportions by weight as shown, and testing the minimum percentage of purity and germination indicated:

<u>Name</u>	<u>By Weight</u>	<u>Proportion Purity</u>	<u>Germination</u>
Perennial Ryegrass Manhattan or Perofine (Lolium Perenne)	50%	98%	85%
Annual Ryegrass	50%	95%	90%

D. Fertilizer

1. Fertilizer shall be mixed, of commercial quality, with a N-P-K ratio equal to 17-23-6 and 50% of the elements derived from organic sources.

E. Peatmoss

1. Peatmoss shall be horticultural grade Class A decomposed plant material; elastic and homogeneous; free of decomposed wood, sulfur, and iron; PH value of 5.9-7.0; 60% organic matter by weight; and a moisture content not exceed 15%.

F. Gravel

1. Gravel shall be washed bank gravel or river gravel ranging in size from approximately ½ inch up to and including 1 ¼ inch.

G. Steel Edging and Stakes

1. Steel edging shall be made from high grade open hearth, heavy steel strip ½ inch thick by 5 inches wide. Each section of edging shall have pockets or slots pressed into them for the insertion of tapered steel stakes at intervals of 2 feet.

2. Stakes shall be fabricated of the same material as the edging and shall be ½ inch by 1 ½ inch at the top tapering to ½ inch wide at the bottom by 18 inches long.

H. Trees and Shrubs

1. Plant names shall agree with the nomenclature of "Standard Plant Names" as adopted by the American Joint Committee on Horticultural Nomenclature latest edition. Size and grading standards shall conform to those of the American Association of Nurserymen unless otherwise specified.

SECTION 02800 – PART II

2. All trees and shrubs shall be nursery grown, at least twice transplanted, and shall have a fully developed fibrous root system typical of the stated species. All trees shall be freshly dug, and if so specified, balled and burlapped immediately before shipping. Trees and shrubs from storage or those not freshly dug will not be accepted.

3. All trees and shrubs shall be true to name, and no substitution in species or varieties will be accepted. The vendor shall label plainly all trees and shrubs with a metal label and shall state the botanical name and size of the respective species on each label. The labels shall be attached firmly and be of such nature as to be permanently legible.

4. All trees shall meet the trunk size designated on the Plans, measured one foot above the ground. Where spread size is designated, limbs shall radiate to the specified diameter to complete the full periphery or circumference measured axially through the tree trunk so as to form a top substantially uniform in weight and density all the way around and typical of the species specified.

5. On trees designated “balled and burlapped” the ball must meet the diameter specified at the top of the ball and the diameter at the bottom of the ball shall vary not less than 20 percent of the top. The top surface and bottom surface of the ball must be parallel. The ball depth specified must be met at all points perpendicular to the bottom diameter of the ball. (Ball, as used in this specification, connotes the frustrum of a cone.)

6. All shrubs must fulfill dimensional requirements designated in the plant list or on the Plans and must be heavily chained and typical of the stated species.

7. The tree replacement schedule for those trees marked with an “R” on the plans is as follows:

- a. For trees less than or equal to 3 inches in diameter, provide new trees of same sizes and species as those replaced.
- b. For trees greater than 3 inches in diameter but less than or equal to 8 inches in diameter, provide one (1) 3-inch in diameter tree of same species as those replaced.
- c. For trees greater than 8 inches in diameter, provide two (2) 3 inch in diameter trees of same species as those replaced.
- d. For trees marked on the plans to be protected or tunneled (T), the Contractor shall provide subsurface tree protection in accordance with the Drawings and as specified herein or as otherwise directed by the Engineer.

## SECTION 02800 – PART II

### I. Miscellaneous Materials

1. Bracing stakes shall be of white cedar, chestnut, or other approved wood. Surface stakes shall measure two inches by four inches for trees braced with three stakes and two inches for trees braced with two stakes. Underground deadman shall be at least four inches by four inches by four feet long. All stakes shall be free from insects and fungi.
2. Wire shall be galvanized steel wire, No. 12 A.S. & W. gauge throughout.
3. Hose shall be fiber centered remnants or suitable second hand material of one inch, five-eighths inch or three-quarter inch diameter weighing approximately one-half pound per linear foot, or other suitable material.
4. Jute burlap shall weigh eight ounces per square yard.
5. Material used in wrapping trees shall be jute twine not less than two ply for trees three inches or less in diameter and three ply for trees over three inches in diameter.

## PART III – EXECUTION

### 3.01 INSTALLATION

#### A. SOIL PREPARATION

1. Topsoil shall be placed on unpaved areas to the limits as shown on the Plans. Seeding, sodding, trees and shrubs shall be furnished, planted and maintained as shown, specified and ordered. Topsoil shall be placed to a minimum depth of 6 inches (as measured after rolling and compaction).
2. Additional topsoil shall be provided in tree and planting areas as required to provide a depth no less than the planting hole depth as herein specified.
3. All topsoil, after uniform grading, shall be thoroughly rolled to provide maximum compaction.
4. After placing the topsoil, the area shall be raked and all stones, rocks, and weeds removed. A suitable commercial fertilizer shall then be evenly applied over the area, at a rate recommended by the manufacturer, and thoroughly raked in.

#### B. SEEDING

1. After the topsoil has been spread and the final grades established in accordance with the Contract Specifications, the entire area shall be fine graded by discing or

SECTION 02800 – PART III

tilling to a depth of four inches. After discing or tilling, the area shall be dragged with a plant float so as to develop a smooth, even surface. Power equipment may be used, but in areas that are too small for power equipment to operate, the above operations shall be done with the use of hand tools.

2. Grass seed shall be sown in two operations and at right angles to each other at the rate of two pounds per thousand square feet in each operation.

3. After the sowing of the seed, the area shall be lightly raked or dragged, and then rolled with a 200 pound roller.

4. After the raking and rolling operations are completed the entire seeding area shall be watered with a fine spray until a uniform moisture depth of 1 inch has been obtained.

5. Wooded and field areas shall be seeded with perennial rye grass at the rate of 100 lbs. per acre.

C. GRAVEL

1. Gravel shall be placed in the areas as shown on the Contract Drawings and to the grades, thickness and elevations as indicated. The surface shall be left smooth and even.

2. Provide steel edging to separate all gravel beds from lawn or planting areas.

D. STEEL GRAVEL EDGING

1. The edging shall be placed as required to form a sharp straight edge between the gravel area and the planting area. The steel edge shall extend approximately ½ inch above the general ground surface.

E. DIGGING FOR TREES AND SHRUBS

1. The Contractor shall excavate all plant pits and shall furnish plant, dig, transplant, maintain and replace all plant material as directed by the Engineer.

2. In digging the trees and shrubs with a root ball, minimum lateral diameter of the root ball shall be specified. The root ball shall be of sufficient depth to include all lateral roots. All fibrous and pliable roots encountered in trenching around the ball shall be cut off flush with the outer side of the trench, the ground in the trench loosened with a spading fork, and the flexible roots wrapped against the side of the ball. The root ball shall be firm and compact, tightly and adequately bound with burlap wrapping and tied with a good grade of hay rope or

### SECTION 02800 – PART III

heavy twine. Under no circumstances shall the root ball be artificially manufactured to meet size requirements, and none will be accepted in a loose, broken or lopsided condition.

3. All trees and shrubs require to be moved with ball and burlap will be measured across the minimum lateral diameter of the root ball.

4. All trees and shrubs required to be dug bare root shall have all the fine fibrous roots preserved. After digging, the bare root plants shall be puddle in a heavy mixture of clay mud, and kept in a moist, but not frozen, condition until planted.

5. Diameter of pits for trees balled and platformed shall be at least two feet greater than the diameter of the ball or spread or roots. Depth of pits for balled and platformed trees shall be six inches deeper than the depth of the ball, or depth of roots. In no case shall it be less than two feet deep.

6. Diameter of pits for bailed and burlapped trees and shrubs shall be at least eighteen inches greater than the diameter of the ball. Depth of pits for balled and burlapped areas shall be six inches deeper than the depth of the ball.

7. Diameter of pits for bare root trees and shrubs shall be at least one foot greater than the diameter of the spreads of roots. Depth of pits for bare root trees and shrubs shall be six inches deeper than the root system.

8. Larger pits may be required. The areas where ground cover plants or annuals are to be placed shall be Rito-tilled at least 4 inches deep.

#### F. SETTING PLANTS

1. All trees and shrubs shall be set at such level that after settlement, they bear the same relation to the elevation of the surrounding ground as they bore to the ground from which they were dug. All trees and shrubs shall be backfilled with topsoil. Topsoil shall be thoroughly and properly settled by tamping and watering.

2. Balled plants shall be backfilled with topsoil carefully tamped around and under the base of each ball to fill voids. Platforms shall be removed. All burlap, ropes, etc. shall be removed from the tops of the balls but no burlap or wrapping shall be pulled out from under the balls.

3. Bare root plants shall be properly spread out in a natural position and topsoil shall be worked in among them by watering. All broken and frayed roots shall be cleanly cut off.

4. Ground cover plants, annuals and hedges shall be spaced as directed at the time of planting.

SECTION 02800 – PART III

G. GUYING AND STAKING

1. Each tree over 2 ½ inches and less than 6 inches caliper shall be firmly anchored after planting by means of three guys, each of two strands of wire anchored to stakes. The stakes shall be two inches by four inches by four feet long and shall be driven 18 inches below the ground at an angle away from the tree.
2. Trees over six inch caliper shall be guyed with deadman and four strands of wire. Deadman shall be buried thirty inches below ground and have 2 inch square by 24 inches long stakes driven at an angle between the tree and the deadman.
3. All trees less than 2 ½ inch caliper shall be anchored by means of two stakes, two inches square by ten feet long, driven into the ground at least two feet and located at a distance of eight inches from the trunk of the tree. Two strands of wire shall be used to secure the tree to the stakes.
4. All guy wires shall be attached to the tree trunk above substantial limbs, one inch diameter or over if possible. The tree trunk shall be protected by a covering of heavy garden hose on the wires at every point of contact with the trees. All guy wires shall be maintained tight by the Contractor for the duration of the Contract.

H. WATER AND MULCH

1. A shallow saucer, capable of holding water shall be formed about each tree and shrub by placing a mound of topsoil around the ends of each pit. The ring shall be made by building a level dam of earth six inches high above the highest point of the ball and graded gradually into the adjacent grades.
2. The well around each plant shall be filled to a depth of two inches with a peat moss mulch.
3. The soil around each plant shall be thoroughly saturated with water at the time of planting, and as many times later as seasonable conditions require for the entire maintenance period.

I. SPRAYING WITH ANTI-DESICCANT

1. The Contractor shall spray all plant material with an anti-desiccant, using an approved power sprayer to apply an adequate film over trunks, branches, twigs and/or foliage, as directed by the Engineer. The anti-desiccant shall be emulsion which will provide a protective film over plant surfaces, permeable enough to permit transpiration.

SECTION 02800 – PART III

J. WRAPPING

1. Trees of two inch caliper and up shall be wrapped with a 6 inch new plain burlap bandage securely tied at the top and bottom and at 2 foot intervals along the trunk. The bandages shall cover the entire surface of the trunk to the height of the first branches. Bandaging shall be started at base of tree. Burlap bandages shall be maintained in place.

3.02 MAINTENANCE

A. MAINTENANCE OF SEEDED AREAS

1. Maintenance of seeded areas shall consist of watering, weeding, cutting and trimming the grass, and performing any other necessary work incidental to the establishment of a good stand of grass reasonably free of weed or other obnoxious grasses.

2. The maintenance period shall begin immediately upon the completion of the seeding operations and shall continue for a period of not less than forty-five days, or until the grass has been cut twice, and if necessary at the direction of the Engineer, until an acceptable stand of grass has been established.

B. GENERAL MAINTENANCE

The Contractor shall confine his operations to the immediate trench area and exercise reasonable and normal precautions in the work, particularly in the use of equipment, so as to prevent damage occurring as a result of the work. All damage will be replaced or repaired by the Contractor at his expense.

If, during the course of work, a dust hazard is created, the Contractor shall install, maintain and effectively operate such equipment and methods as required for the elimination of harmful dust during the life of this contract; and in case of failure of compliance of the Contractor as provided by Section 222-a of the Labor Law, his contract shall be void.

When directed by the Engineer, the Contractor shall spray water where directed and in such quantities and at such frequencies as may be required to control such dust and prevent it from becoming a nuisance to the surrounding areas at no additional cost to the Owner.

## SECTION 02810 – SODDING

### PART I – GENERAL

#### 1.01 SCOPE OF WORK

A. Sodding may be performed in lieu of the specified grass seeding of Section 02800 with the approval of the Engineer.

B. The Contractor shall prepare the soil and apply topsoil on unpaved areas, furnish and apply grass sod, and maintain sod for the specified periods, all as required and specified.

#### 1.02 RELATED WORK SPECIFIED ELSEWHERE

A. Refer to Section 02200, Earthwork and Section 02800, Restoration.

#### 1.03 REFERENCE STANDARDS

A. ASPA (American Sod Producers Association), Guideline Specifications to Sodding.

### PART II – PRODUCTS

#### 2.01 MATERIALS

A. Sod

Sod shall be two year old nursery grown sod of Kentucky Blue Grass, well rooted and free from weeds and other objectionable plants. The grass shall be cut to a length approximately two inches immediately prior to cutting the sod. The sod shall be cut to a thickness of not less than  $\frac{3}{4}$  inch or more than  $1\frac{3}{4}$  inches.

B. Topsoil - Refer to Section 02800

C. Fertilizer - Refer to Section 02800

### PART III – EXECUTION

#### 3.01 INSTALLATION

A. Soil Preparation

1. Refer to Section 02800 for information regarding topsoil placement. Topsoil depth of 6" to be adjusted to allow for thickness of the sod to maintain final elevations required.



## SECTION 02810 – PART III

### B. Laying Sod

1. After the topsoil has been spread and the final grade established in accordance with the Contract Specifications and the Contract Drawings, the area to be sodded shall be fine graded by discing the tilling to a depth of 5± inches. Following the discing or tilling operation, the areas shall be dragged with a plank float so as to develop a smooth, even surface. Power equipment may be used for the above operation, but in areas that are too small for power equipment to operate the above operations shall be done with the use of hand tools.

2. The sod shall be placed on the prepared surface with the butting and ends in close contact. The ends of the sod strips shall be staggered.

3. As soon as the sod is laid, it shall be rolled with a 200 pound roller to give it a smooth, even surface to assure good compaction with the sod and the underlying soil and to eliminate air pockets beneath the sod. At the conclusion of the rolling operations, the sodded area shall be watered thoroughly.

4. All sod shall be cut not more than 48 ours before it is to be laid. Any sod that turns brown or dry before it is laid will not be accepted and shall be removed from the job site immediately, at the Contractor's expense.

### 3.02 MAINTENANCE

A. Maintain sodded areas immediately after placement for a six month period or until grass is well established and exhibits a vigorous growing condition.

B. Water when required and in sufficient quantities to prevent grass and underlying soil from drying out.

C. Roll when required to remove minor depressions or irregularities.

D. Control growth of weeds. When using herbicides, apply in accordance with manufacturer's recommendations. Remedy damage resulting from negligent or improper use of herbicides.

## SECTION 02810 – PART III

E. Immediately repair or replace any areas which show deterioration or bare spots.

SECTION 02820 – HYDROSEEDING

PART I – GENERAL

1.01 SCOPE OF WORK

A. Hydroseeding may be preformed in lieu of the specified grass seeding of Section 02800 with the approval of the Engineer.

B. The Contractor shall prepare the soil and apply topsoil on unpaved areas, hydroseed, and maintain the new grass for the specified periods. All as required and specified.

1.02 RELATED WORK SPECIFIED ELSEWHERE

A. Refer to Section 02200, Earthwork and Section 02800, Restoration.

PART II – PRODUCTS

2.01 MATERIALS

A. Hydroseed Mix

Seed shall be fresh, clean, new crop seed composed to the following varieties mixed in the proportions by weight as shown, and tested to the minimum percentage of purity and germination indicated.

<u>Name</u>	<u>By Weight</u>	<u>Proportion</u>	
		<u>Purity</u>	<u>Germination</u>
Perennial Manhattan Ryegrass	65%	98%	90%
Kentucky Blue Grass	25%	85%	90%
Red Fescue	10%	95%	90%

B. Topsoil

Refer to Section 02800

C. Fertilizer

Refer to Section 02800

D. Mulch

Mulching material shall be oat or wheat straw, reasonably free from weeds, and in dry condition. Hay or chopped cornstocks are acceptable.

SECTION 02820 – PART III

PART III – EXECUTION

3.01 INSTALLATION

A. Soil Preparation

Refer to Section 02800

B. Hydroseeding

1. Apply slurry at rate of 60 lb./acre dry weight of seed evenly spread in two operations and at right angles to each other. Slurry to be applied by the use of a hydraulic seeder.

2. Immediately following hydroseeding, mulch areas by means of a mulch blower at a rate of 1,200 pounds per acre on level grades, and 2,000 pounds per acre on slopes.

3. Do not seed area in excess of that which can be mulched on same day.

3.02 MAINTENANCE

A. Maintenance of seeded area shall consist of watering, weeding, cutting and trimming the grass, and performing any other necessary work incidental to the establishment of a good strand of grass reasonably free of weeds or other obnoxious grasses.

B. The maintenance period shall begin immediately upon the completion of the seeding operations and shall continue for a period of not less than forth-five days or until the grass has been cut twice, and if necessary at the direction of the Engineer, until an acceptable strand of grass has been established.

## SECTION 02900 – ABANDONMENT OF PIPES, MANHOLES, AND CHAMBERS

### PART I – GENERAL

#### 1.01 SCOPE OF WORK

A. The Contractor shall furnish all labor, materials, tools, equipment and other incidentals required in the abandonment of pipes, manholes, and chambers at the locations shown on the Drawings and as specified herein.

B. All required permits shall be obtained at the expense of the Contractor and the terms of said permits shall be adhered to as if they were a part of the Specifications. The Contractor's operation shall be in full compliance with governing regulations.

C. Any fees for inspection by State Highway, County Highway, Railroads, and/or Utility Companies personnel shall be paid for by the Contractor.

D. The Contractor's method of construction shall consider all sheeting, shoring and ventilation required by OSHA for safe working environment.

E. All demolition debris shall be hauled away by the Contractor and disposed of in a manner and place in accordance with the New York State Department of Environmental Conservation Rules and Regulations.

#### 1.02 Submittal

A. A written description of the method of construction shall be submitted to the Engineer for approval prior to proceeding. A copy of this information must also be submitted to the governing right-of-way agency having jurisdiction for review and approval.

B. The Contractor shall advise of the source location, and shall submit material certificates of compliance from the supplier with reference standards for each aggregate material specified in this section for approval by the Engineer.

C. The Contractor shall submit copies of loading slips for all select material backfill delivered to the project shall be submitted to the Engineer. Loading slips shall clearly indicate volume, type of material, New York State Department of Transportation Item No., Contractor and date.

## SECTION 02900 – PART II

### PART II – PRODUCTS

#### 2.01 MATERIALS

##### A. For Pipes to be Abandoned

1. Portland Concrete Slurry: Shall meet or exceed the requirements of New York State Department of Transportation, Standard Specifications, Construction and Materials (latest edition), Sections 701-01, 711-10, and 712-01. The slurry mix shall have a consistency and uniformity compatible with the method of placements. The Fly Ash shall be tested for toxicity pursuant to a testing protocol approved by the New York State Department of Environmental Conservation (NYSDEC) and certified to be non-toxic. The Engineer shall be provided with a copy of documentation issued by the NYSDEC.

OR

2. A dry course aggregate meeting the requirements of Section 703 of the New York State Department of Transportation (latest edition). The maximum aggregate size shall not exceed a Type 1A gradation.

##### B. For Manholes to be Abandoned

1. Select granular backfill shall be run of crusher stone meeting the requirements of Specification Section 02200.

##### C. For Bulkheads

1. Portland Cement Mortar (Type 2): Shall meet or exceed the requirements of New York State Department of Transportation Standard Specifications, Construction and Materials, (latest edition) Section 701-01.

2. Common Brick: Shall meet or exceed the requirements of New York State Department of Transportation Standard Specifications, Construction and Materials, (latest edition) Section 704-01.

### PART III – EXECUTION

#### 3.01 PIPELINES

A. The ends of the pipe sections to be abandoned shall be bulkheaded utilizing bricks and mortar, sand bags, mechanical plugs or approved equal. The Contractor shall install a weak Portland Concrete Slurry mixture within the full length of the sewer to be abandoned unless otherwise instructed by the Engineer.

SECTION 02900 – PART III

3.02 MANHOLES AND CHAMBERS

A. Once the pipe sections are completely filled and bulkheaded, the Contractor shall proceed with the abandonment of the manholes/chambers. The Contractor will be required to do the following:

1. Remove the frame and cover(s). The Contractor shall deliver the frame and cover(s) to the Erie County Sewer District Office.
2. Drill four (4) holes, 1 ½” to 2” in diameter, in the base of the manhole/chamber.
3. Remove or demolish the top wall sections of the structure. All structure walls within four feet of existing grade shall be removed. The Contractor will be required to dispose of said material in accordance with State/Federal Regulations.
4. Backfill the manhole/chamber to existing grade utilizing a select granular backfill material or a combination of select granular backfill to a set elevation with native material/topsoil cap as specified on the plan, details and governing permits. The backfill material shall be compacted in lifts.

## SECTION 03100 – CONCRETE FORMWORK

### PART I – GENERAL

#### 1.01 SCOPE OF WORK

A. The Contractor shall furnish all labor, tools, materials, equipment and incidentals required to complete all necessary formwork for this project.

#### 1.02 RELATED WORK

- A. Refer to Section 02200 – Earthwork
- B. Refer to Section 03200 – Concrete Reinforcement
- C. Refer to Section 03300 – Cast-in-Place Concrete
- D. Refer to Section 03310 – Concrete – General

#### 1.03 DESCRIPTION OF WORK

A. The extent of formwork is indicated by the concrete structures shown on the Drawings.

B. The work includes providing formwork and shoring for cast-in-place concrete, and installation into formwork of items furnished by others, such as anchor bolts, setting plates, bearing plates, anchorages, inserts, sleeves, frames, nosing and other items to be embedded in concrete (but including reinforcing steel).

#### 1.04 QUALITY ASSURANCE

A. The installer must examine the substrate and the conditions under which concrete formwork is to be performed, and notify the Contractor in writing of unsatisfactory conditions. Do not proceed with the work until unsatisfactory conditions have been corrected in a manner acceptable to the installer.

#### 1.05 CODES AND STANDARDS

A. Unless otherwise shown or specified, design, construct, erect, maintain, and remove forms and related structures for cast-in-place concrete work in compliance with the American Concrete Institute Standard ACI 347, “Recommended Practice for Concrete Formwork”.

#### 1.06 ALLOWABLE TOLERANCES

A. Construct formwork to provide completed concrete surfaces complying with the tolerances specified in ACI 347, Section 2.4, after removal of forms and prior to patching and finishing of cast-in-place formed surfaces.

## SECTION 03100 – 1.06

B. Check formwork during concrete placement to ensure forms, shores, falsework, ties and other features have not been unduly disturbed by concrete placement methods or equipment. The surveyor shall report in writing to the Engineer any deviations from the allowable tolerances, with a copy of the report to the Contractor.

### 1.07 SUBMITTALS

#### A. Manufacturer's Data – Concrete Formwork

1. For information only, submit two (2) copies of manufacturer's specifications and installation instructions for proprietary materials and items as required, including form coatings, manufactured form systems, ties and accessories.

## PART II – PRODUCTS

### 2.01 FORM MATERIALS

#### A. Form for Exposed Finish Concrete

1. Unless otherwise shown or specified, construct formwork for exposed concrete surfaces with plastic-face plywood, metal, metal-frames, or other panel type materials acceptable to the Engineer, to provide continuous, straight, smooth exposed surfaces. Furnish in largest practicable sizes to minimize number of joints and to conform to joint system shown on Drawings. Provide form material with sufficient thickness to withstand pressure of newly placed concrete without flow or deflection.

2. Plywood forms complying with U.S. Product Standards PS-1, "B-B (Concrete form) Plywood" Class I, Exterior Grade or better, mill-oiled and edge-sealed, with each piece bearing the legible trademark of an approved inspection agency.

#### B. Forms for Unexposed Finish Concrete

Form concrete surfaces which will be unexposed in the finished structure with plastic-face plywood, metal or other acceptable material. Provide lumber that is dressed on at least two edges and one side for tight fit.

### 2.02 DESIGN OF FORMWORK

A. Design, erect, support, brace and maintain formwork so that it will safely support vertical and lateral loads that might be applied, until such loads can be supported by the concrete structure. Carry vertical and lateral loads to ground by formwork system and in-place construction that has attained adequate strength for that purpose. Construct formwork so that concrete members and structures are of correct size, shape, alignment, elevation and position.



## SECTION 03100 – 2.02

B. Design forms and falsework to include assumed values of live load, dead load, weight of moving equipment operated on formwork, concrete mix, height of concrete drop, vibrator frequency, ambient temperature, foundation pressures, stresses, lateral stability, and other factors pertinent to safety of structure during construction.

C. Provide shores and struts with positive means of adjustment capable of taking up formwork settlement during concrete placing operations using wedges or jacks or a combination thereof. Provide trussed supports when adequate foundations for shores and struts cannot be secured.

D. Support form facing materials by structural members spaced sufficiently close to prevent deflection. Fit forms placed in successive units for continuous surfaces to accurate alignment, free from irregularities and within allowable tolerances. Provide camber in formwork as required for anticipated deflections due to weight and pressures of fresh concrete and construction loads for long span members without intermediate supports.

E. Provide temporary openings in wall forms, column forms and at other locations necessary to permit inspection and clean out.

F. Design formwork to be readily removed without impact, shock or damage to cast-in-place concrete surfaces and adjacent materials.

G. Provide formwork sufficiently tight to prevent leakage of cement paste during concrete placement. Solidly butt joints and provide backup material at joints as required to prevent leakage and fins.

H. Side forms of footings may be omitted and concrete placed directly against excavation only when requested by Contractor and accepted by Engineer. When omission of forms is accepted, provide additional concrete required beyond the minimum design profiles and dimensions of the footings as detailed.

## PART III – EXECUTION

### 3.01 FORM CONSTRUCTION

#### A. General

1. Construct forms complying with ACI 347, to the exact sizes, shapes, lines and dimensions shown, and as required to obtain accurate alignment, location, grades, level and plumb work in finished structures. Provide for openings, offsets, sinkages, keyways, recesses, moldings, rustications, reglets, chamfers, blocking, screeds, bulkheads, anchorages and inserts and other features required. Use selected materials to obtain required finishes.

## SECTION 03100 – 3.01

2. Fabricate forms for easy removal without hammering or prying against concrete surfaces. Provide crush plates or wrecking plates where stripping may damage cast concrete surfaces. Provide top forms for inclined surfaces where the slope is too steep to place concrete with bottom forms only. Kerf wood inserts for forming keyways, reglets, recesses and the like, to prevent swelling and assure ease of removal.

3. Provide temporary openings where interior area of formwork is inaccessible for cleanout, for inspection before concrete placement, and for placement of concrete. Brace temporary openings and set tightly to forms to prevent loss of concrete mortar. Locate temporary openings on forms in as inconspicuous a location as possible, consistent with project requirements.

4. Form intersecting planes to provide true, clean-cut corners, with edge grain of plywood not exposed as form for concrete.

5. Provide openings in forms to accommodate other work, including mechanical and electrical work. Accurately place and securely support items required to be built into the forms.

### 3.02 FALSEWORK

A. Erect falsework and support, brace and maintain it to safely support vertical, lateral and asymmetrical loads applied until such loads can be supported by in-place concrete structures. Construct falsework so that adjustments can be made for take-up and settlement.

B. Provide wedges, jacks or camber strips to facilitate vertical adjustments. Carefully inspect falsework and formwork during and after concrete placement operations to determine abnormal deflection or signs of failure; make necessary adjustments to produce work of required dimensions.

### 3.03 FORMS FOR EXPOSED CONCRETE

A. Drill forms to suit ties used and to prevent leakage of concrete mortar around tie holes. Do not splinter forms by driving ties through improperly prepared holes.

B. Do not use metal cover plates for patching holes or defects in forms.

C. Provide sharp, clean corners at intersecting planes, without visible edges or offsets. Back joints with extra studs or girts to maintain true, square intersections.

D. Use extra studs, walers and bracing as required to prevent bowing of forms between studs and to avoid bowed appearance in concrete. Do not use narrow strips of form material which will produce bow.

## SECTION 03100 – 3.03

E. Assemble forms so they may be readily removed without damage to exposed concrete surfaces.

F. Form molding shapes, recesses and projections with smooth-finish materials, and install in forms with sealed joints to prevent displacement.

### 3.04 FORM TIES

A. Provide factory-fabricated, adjustable-length, removable or snap-off metal form ties, designed to prevent form deflection, and to prevent spalling concrete surfaces upon removal. In addition, for walls subjected to a hydrostatic pressure, provide neoprene water stop form ties.

B. Unless otherwise shown, provide ties so that portion remaining within concrete after removal of exterior parts is at least 1 ½” from the outer concrete surface. Unless otherwise shown, provide form ties which will not leave a hole larger than 1” diameter in the concrete surface.

C. Form ties fabricated on the project site and wire ties are not acceptable.

### 3.05 CORNER TREATMENT

A. Form exposed corners of walls, beams and columns to produce square, smooth, solid, unbroken lines, except as otherwise shown. “Exposed” concrete is defined as concrete exposed to view in the finished structure, whether painted or unpainted.

B. Form chamfers with ¾” x ¾” strips, unless otherwise shown, accurately formed and surfaced to produce uniformly straight lines and tight edge joints. Extend terminal edges to required limit and miter chamfer strips at changes in direction.

C. Unexposed corners may be formed either square or chamfered.

### 3.06 CONTROL JOINTS

A. Locate where shown or directed.

### 3.07 PROVISION FOR OTHER TRADES

A. Provide openings in concrete for work to accommodate work of other trades, including those under separate prime contracts (if any). Size and location of openings, recesses and chases are the responsibility of the trade requiring such items. Accurately place and securely support items to be built into forms.

## SECTION 03100 – 3.08

### 3.08 CLEANOUTS, CLEANING AND TIGHTENING

A. Provide temporary openings in forms as required to facilitate cleaning and inspection. Thoroughly clean forms and adjacent surfaces to receive concrete. Remove chips, woods, sawdust, dirt or other debris just before concrete is to be placed. Retighten forms immediately after concrete placement as required to eliminate mortar leaks.

### 3.09 FORM COATINGS

A. Coat form contact surfaces with form-coating compound before reinforcement is placed. Provide commercial formulation form-coating compounds that will not bond with, stain, nor adversely affect concrete surfaces, and will not impair subsequent treatment of concrete surfaces requiring bond or adhesion, nor impede the wetting of surfaces to be cured with water or curing compounds. Do not allow excess form coating material to accumulate in the forms or to come into contact with surfaces against which fresh concrete will be placed. Apply in compliance with manufacturers instructions.

B. Coat steel forms with a non-staining, rust-preventative form oil or otherwise protect against rusting. Rust-stained steel formwork is not acceptable.

### 3.10 INSTALLATION OF EMBEDDED ITEMS

#### A. General

1. Set and build into the work anchorage devices and other embedded items required for other work that is attached to, or supported by, cast-in-place concrete. Use setting drawings, diagrams, instructions and directions provided by suppliers of the items to be attached thereto.

### 3.11 EDGE FORMS AND SCREED STRIPS FOR SLABS

A. Set edge forms or bulkheads and intermediate screed strips for slabs to obtain required elevations and contours in the finished slab surface. Provide and secure units to support types of screeds required.

### 3.12 METAL INSERTS

A. Install metal inserts for anchorage of materials or equipment to concrete construction, not supplied by other trades and as required for the work. Concrete inserts are described in Section 05500 of these Specifications.

## SECTION 03100 – 3.12

B. Provide flashing reglets formed of sheet metal of the same type and gauge as the flashing metal to be built into the reglet, unless otherwise shown. Where resilient or elastomeric sheet flashing or bituminous membranes are terminated in reglets, provide reglets of not less than 20 gauge galvanized sheet steel. Size, shape and install reglets as detailed. Fill reglet or cover face opening to prevent intrusion of concrete or debris.

### 3.13 REMOVAL OF FORMS

#### A. General

Forms shall be removed and concrete temperature maintained in accordance with A.C.I. 301 (latest) Chapter 12.

B. Forms shall not be removed until the concrete has attained the strength to support its own weight and any construction live loads. Under no circumstances shall forms be stripped before concrete is aged 48 hours (walls, columns, and beam faces) and 7 days (slab and beam soffits).

### 3.14 RE-USE OF FORMS

A. Clean and repair surfaces of forms to be re-used in the work. Split, frayed, delaminated or otherwise damaged form facing material will not be acceptable. Apply new forms coating compound material to concrete contact surfaces as specified for new formwork.

B. When forms are extended for successive concrete placement, thoroughly clean surfaces, remove fins and laitance, and tighten forms to close all joints. Align and secure joints to avoid offsets. Do not use "patched" forms for exposed concrete surfaces except as acceptable to the Engineer.

## SECTION 03200 – CONCRETE REINFORCEMENT

### PART I – GENERAL

#### 1.01 SCOPE OF WORK

A. The Contractor shall furnish all labor, tools, materials, equipment and incidentals required to provide the required reinforcement as shown on the Plans and specified herein.

#### 1.02 RELATED WORK

- A. Refer to Section 03100 – Concrete Formwork
- B. Refer to Section 03300 – Cast-in-Place Concrete
- C. Refer to Section 03310 – Concrete – General

#### 1.03 DESCRIPTION OF WORK

A. The extent of concrete reinforcement is shown on the Drawings and in schedules.

B. The work includes fabrication and placement of reinforcement for cast-in-place concrete, including bars, welded wire fabric, ties and supports.

#### 1.04 QUALITY ASSURANCE

A. The installer must examine the substrate and the conditions under which concrete reinforcement is to be performed, and notify the Contractor in writing of unsatisfactory conditions. Do not proceed with the work until unsatisfactory conditions have been corrected in a manner acceptable to the installer.

#### B. Codes and Standards

1. Comply with requirements of the following codes and standards, except as herein modified:

- a. American Concrete Institute, ACI 315-“Manual of Standard Practice for Detailing Reinforced Concrete Structures”.
- b. American Concrete Institute, ACI 318-“Building Code Requirements for Reinforced Concrete”.
- c. Concrete Reinforcing Steel Institute – “Manual of Standard Practice”.

## SECTION 03200 – 1.05

### 1.05 SUBMITTALS

#### A. Manufacturer’s Data – Concrete Reinforcement

1. For information only, submit two (2) copies of manufacturer’s specifications and installation instructions for all proprietary materials and reinforcement accessories. Submit two (2) certified copies of mill reports covering the chemical and physical properties of each type of steel used.

#### B. Shop Drawings – Concrete Reinforcement

1. The Contractor shall make complete sets of shop drawings as specified in the General Contract Conditions. Comply with ACI 315 “Manual of Standard Practice for Detailing Reinforced Concrete Structures” (for concrete beam rebar cover refer to drawings), show bar schedules, stirrup spacing, diagrams of bent bars, arrangements and assemblies, as required for the fabrication and placement of concrete reinforcement. Include special reinforcement required at openings through concrete structures.

2. Complete detailed shop drawings and schedules shall be submitted by the Contractor for review by the Engineer as specified in GCC-18.

### 1.06 PRODUCT DELIVERY, HANDLING AND STORAGE

A. Deliver reinforcement to the project site bundled, tagged and marked. Use metal tags indicating bar size, lengths, and other information corresponding to markings shown on placement diagrams.

B. Store concrete reinforcement materials at the site to prevent damage and accumulation of dirt or excessive rust.

## PART II – PRODUCTS

### 2.01 MATERIALS

#### A. Reinforcing Bars: ASTM A615, and as follows:

1. Provide Grade 60 for Bar Nos. 3 to 18, except as otherwise indicated.

#### B. Steel Wire: ASTM A82

#### C. Welded Wire Fabric: ASTM A185

SECTION 03200 – 2.01

D. Supports for Reinforcement

1. Bolsters, chairs, spacers and other devices for spacing, supporting and fastening reinforcement in place, use wire bar type supports complying with PS7-66, unless otherwise indicated. Do not use wood, brick and other unacceptable materials.

2. For slabs on grade, use supports with sand plates or horizontal runners where wetted base materials will not support chair legs.

3. For exposed-to-view concrete surfaces, where legs of supports are in contact with forms, provide Class “D” stainless steel protected bar supports.

2.02 FABRICATION

A. General

1. Shop fabricate reinforcing bars to conform to required shapes and dimensions, with fabrication tolerances complying with ACEI 315. In case of fabricating errors, do not re-bend or straighten reinforcement in a manner that will injure or weaken the material. Field bending is not acceptable.

B. Unacceptable Materials

1. Reinforcement with any of the following defects will not be permitted in the work:
  - a. Bar lengths, depths, and bends exceeding specified fabrication tolerances.
  - b. Bends or kinks not indicated on Drawings or final shop drawings.
  - c. Bars with reduced cross-section due to excessive rusting or other cause.

PART III – EXECUTION

3.01 INSTALLATION

A. Comply with the specified codes and standards, and Concrete Reinforcing Steel Institute recommended practice for “Placing Reinforcing Bars”, for details and methods of reinforcement placement and supports, and as herein specified.



## SECTION 03200 – 3.01

B. Clean reinforcement to remove loose rust and mill scale, earth, ice and other materials which reduce or destroy bond with concrete.

C. Position, support and secure reinforcement against displacement by formwork, construction, or concrete placement operations. Locate and support reinforcing by metal chairs, runners, bolsters, spacers and hangers, as required. Steel reinforcing may not be heat bent.

D. Place reinforcement to obtain minimum coverages for concrete protection. Arrange space and securely tie bards and bar supports together with 16 gauge wire to hold reinforcement accurately in position during concrete placement operations. Set wire ties so that ends are directed away from exposed concrete surfaces.

E. Install welded wire fabric in as long lengths as practicable. Lap adjoining pieces at least one full mesh and lace splices with 16 gauge wire. Do not make end laps midway between supporting beams, or directly over beams of continuous structures. Offset end laps in adjacent widths to prevent continuous laps. All welded wire fabric shall be supported.

F. Provide sufficient numbers of supports and of strength to carry reinforcement. Do not place reinforcing bars more than 2” beyond the last leg of any continuous bar support. Do not use supports as bases for runways for concrete conveying equipment and similar construction loads.

### 3.02 SPLICES

Provide standard reinforcement splices unless indicated otherwise on the Drawings by lapping ends, placing bars in contact, and tightly wire tying. Comply with requirements of ACI 318 for minimum lap of spliced bars. No welded splices and/or ties will be accepted.

## SECTION 03300 – CAST-IN-PLACE CONCRETE

### PART I – GENERAL

#### 1.01 SCOPE OF WORK

- A. The extent of cast-in-place concrete work is shown on the Drawings.
- B. The work includes providing cast-in-place concrete consisting of Portland cement, fine and coarse aggregate, water, and selected admixtures; combined, mixed, transported, placed, finished and cured as herein specified.

#### 1.02 RELATED WORK

- A. Concrete Form Work – Section 03100
- B. Concrete Reinforcement – Section 03200
- C. Concrete, General – Section 03310

#### 1.03 QUALITY ASSURANCE

- A. Codes and Standards
  - 1. Comply with the provisions of the following codes and standards, except as otherwise shown or specified:
    - a. ACI 301 – “Specifications for Structural Concrete for Buildings”
    - b. ACI 304 – “Recommended Practice for Measuring, Mixing, Transporting and Placing Concrete”
    - c. ACI 305 – “Recommended Practice for Hot Weather Concreting”
    - d. ACI 306 – “Recommended Practice for Cold Weather Concreting”
    - e. ASTM C-94 – “Ready-Mixed Concrete”
  - 2. The continuity of color and texture for exposed concrete surfaces is of prime importance. Maintain such controls and procedures, in addition to those specified, as necessary to provide continuous match of concrete work.

#### 1.04 SUBMITTALS

- A. Coordinate the work of this section with requirements for submittals specified in Section 03310.
- B. Delivery Tickets: Furnish copies of delivery tickets for each load of concrete delivered to site. Provide items of information as specified.

SECTION 03300 – PART 2.01

PART II – PRODUCTS

2.01 MATERIALS

A. Concrete

1. For concrete materials, see Section 03310.

B. Joint Materials

1. Waterstops

- a. Flat dumbbell type waterstops at construction joints and other joints where no movement is expected, unless otherwise shown; web thickness not less than 3/8" for widths 9" and over.
- b. At expansion joints provide 9" x 3/8" dumbbell type with 3/4" diameter minimum center bulb.
- c. Provide either rubber or PVC waterstops at Contractor's option, with rubber units complying with Corps of Engineers CRD-C513 and PVC units complying with CRD-C572.
- d. Manufacturers offering products to comply with requirements include the following: Electrovert, Inc.; W. R. Meadows, Inc.; Weather guard Prod. Corp.; Gates Rubber Co.; and Serviced Products/W.R. Grace, or equal.

2. Expansion Joints

- a. Preformed cork expansion joint filler material where required shall conform with ASTM Spec. D1752, Type 2, or Fed. Spec. HH-F-341, Type 2, Class B.
- b. Products offered by manufacturers to comply with the requirements include the following: Sonoflex Cork by Sonneborn-Contech, Inc.; Tex-Cork by J&P Petroleum Products, Inc., or equal.
- c. A resilient, closed-cell, cross-linked ethylene vinyl acetate material may also be used.
- d. Products offered by manufacturers to comply with the requirements include the following: Evazote 50 by E-poxy Industries, Inc., similar by Tremco, W.R. Grace & Co., or equal.

SECTION 03300 – PART 2.01

C. Bonding Materials

1. Epoxy-Resin Bonding Agent

a. 2-component, mineral-filled, epoxy-polysulphide polymer complying with FS MMM-G-650, Type I or Type II, Grade A.

b. Products offered by manufacturers to comply with the requirements for epoxy-resin type grout include the following: Sikadur Hi-Mod – Sika Chemical Corp.; Epoxitite Grout – W.R. Grace; Polytops – Chem-Masters Corp.; Sonobond – Sonneborn-Contech.; Probond ET-50 – Protec Industries, or equal.

D. Curing

1. Concrete shall be protected against loss of moisture, rapid drying or temperature changes, mechanical injury, or injury from rain or flowing water. Forms shall be removed and concrete temperature maintained in accordance with ACI 301 (latest) Chapter 12.

2. Curing shall commence as soon as free water has disappeared from the surfaces after finishing. Curing of formed soffits of beams, girders, floor slabs, and similar surfaces shall be accomplished by moist curing with forms in place for full curing period.

3. Except where specific methods of curing are specified, curing may be accomplished by any one of the following methods:

a. Moist Curing: Surfaces shall be kept continuously wet by covering with burlap, mats or sand, thoroughly saturated with water and covering kept wet by spraying or hosing. Place materials to provide complete surface coverage and lap all joints minimum 3 inches.

b. Impervious-Sheeting Curing: Surfaces shall be thoroughly wetted with a fine spray of water and then covered with waterproof paper, polyethylene sheeting or polyethylene-coated waterproof paper. Edges and ends of sheeting shall be overlapped not less than 4 inches and securely cemented or taped to form a continuous cover. Sheeting shall be weighted down to prevent displacement and shall be repaired or replaced if torn, damaged or removed during curing period.

4. Moisture-retaining cover: One of the following:

- a. Waterproof paper, complying with ASTM C 171, Type 1 or Type 2
- b. Polyethylene Sheeting, complying with AASHTO M171
- c. Polyethylene-coated burlap

SECTION 03300 – PART 2.02

2.02 CONCRETE MIXING

A. General

1. Concrete shall be transit-mixed as specified herein. Batch plants must comply with the requirements of ACI 304, with sufficient capacity to produce concrete of the qualities specified in quantities required to meet the construction schedule. All plant facilities are subject to testing laboratory inspection and acceptance of the Engineer.

B. Ready-Mix Concrete

1. Comply with the requirements of ASTM C-94, and as herein specified, provided the quantity and rate of delivery will permit unrestricted progress of the work in accordance with the placement schedule. During hot weather, or under conditions contributing to rapid setting of concrete, a shorter mixing time than specified in ASTM C-94 may be required, as specified below. Proposed changes in mixing procedures, other than herein specified, must be accepted by the Engineer before implementation.

C. Modifications to ASTM C-94 are as follows:

1. Quality of Concrete

a. Provide concrete materials, proportions and properties as herein specified, in lieu of ASTM Section 4.

2. Tolerances in Slump

a. Provide concrete at slump herein specified. Such limit shall be considered nominal slumps and limited as dictated in Section 6, paragraph 6.1.1.

3. Certification

a. All deliveries shall be accompanied by a ticket or tapes printed in accordance with New York State Department of Transportation requirements verifying quantities.

4. Maintain Equipment

a. Equipment should be maintained in proper operating condition, with drums cleaned before charging each batch. Schedule rates of delivery in order to prevent delay of placing the concrete after mixing, or holding dry-mixed materials too long in the mixer before the addition of water and admixtures.

SECTION 03300 – 3.01

PART III – EXECUTION

3.01 CONCRETE PLACEMENT

A. General

1. Place concrete in compliance with the practices and recommendation of ACI-304, and as herein specified.
2. Deposit concrete continuously or in layers of such thickness that no concrete will be placed on concrete which has hardened sufficiently to cause the formation of seams or planes of weakness within the section. If a section cannot be placed continuously, provided construction joints as herein specified. Perform concrete placing at such a rate that concrete which is being integrated with fresh concrete is still plastic. Deposit concrete as nearly as practicable to its final location to avoid segregation due to rehandling or flowing. Do not subject concrete to any procedure which will cause segregation.
3. Screen concrete which is to receive other construction to the proper level to avoid excessive skimming or grouting.
4. Do not use concrete which becomes non-plastic and unworkable, or does not meet the required quality control limits, or which has been contaminated by foreign materials. Do not use retempered concrete. Remove rejected concrete from the project site and dispose of in an acceptable location.

B. Pre-Placement Inspection

1. Before placing concrete, inspect and complete the formwork installation, reinforcing steel, and items to be embedded or cast-in. Notify other crafts involved in ample time to permit the installation of their work; cooperate with other trades in setting such work, as required. Thoroughly wet wood forms immediately before placing concrete, as required where form coatings are not used.
2. Soil at bottom of foundation systems is subject to testing for soil bearing value by a testing laboratory, as directed by the Engineer, at the Contractor's expense. Place concrete immediately after approval of foundation excavations. Dewater all areas as required before placing concrete.

C. Concrete Conveying

1. Handle concrete from the point of delivery and transfer to the concrete conveying equipment and to the locations of final deposit as rapidly as practicable by methods which will prevent segregation and loss of concrete mix materials.

SECTION 03300 – 3.01

2. Provide mechanical equipment for conveying concrete to ensure a continuous flow of concrete at the delivery end. Provide runways for wheeled concrete conveying equipment from the concrete delivery point to the locations of final deposit. Keep interior surfaces of conveying equipment, including chutes, free of hardened concrete, debris, water, snow, ice and other deleterious materials. No changes in mix design or slump will be permitted for pumping without approval by the Engineer.

D. Placing Concrete into Forms

1. Deposit concrete in forms in horizontal layers not deeper than 18” and in a manner to avoid inclined construction joints.

2. Remove temporary spreaders in forms when concrete placing has reached the elevation of such spreaders.

3. Consolidate concrete placed in forms by mechanical vibrating equipment supplemented by hand-spading, rodding or tamping. Use vibrators designed to operate with vibratory element submerged in concrete, maintaining a speed of not less than 6000 impulses per minute when submerged in the concrete. Vibration of forms and reinforcing will not be permitted, unless otherwise accepted by the Engineer.

E. Do Not Use Vibrators To Transport Concrete Inside Of Forms

1. Insert and withdraw vibrators vertically at uniformly spaced locations not farther than the visible effectiveness of the machine. Do not insert vibrators into lower layers of concrete that have begun to set. At each insertion, limit the duration of the vibration to the time necessary to consolidate the concrete and complete embedment of reinforcement and other embedded items without causing segregation of the mix.

2. Do not place concrete in supporting elements until the concrete previously placed in columns and walls is no longer plastic.

F. Placing Concrete Slabs

1. Deposit and consolidate concrete slabs in a continuous operation, within the limits of construction joints, until the placing of a panel or section is completed.

G. Consolidate concrete during placing operations using mechanical vibrating equipment, so that concrete is thoroughly worked around reinforcement and other embedded items and into corners.

1. Consolidate concrete placed in beams and girders or supported slabs, and against bulkheads of slabs on ground, as specified for formed concrete structures. Consolidate concrete in the remainder of slabs by vibrating bridge screed, roller pipe screed, or

## SECTION 03300 – 3.01

other acceptable methods. Limit the time of vibrating consolidation to prevent bringing an excess of fine aggregate to the surface.

2. Bring slab surfaces to the correct level with a straight edge and strike off. Use bull floats or derbies to smooth the surface, leaving it free of humps or hollows. Do not sprinkle water on the plastic surface. Do not disturb the slab surfaces prior to beginning finishing operations.

H. Maintain reinforcing steel in the proper position continuously during concrete placement operations

### 3.02 BONDING

A. Roughen surfaces of set concrete at all joints, except where bonding is obtained by use of a concrete bonding agent, and clean surfaces of laitance, coatings, loose particles, and foreign matter. Roughen surfaces in a manner to expose bonded aggregate uniformly and to not leave laitance, loose particles of aggregate, or damaged concrete at the surface.

B. Prepare for bonding of fresh concrete to new concrete that has set but is not fully cured, as follows:

1. At joints between footings and walls or columns, and between walls or columns and beams or slabs they support, and elsewhere unless otherwise specified herein, dampen, but do not saturate, the roughened and cleaned surface of set concrete immediately before placing fresh concrete.

2. At joints in exposed work: at vertical joints in walls; at joints in girders, beams, supported slabs and other structural members; and at joints designed to contain liquids; dampen, but do not saturate, the roughened and cleaned surface of set concrete and apply a liberal coating of neat cement grout.

3. Use neat cement grout consisting of equal parts Portland cement and fine aggregate by weight and not more than 6 gallons of water per sack of cement. Apply with a stiff broom or brush to a minimum thickness of 1/16". Deposit fresh concrete before cement grout has attained its initial set.

4. In lieu of neat cement grout, bonding grout may be a commercial bonding agent. Apply to cleaned concrete surfaces in accordance with the printed instruction of the bonding material manufacturer.

C. Prepare for bonding of fresh concrete to fully-cured hardened concrete or existing concrete by using an epoxy-resin adhesive binder, as follows:



## SECTION 03300 – 3.02

1. Handle and store epoxy-resin adhesive binder in compliance with the manufacturer's printed instructions, including safety precautions.
2. Mix the epoxy-resin adhesive binder in the proportions recommended by the manufacturer, carefully following directions for safety of personnel.
3. Before depositing fresh concrete, thoroughly roughen and clean hardened concrete surfaces and coat with epoxy-resin grout not less than 1/16" thick. Place fresh concrete while the epoxy-resin material is still tacky, without removing the in-place grout coat, and as directed by the epoxy-resin manufacturer.

### 3.03 COLD WEATHER PLACING

- A. Protect all concrete work from physical damage or reduced strength which could be caused by frost, freezing actions, or low temperatures, in compliance with the requirements of ACI 306 and ACI 301 and as herein specified.
- B. In addition, when air temperature has fallen to or is expected to fall below 40 degrees F., uniformly heat all water and aggregates before mixing as required to obtain a concrete mixture temperature of not less than 50 degrees F. and not more than 80 degrees F. at point of placement.
- C. Do not use frozen materials or materials containing ice or snow. Do not place concrete on frozen subgrade or on subgrade containing frozen materials. Ascertain that forms, reinforcing steel, and adjacent concrete surfaces are entirely free of frost, snow and ice before placing concrete.
- D. Do not use calcium chloride, salt, and other materials containing antifreeze agents or chemical accelerators, unless otherwise accepted in writing by the Engineer.

### 3.04 HOT WEATHER PLACING

- A. When hot weather conditions exist that would seriously impair the quality and strength of concrete, place concrete in compliance with ACI 305 and ACI 301 and as herein specified.
- B. Cool ingredients before mixing to maintain concrete temperature at time of placement below 85 degrees F. Mixing water may be chilled, or chopped ice may be used to control the concrete temperature provided the water equivalent of the ice is calculated to the total amount of mixing water.
- C. Cover reinforcing steel with water-soaked burlap if it becomes too hot, so that the steel temperature will not exceed the ambient air temperature immediately before embedment in concrete.

## SECTION 03300 – PART 3.04

D. Wet forms thoroughly before placing concrete.

E. Do not use retarding admixtures. Retarding admixtures may be used with approval provided they are by the same manufacturer as the water reducer specified herein, and will have the same effect on water reduction, air entrainment and workability.

### 3.05 UNDERWATER PLACING

A. Concrete placement in water will only be permitted if conditions render it impossible or inadvisable to dewater excavations before placing concrete, and only when acceptable to the Engineer.

B. Revise the concrete mix design to suit underwater placement requirements, and submit to the Engineer for acceptance before commencing underwater placement operations. Deposit concrete by the tremie method, or other suitable means, in continuous placement to prevent formation of layers.

### 3.06 JOINTS

#### A. Construction Joints

1. Locate and install construction joints, which are not shown on the Drawings, so as not to impair strength and appearance of the structure, as acceptable to the Engineer. Locate construction joints on shop drawings, if required but not shown, as follows:

a. In walls, at not more than 30 feet on center in any horizontal direction; at top of footings; at top of slabs on ground; at top and bottom of door and window openings or as required to conform to architectural details as directed by the Engineer; and at the underside of the deepest beam or girder framing into wall.

b. In columns or piers, at the top of footing; at the top of slabs on ground; and at the underside of the deepest beam or girder framing into the column or pier.

c. In slabs, so as to divide the slab into areas not in excess of 625 square feet maximum, or 25 feet, unless otherwise accepted by the Engineer. Conform to slab placement diagrams or pattern layout for placement where shown.

2. Provide keyways at least 1 ½" deep in all construction joints in wall, slabs, and between walls and footings; accepted bulkheads designed for this purpose may be used for slabs.

a. Place construction joints perpendicular to the main reinforcement. Continue all reinforcement across construction joints.

## SECTION 03300 – 3.06

### B. EXPANSION JOINTS

1. Expansion joints shall be located a minimum of 90 feet on center or as shown on the Plans, and/or as directed by the Engineer.
2. All expansion joints shall be provided with flexible waterstops.
3. Reinforcement or other imbedded metal items bonded to the concrete (except dowels in floors bonded on only one side of joints) shall not extend continuously through any expansion joint.

### C. Waterstops

1. Provide waterstops in construction joints as shown on the Drawings. Install waterstops to form a continuous diaphragm in each joint. Make provisions to support and protect waterstops during the progress of the work. Fabricate field joints in waterstops in accordance with manufacturers printed instructions. Protect waterstop material from damage where it protrudes from any joint.
2. The Drawings may not indicate waterstops in expansion joints; however, all expansion joint shall be provided with waterstops.

### D. Isolation Joints in Slabs on Ground

1. Provide isolation joints in slabs on ground at all points of contact between slabs on ground and vertical surfaces, such as column pedestals, foundation walls, grade beams and elsewhere as indicated.

## 3.07 FINISH OR FORMED SURFACES

### A. Standard Rough Form Finish

1. Provide standard rough form finish to all concrete formed surfaces that are to be concealed in the finish work or by other construction, unless otherwise shown or specified.
2. Standard rough form finish shall be the concrete surface having the texture imparted by the form facing material used, with defective areas repaired and patched as specified, and all fins and other projections exceeding ¼” in height rubbed down with wood blocks.

### B. Standard Smooth Finish

1. Provide standard smooth finish for all concrete formed surfaces that are to be exposed to view, or that area to be covered with a coating material applied directly

## SECTION 03300 – 3.07

to the concrete or a covering material bonded to the concrete such as waterproofing, dampproofing, painting, or other similar system.

2. Standard smooth finish shall be the as-cast concrete surface as obtained with eh form facing material, with defective areas repaired and patched as specified, and all fins and other projections on the surface completely removed and smoothed.

### C. Grout Finish

1. Provide grout finish to all interior and exterior concrete vertical surfaces which are exposed to view in the finish structure, consisting of one part Portland cement to 1 ½ parts of fine aggregate passing a No. 30 mesh by volume, mixed with only enough water to produce a consistency of thick paint.

2. Blend the Portland cement portion of standard Portland cement and white Portland cement, proportioned as determined by trial mixes, so that the final color of grout, when dry, will be approximately the same color as the adjacent concrete.

3. Thoroughly wet the concrete surface and apply grout immediately to the wetted surfaces. Spread grout with clean burlap pads or sponge rubber floats to fill all pits, air bubbles and surface holes. Remove excess grout by scraping, followed by rubbing with clean burlap to remove any visible grout film. Keep grout damp during the setting period by means of fog spray in hot, dry weather. Complete any area in the same day it is started, with the limits of any area being the natural breaks in the finished surface.

### D. Related Unformed Surfaces

1. At tops of walls, horizontal offsets, and similar unformed surfaces occurring adjacent to formed surfaces, strike off smooth and finish with a texture matching the adjacent formed surfaces. Continue the final surface treatment of formed surfaces uniformly across the adjacent unformed surfaces, unless otherwise shown.

### E. Exterior Platforms and Steps

Concrete surfaces shall be finished with a float and troweled by skilled workmen. After the surfaces have been leveled and finished and before the concrete takes its final set, the surfaces shall be evenly stroked with a broom to give a slightly rough and uniform finish. Steps, unless otherwise shown on the Plans, shall be fitted with non-slip tread nosings. Nosings are described in section 05500 of these Specifications.

SECTION 03300 – 3.08

3.08 MONOLITHIC SLAB FINSHES

A. Scratch Finish

1. Apply scratch finish to monolithic slab surfaces that are to receive concrete floor topping or mortar setting beds for tile, Portland cement terrazzo, and other bonded applied cementitious finish flooring material, and as shown on the Drawings.

2. After placing slabs, plane the surface to a tolerance not exceeding ¼" to 2' when tested with a 2' straightedge. Slope surfaces uniformly to drains where required. After leveling, roughen the surface before the final set with stiff brushes, brooms or rakes.

B. Float Finish

1. Apply float finish to monolithic slab surfaces that are to receive trowel finish and other finishes as hereinafter specified, and slab surfaces which are to be covered with membrane or elastic waterproofing, membrane or elastic roofing, or sand bed terrazzo, and as shown on the Drawings or in schedules.

2. After placing concrete slabs, do not work the surface further until ready for floating. Begin floating when the surface water has disappeared or when the concrete has stiffened sufficiently to permit the operation of a power-driven float, or both. Consolidate the surface with power-driven floats, or by hand-floating if area is small or inaccessible to power units. Check and level the surface plane to a tolerance not exceeding ¼" in 10' when tested with a 10' straightedge placed on the surface at not less than two different angles. Cut down high spots and fill all low spots. Uniformly slope surfaces to drains. Immediately after leveling, refloat the surface to a uniform, smooth, granular texture.

C. Trowel Finish

1. Apply trowel finish to monolithic slab surfaces that are to be exposed to view, unless otherwise shown, and slab surfaces that are to be covered with resilient flooring, paint, or other thin-film finish coating system.

2. After floating, begin the first trowel finish operation using a power-driven trowel. Begin final troweling when the surface produces a ringing sound as the trowel is moved over the surface.

3. Consolidate the concrete surface by the final hand troweling operation, free of trowel marks, uniform in texture and appearance, and with a surface plane tolerance not exceeding 1/8" in 10' when tested with a 10' straightedge. Grind smooth surface defects which would telegraph through applied floor covering system.

## SECTION 03300 – 3.09

### 3.09 CONCRETE CURING AND PROTECTION

#### A. General

1. Protect freshly placed concrete from premature drying and excessive cold or hot temperature, and maintain without drying at a relatively constant temperature for a period of time necessary for hydration of the cement and proper hardening of the concrete.
2. Start initial curing as soon as free water has disappeared from the concrete surface after placing and finishing. Weather permitting, keep continuously moist for not less than 72 hours.
3. Begin final curing procedures immediately following initial curing and before the concrete has dried. Continue final curing for at least 168 cumulative hours (not necessarily consecutive) during which the concrete has been exposed to air temperatures above 50 degrees F. Avoid rapid drying at the end of the final curing period.

#### B. Curing Method

1. Perform curing of concrete by moist curing or moisture-retaining cover curing, as herein specified.
2. For curing, use only water that is free to impurities which could etch or discolor exposed, natural concrete surfaces.
3. Provide moisture curing by any of the following methods:
  - a. Keeping the surface of the concrete continuously wet by covering with water.
  - b. Continuous water-fog spray.
  - c. Covering the concrete surface with the specified absorptive cover continuously wet. Place absorptive cover so as to provide coverage of the concrete surfaces and edges with a 4" lap over adjacent absorptive covers.

#### C. Moisture-Cover Curing

1. Cover the concrete surfaces with the specified moisture-retaining cover for curing concrete, placed in the widest practicable width with sides and ends lapped at least 3" and sealed by waterproof tape or adhesive. Immediately repair any holes or tears during the curing period using cover material and waterproof tape.

## SECTION 03300 – 3.09

### D. Curing Formed Surfaces

1. Cure formed concrete surfaces, including the under-sides of girders, beams, supported slabs and other similar surfaces by moist curing with the forms in place for the full curing period or until forms are removed. If forms are removed, continue curing by methods specified above, as applicable.

### E. Curing Unformed Surfaces

1. Initially cure unformed surfaces, such as slabs, floor topping and other flat surfaces by moist curing, whenever possible.

2. Final cure unformed surfaces, unless otherwise specified, by any of the methods specified above, as applicable.

3. Final cure concrete surfaces to receive liquid floor hardener or finish flooring by use of moisture-retaining cover, unless otherwise acceptable to the Engineer.

### F. Temperature of Concrete During Curing

1. When the atmospheric temperature is 90 degrees F. and below, maintain the concrete temperature at not less than 55 degrees F. continuously throughout the curing period. When necessary, make arrangements before concrete placing for heating, covering, insulation or housing as required to maintain the specified temperature and moisture conditions continuously for the concrete curing period. Provide cold weather protections complying with the requirements of ACI 306 and ACI 301.

2. When the atmospheric temperature is 80 degrees F. and above, or during other climatic conditions which will cause too rapid drying of the concrete, make arrangements before the start of concrete placing for the installation of wind breaks or shading, and for fog spraying, wet sprinkling, or moisture-retaining covering. Protect the concrete continuously for the concrete curing period. Provide hot weather protections complying with the requirements of ACI 305 and ACI 301.

G. Maintain concrete temperature as uniformly as possible, and protect from rapid atmospheric temperature changes. Avoid temperature changes in concrete which exceed 5 degrees F in any one hour and 50 degrees F in any 24-hour period.

### H. Protection from Mechanical Injury

1. During the curing period, protect concrete from damaging mechanical disturbances including load stresses, heavy shock, excessive vibration, and from

## SECTION 03300 – 3.09

damage caused by rain or flowing water. Protect all finished concrete surfaces from damage by subsequent construction operations.

### 3.10 MISCELLANEOUS CONCRETE ITEMS

#### A. Filling-In

1. Fill in holes and openings left in concrete structures for the passage or work by other trades, unless otherwise shown or directed, after the work of other trades is in place. Mix, place and cure concrete as herein specified, to blend with in-place construction. Provide all other miscellaneous concrete filling shown or required to complete the work.

#### B. Curbs

1. Provide monolithic finish to interior curbs by tripping forms while concrete is still green and steel-troweling surfaces to a hard, dense finish with corners, intersections and terminations slightly rounded.

#### C. Equipment Bases and Foundations

1. Provide machine and equipment bases and foundations. Set anchor bolts for machines and equipment to template at correct elevations, complying with certified diagrams or templates of the manufacturer furnishing the machines and equipment.

#### D. Repair of Formed Surfaces

1. Repair exposed to view formed concrete surfaces, where possible, that contain defects which adversely affect the appearance of the finish. Remove and replace the concrete having defective surfaces if the defects cannot be repaired to the satisfaction of the Engineer. Surface defects, as such, include color and texture irregularities, cracks, spalls, air bubbles, honeycomb, rock pockets, and holes left by the rods and bolts; fins and other projections on the surface; and stains and other discoloration that cannot be removed by cleaning.

2. Repair concealed formed concrete surfaces, where possible, that contain defects that adversely affect the durability of the concrete. If defects cannot be repaired, remove and replace the concrete having defective surfaces. Surface defects, as such, include cracks in excess of 0.01" wide, cracks of any width and other surface deficiencies which penetrate to the reinforcement or completely through non-reinforced sections, honeycomb, rock pockets, holes left by tie rods and bolts, and spalls except minor breakage at the corner.

3. Structures designed and intended to hold water or liquids shall be made watertight by the Contractor to conform with the following requirements. When the structures are filled with sewage or other liquids, any cracks or leaks shall be repaired. If the



## SECTION 03300 – 3.10

structure does not stop leaking to the satisfaction of the Engineer, the Contractor shall repair or replace, at this own expense, such parts of the work as may be necessary to secure the desired results.

### E. Repair of Unformed Surfaces

1. Test unformed surfaces, such as monolithic slabs, for smoothness and to verify surface plane to the tolerances specified for each surface and finish. Correct low and high areas as herein specified.

2. Test unformed surfaces sloped to drain for trueness of slope, in addition to smoothness, using a template having the required slope. Correct high and low areas as herein specified.

3. Repair finished unformed surfaces that contain defects which adversely affect the durability of the concrete. Surface defects, as such, include crazing, cracks in excess of 0.01" wide or which penetrate to the reinforcement or completely through non-reinforced sections regardless of width, spalling, popouts, honeycomb, rock pockets and other objectionable conditions.

4. Structures designed and intended to hold water or liquids shall be made watertight by the Contractor to conform with the following requirements. When the structures are filled with sewage or other liquids, any cracks or leaks shall be repaired. If the structure does not stop leaking to the satisfaction of the Engineer, the Contractor shall repair or

replace, at his own expense, such part of the work as may be necessary to secure the desired results.

F. Correct high areas in unformed surfaces by grinding, after the concrete has cured at least 14 days.

G. Concrete low areas in unformed surfaces during, or immediately after completion of surface finishing operations by cutting out the low areas and replacing with fresh concrete. Finish repaired areas to blend into adjacent concrete. Proprietary patching compounds may be used when acceptable to the Engineer.

H. Repair defective areas, except random cracks and single holes not exceeding 1" diameter, by cutting out and replacing with fresh concrete. Remove defective areas to sound concrete with clean, square cuts, and expose reinforcing steel with at least 3/4" clearance all around. Dampen all concrete surfaces in contact with patching concrete, and brush with a neat cement grout coating or concrete bonding agent. Place patching concrete before grout takes its initial set. Mix patching concrete of the same materials to provide concrete of the same type or class as the original adjacent concrete. Place, compact and finish as required to blend with adjacent finished concrete. Cure in the same manner as adjacent concrete.

SECTION 03300 – 3.10

I. Repair isolated random cracks and single holes not over 1” in diameter by the dry-pack method. Groove the top of cracks, and cut out holes to sound concrete and clean of dust, dirt and loose particles. Dampen all cleaned concrete surfaces and brush with a neat cement grout coating. Place dry-pack before the cement grout takes its initial set. Mix dry-pack, consisting of one part Portland cement to 2 ½ parts fine aggregate passing a No. 16 mesh sieve, using only enough water as required for handling and placing. Compact dry-pack mixture in place and finish to match adjacent concrete. Keep patched areas continuously moist for not less than 72 hours.

Repair methods not specified above may be used, subject to the acceptance of the Engineer.

3.11 CONCRETE FILL-TANK, WET WELL, SUMP, CHANNEL - BOTTOMS

A. The surface of the structural slabs shall be struck off true to grades shown on the Drawings.

B. During placement of the slab, as soon as the condition of the concrete permits, before it has hardened appreciably (and normally within four hours after depositing) all water, inadvertent film, laitance, and loose aggregate shall be removed from the surface by means of wire or bristle brooms in such a manner as to leave the coarse aggregate slightly exposed and the surface clean and generally in condition to provide a good bond for the finish. The brooms shall “roll” the film and laitance (if any) from the slab and leave it clean. Avoid “muddying” the surface by brooming too soon. Raking shall not be employed, and large

depressions and general unevenness shall be avoided. The surface thus prepared shall be covered with a layer of sisal-kraft paper or approved equal, to prevent its filling with debris from other construction operations before the floor finish is applied.

C. If, in the opinion of the Engineer, the surface preparation is not properly done and the resulting surfaces are unsatisfactory, the Contractor shall, at his own expense, chip the surfaces by hand or power tools to expose clean virgin concrete (mortar or aggregate) over every square inch of surface to receive mortar finish.

D. Concrete mortar finish shall be applied to the depth shown on the Drawings. Concrete mortar for this finish shall be in accordance with the following schedule:

<u>Material</u>	<u>Volumes</u>	<u>Weights</u>
Cement	1.0	2.00
Embeco	0.2	0.33
Sand	1.0	1.00
Pea Gravel	1.5	1.50

SECTION 03300 – 3.11

The size of the coarse aggregate shall not exceed  $\frac{3}{4}$  inch. The surface receiving the mortar finish shall be thoroughly cleaned of all debris, dirt, grease and other foreign matter by brooming with a clean broom and flushed with a strong jet of water. Before placing the finish, all pools of water left by the cleaning operation shall be removed by mopping or air jet and a thin ( $\frac{1}{16}$  inch –  $\frac{1}{8}$  inch) coat of thick creamy net cement slurry shall be broomed into the surface a short distance ahead of the finish-placing operation. The finish shall be applied immediately, before the grout has dried or hardened.

E. Mortar shall be placed in the circular tank bottoms and screed to a true surface.

## SECTION 03310 – CONCRETE – GENERAL

### PART I – GENERAL

#### 1.01 SCOPE OF WORK

A. The Contractor shall furnish all labor, tools, materials, equipment and incidentals required to provide concrete where specified for this project.

#### 1.02 RELATED WORK

- A. Refer to Section 03100 – Concrete Formwork
- B. Refer to Section 03200 – Concrete Reinforcement
- C. Refer to Section 03300 – Cast-in-Place Concrete
- D. Refer to Section 01 45 29 Testing Laboratory Services

#### 1.03 DESCRIPTION OF SYSTEM

A. This section establishes general criteria for materials, mixes and evaluations of concrete as required for other related sections of these Specifications.

#### 1.04 QUALITY ASSURANCE

##### A. Codes and Standards

1. Comply with the provisions of the following codes, specifications and standards, except as otherwise shown or specified.

- a. ACI 301 – “Specifications for Structural Concrete for Buildings”
- b. ACI 304 – “Recommended Practice for Measuring, Mixing, Transporting and Placing Concrete”
- c. ACI 305 – “Recommended Practice for Hot Weather Concreting”
- d. ACI 306 – “Recommended Practice for Cold Weather Concreting”
- e. ACI 308 – “Recommended Practice for Curing Concrete”
- f. ACI 311 – “Recommended Practice for Concrete Inspection”
- g. ACI 318 – “Building Code Requirements for Reinforced Concrete”

2. Where provisions of the above codes and standards are in conflict with the Uniform Building Code and New York State in force for this project, the building code shall govern.

SECTION 03310 – 1.04

1.05 TESTS FOR CONCRETE MATERIALS

A. For normal weight concrete, test aggregates by the methods of sampling and testing of ASTM C 33.

B. For Portland cement, conform to ASTM C 150.

1.06 QUALITY CONTROL TESTING DURING CONSTRUCTION

A. Concrete shall be sampled and tested for quality control during the placement of concrete, as follows:

1. Sampling fresh concrete: ASTM C 172, except modified for slump to comply with ASTM C 94.

2. Slump: ASTM C 143; one test for each concrete load at point of discharge; and one for each set of compressive strength test specimens.

3. Air content: ASTM C 231, pressure method; one for each set of compressive strength test specimens.

B. Compression Test Specimens

1. ASTM C31; one set of four (4) standard cylinders for each compressive strength test, unless otherwise directed. Mold and store cylinders for laboratory cured test specimens except when field-cured test specimens are required.

C. Concrete Temperature

1. Test hourly when air temperature is 40 degrees F. and below, and when 80 degrees F. and above; and each time a set of compression test specimens made.

D. Compressive Strength Tests

1. ASTM C 39; one set for each truck load of concrete or fraction thereof, of each concrete class placed in any one day; one specimen tested at 7 days, two specimens tested at 28 days, and one specimen retained in reserve for later testing if required.

2. When the total quantity of a given class of concrete is less than 10 cubic yards, the strength tests may be waived by the Engineer if, in his judgment, adequate evidence of satisfactory strength is provided.

SECTION 03310 – 1.06

3. When the strength of field-cured cylinders is less than 85% of companion laboratory-cured cylinders, evaluate current operations and provide corrective procedures for protecting and curing the in-place concrete.

E. Testing Reports

1. Report test results in writing to the Engineer and the Contractor on the same day that tests are made. Reports of compressive strength tests shall contain the project identification name and number, date of concrete placement, name of contractor, name of concrete supplier and truck number, name of concrete testing service, concrete type and class, location of concrete batch in the structure, design compressive strength at 28 days, concrete mix proportions and materials; compressive breaking strength and type of break for both 7-day and 28-day tests, air content, actual slump and concrete temperature.

F. Core Tests

1. The testing service shall take core samples of in-place concrete when test results are such that there is reasonable doubt that the specified concrete strengths and other characteristics have not been attained in the structure, as directed by the Engineer. The testing service shall conduct tests to determine the strength and other characteristics of the in-place concrete by compression tests on cored cylinders complying with ASTM C 42, or by load testing specified in ACI 318, or others as directed. The Contractor shall pay for such tests conducted and any other additional testing as maybe required. Petrographic studies or cores shall be performed as directed by the Engineer. This work shall be paid for by the Contractor.

1.07 WORKMANSHIP

A. Concrete work which does not conform to the specified requirements, including strength, tolerances and finishes, shall be corrected as directed by the Engineer at the Contractor's expense, without extension of time therefore. The Contractor shall also be responsible for the cost of corrections to any other work affected by or resulting from corrections to the concrete work.

B. Structures designed and intended to resist water or liquid pressure shall be made watertight by the Contractor to conform with the following requirements. When the structures are loaded with sewage or other liquids, any cracks or leaks shall be repaired. If the structure does not stop leaking to the satisfaction of the Engineer, the Contractor shall repair or replace, at his own expense, such part of the work as may be necessary to secure the desired results.

## SECTION 03310 – 1.08

### 1.08 SUBMITTALS

#### A. Manufacturer's Data, Concrete – General

1. For information only, submit two copies of manufacturer's specifications with application and installation instructions for proprietary materials and items, including admixtures, bonding agents, waterstops, joint systems, dry shake finish materials and non-shrink grout.

#### B. Samples, Concrete – General

1. Submit samples of materials as specified and as otherwise may be requested by the Engineer, including names, sources and descriptions as required.

## SECTION 03310 – 1.08

#### C. Laboratory Test Reports, Concrete – General

1. Submit two copies of laboratory test reports for concrete materials and mix design tests. The Engineer's review will be for general information only. Production of concrete to comply with specified requirements is the Contractor's responsibility.

## PART II – PRODUCTS

### 2.01 CONCRETE MATERIALS

#### A. Portland Cement: ASTM C 150, as follows:

- 1a. Provide Type I cement for use in general concrete construction where low heat of hydration is not required and where no sulfate action is anticipated.
- 1b. Provide Type II cement for use in general concrete construction subjected or adjacent to sewage, sludge, effluent, etc.
- 1c. Provide Type III cement for use when high early strength is required for replacement of public pavements and commercial driveways.
2. Use only one brand of cement for each required type throughout the project, unless otherwise accepted by the Engineer.
3. A pozzolan material shall NOT be used.

## SECTION 03310 – 2.01

B. Aggregates, Normal Weight Concrete: ASTM C 33, and as herein specified.

1. Final Aggregate

- a. Clean, sharp, natural sand free from loam, clay, lumps or other deleterious substances.
- b. Dune sand, bank run sand and manufactured sand are not acceptable.

2. Coarse Aggregate: Clean, uncoated, processed aggregate containing no clay, mud, loam, or foreign matter, as follows:

- a. Crushed limestone processed from natural rock or stone.
- b. Maximum aggregate size – not larger than one-fifth of the narrowest dimension between sides of forms, one-third of the depth of slabs, nor three-fourths of the minimum clear spacing between individual reinforcing bars or bundles or bars.
- c. These limitations may be waived if, in the judgment of the Engineer, workability and methods of consolidation are such that concrete can be placed without honeycomb or void.

3. Supply of Aggregates

- a. Provide aggregates from one source of supply to ensure uniformity in color, size and shape.
- b. Do not use aggregates containing soluble salts or other substances such as iron sulphides, pyrite, marcasite or ochre which can cause stains on exposed concrete surfaces.

C. Water

1. Clean, fresh, free from oil, acid, organic matter or other deleterious substances.

## 2.02 CONCRETE ADMIXTURES

A. Provide admixtures produced by acceptable manufacturers and use in compliance with the manufacturer's printed directions. Do not use admixtures which have not been incorporated and tested in the accepted mixes, unless otherwise authorized in writing by the Engineer.



SECTION 03310 – 2.02

B. Air-Entraining Admixture: ASTM C 260 shall be used in all concrete to attain the specified air entrainment.

1. Products offered by manufactures to comply with the requirements for air-entraining admixture include the following:

- a. Darex AEA; Dewey and Almy Chemical Div. of W.R. Grace
- b. Sika AER; Sika Chemical Corp.
- c. MB-VR; Master Builder's Co.
- d. Or equal

C. Water-Reducing Admixture: ASTM C 494 shall be used in all concrete. When approved by the Engineer, retarding or acceleration formulations of the same product may be used.

SECTION 03310 – 2.02

1. Products offered by manufacturers to comply with the requirements for water-reducing admixture include the following:

- a. Plastiment by Sika Chemical Corp.
- b. SRDA: Dewey and Almy Chemical Div. Of W.R. Grace
- c. Pozzolith; Master Builder's Co.
- d. Or equal

D. Calcium Chloride: Do not use calcium chloride in concrete, unless otherwise authorized in writing by the Engineer.

2.03 PROPORTIONING AND DESIGN OF MIXES

A. Prepare design mixes for each type of concrete. Use an independent testing facility acceptable to the Engineer for preparing and reporting proposed mix designs. The testing facility shall not be the same as used for field quality control testing.

B. Proportion mixes by laboratory trial batch method, using materials to be employed on the project for each class of concrete required, complying with ACI 211.1 for normal weight and report to the Engineer for the following data:

1. Complete identification of aggregate source of supply.
2. Tests of aggregates for compliance with specified requirements.
3. Scale weight of each aggregate.
4. Brand, type of cement.
5. Brand, type and amount of each admixture.

SECTION 03310 – 2.03

6. Amounts of water used in trial mixes.
7. Proportions of each material per cubic yard.
8. Gross weight and yield per cubic yard of trial mixtures.
9. Measured slump.
10. Measured air content.
11. Theoretical yield.
12. Mix temperature.
13. Water-cement ratio.

Compressive strength developed at 7 days and 28 days, from not less than 3 test cylinders cast for the 7 and 28 day test, and for each design mix.

C. Reports

1. Submit written reports to the Engineer of each proposed mix for each class of concrete at least 15 days prior to start of work. Do not begin concrete production until mixes have been reviewed by the Engineer.

D. Laboratory Trial Batches

1. When laboratory trial batches are used to select concrete proportions, prepare test specimens in accordance with ASTM C 192 and conduct strength tests in accordance with ASTM C 39, as specified in ACI 301.

2. Establish a curve showing relationship between water-cement ratio (or cement content) and compressive strength, with at least 3 points representing batches which produce strengths above and below that required. Use not less than 2 specimens tested at 28-days, or an earlier age when acceptable to the Engineer, to establish each point on the curve. Proportions shall be taken from the cure at a point 1200 psi above the design strength.

E. Adjustable to Concrete Mixes

1. Mix design (w/c ratio) adjustments may be requested by the Contractor when characteristics of materials, job conditions, weather, test results, or other circumstances warrant, at no additional cost to the Owner and as accepted by the Engineer. Laboratory test data for revised mix designs and strength results must be submitted to and accepted by the Engineer before using in the work.

2.04 ADMIXTURES

A. Use air-entraining admixtures in all concrete, unless otherwise shown or specified. Add air-entraining admixture at the manufacturer's prescribed rate to result in concrete at the point of placement having air content within the following limits:

SECTION 03310 – 2.04

1. Concrete structures and slabs exposed to freezing and thawing or subjected to hydraulic pressure (air content as determined in accordance with ASTM C 231 or C 173):

- a.  $5 \pm 1$  percent for coarse aggregate size No. 467
- b.  $6 \pm 1$  percent for coarse aggregate size No. 57 or 67

B. Use water-reducing admixtures in all concrete in strict compliance with the manufacturer's directions. Admixtures to increase cement dispersion, or provide increased workability for low-slump concrete, may be used at the Contractor's option subject to the Engineer's acceptance.

1. Use amounts of admixtures as recommended by the manufacturer for climatic conditions prevailing at the time of placing. Adjust quantities of admixtures as required to maintain quality control.

C. Slump Limits (as determined in accordance with ASTM C 143):

- 1. 1 inch maximum
- 2. 3 inch maximum for footings, caissons, substructure walls
- 3. 4 inch maximum for slabs, beams, reinforced walls, columns

2.05 CONCRETE STRENGTH

A. There shall be two classes of concrete, 4000 psi at 28 days with maximum water-cement ratio of 0.45 and 2000 psi at 28 days with maximum water-cement ratio of 0.75.

B. The 2000 psi concrete is intended principally for pipe cradle and encasement or for backfill of unauthorized excavation. All other concrete, including all thrust blocks, shall be 4000 psi.

C. Minimum cement content:

<u>Coarse Aggregate No.</u>	<u>Lb. Per Cu. Yd.</u>
467 (1 ½ inch maximum)	517
57 (1 inch maximum)	564
67 (¾ inch maximum)	564

PART III – EXECUTION

3.01 CONCRETE EVALUATIONS

A. Evaluation of Quality Control Tests

SECTION 03310 – 3.01

1. The concrete quality control testing as specified in Part I will be evaluated by the following criteria:

- a. Do not use concrete delivered to the final point of placement which has slump or total air content outside the specified values.

B. Compressive strength tests for laboratory-cured cylinders will be considered satisfactory if the average of each set of two consecutive compressive strength tests results equal or exceed the 28-day design compressive strength of the type or class of concrete; and, no individual strength test falls below the required compressive strength by more than 500 psi.

1. Strength tests of specimens cured under field conditions may be required by the Engineer to check the adequacy of curing and protecting of the concrete placed. Mold these specimens at the same time and from the same samples as the laboratory cured specimens, as directed by the Engineer.

2. Provide improved means and procedures for protecting concrete when the 28-day compressive strength of field-cured cylinders is less than 85% of companion laboratory-cured cylinders.

3. When laboratory-cured cylinder strengths are appreciably higher than the minimum required compressive strength, field-cured cylinder strengths need not exceed the minimum required compressive strength by more than 500 psi even though the 85% criterion is not met.

4. If individual tests of laboratory-cured specimens produce strengths more than 500 psi below the required minimum compressive strength, or if tests of field-cured cylinders indicate deficiencies in protection and curing, provide additional measures to assure that the load-bearing capacity of the structure is not jeopardized. If the likelihood of low-strength concrete is confirmed and computations indicate the load-bearing capacity may have been significantly reduced, tests of cores drilled from the area in question may be required.

5. If the compressive strength tests fail to meet the minimum requirements specified, the concrete represented by such tests will be considered deficient in strength and subject to additional testing as herein specified.

C. Formed Concrete Dimensional Tolerances

1. Formed concrete having any dimension smaller or greater than required, and outside the specified tolerance limits, will be considered deficient in strength and subject to additional testing as herein specified.

SECTION 03310 – 3.01

2. Formed concrete having any dimension greater than required will be rejected if the appearance or function of the structure is adversely affected, or if the larger dimensions interfere with other construction. Repair, or remove and replace rejected concrete as required to meet the construction conditions. When permitted, accomplish the removal of excessive material in a manner to maintain the strength of the section without affecting function and appearance.

D. Strength of Concrete Structures

1. The strength of the concrete structure in-place will be considered potentially deficient if it fails to comply with any of the requirements which control the strength of structure, including the following conditions:

- a. Failure to meet compressive strength test requirements.
- b. Concrete which differs from the required dimensions or location in such a manner to reduce strength
- c. Concrete subjected to damaging mechanical disturbances; particularly load stresses, heavy shock, and excessive vibration.
- d. Poor workmanship and quality control likely to result in deficient strength.

E. Testing Concrete Structure for Strength

1. When there is evidence that the strength of the concrete structure in-place does not meeting specification requirements, the concrete testing service shall take cores drilled from hardened concrete for compressive strength determination, complying with ASTM C 42 and as follows:

- a. Take at least three representative cores from each member or area of suspect strength, from locations directed by the Engineer.
- b. Test cores in a saturated-surface-dry condition per ACI 318 if the concrete will be wet during the use of the completed structure.
- c. Test cores in an air-dry condition per ACI 318 if the concrete will be dry at all times during use of the completed structure.

SECTION 03310 – 3.01

2. Strength of concrete for each series of cores will be considered satisfactory if their average compressive strength is at least 90% and no single core is less than 75% of the 28-day required compressive strength.

3. Report test results in writing to the Engineer on the same day that tests are made. Include in test reports that project identification name and number, date, name of Contractor, name of concrete testing service, location of test core in the structure, type or class of concrete represented by core sample, nominal maximum size aggregate, design compressive strength, compression breaking strength and type of break (corrected for length-diameter ratio), direction of applied load to core with respect to horizontal plane of the concrete as placed, and the moisture condition of the core at time of testing.

4. Fill core holes solid with non-shrink mortar, and finish to match adjacent concrete surfaces.

5. Conduct static load test and evaluations complying with ACI 318 if the results of the core tests are unsatisfactory, or if core tests are impracticable to obtain, as directed by the Engineer.

6. Correct all concrete work that is found structurally inadequate by core tests or by results of static load tests, as directed by the Engineer.

## APPENDIX "A"

Erie County Std Detail #	List of Standard Detail Name	Page #
1	Unsheeted Trench Detail	1
1A	Trenching "Undercut" Detail	2
ISR	Unsheeted Trench Detail For Spot Repairs	3
2	Sheeted Trench	4
3	Rock Trench Detail	5
4	Select Backfill for Trench Parallel to Roadways	6
5	Watermain Crossing Detail Typical for Encasement	7
6	Typical Concrete Encasement Detail	8
7	Concrete Cradle Detail	9
8	Pavement and Driveway Replacement Detail	10
9	Pipe Crossing Support Detail	11
10	Monolithic Precase Base Manholes 4'-0" Dia. Base for 15" Diameter Sewers or Less	12
11	Monolithic Precase Base Manholes 4'-0" Dia. Base for 15" Diameter Sewers or Less (Section B-B)	13
12	Monolithic Precase Base Manholes Pipe Size 18" Diameter Thru 36" Diameter	14
13	Standard Frame and Cover	15
14	Forcemain Trench Detail	16
17	Standard Manhole Step	17
18	Inside Drop Pipe	18
19	Manhole Vent Detail	19
20	Tree Removal and Replacement Policy	20
21	Typical House Service Detail	21
21/22A	Tapping Lined Pipes	22
21/22B	Tap Saddle Detail for CIPP-Lined Pipes	23
24	Typical Cross Section of Highway Crossing for House/Commercial Laterals	24
28	Clean-Out Detail for Service Connection	25
32A	Grinder Pump Force Main Connection to Gravity Sewer Line Detail	26
33	Sanitary Sewer Pipe & Manhole Abandonment	27
35	Precast Doghouse Base Manhole	28
37	Connection to Existing Manhole	29
52	Existing Cleanout Removal	30
53	Cleanout in Pavement/Sidewalks Non Residential and Commercial Projects	31
54	Cleanout Detail End of Line	32
55	Clay Dam Relief Pipe	33
-	Catch Basin w/ Riser Detail (24" x 24")	34
-	Lawn Drain	35

# UNSHEETED TRENCH DETAIL

(JANUARY 2012)

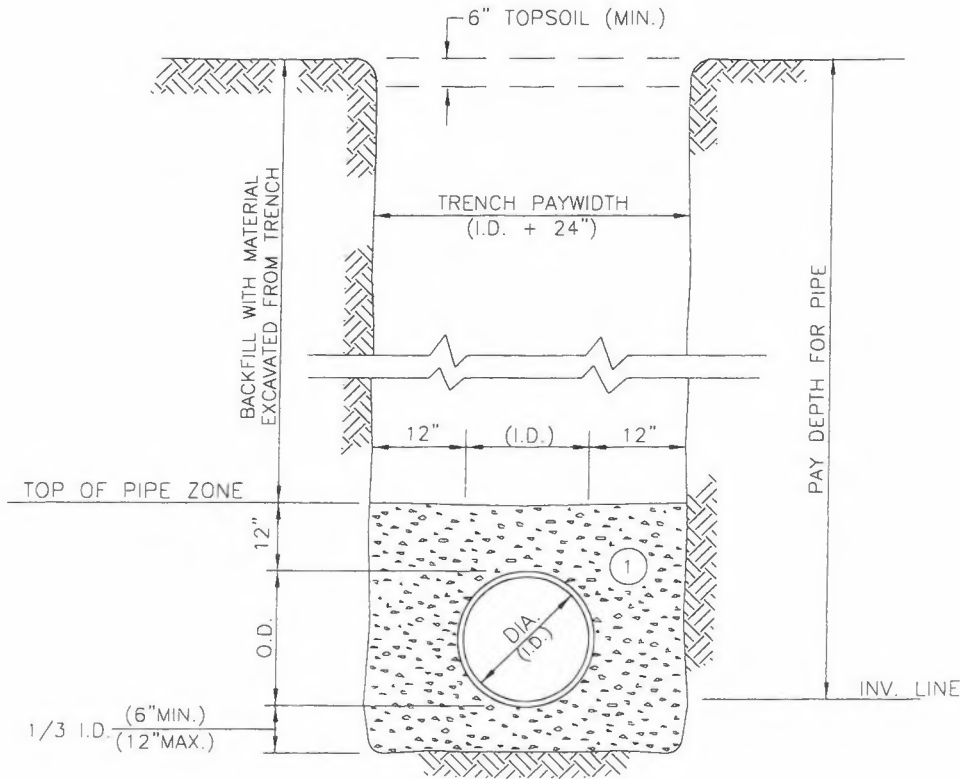

**NOTES:**

- A. PIPE INSTALLATION SHALL BE IN ACCORDANCE WITH MANUFACTURERS RECOMMENDATIONS.
- B. TRENCHING OPERATIONS SHALL INCLUDE ALL NECESSARY DEWATERING.
- C. TRENCH DETAILS ARE ONLY SHOWN FOR PURPOSES OF MATERIAL PLACEMENT AND MAXIMUM PAY LIMITS.
- D. AN OSHA APPROVED MOVABLE PROTECTIVE TRENCH SHIELD SHALL BE USED IN ALL UNSHEETED TRENCH AREAS.

**MATERIALS**

PIPE BEDDING MATERIAL (NYS DOT LATEST EDITION)

① NO.1 CRUSHED STONE WITH A GRADATION CONFORMING WITH NYS DOT SECTION 703-02. THE CRUSHED STONE SHALL BE WELL GRADED WITH NO PARTICLES LARGER THAN 1" AND HAVING A MAXIMUM GRADATION MEETING THE LIMITS DESCRIBED IN THE SPECIFICATIONS. THE BEDDING SHALL BE COMPACTED IN 6" LIFTS WITH EQUIPMENT ACCEPTABLE TO THE PIPE MANUFACTURER.

NOTE: SLAG SHALL NOT BE ALLOWED FOR MATERIALS ①

ERIE COUNTY DEPT. OF ENVIRONMENT & PLANNING DIVISION OF SEWERAGE MANAGEMENT	Rev. 1 5/20/93	NOTE 2: PIPE INSTALLATION	1
	Rev. 2 2/7/94	ADDED NOTE C & D	
	File: d-01	Date: 3/1/91	



# TRENCHING "UNDERCUT" DETAIL

(JANUARY 2012)

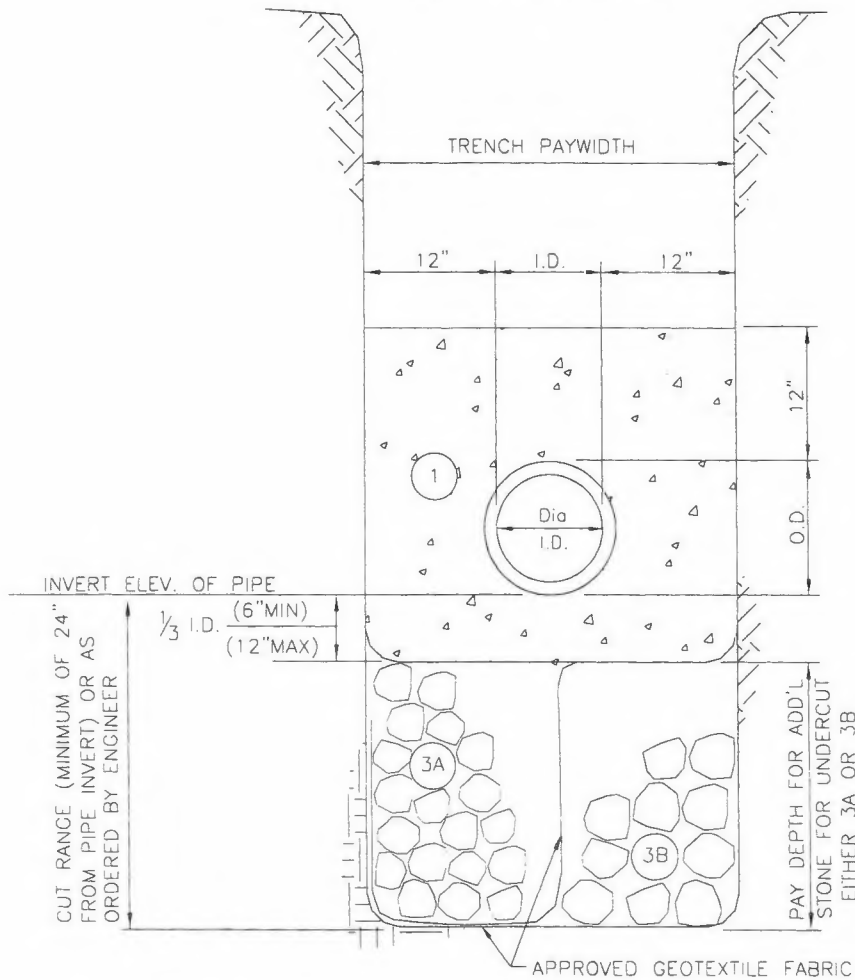

**NOTE:**

- A. TRENCH DETAILS ARE ONLY SHOWN FOR PURPOSES OF MATERIAL PLACEMENT AND MAXIMUM PAY LIMITS.
- B. AN OSHA APPROVED MOVABLE PROTECTIVE TRENCH SHIELD SHALL BE USED IN ALL UNSHEETED TRENCH AREAS.

**MATERIALS**

PIPE BEDDING MATERIAL (NYSOT LATEST EDITION)

- ① NO.1 CRUSHED STONE WITH A GRADATION CONFORMING WITH NYSDOT SECTION 703-02. THE CRUSHED STONE SHALL BE WELL GRADED WITH NO PARTICLES LARGER THAN 1" AND HAVING A MAXIMUM GRADATION MEETING THE LIMITS DESCRIBED IN THE SPECIFICATIONS. THE BEDDING SHALL BE COMPACTED IN 6" LIFTS WITH EQUIPMENT ACCEPTABLE TO THE PIPE MANUFACTURER.

SELECT MATERIAL BACKFILL (NYSOT LATEST EDITION)

- ③A NO. 3 RUN OF CRUSHER STONE WITH A GRADATION CONFORMING WITH NYSDOT SECTION 304-2.02 TYPE 1 AND NYSDOT SECTION 703-02. COMPACTED IN 6" LIFTS WITH APPROVED GEOTEXTILE FABRIC.
  - OR
  - ③B NO. 4 RUN OF CRUSHER STONE CONFORMING WITH THE GRADATION NOTED IN NYSDOT SECTION 703-02, TABLE 703-4 SIZE DESIGNATION 4.
- NO SLAG SHALL BE ALLOWED FOR MATERIALS ① ③A & ③B

ERIE COUNTY DEPT. OF ENVIRONMENT & PLANNING DIVISION OF SEWERAGE MANAGEMENT	Rev. 1	ADDED SELECT FILL	STD.DETAIL  <span style="font-size: 2em;">1A</span>
	12/2001	MATERIAL 3A & 3B	
	Rev. 2		Date: 3/2/99
		File: D-01a	

# UNSHEETED TRENCH DETAIL FOR SPOT REPAIRS (NOVEMBER 2023)

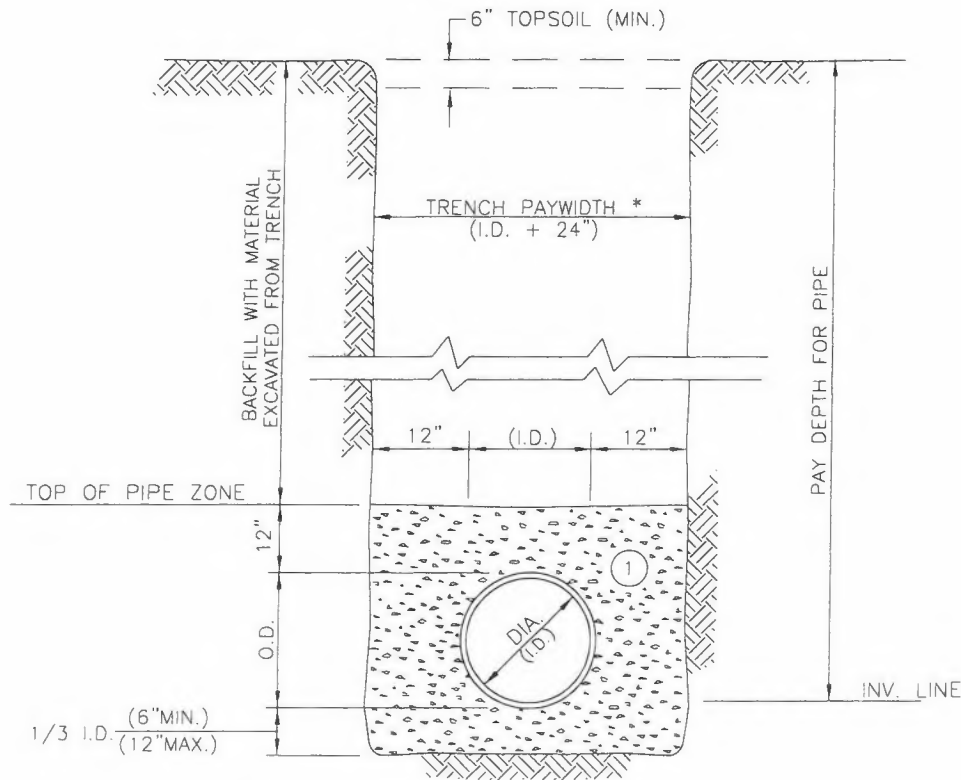

\* PAY WIDTHS OF UP TO 48" WIDE TOTAL MAY BE AUTHORIZED BY THE ENGINEER FOR SPOT REPAIRS TO ACCOUNT FOR CONTRACTORS LOCATION OF REPAIR AREA/DEFECTS.

- NOTES:
- A. PIPE INSTALLATION SHALL BE IN ACCORDANCE WITH MANUFACTURERS RECOMMENDATIONS.
  - B. TRENCHING OPERATIONS SHALL INCLUDE ALL NECESSARY DEWATERING.
  - C. TRENCH DETAILS ARE ONLY SHOWN FOR PURPOSES OF MATERIAL PLACEMENT AND MAXIMUM PAY LIMITS.
  - D. AN OSHA APPROVED MOVABLE PROTECTIVE TRENCH SHIELD SHALL BE USED IN ALL UNSHEETED TRENCH AREAS.

### MATERIALS

#### PIPE BEDDING MATERIAL (NYS DOT LATEST EDITION)

- ① NO.1 CRUSHED STONE WITH A GRADATION CONFORMING WITH NYS DOT SECTION 703-02. THE CRUSHED STONE SHALL BE WELL GRADED WITH NO PARTICLES LARGER THAN 1" AND HAVING A MAXIMUM GRADATION MEETING THE LIMITS DESCRIBED IN THE SPECIFICATIONS. THE BEDDING SHALL BE COMPACTED IN 6" LIFTS WITH EQUIPMENT ACCEPTABLE TO THE PIPE MANUFACTURER.

NOTE: SLAG SHALL NOT BE ALLOWED FOR MATERIALS ①

V:\DSM\Engineering\CAD\Details\Details November 2023\D-01SR.dwg, Model, 2023/11/20 11:04 am

**ERIE COUNTY**  
**DEPT. OF ENVIRONMENT & PLANNING**  
**DIVISION OF SEWERAGE MANAGEMENT**

Rev. 1	5/93	NOTE 2: PIPE INSTALLATION
Rev. 2	2/94	ADDED NOTE C & D
Rev. 3	1/23	ADDED * FOR SPOT REPAIRS WIDTHS
File: D-01SR		Date: Nov-2023

STD.DETAIL  
**1SR**

# SHEETED TRENCH

## (JANUARY 2012)

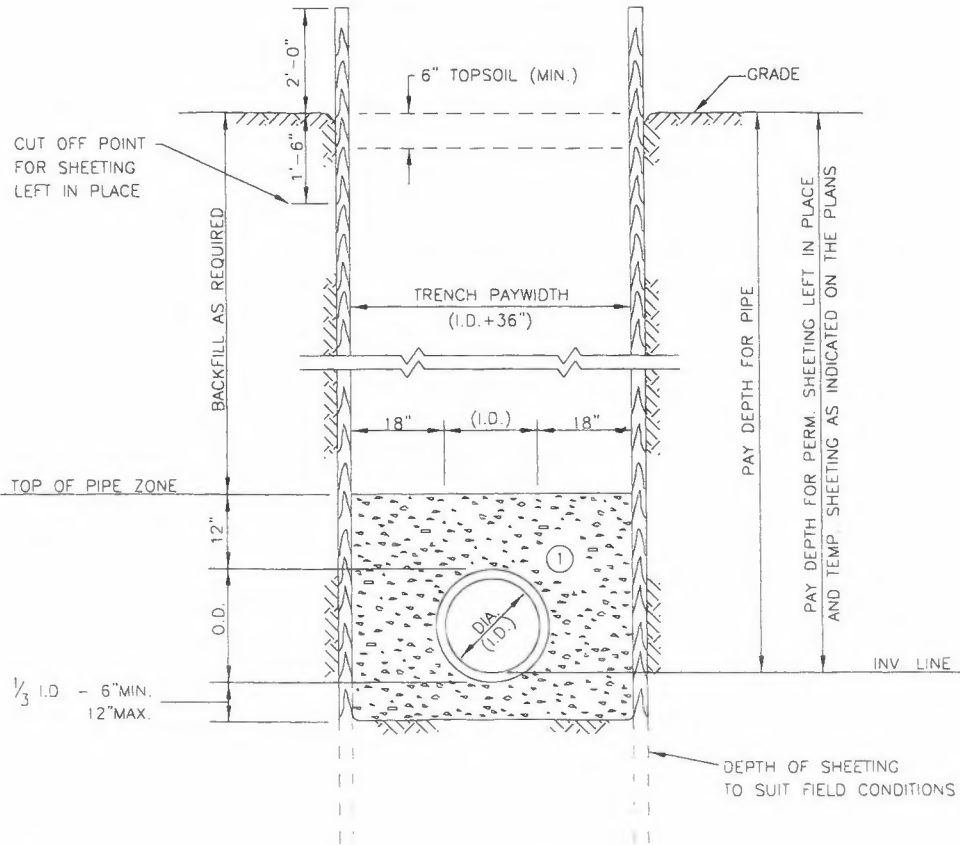

**NOTES:**

1. MAINTAIN 18" BETWEEN PIPE AND INSIDE FACE OF TEMPORARY SHEETING. IF SHEETING EXTENDS BELOW PIPE INVERT AS SHOWN. WHEN PVC PIPE MATERIAL IS USED, COMPACT MATERIAL ① BEFORE PULLING THE SHEETING
2. SHEETED TRENCH OPERATIONS SHALL INCLUDE ALL NECESSARY DEWATERING EQUIPMENT
3. SHEETING DRIVEN BELOW THE INVERT OF THE PIPE FOR BEDDING MATERIAL AND TOE SUPPORT WILL NOT BE CONSIDERED IN THE FORMULA FOR PAYMENT BUT SHOULD BE FIGURED BY THE CONTRACTOR IN DETERMINING HIS UNIT BID PRICE PER SQUARE FOOT OF SHEETING.
4. WHERE INDICATED ON THE PLANS OR AS ORDERED BY THE ENGINEER, TEMPORARY SHEETING WILL BE PAID FOR UNDER THE APPLICABLE BID ITEM. OTHER AREAS WHERE THE CONTRACTOR ELECTS TO USE TEMPORARY SHEETING NOT PREVIOUSLY AUTHORIZED BY THE ENGINEER SHALL BE AT HIS OPTION AND EXPENSE

**MATERIALS**

**PIPE BEDDING MATERIAL (NYS DOT LATEST EDITION)**

- ① NO.1 CRUSHED STONE WITH A GRADATION CONFORMING WITH NYS DOT SECTION 703-02. THE CRUSHED STONE SHALL BE WELL GRADED WITH NO PARTICLES LARGER THAN 1" AND HAVING A MAXIMUM GRADATION MEETING THE LIMITS DESCRIBED IN THE SPECIFICATIONS. THE BEDDING SHALL BE COMPACTED IN 6" LIFTS WITH EQUIPMENT ACCEPTABLE TO THE PIPE MANUFACTURER.

NOTE: SLAG SHALL NOT BE ALLOWED FOR MATERIALS ①

ERIE COUNTY  
DEPT. OF ENVIRONMENT & PLANNING  
DIVISION OF SEWERAGE MANAGEMENT

Rev. 1	REVISED TOPSOIL DIMENSION	STD.DETAIL
2/7/94		
Rev. 2	UPDATED MATERIALS TO NYS DOT LATEST EDITION	2
6/5/06		
File:	d-02	Date: 3/1/91

# ROCK TRENCH DETAIL

(JANUARY 2012)

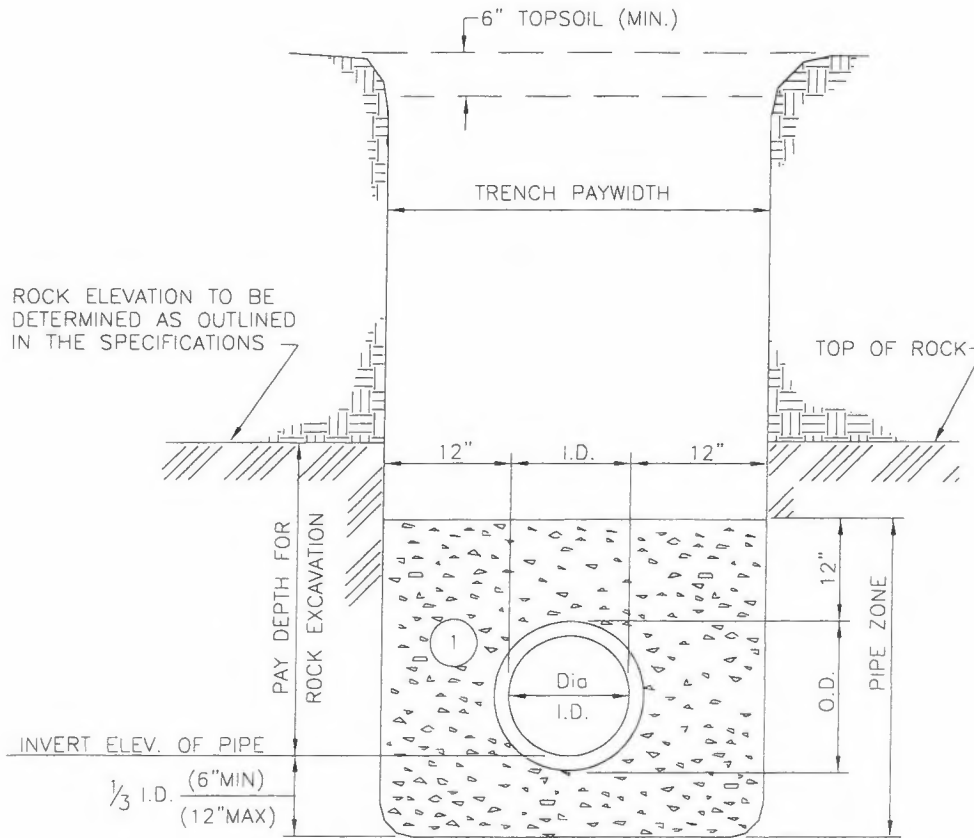

**NOTE:**

- A. TRENCH DETAILS ARE ONLY SHOWN FOR PURPOSES OF MATERIAL PLACEMENT AND MAXIMUM PAY LIMITS.
- B. AN OSHA APPROVED MOVABLE PROTECTIVE TRENCH SHIELD SHALL BE USED IN ALL UNSHEETED TRENCH AREAS.

**MATERIALS**

**PIPE BEDDING MATERIAL (NYS DOT LATEST EDITION)**

- ① NO.1 CRUSHED STONE WITH A GRADATION CONFORMING WITH NYS DOT SECTION 703-02. THE CRUSHED STONE SHALL BE WELL GRADED WITH NO PARTICLES LARGER THAN 1" AND HAVING A MAXIMUM GRADATION MEETING THE LIMITS DESCRIBED IN THE SPECIFICATIONS. THE BEDDING SHALL BE COMPACTED IN 6" LIFTS WITH EQUIPMENT ACCEPTABLE TO THE PIPE MANUFACTURER.

NOTE: SLAG SHALL NOT BE ALLOWED FOR MATERIALS ①

<b>ERIE COUNTY</b> <b>DEPT. OF ENVIRONMENT &amp; PLANNING</b> <b>DIVISION OF SEWERAGE MANAGEMENT</b>	Rev. 1	ADDED 6" TOPSOIL (MIN.)	<b>STD.DETAIL</b>  <span style="font-size: 2em;">3</span>
	1/6/94		
	Rev. 2	ADDED NOTES A & B	
	2/7/94		
	File: d-03	Date: 3/1/91	

# SELECT BACKFILL FOR TRENCH PARALLEL TO ROADWAYS (NOVEMBER 2023)

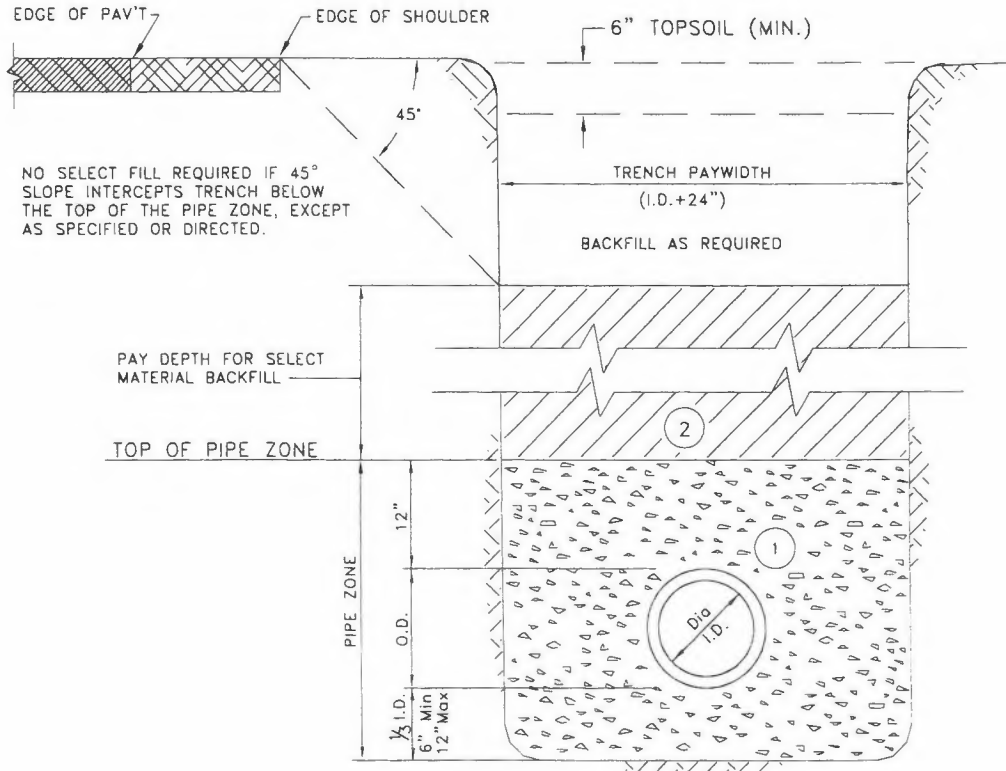

NO SELECT FILL REQUIRED IF 45° SLOPE INTERCEPTS TRENCH BELOW THE TOP OF THE PIPE ZONE, EXCEPT AS SPECIFIED OR DIRECTED.

**NOTE:**

- A. TRENCH DETAILS ARE ONLY SHOWN FOR PURPOSES OF MATERIAL PLACEMENT AND MAXIMUM PAY LIMITS.
- B. AN OSHA APPROVED MOVABLE PROTECTIVE TRENCH SHIELD SHALL BE USED IN ALL UNSHEETED TRENCH AREAS.

### MATERIALS

PIPE BEDDING MATERIAL (NYS DOT LATEST EDITION)

- ① NO. 1 CRUSHED STONE WITH A GRADATION CONFORMING WITH NYSDOT SECTION 703-02. THE CRUSHED STONE SHALL BE WELL GRADED WITH NO PARTICLES LARGER THAN ONE INCH AND HAVING A MAXIMUM GRADATION MEETING THE LIMITS DESCRIBED IN THE SPECIFICATIONS. THE BEDDING SHALL BE COMPACTED IN 6" LIFTS WITH EQUIPMENT ACCEPTABLE TO THE PIPE MANUFACTURER.

SELECT MATERIAL BACKFILL (NYS DOT LATEST EDITION)

- ② NO. 2 RUN OF CRUSHER STONE OR NO. 2 RUN OF CRUSHER GRAVEL WITH A GRADATION CONFORMING WITH NYSDOT STANDARD SPECIFICATION, 304.12 - TYPE 2 SUBBASE (COMPACTED IN 6" LIFTS TO 95% DENSITY)

NO SLAG SHALL BE ALLOWED FOR MATERIALS ① & ②

V:\DSM\Engineering\CAD\Details\November 2023\11/20 11:16 am

**ERIE COUNTY  
DEPT. OF ENVIRONMENT & PLANNING  
DIVISION OF SEWERAGE MANAGEMENT**

Rev. 2	12/00	UPDATED NYS DOT EDITIONS
Rev. 3	12/01	UPDATED NYS DOT EDITIONS
Rev. 4	11/23	UPDATED NYS DOT EDITIONS
File: D-04		Date: 3/1/91

STD.DETAIL

4

# WATERMAIN CROSSING DETAIL TYPICAL FOR ENCASEMENT (JANUARY 2012)

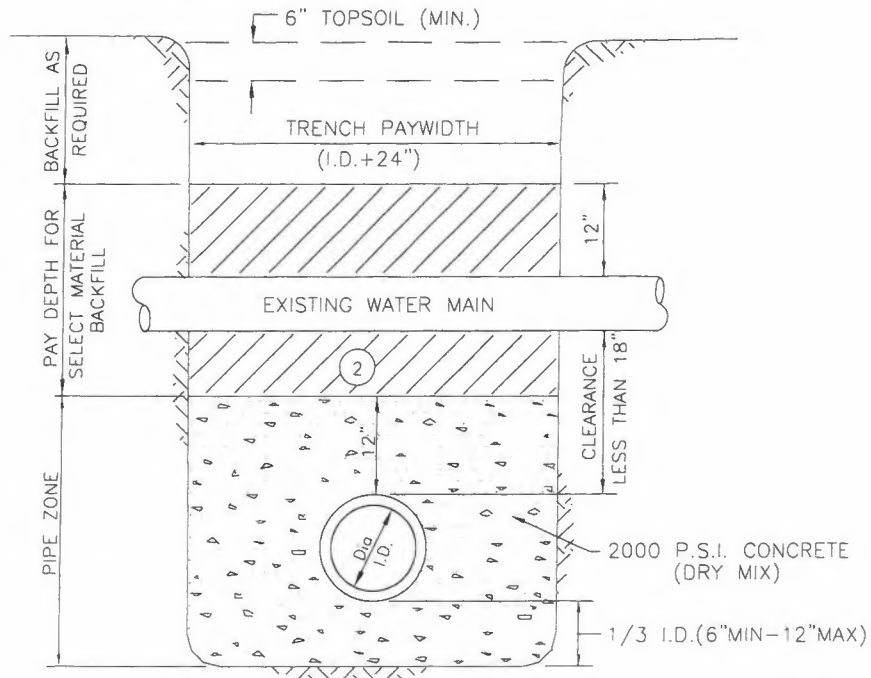

**NOTES:**

- A. IN ALL CASES WHERE THERE IS LESS THAN 18" CLEARANCE BETWEEN EXISTING WATER MAIN AND PROPOSED SEWER (INCLUDING HOUSE LATERALS) THE NEW WORK SHALL BE ENCASED IN CONCRETE AS SHOWN. WHEN A CASING PIPE IS SPECIFIED, NO CONCRETE ENCASEMENT IS REQUIRED.
- B. THE CONCRETE ENCASEMENT SHALL EXTEND 3'-0" EACH SIDE OF THE WATER MAIN.
- C. SEWERS SHALL BE LAID AT LEAST 10' (3.0 m) HORIZONTALLY FROM ANY EXISTING OR PROPOSED WATERMAIN. THE DISTANCE SHALL BE MEASURED EDGE TO EDGE. IN CASES WHERE IT IS NOT PRACTICAL TO MAINTAIN A 10' SEPARATION, THE APPROPRIATE REVIEWING AGENCY MAY ALLOW DEVIATION ON A CASE BY CASE BASIS, IF SUPPORTED BY DATA FROM THE DESIGN ENGINEER. SUCH DEVIATION MAY ALLOW INSTALLATION OF THE SEWER CLOSER TO A WATERMAIN, PROVIDED THE WATERMAIN IS IN A SEPARATE TRENCH OR ON AN UNDISTURBED EARTH SHELF LOCATED ON ONE SIDE OF THE SEWER AND THE ELEVATION OF THE BOTTOM OF THE WATERMAIN IS AT LEAST 18" (46 cm) ABOVE THE TOP OF SEWER.
- D. SEWERS CROSSING WATERMAINS SHALL BE LAID TO PROVIDE MINIMUM VERTICAL DISTANCE OF 18" (46 CM) BETWEEN THE OUTSIDE OF THE WATERMAIN AND THE OUTSIDE OF THE SEWER. THIS SHALL BE THE CASE WHEN THE WATERMAIN IS ABOVE OR BELOW THE SEWER. THE CROSSING SHALL BE ARRANGED SO THE JOINTS OF THE SEWER PIPE WILL BE EQUIDISTANT FROM AND AS FAR AWAY FROM THE WATERMAIN JOINTS AS POSSIBLE. WHERE THE WATERMAIN CROSSES UNDER A SEWER, ADEQUATE STRUCTURAL SUPPORT SHALL BE PROVIDED FOR THE SEWER TO PREVENT DAMAGE TO THE WATERMAIN.
- E. WHEN IT IS IMPOSSIBLE TO OBTAIN THE PROPER HORIZONTAL AND VERTICAL SEPARATION AS STIPULATED ABOVE, THE SEWER SHALL BE EITHER ENCASED IN CONCRETE OR CONSTRUCTED OF PIPE MATERIAL EQUAL TO THE WATERMAIN AND PRESSURE TESTED AT 150 PSI TO ASSURE WATER TIGHTNESS.
- F. TRENCH DETAILS ARE ONLY SHOWN FOR PURPOSES OF MATERIALS PLACEMENT AND MAXIMUM PAY LIMITS.
- G. AN OSHA APPROVED MOVABLE PROTECTIVE TRENCH SHIELD SHALL BE USED IN ALL UNSHEETED TRENCH AREAS.

**MATERIALS**

SELECT MATERIAL BACKFILL (NYS DOT LATEST EDITION)

- ② NO.2 RUN OF CRUSHER STONE OR NO.2 RUN OF CRUSHER GRAVEL WITH A GRADATION CONFORMING WITH NYSDOT SECTION 304-2.02 TYPE 4 AND NYSDOT SECTION 703-02. (COMPACTED IN 6" LIFTS TO 90% DENSITY)

NOTE: SLAG SHALL NOT BE ALLOWED FOR MATERIALS ②

<b>ERIE COUNTY DEPT. OF ENVIRONMENT &amp; PLANNING DIVISION OF SEWERAGE MANAGEMENT</b>	<b>Revisions</b>		<b>STD.DETAIL</b>  <b>5</b>
	2/7/94	ADDED 6" TOPSOIL(MIN.) & NOTE F&G	
	01/03/01	REVISED NOTE A	
	12/01	Revised Note "A"	
	File: d-05	Date: 3/1/91	

# TYPICAL CONCRETE ENCASEMENT DETAIL

(JANUARY 2012)

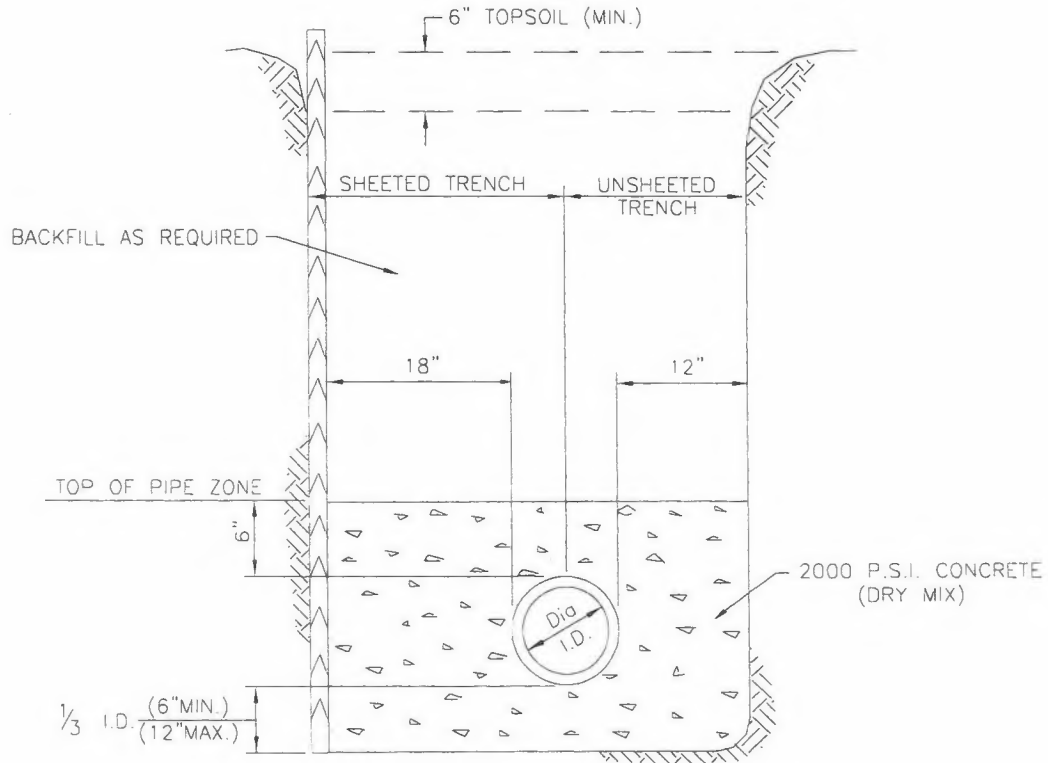

TYPICAL CONCRETE ENCASEMENT NOTES:

1. USE AS REQUIRED BY TEN STATE STANDARDS, OR AS ORDERED BY ENGINEER.
2. REQUIRED WHEN SEWER HAS LESS THAN 4 FEET OF COVER IN PAVED AREAS.

Revisions

8/23/91	ADDED 6" DIMENSION ABOVE SEWER
6/4/93	DELETED DEPTH REFERENCE NOTE
2/7/94	ADDED 6" TOPSOIL(MIN.) & NOTE
6/9/05	ADDED NOTES 1&2

STD.DETAIL

**ERIE COUNTY**  
**DEPT. OF ENVIRONMENT & PLANNING**  
**DIVISION OF SEWERAGE MANAGEMENT**

6

File: d-06

Date: 3/1/91

# CONCRETE CRADLE DETAIL

(JANUARY 2012)

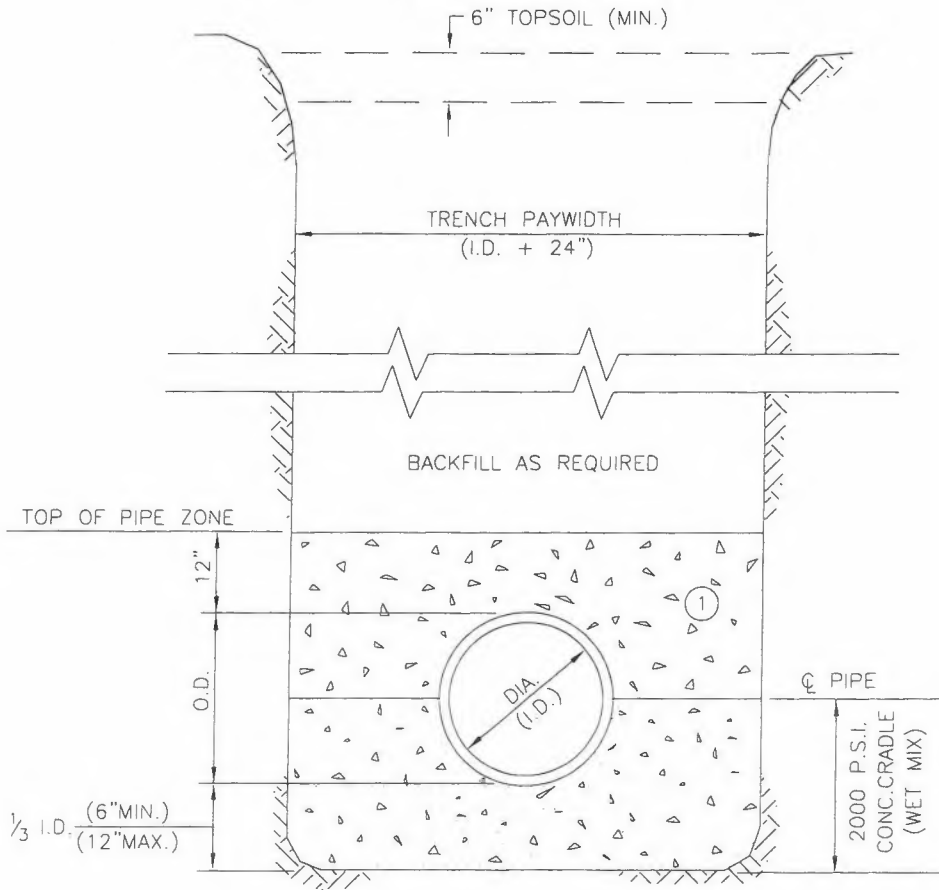

**NOTE:**

- A. TRENCH DETAILS ARE ONLY SHOWN FOR PURPOSES OF MATERIAL PLACEMENT AND MAXIMUM PAY LIMITS.
- B. AN OSHA APPROVED MOVABLE PROTECTIVE TRENCH SHIELD SHALL BE USED IN ALL UNSHEETED TRENCH AREAS.

**MATERIALS**

**PIPE BEDDING MATERIAL (NYS DOT LATEST EDITION)**

- ① NO.1 CRUSHED STONE WITH A GRADATION CONFORMING WITH NYS DOT SECTION 703-02. THE CRUSHED STONE SHALL BE WELL GRADED WITH NO PARTICLES LARGER THAN 1" AND HAVING A MAXIMUM GRADATION MEETING THE LIMITS DESCRIBED IN THE SPECIFICATIONS. THE BEDDING SHALL BE COMPACTED IN 6" LIFTS WITH EQUIPMENT ACCEPTABLE TO THE PIPE MANUFACTURER.

NOTE: SLAG SHALL NOT BE ALLOWED FOR MATERIALS ①

**ERIE COUNTY**  
**DEPT. OF ENVIRONMENT & PLANNING**  
**DIVISION OF SEWERAGE MANAGEMENT**

Rev. 1	ADDED 6" TOPSOIL & NOTE A & B	STD.DETAIL
2/7/94		
Rev. 2		
File:	d-07	Date: 3/1/91

7



# PAVEMENT AND DRIVEWAY REPLACEMENT DETAIL (JANUARY 2012)

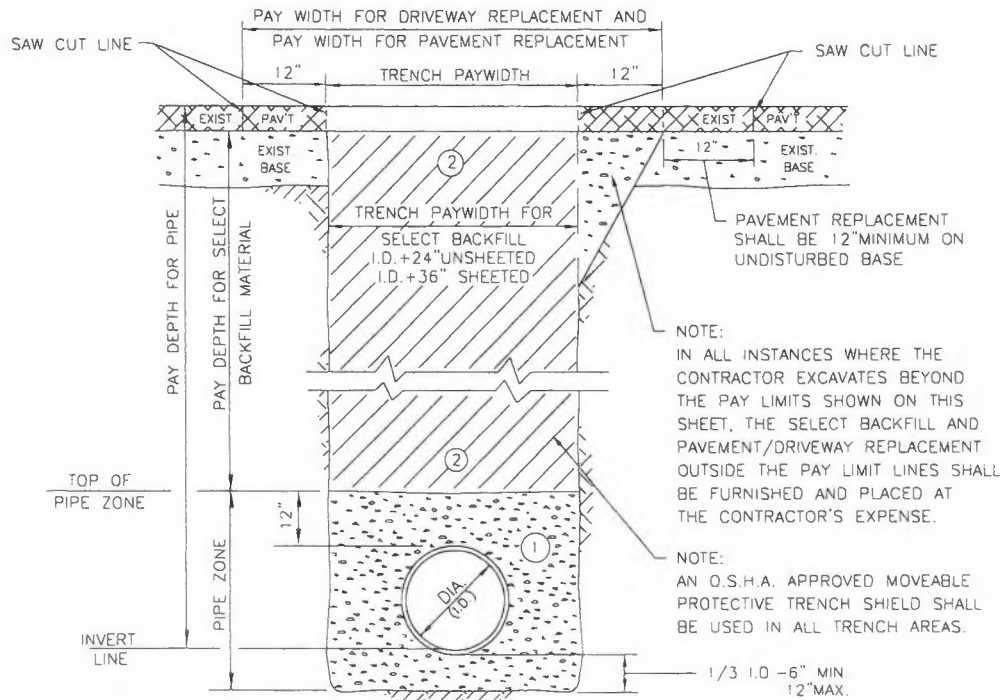

NOTE:  
IN ALL INSTANCES WHERE THE CONTRACTOR EXCAVATES BEYOND THE PAY LIMITS SHOWN ON THIS SHEET, THE SELECT BACKFILL AND PAVEMENT/DRIVEWAY REPLACEMENT OUTSIDE THE PAY LIMIT LINES SHALL BE FURNISHED AND PLACED AT THE CONTRACTOR'S EXPENSE.

NOTE:  
AN O.S.H.A. APPROVED MOVEABLE PROTECTIVE TRENCH SHIELD SHALL BE USED IN ALL TRENCH AREAS.

### BLACKTOP REPLACEMENT

ALL ROADS AND DRIVEWAYS SHALL BE RECONSTRUCTED WITH A MIN 3" COURSE OF BINDER AND A 1-1/2" TOP COURSE. APPLICABLE HIGHWAY PERMIT CONDITIONS SHALL GOVERN.

- TEMP. PAV'T.**
1. IF CONSTRUCTION IS PERFORMED BETWEEN OCTOBER 1 AND APRIL 1, THE CONTRACTOR IS REQUIRED TO PROVIDE 4" OF COLD PATCH FOR ALL PAVEMENT CUTS.
  2. ALL OPEN CUTS WITHIN 50' OF AN INTERSECTION SHALL BE TOPPED WITH 4" OF COLD PATCH REGARDLESS OF THE TIME OF YEAR
  3. ALL ROAD CUTS ON HEAVILY TRAVELED ROADWAYS WILL REQUIRE 4" OF COLD PATCH (GENERALLY STATE AND COUNTY HIGHWAYS)
  4. ALL TEMPORARY PAVEMENT PATCHES SHALL BE MAINTAINED BY THE CONTRACTOR.
- SAW CUTS**
1. PAVEMENT/DRIVEWAY CUTS BY THE CONTRACTOR WILL BE MADE WITH A SAW, PNEUMATIC SPADE OR OTHER ACCEPTED MEANS PRIOR TO EXCAVATION.
  2. FINAL PAVEMENT/DRIVEWAY RESTORATION: THE CONTRACTOR WILL BE RESPONSIBLE TO SAW CUT AN ADDITIONAL 12" ON EACH SIDE OF THE DISTURBED TRENCH AREA, SO AS TO PROVIDE A UNIFORM STRAIGHT EDGE. THE CUT EDGE WILL THEN BE COATED WITH A BITUMINOUS SEAL COAT AND REPLACED IN THE MANNER DESCRIBED ABOVE.

### CONCRETE DRIVEWAY REPLACEMENT

1. THE CONTRACTOR SHALL REMOVE ALL CONCRETE DAMAGE BY HIS OPERATION. THE EXISTING CONCRETE AT THE DAMAGED EDGE SHALL BE SAW CUT TO PROVIDE A STRAIGHT EDGE JOINT BETWEEN OLD AND NEW, WITH EXPANSION JOINT MATERIAL INSTALLED AT THE TRANSITION. THE CONTRACTOR SHALL BE REQUIRED TO RECONSTRUCT THE DRIVEWAY WITH 4000 PSI CONCRETE MATCHING THE DEPTH AND WIDTH OF THE EXISTING DRIVEWAY.

### MATERIALS

#### PIPE BEDDING MATERIAL (NYS DOT LATEST EDITION)

- ① NO.1 CRUSHED STONE WITH A GRADATION CONFORMING WITH NYS DOT SECTION 703-02. THE CRUSHED STONE SHALL BE WELL GRADED WITH NO PARTICLES LARGER THAN 1" AND HAVING A MAXIMUM GRADATION MEETING THE LIMITS DESCRIBED IN THE SPECIFICATIONS. THE BEDDING SHALL BE COMPACTED IN 6" LIFTS WITH EQUIPMENT ACCEPTABLE TO THE PIPE MANUFACTURER.

#### SELECT MATERIAL BACKFILL (NYS DOT LATEST EDITION)

- ② NO.2 RUN OF CRUSHER STONE OR NO.2 RUN OF CRUSHER GRAVEL WITH A GRADATION CONFORMING WITH NYS DOT SECTION 304-2.02 TYPE 4 AND NYS DOT SECTION 703-02. (COMPACTED IN 6" LIFTS TO 90% DENSITY) **NOTE:** SLAG SHALL NOT BE ALLOWED FOR MATERIALS ① AND ②

**ERIE COUNTY**  
**DEPT. OF ENVIRONMENT & PLANNING**  
**DIVISION OF SEWERAGE MANAGEMENT**

Rev. 2	REVISED PAY LIMITS FOR TRENCH
Rev. 3 01/03/01	REVISED TITLE AND PAY WIDTH NOTE
Rev. 4 12/01	Added conc. driveway replace. note
File:	d-08
Date:	3/1/91

STD.DETAIL

8

# PIPE CROSSING SUPPORT DETAIL

(NOVEMBER 2023)

EXIST. PIPE CROSSING (SEE WATER MAIN CROSSING DETAIL FOR CONCRETE ENCASEMENT.)

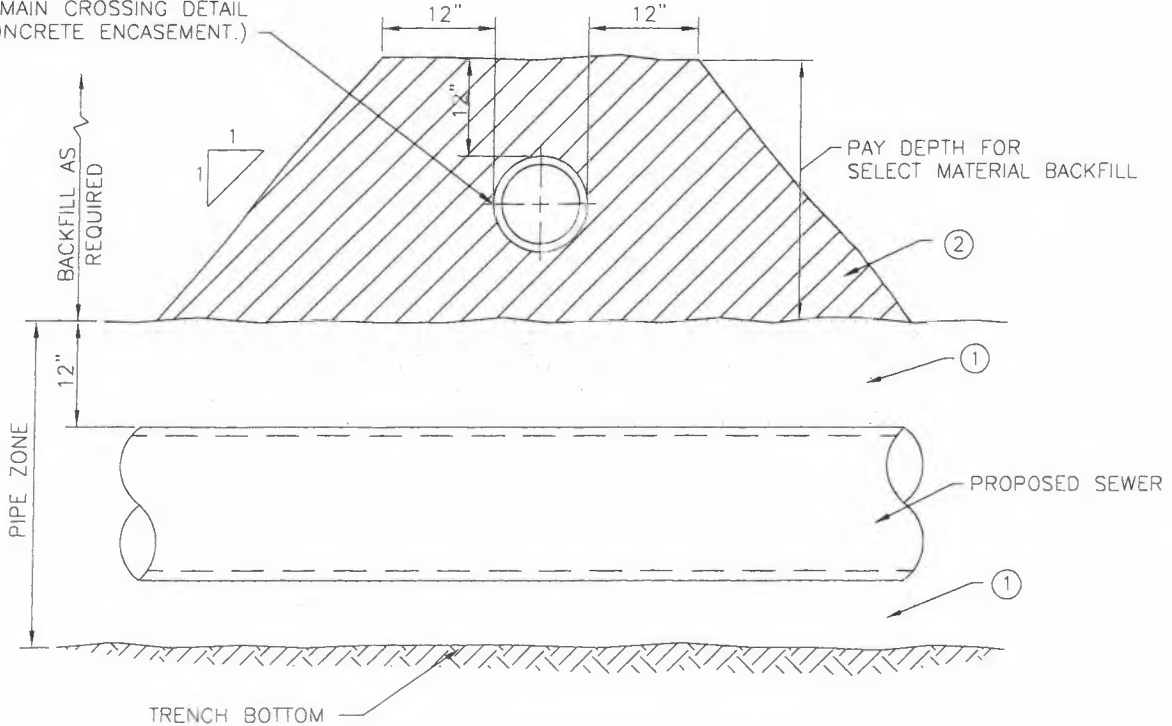

## MATERIALS

### PIPE BEDDING MATERIAL (NYS DOT LATEST EDITION)

- ① NO.1 CRUSHED STONE WITH A GRADATION CONFORMING WITH NYSDOT SECTION 703-02. THE CRUSHED STONE SHALL BE WELL GRADED WITH NO PARTICLES LARGER THAN 1" AND HAVING A MAXIMUM GRADATION MEETING THE LIMITS DESCRIBED IN THE SPECIFICATIONS. THE BEDDING SHALL BE COMPACTED IN 6" LIFTS WITH EQUIPMENT ACCEPTABLE TO THE PIPE MANUFACTURER.

### SELECT MATERIAL BACKFILL (NYS DOT LATEST EDITION)

- ② NO.2 RUN OF CRUSHER STONE OR NO.2 RUN OF CRUSHER GRAVEL WITH A GRADATION CONFORMING WITH NYSDOT STANDARD SPECIFICATION 304.12 - TYPE 2 SUBBASE (COMPACTED IN 6" LIFTS TO 95% DENSITY)

NOTE: SLAG SHALL NOT BE ALLOWED FOR MATERIALS ① AND ②

V:\DSM\Engineering\CAD\Details\November 2023\D-09.dwg, Model, 2023/11/20 11:19 am

ERIE COUNTY  
DEPT. OF ENVIRONMENT & PLANNING  
DIVISION OF SEWERAGE MANAGEMENT

Rev. 1	UPDATED MATERIALS TO NYSDOT LATEST EDITION
12/01	
Rev. 2	UPDATED MATERIALS TO NYSDOT LATEST EDITION
11/23	
File:	D-09
Date:	3/1/91

STD.DETAIL

9

**MONOLITHIC PRECAST BASE MANHOLES**  
**4'-0" DIA. BASE FOR 15"Ø SEWERS OR LESS**  
 (JANUARY 2012)

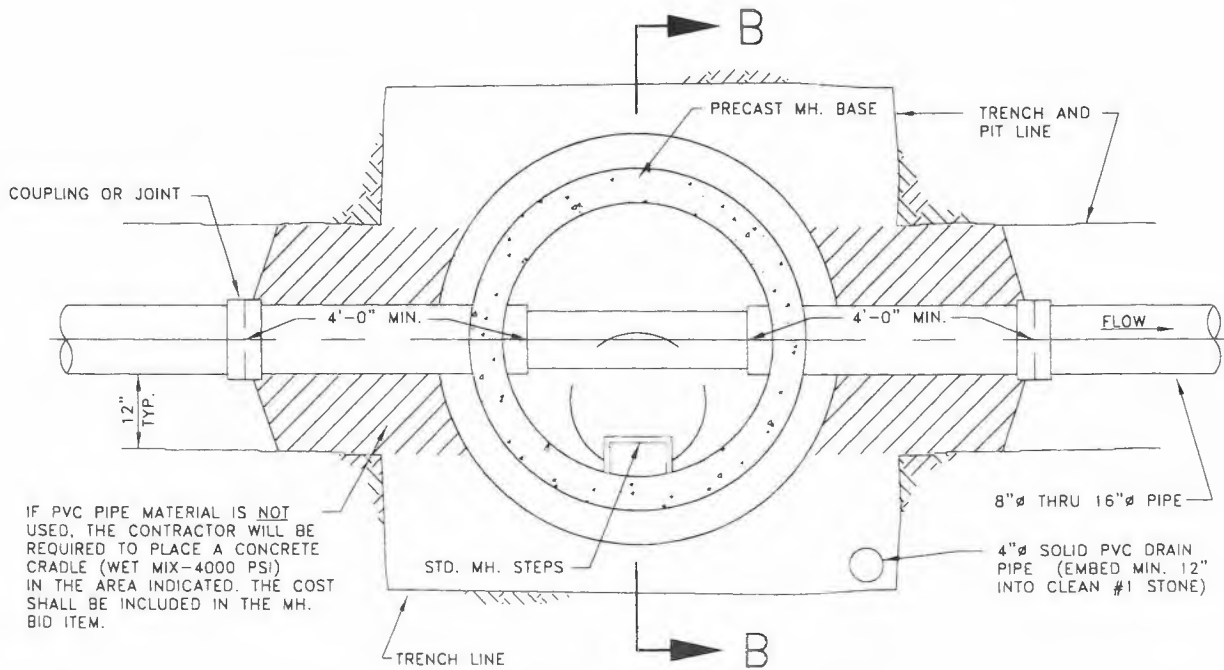

PLAN

ERIE COUNTY  
 DEPT. OF ENVIRONMENT & PLANNING  
 DIVISION OF SEWERAGE MANAGEMENT

Rev. 1 REVISED 4" PVC TO SOLID PIPE  
 12/01 IN #1 STONE BED

Rev. 2

File: d-10

Date: 3/1/91

STD.DETAIL

10

# MONOLITHIC PRECAST BASE MANHOLES 4'-0" DIA. BASE FOR 15"Ø SEWERS OR LESS (SECTION B-B) (JANUARY 2012)

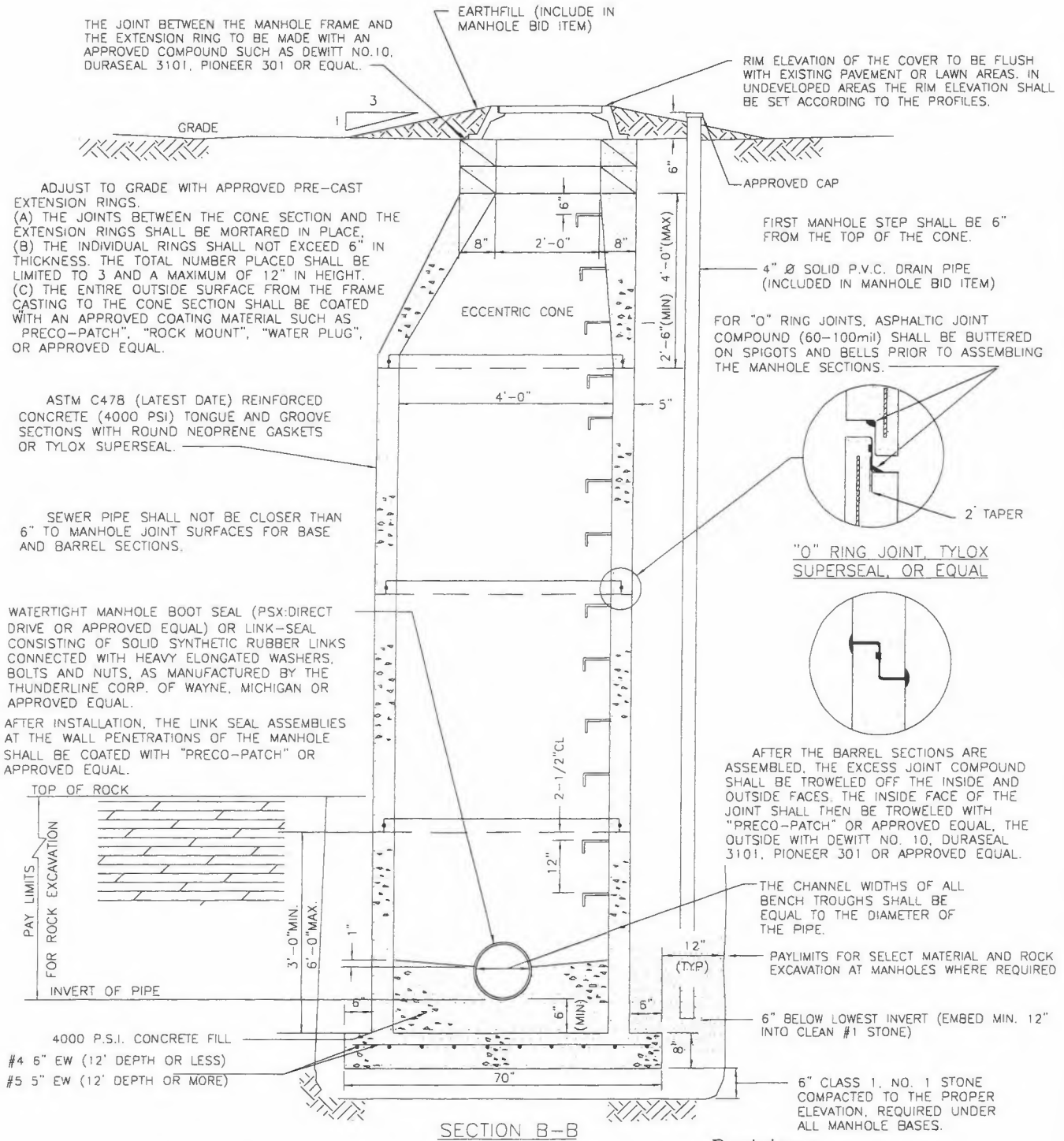

### Revisions

07/15/99	ADD ROCK EXCAVATION PAYLIMITS
11/23/99	ADD 4"x4"x6" MARKER AND NOTES
12/01	REVISED 4" P.V.C. TO SOLID PIPE
03/04/03	ADDED WATER TIGHT BOOT SEAL NOTE
06/22/05	ADDED TYLOX SUPERSEAL NOTES REMOVED WOOD POST AND NOTES
02/27/07	CHANGED THE NUMBER OF EXTENSION RINGS FROM 2 TO 3
File:	d-11
Date:	3/1/91

STD.DETAIL

11

**ERIE COUNTY  
DEPT. OF ENVIRONMENT & PLANNING  
DIVISION OF SEWERAGE MANAGEMENT**

# MONOLITHIC PRECAST BASE MANHOLES

## PIPE SIZES 18"Ø THRU 36"Ø

(JANUARY 2012)

THE JOINT BETWEEN THE MANHOLE FRAME AND THE EXTENSION RING TO BE MADE WITH AN APPROVED COMPOUND SUCH AS DEWITT NO.10, DURASEAL 3101, PIONEER 301 OR EQUAL.

RIM ELEVATION TO BE FLUSH WITH EXISTING PAVEMENT OR LAWN AREAS. IN UNDEVELOPED AREAS SET THE RIM ELEVATION ACCORDING TO THE PROFILES.

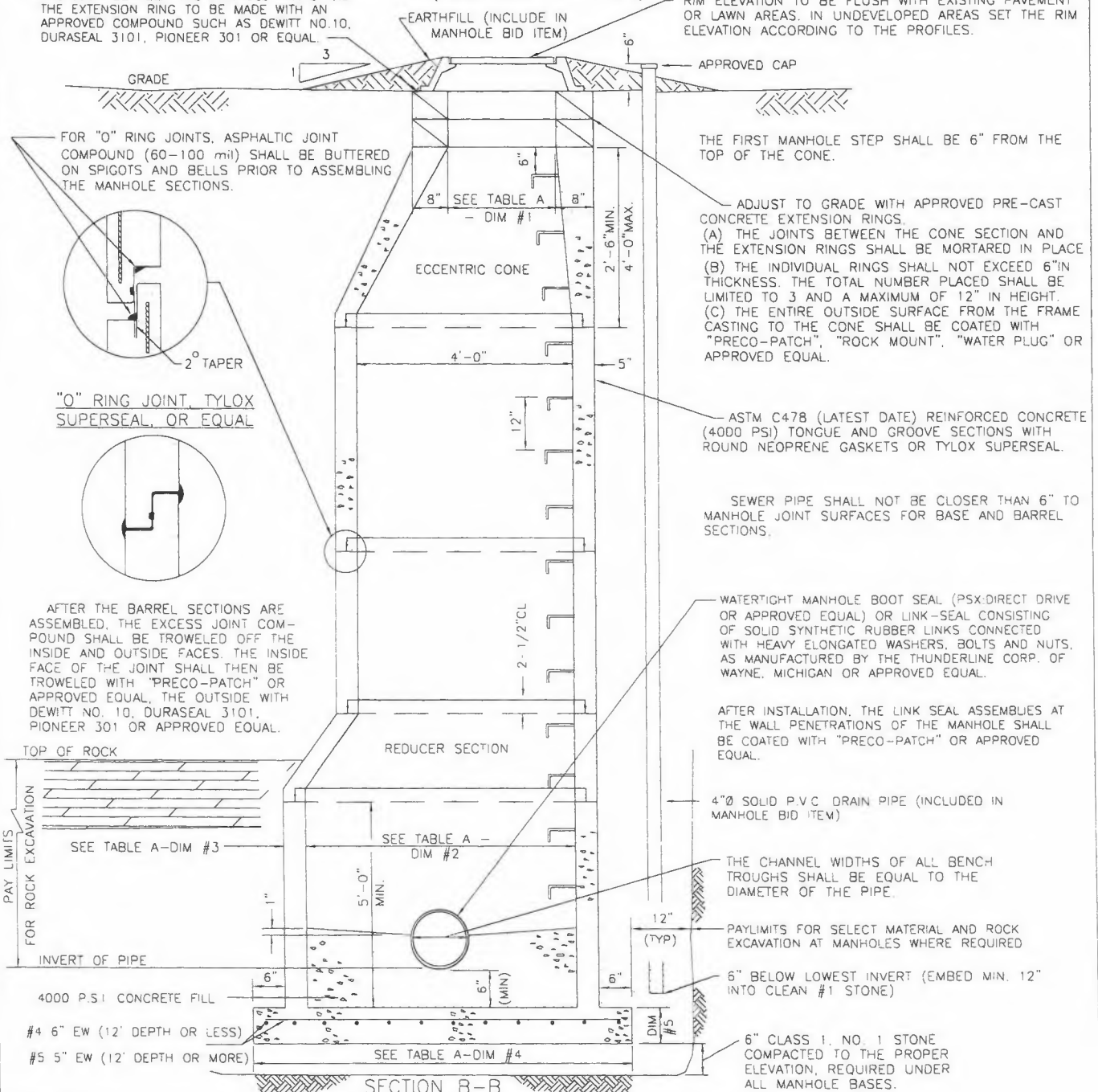

PAY LIMITS FOR ROCK EXCAVATION

4000 P.S.I CONCRETE FILL  
 #4 6" EW (12' DEPTH OR LESS)  
 #5 5" EW (12' DEPTH OR MORE)

PIPE SIZE	DIMENSION #1	DIMENSION #2	DIMENSION #3	DIMENSION #4	DIMENSION #5
18"	24"	5'-0"	6"	84"	8"
21" - 27"	36"	6'-0"	7"	98"	8"
30" - 36"	36"	8'-0"	9"	126"	14"

### REVISIONS

12/9/96	CHANGED JOINT COMPOUND TO ASPHALTIC (60-100 mil)
07/15/99	ADD ROCK ELEVATIONS
12/01	REVISED 4" P.V.C. TO SOLID PIPE
03/04/03	ADDED WATER TIGHT BOOT SEAL NOTE
06/22/05	ADDED TYLOX SUPERSEAL NOTES
02/27/07	CHANGED THE NUMBER OF EXTENSION RINGS FROM 2 TO 3

ERIE COUNTY  
 DEPT. OF ENVIRONMENT & PLANNING  
 DIVISION OF SEWERAGE MANAGEMENT

STD.DETAIL

12

File: d-12 Date: 3/1/91

# STANDARD FRAME AND COVER

(DECEMBER 2013)

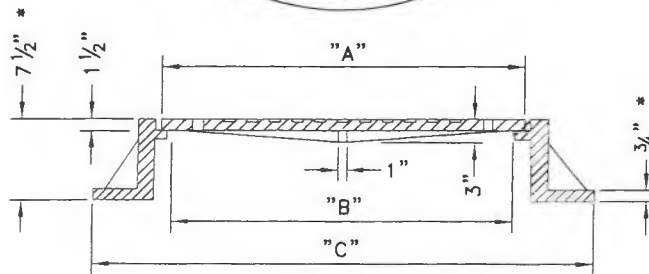
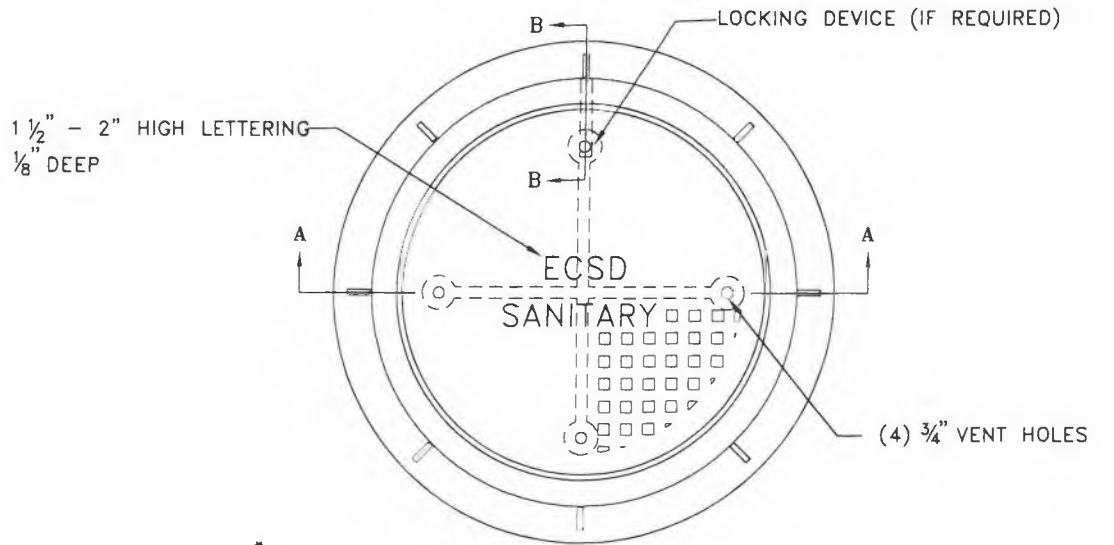

SECTION A-A

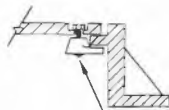

B-B  
ROTATE CAM TO LOCK COVER (OR EQUAL)

LOCKING DEVICE IF REQUIRED

TABLE				
PIPE SIZE	DIMENSION "A"	DIMENSION "B"	DIMENSION "C"	WEIGHT OF COVER
8" THRU 18"	24"	22 1/4"	35"(MAX.)	150 LB. ± 5%
OVER 18"	32"	30"	46"(MAX.)	200 LB. ± 5%

### STANDARD FRAME AND COVER NOTES

1. MATERIAL: ASTM A48 CLASS 30B CAST IRON CONFORMING TO AASHTO DESIGNATION M105-06.
2. UNIT MUST WITHSTAND H-20 WHEEL LOADING, AND CONFORM TO AASHTO DESIGNATION M306-10.
3. ALL DIMENSIONS ARE TO BE CONSIDERED MINIMUM WITH THE EXCEPTION OF THE COVER, WHICH MUST CONFORM EXACTLY TO MAINTAIN INTERCHANGEABILITY WITHIN THE COUNTY.
4. COATING NOT REQUIRED.
5. FRAMES AND COVERS SHALL HAVE MACHINED BEARING SURFACES.
6. LOCKING DEVICE MUST BE SITUATED TO ALLOW EASY REMOVAL OF COVER.
7. NO LETTERING OTHER THAN ECSD SANITARY WILL BE ALLOWED ON THE EXPOSED SURFACE OF THE COVER.
8. \* 1/2" FLANGE THICKNESS AND 7" HEIGHT ACCEPTABLE IF CLASS 35 CAST IRON MATERIAL PROVIDED.

**ERIE COUNTY**  
DEPT. OF ENVIRONMENT & PLANNING  
DIVISION OF SEWERAGE MANAGEMENT

**Rev. 1** 4/9/96 REV'D PIPE SIZE TO OVER 18"  
**Rev. 2** 12/9/96 REV'D <18" DIMENSIONS  
**Rev. 3** 5/5/03 REV'D FRAME & LOCKS  
**Rev. 4** 6/28/06 ADDED WEIGHTS TO TABLE  
**Rev. 5** 12/26/13 REVISED NOTES 1 & 2 TO REFERENCE AASHTO STANDARDS AND ADDED NOTE 8

STD.DETAIL

13

File: d-13

Date: 3/1/91



# STANDARD MANHOLE STEP (JANUARY 2012)

SECTION OF STEP TO BE EMBEDDED IN WALL SHALL BE PAINTED WITH APPROVED BITUMASTIC PAINT.

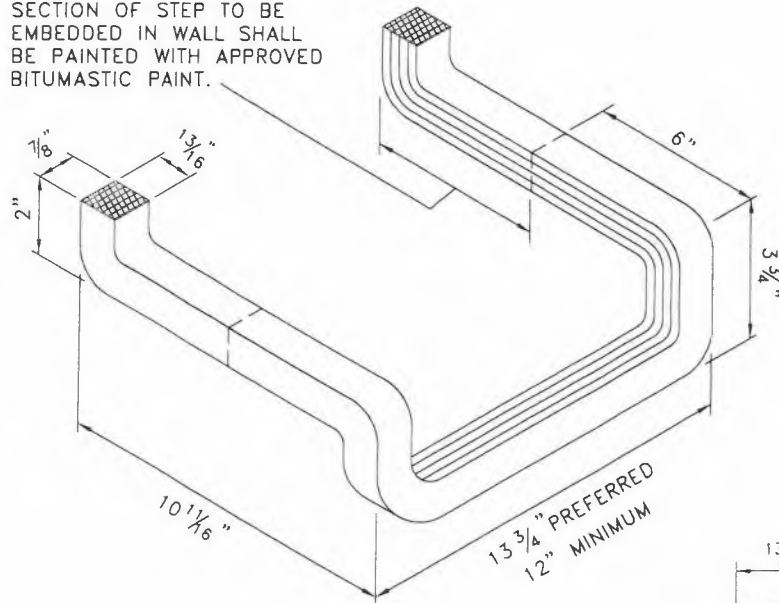

(DROP FRONT TYPE)

NOTES:

1. MANHOLE STEPS SHALL BE OF FORGED ALUMINUM ALLOY.
2. AN ACCEPTABLE ALTERNATE IS THE STEEL REINFORCED COPOLYMER POLYPROPYLENE MANHOLE STEP.
3. THE STEPS SHALL BE EMBEDDED IN THE WALLS OF THE CONCRETE MANHOLE BARREL WHILE THE MANHOLE IS BEING CAST OR SECURELY GROUTED IN PLACE AFTER CASTING.

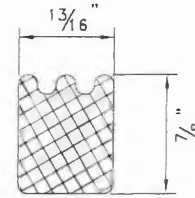

TYPICAL SECTION

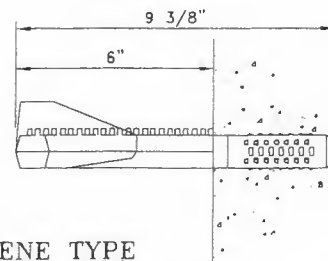
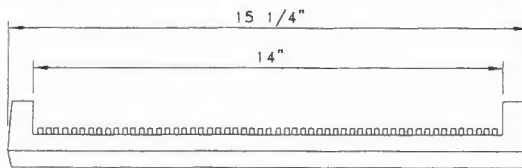
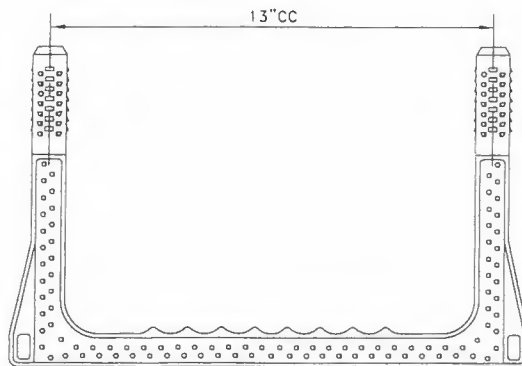

REINFORCED COPOLYMER POLYPROPELENE TYPE

ERIE COUNTY  
DEPT. OF ENVIRONMENT & PLANNING  
DIVISION OF SEWERAGE MANAGEMENT

Rev. 1 12/9/96 ADDED REINFORCED COPOLYMER TYPE STEP

Rev. 2

File: d-17 Date: 3/1/91

STD.DETAIL

17



# INSIDE DROP PIPE (JANUARY 2012)

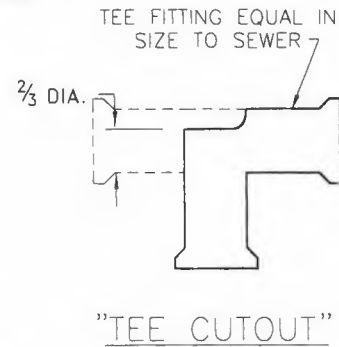
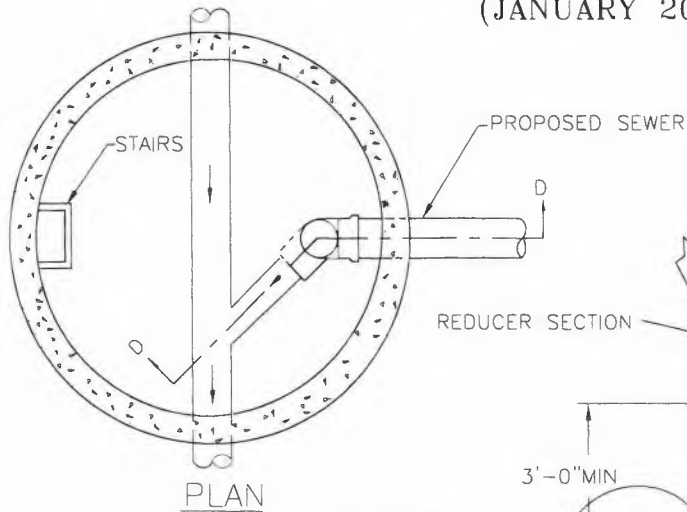

DROP ASSEMBLY CAN ALSO BE A DURAN, INC. INSIDE DROP BOWL, OR APPROVED EQUAL

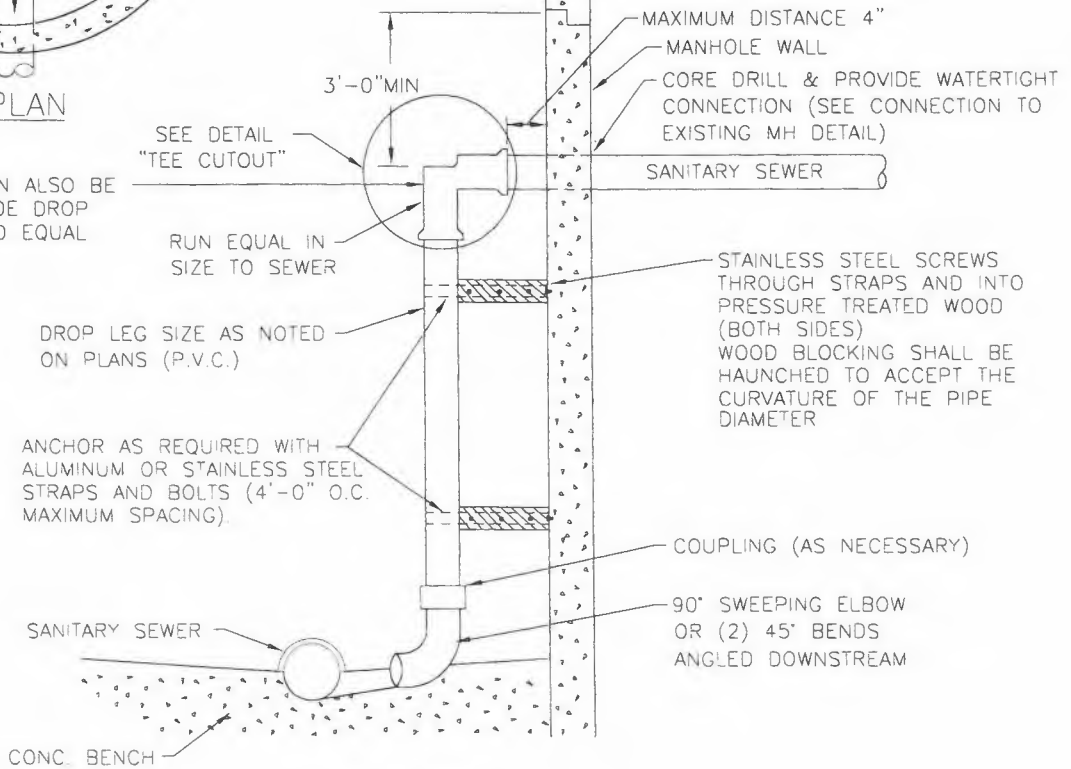

**NOTES:**

1. A DROP PIPE SHALL BE PROVIDED FOR A SEWER ENTERING A MANHOLE AT AN ELEVATION OF 24 INCHES OR MORE ABOVE THE MANHOLE INVERT. ONLY INSIDE DROP ASSEMBLIES WILL BE ALLOWED.
2. INSIDE DROP LEG SHALL BE INSTALLED ON MANHOLE WALL LOCATED AS SHOWN OR AS APPROVED BY ECDSM
3. ON NEW CONSTRUCTION INSIDE DROP ASSEMBLIES SHALL BE INSTALLED IN MANHOLES NOT LESS THAN 5'-0" IN DIAMETER.

PIPE SIZE	MANHOLE I. D
18"	5'-0"
21" - 27"	6'-0"
30" - 36"	8'-0"

**REVISIONS**

4/24/93	CHANGED TEE CUTOUT
6/1/93	BENCH CONFIGURATION & REDUCER SECTION CLEARANCE
2/7/94	CHANGED MAX. DIST. FROM MH TO TEE ADDED STAINLESS STEEL BOLTS/SCREWS
7/13/99	CHANGED NOTE NO.2, ADD SIZE CHART
12/22/00	REVISED TEE CUTOUT & SPACERS NOTE
6/23/05	ADDED DURAN, INC. DROP BOWL NOTE
File: D-18 Date: 3/1/91	

**ERIE COUNTY**  
DEPT. OF ENVIRONMENT & PLANNING  
DIVISION OF SEWERAGE MANAGEMENT

STD.DETAIL

18

# MANHOLE VENT DETAIL

(JANUARY 2012)

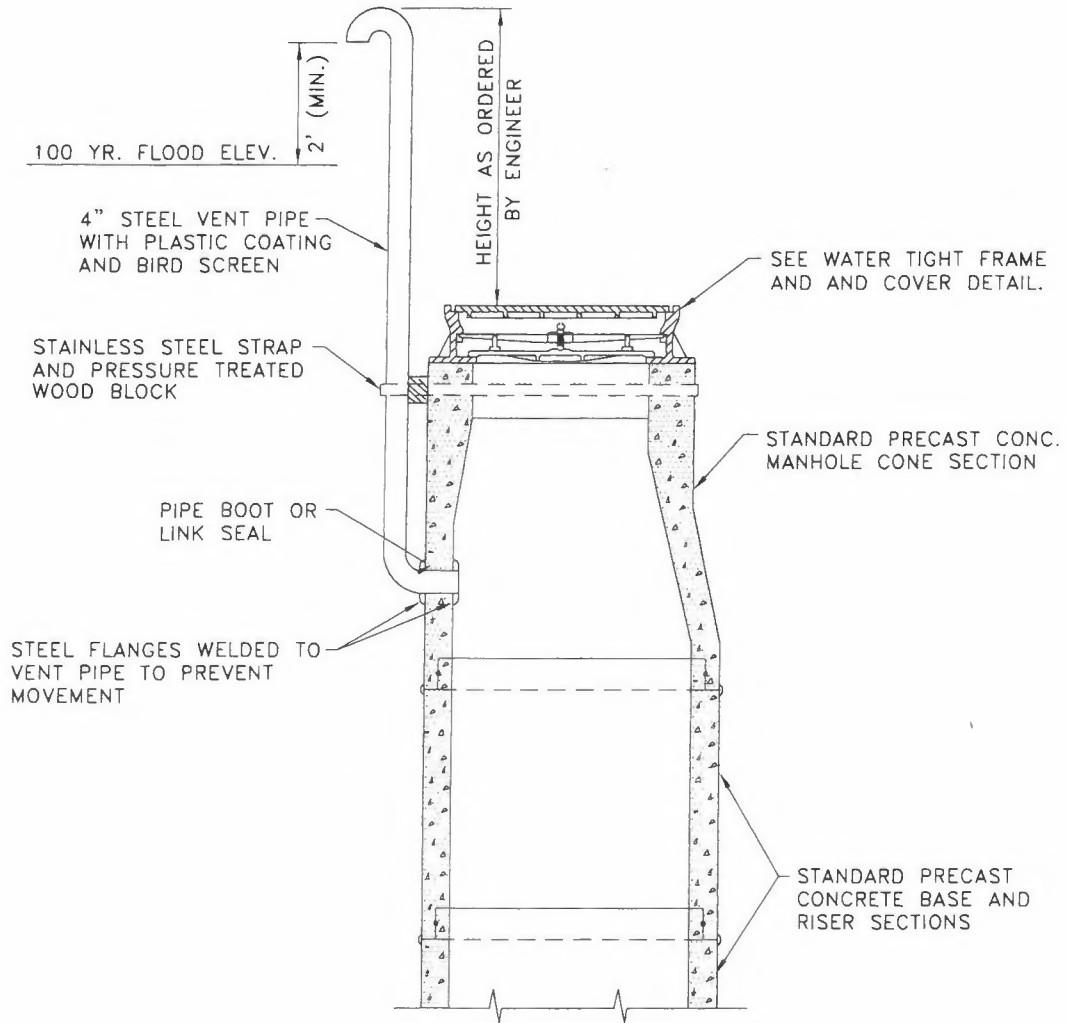

ERIE COUNTY  
DEPT. OF ENVIRONMENT & PLANNING  
DIVISION OF SEWERAGE MANAGEMENT

Rev. 1	ADDED BIRD SCREEN & PRESSURE TREATED WOOD TO VENT PIPE, ADDED 2' (MIN) DIM. ABOVE 100yr FLOOD
2/7/94	
Rev. 2	ADDED PIPE BOOT OR LINK SEAL NOTE TO VENT PIPE
12/01	
File:	d-19
Date:	3/1/91

STD.DETAIL

19

# TREE REMOVAL AND REPLACEMENT POLICY

(JANUARY 2012)

## GENERAL CONDITIONS

1. REMOVE AS INDICATED WITH AN ("R") ALL TREES UNDER 8" IN DIAMETER AND OFFER PROPERTY OWNER A REPLACEMENT TREE OF THE SAME SPECIES ON A ONE FOR ONE BASIS.
2. REMOVE AS INDICATED WITH AN ("R") ALL TREES 8" IN DIAMETER AND OVER, THEN OFFER THE PROPERTY OWNER REPLACEMENT TREES OF THE SAME SPECIES ON A TWO FOR ONE BASIS.
3. TREES MARKED "R1" SHALL BE REPLACED ON A ONE FOR ONE BASIS REGARDLESS OF SIZE. TREES MARKED "R2" SHALL NOT BE REPLACED AT ALL. ALL "R2" AREAS SHALL BE GRADED, TOPSOILED AND HYDROSEEDDED UNLESS OTHERWISE NOTED.
4. THE CONTRACTOR SHALL CONSIDER IN HIS BID ALL COSTS ASSOCIATED WITH THE REMOVAL OF EXISTING TREES AND PROVIDING AND PLANTING THE REPLACEMENT TREES (MIN 3" DIA). NO ADDITIONAL COMPENSATION WILL BE PROVIDED.
5. THE CONTRACTOR SHALL, FOR THOSE TREES SO MARKED ("T") TUNNEL, BID THE ITEM TO TUNNEL OR BORE AND JACK THE SEWER PAST THE TREE.
6. IF THE TREE IS OVER 15" IN DIAMETER AND THE TRENCH IS OVER 8' FROM THE TRUNK BUT STILL WITHIN THE DRIP LINE, THE TREES CROWN MUST BE PRUNED BACK TO COMPENSATE FOR LOSS OF ROOT STRUCTURE.
7. IF THE PROPERTY OWNER AGREES IN WRITING, HEALTHY TREES MAY BE REMOVED FROM THE EASEMENT REGARDLESS OF VARIETY OR SIZE.
8. THE CONTRACTOR SHALL RETAIN THE SERVICES OF A QUALIFIED NURSERY MAN DURING THE LIFE OF THE CONTRACT

## SPECIAL CONDITIONS

1. FOR AREAS WITHIN THE HIGHWAY RIGHT-OF-WAY THE CONTRACTOR SHALL REMOVE ALL TREES INDICATED WITH AN "R" AND PROVIDE REPLACEMENT TREES AS DESCRIBED IN THE "GENERAL CONDITIONS". THE PLANTING OF THE REPLACEMENT TREES SHALL BE OUTSIDE THE RIGHT-OF-WAY LINE ONLY AFTER THE CONTRACTOR RECEIVES A RELEASE FROM THE PROPERTY OWNER ALLOWING THE PLANTING ON THEIR PROPERTY. THE NEW REPLACEMENT TREE(S) SHALL BE PLANTED IN AN AREA NEAR THE HIGHWAY RIGHT-OF-WAY AT A MINIMUM DISTANCE OF 8'-0" AWAY FROM THE INSTALLED PIPELINE. ALL ADDITIONAL SITE RESTORATION CAUSED BY THE NEW TREE PLANTING SHALL BE THE RESPONSIBILITY OF THE CONTRACTOR AND SHALL BE COMPLETED AT NO ADDITIONAL COST TO THE COUNTY.

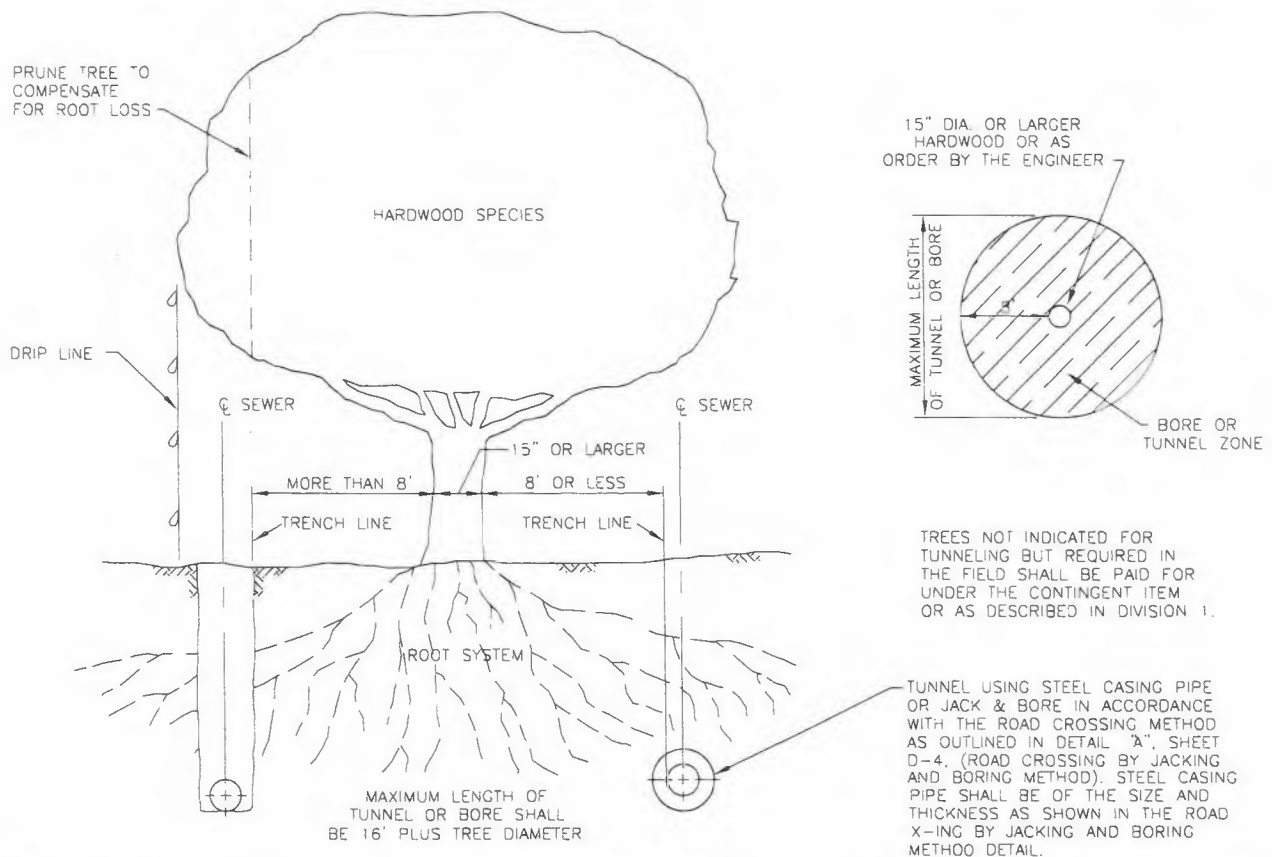

7/12/99	REVISED NOTES FOR 8" TO OVER	S
Rev. 2	CONDITIONS TO GENERAL & SPECIAL	
File: d-20	c: 3/1/91	

# TYPICAL HOUSE SERVICE DETAIL (JANUARY 2012)

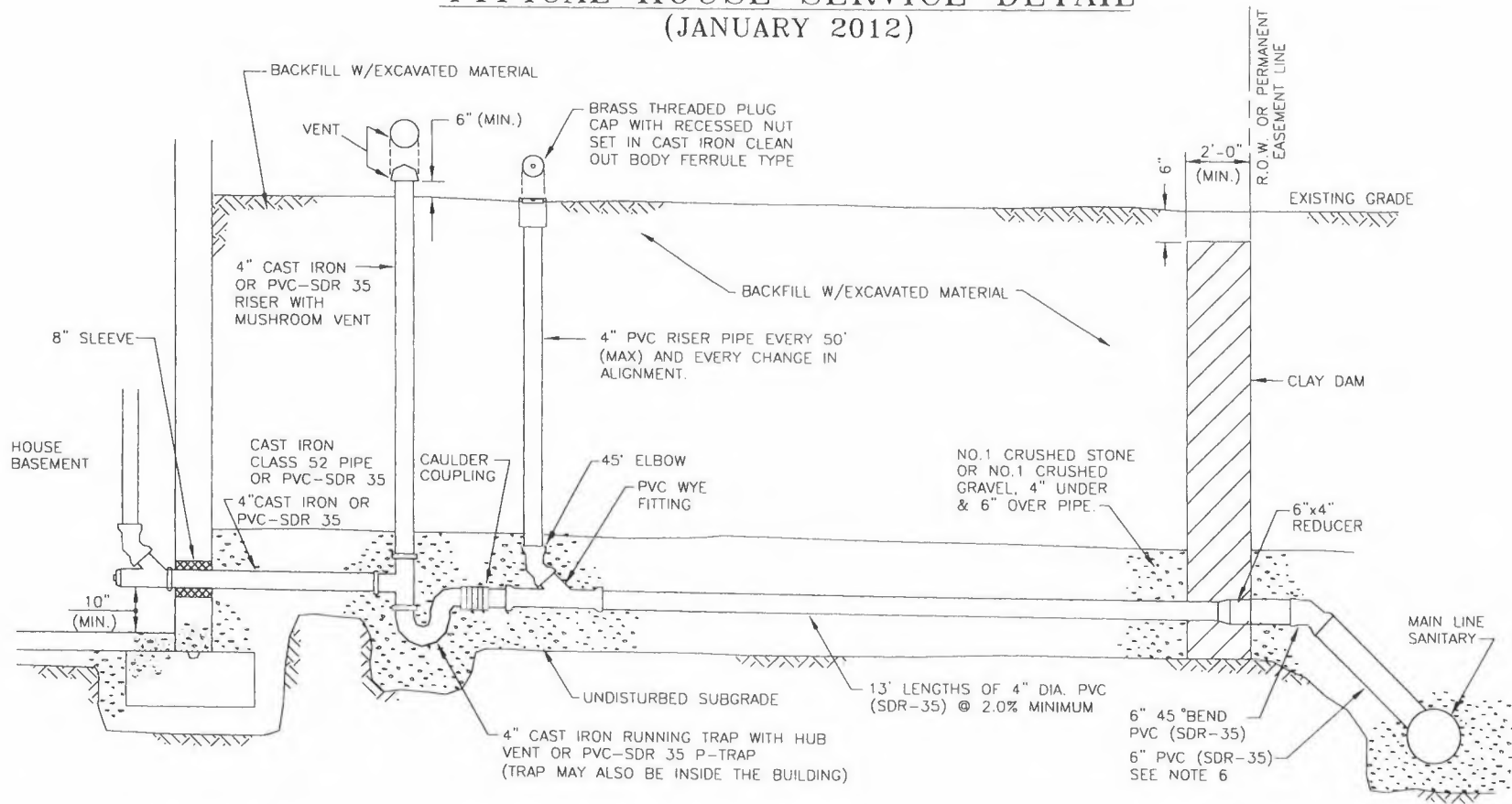

**NOTES:**

1. NO INSPECTION WILL BE PROVIDED WITHOUT A PERMIT. INSPECTIONS REQUIRE 48 HR. ADVANCE NOTICE FOR SCHEDULING.
2. ALL WORK MUST BE INSPECTED BY A COUNTY INSPECTOR.
3. PVC PIPE MATERIAL SHALL BE MANUFACTURED IN ACCORDANCE WITH THE REQUIREMENTS OF THE LATEST ASTM SPECIFICATION D-3033/D-3034. CAST IRON PIPE MATERIAL SHALL BE EXTRA HEAVY CAST IRON MEETING THE REQUIREMENTS OF ASTM A74-42.
4. A MANUAL VALVE SHALL BE INSTALLED ON BASEMENT LAUNDRY DRAIN LINE.
5. VENTS AND CLEAN OUTS MUST BE INSTALLED IN LAWN AREAS, NOT IN SIDEWALK OR DRIVEWAY AREAS, PREFERABLY BETWEEN THE CURB OR EDGE OF PAVEMENT, AND THE SIDEWALK.
6. SELECT BACKFILL REQUIRED UNDER PAVED AREAS.
7. CONCRETE ENCASUREMENT IF COVER DEPTH IS LESS THAN 4'-0" UNDER PAVED AREAS.
8. FOR NEW CONSTRUCTION, AN 8x6 WYE WITH 6" PVC TO 6" 45° BEND, THEN 6" x 4" REDUCER IS USED.
9. A 6" CLEAN OUT IS REQUIRED AT R.O.W. WHENEVER THE MAIN SEWER IS UNDER THE PAVEMENT LIMITS OR AT FAR SIDE OF PAVEMENT.
10. ANY EXCAVATION TO BE LEFT OPEN OVERNIGHT SHALL BE COMPLETELY ENCLOSED IN FENCING, OR WHERE NECESSARY, COVERED WITH STEEL PLATES.
11. DOWN SPOUTS, SUMP PUMPS, AND FOOTING DRAINS ARE NOT PERMITTED TO BE CONNECTED TO THE HOUSE LATERAL.
12. FOR NEW STRUCTURES, NO CONNECTION SHALL BE MADE UNTIL BUILDING ROOF IS ERECTED AND BASEMENT FLOOR IS POURED.

**ERIE COUNTY  
DEPT. OF ENVIRONMENT & PLANNING  
DIVISION OF SEWERAGE MANAGEMENT**

Rev. 6/05	ADDED NOTE 20 & CLASS 52 TYPE CI PIPE
Rev. 1/07	REMOVED OLD NOTES 1,3,8,10,12,13 AND 20 REVISED TO 6" PVC-DET6, 48 HR ADV NOTICE
Rev. 11/08	ADDED PVC TRAP AND SLEEVE
Rev. 01/12	REVISED 4" CAST IRON TRAP
File:	d-21
Date:	3/1/91

STD. DETAIL

21

# TAPPING LINED PIPES

## AUGUST 2019

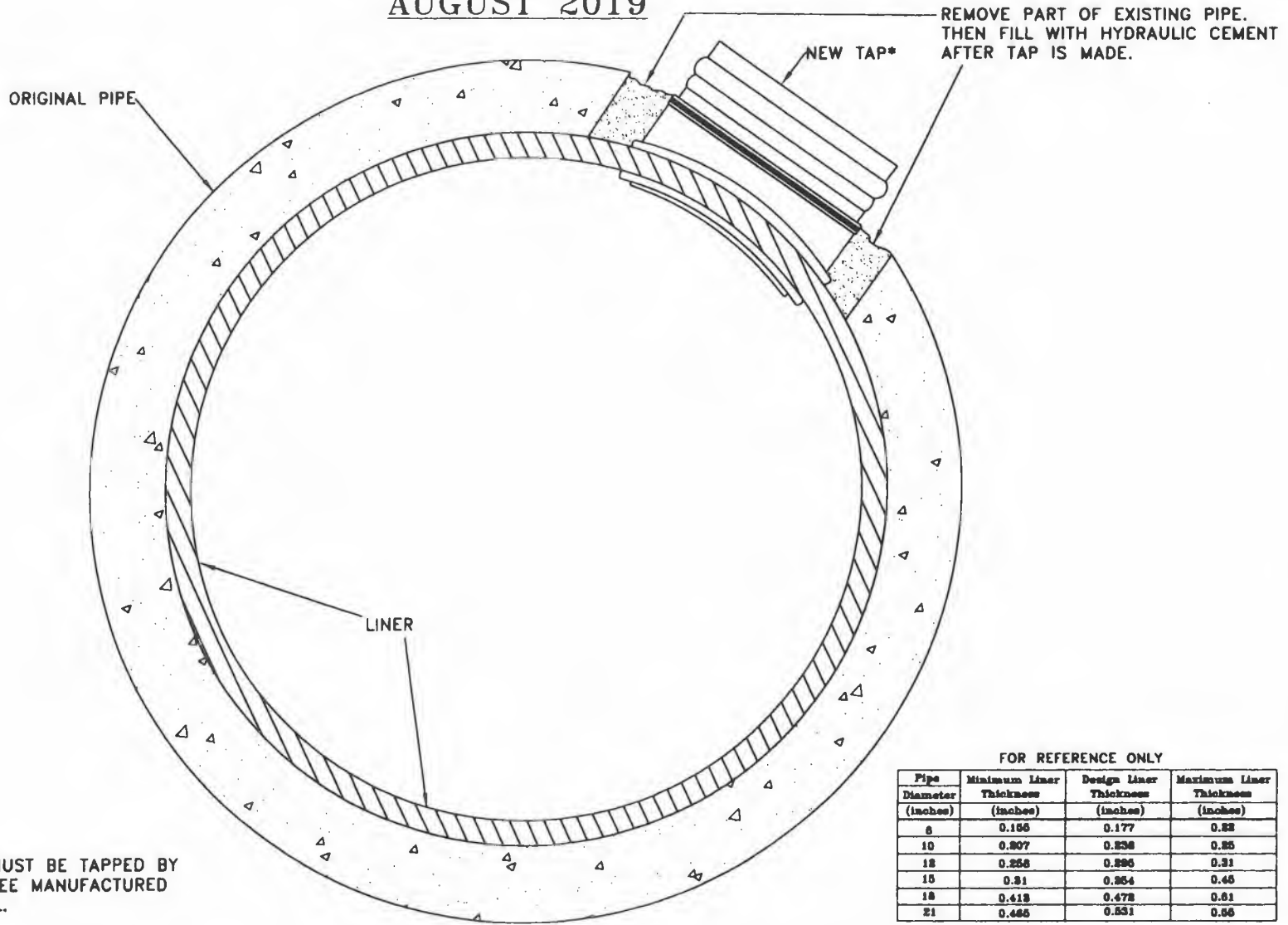

\*ALL LINED PIPE MUST BE TAPPED BY USE OF INSERTA TEE MANUFACTURED BY ADS, OR EQUAL.

FOR REFERENCE ONLY

Pipe Diameter (inches)	Minimum Liner Thickness (inches)	Design Liner Thickness (inches)	Maximum Liner Thickness (inches)
6	0.155	0.177	0.22
10	0.207	0.238	0.28
12	0.258	0.295	0.31
15	0.31	0.354	0.45
18	0.413	0.472	0.51
21	0.465	0.531	0.56

**ERIE COUNTY**  
**DEPT. OF ENVIRONMENT & PLANNING**  
**DIVISION OF SEWERAGE MANAGEMENT**

Rev. 1	
Rev. 2	
Rev. 3	
Rev. 4	
File:Tapped Lined Pipe.dwg	Date: 8/7/19

**STD. DETAIL**  
**21/22A**

# Tap Saddle Install on CIPPL Pipes

(NOVEMBER 2023)

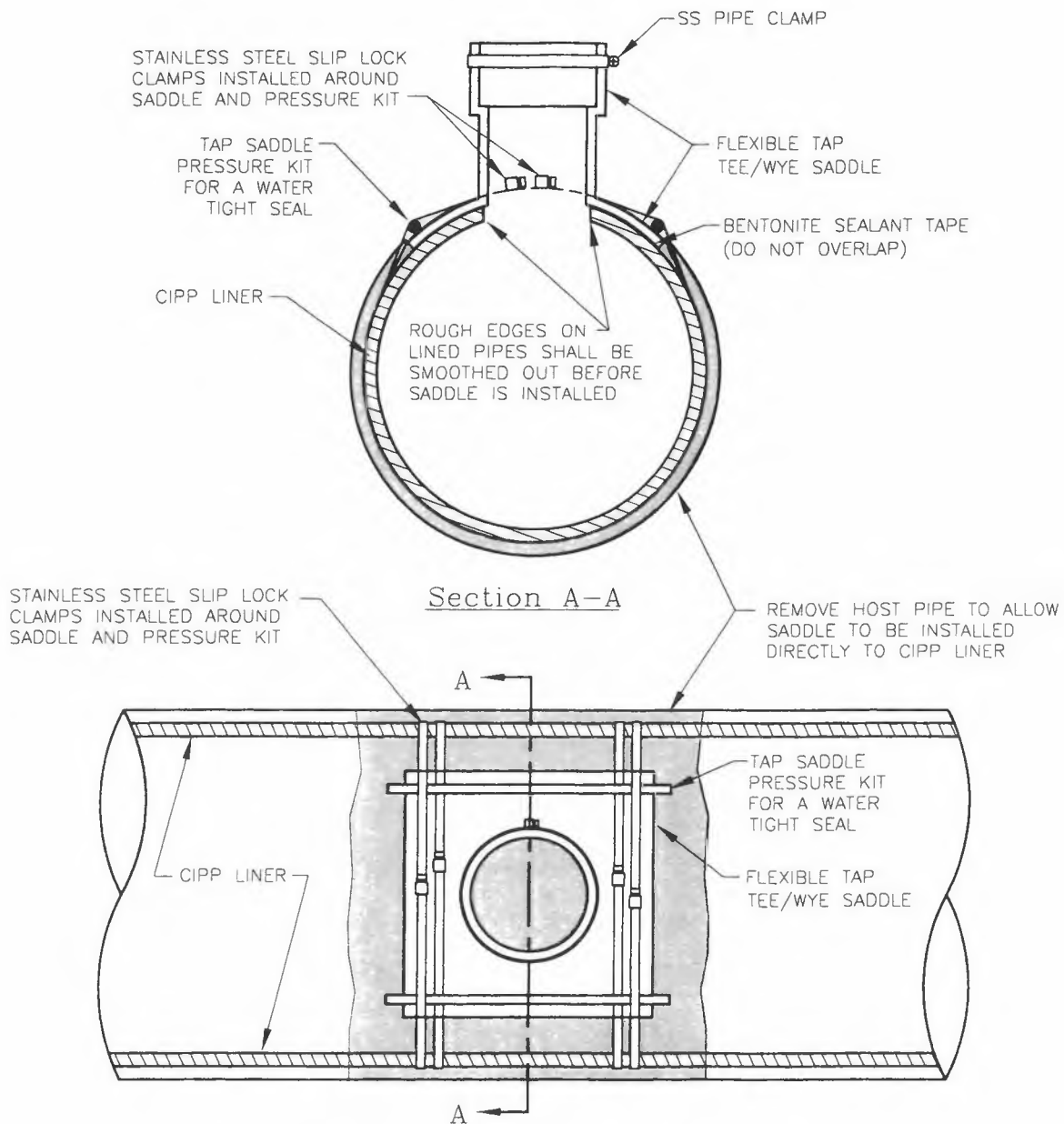

NOTES:

- 1) FLEXIBLE TAP SADDLE SHALL BE FERNCO MODEL TST-4, TST-6, TSW-4, OR TSW-6, WITH TSPK-46 PRESSURE KIT, OR APPROVED EQUIVALENT.
- 2) FOR NEW LATERAL TAP-IN CONNECTIONS, LINED PIPE SHALL BE CORE DRILLED.
- 3) WHERE EXISTING LATERAL TAPS ARE LESS THAN 6" DIAMETER, CONNECTION SHALL BE MODIFIED/ENLARGED TO 6" DIAMETER UNLESS APPROVED BY ENGINEER.

ERIE COUNTY  
DEPT. OF ENVIRONMENT & PLANNING  
DIVISION OF SEWERAGE MANAGEMENT

Rev. 1	
Rev. 2	
Drawn by: W.J.L.	Scale: NTS
File: D-21&22B	Date: NOV-23

STD. DETAIL  
21&22B

# TYPICAL CROSS SECTION OF HIGHWAY CROSSING FOR HOUSE/ COMMERCIAL LATERALS (JANUARY 2012)

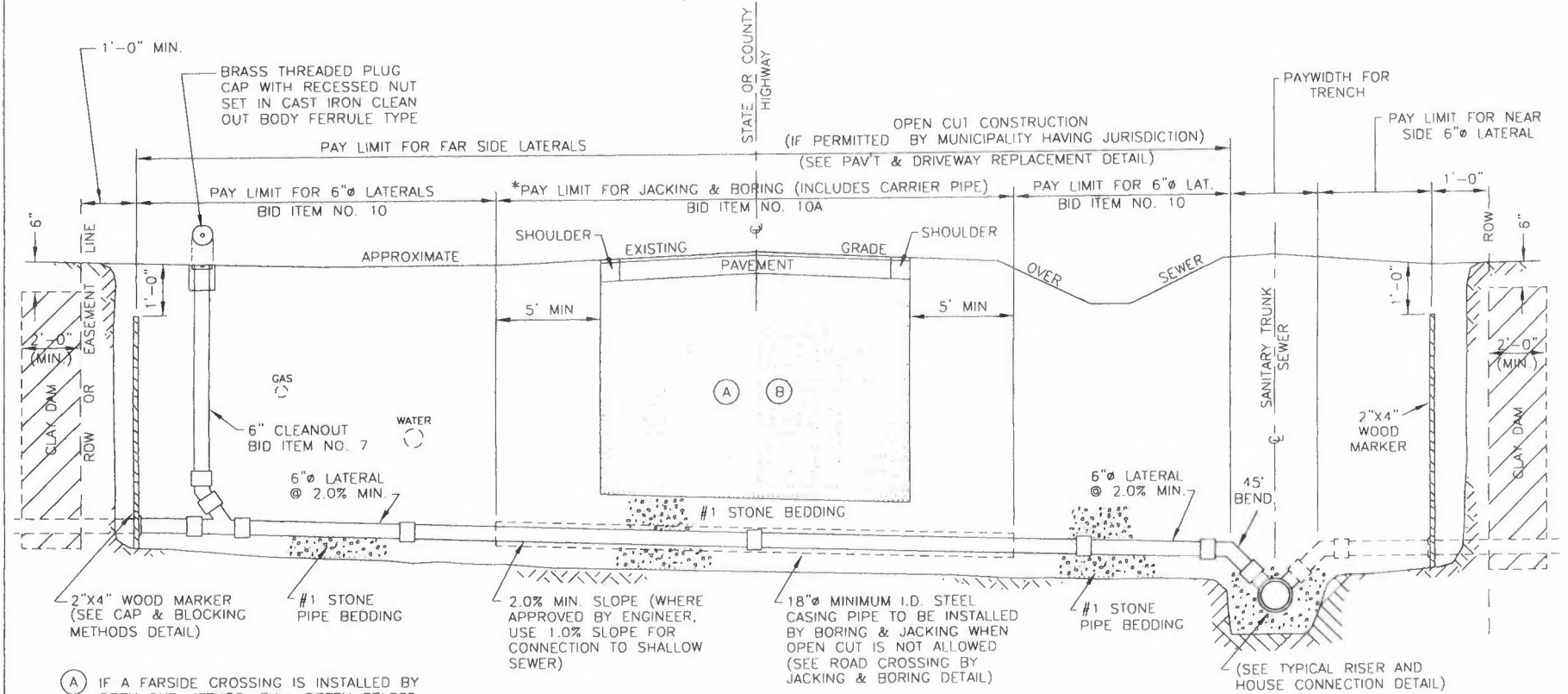

- (A) IF A FAR SIDE CROSSING IS INSTALLED BY OPEN CUT METHOD, FULL DEPTH SELECT FILL MATERIAL SHALL BE REQUIRED UNDER PAVEMENT & SHOULDER AREA AS DESCRIBED IN SECTION 01020- ITEM15 DESCRIPTION OF BID ITEMS-ECDEP SPECIFICATIONS.
- (B) NO. 2 RUN OF CRUSHER STONE WITH A GRADATION CONFORMING WITH NYSDOT SECTION 304-2.02 TYPE 4 AND NYSDOT SECTION 703-02 (LATEST EDITION) COMPACTED IN 6" LIFTS TO 90% DENSITY.

NOTE:  
SHEETING, SHORING MATERIALS OR SHIELD SYSTEM NOT SHOWN.

- \* LENGTH OF PAY LIMIT FOR JACKING AND BORING VARIES IN ACCORDANCE WITH DIMENSIONS SHOWN ON THE PLAN SHEETS.
- \* CONCRETE ENCASEMENT IF COVER DEPTH IS LESS THAN 4'-0" UNDER PAVED AREAS (SEE TYP. CONCRETE ENCASEMENT DETAIL)

\* CLEAN OUTS MUST BE INSTALLED IN LAWN AREAS, NOT IN SIDEWALK OR DRIVEWAY AREAS UNLESS DIRECTED BY ENGINEER

**ERIE COUNTY  
DEPT. OF ENVIRONMENT & PLANNING  
DIVISION OF SEWERAGE MANAGEMENT**

REVISIONS	
6/9/92	ADDED CLAY DAM
3/19/93	OPEN CUT CLARIFICATION
	ADDED CLAY DAM DIMENSIONS
2/7/94	CHANGED NOTES 1 & 2 TO A & B
7/14/99	1" SELECT FILL OVER PIPE
12/01	ADDED NOTE ON LOCATION OF VENTS & C.O
File:	d-24
Date:	3/1/91

STD. DETAIL  
**24**

# CLEAN-OUT DETAIL FOR SERVICE CONNECTION (JANUARY 2012)

**NOTES:**

1. BID ITEM 7 SHALL INCLUDE FURNISHING AND INSTALLING 6" WYE, 6" ELBOW, 6" PIPE (VERTICAL), CLEAN OUT BODY AND BRASS PLUG.
2. HOUSE LATERAL INSTALLATION SHALL BE FIGURED UNDER BID ITEM 10.
3. CLEAN OUT BODIES SHALL BE STANDARD CAST IRON FERRULE TYPE AND CLEAN OUT PLUG SHALL BE BRASS.
4. ALL PAVEMENT CROSSINGS (OPEN CUT METHOD) WITH LESS THAN 4'-0" COVER SHALL BE ENCASED WITH 2000 PSI CONCRETE.
5. CLEAN-OUTS ARE REQUIRED AS SHOWN ON PLANS.
6. SHEETING, SHORING MATERIALS OR SHIELDS SYSTEMS NOT SHOWN.
7. CLEAN OUTS MUST BE INSTALLED IN LAWN AREAS, NOT IN SIDEWALK OR DRIVEWAY AREAS UNLESS DIRECTED BY ENGINEER.

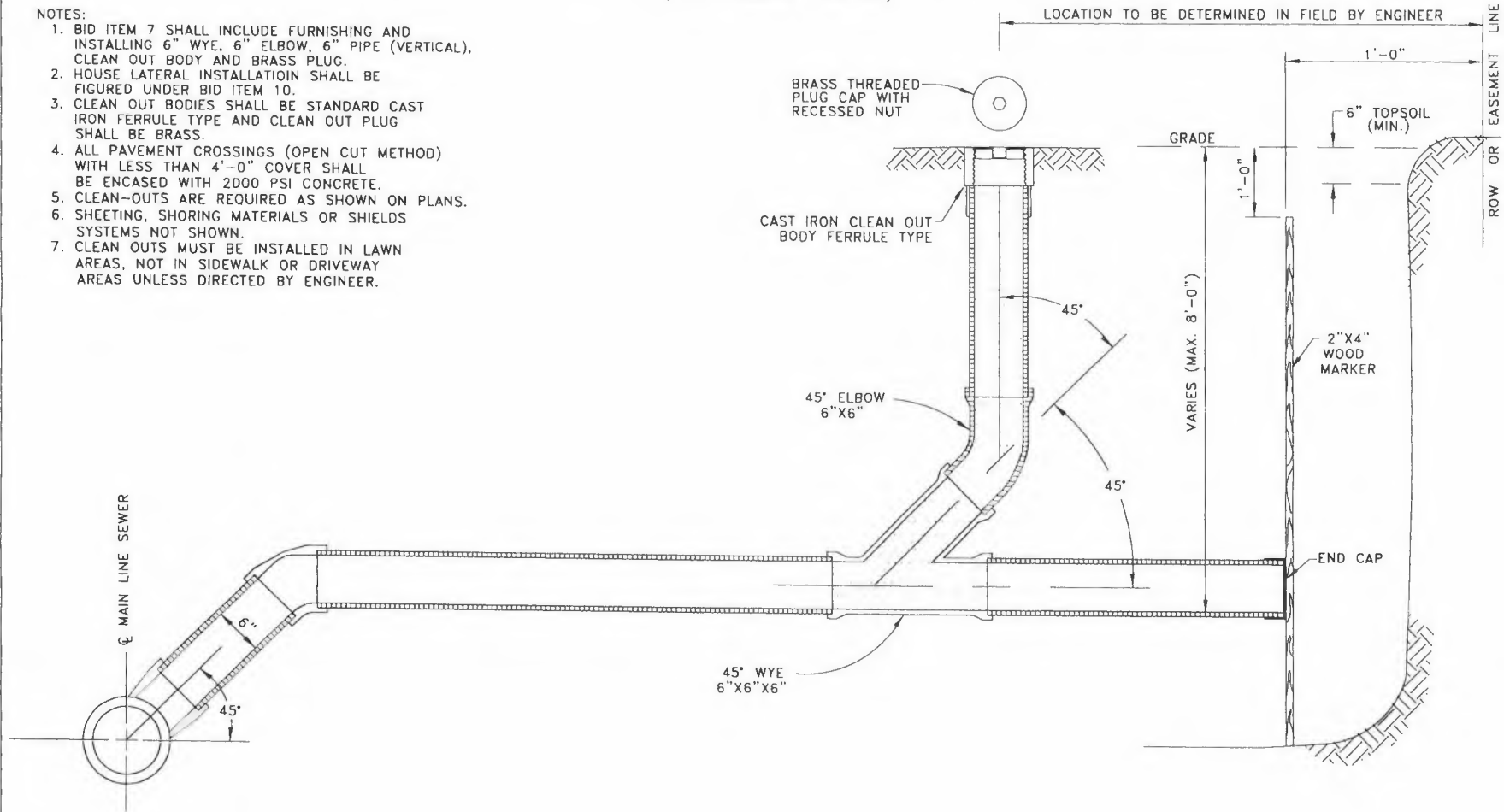

**ERIE COUNTY**  
**DEPT. OF ENVIRONMENT & PLANNING**  
**DIVISION OF SEWERAGE MANAGEMENT**

Rev. 1	5/93	4'-0" COVER, C.I. CAP "RECESSED NUT"
Rev. 2	2/94	CHANGED DIM LINE FOR MAX. DEPTH
Rev. 3	12/01	ADDED NOTE 7
Rev. 4	5/02	CHANGED C.I. CAP TO BRASS
Rev. 5	6/05	1' MIN. FROM EDGE OF WALK NOTE
Rev. 5	1/12	CHANGED C.I. TO BRASS NOTES 1 & 3

STD. DETAIL

28

File: d-28      Date: 3/1/91



# GRINDER PUMP FORCE MAIN CONNECTION TO GRAVITY SEWER LINE DETAIL

(JANUARY 2012)

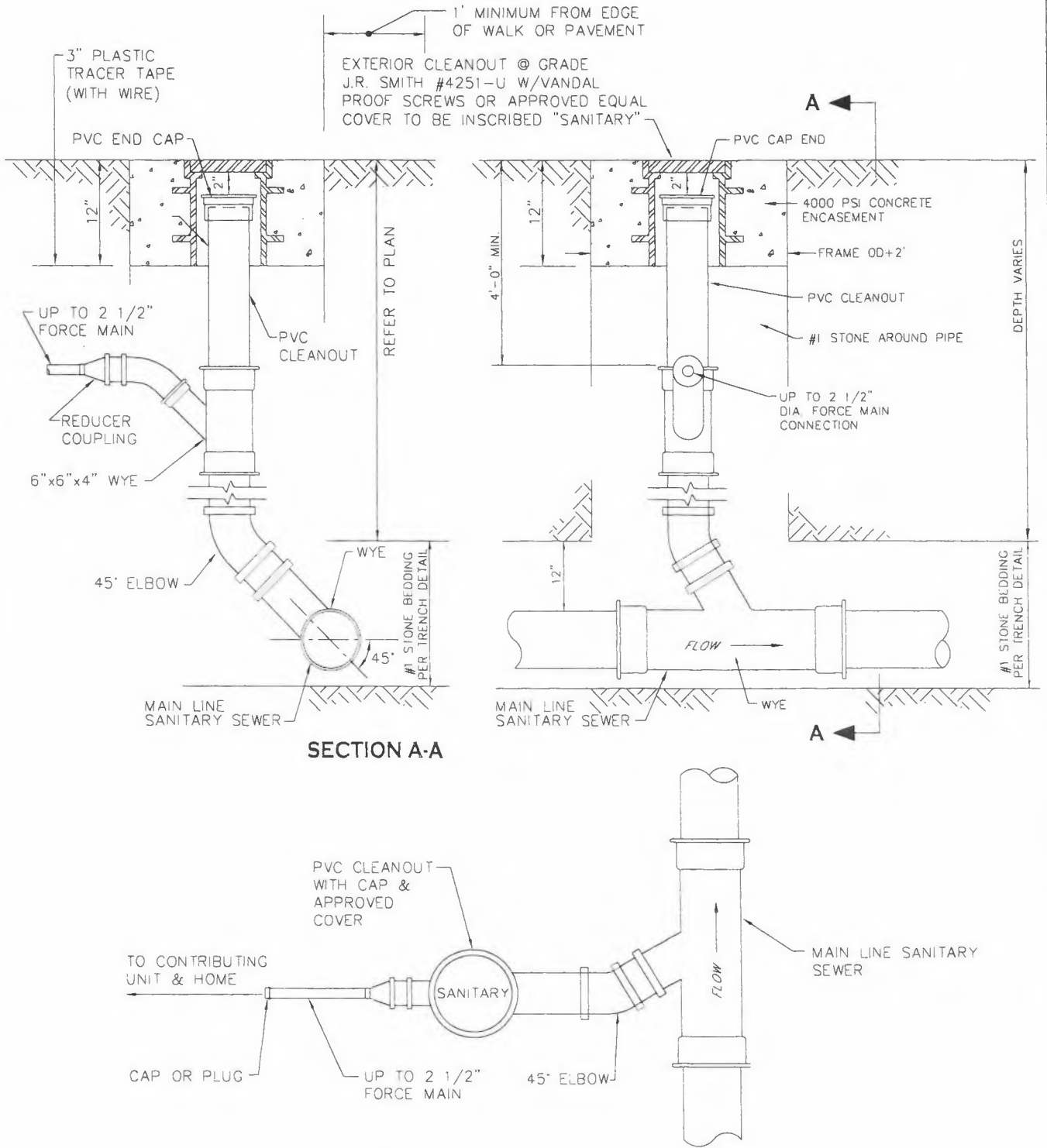

ERIE COUNTY  
DEPT. OF ENVIRONMENT & PLANNING  
DIVISION OF SEWERAGE MANAGEMENT

Rev. 1

Rev. 2

File: d-32a

Date: 6/29/05

STD.DETAIL

32a

# SANITARY SEWER PIPE & MANHOLE ABANDONMENT

(NOVEMBER 2023)

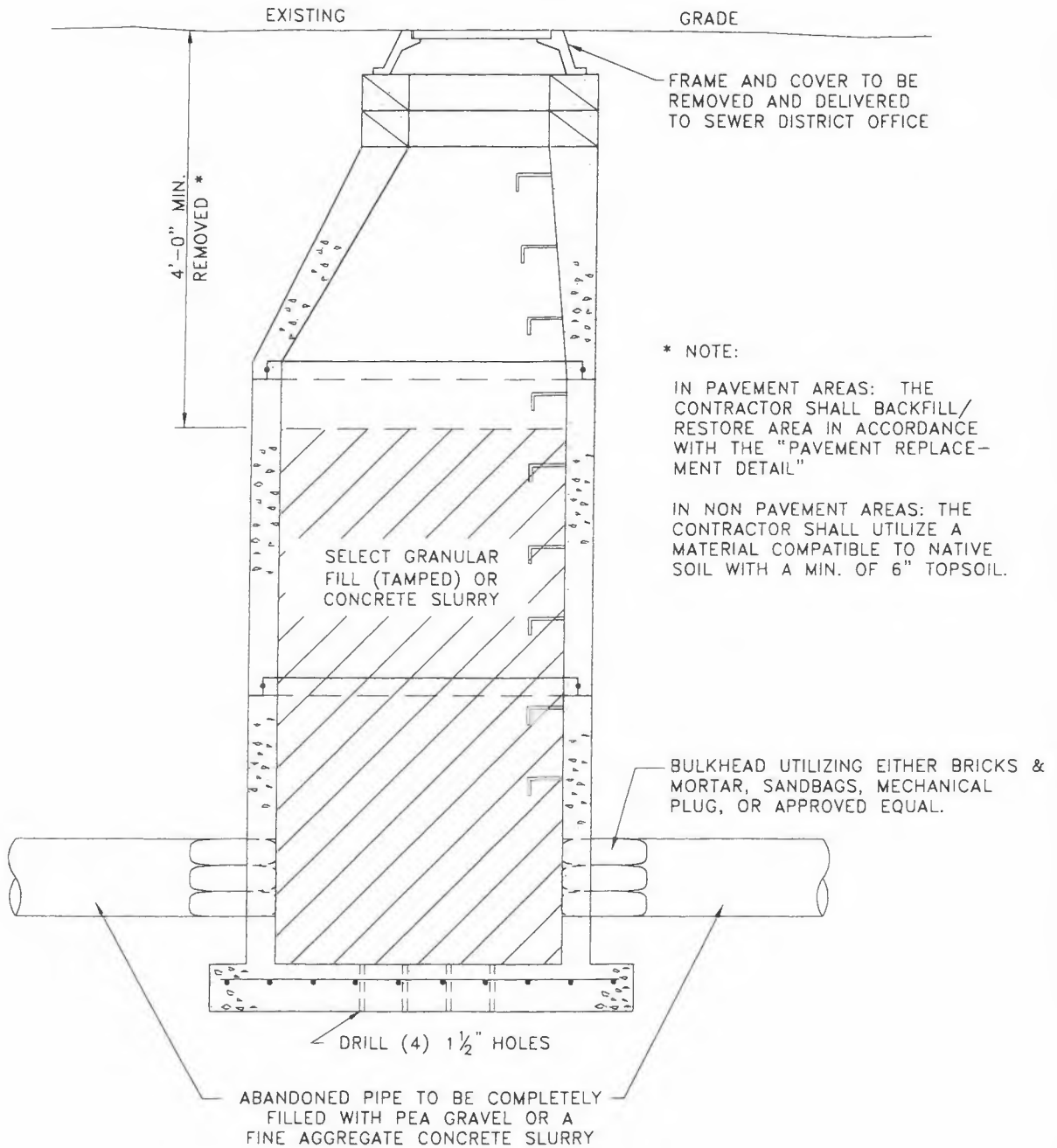

V:\DSM\Engineering\CAD\Details\November 2023\0-33.dwg, Model, 2023/11/17 02:48 pm

**ERIE COUNTY**  
DEPT. OF ENVIRONMENT & PLANNING  
DIVISION OF SEWERAGE MANAGEMENT

Rev. 1	ADDED TAMPED TO SELECT GRANULAR FILL	
2/7/94		
Rev. 2	REMOVED NYS DOT ITEM 203.07 AND ADDED CONCRETE SLURRY	
11/13/23		
File:	d-33	Date: 7/18/91

STD.DETAIL

33

# PRECAST DOGHOUSE BASE MANHOLE

(JANUARY 2012)

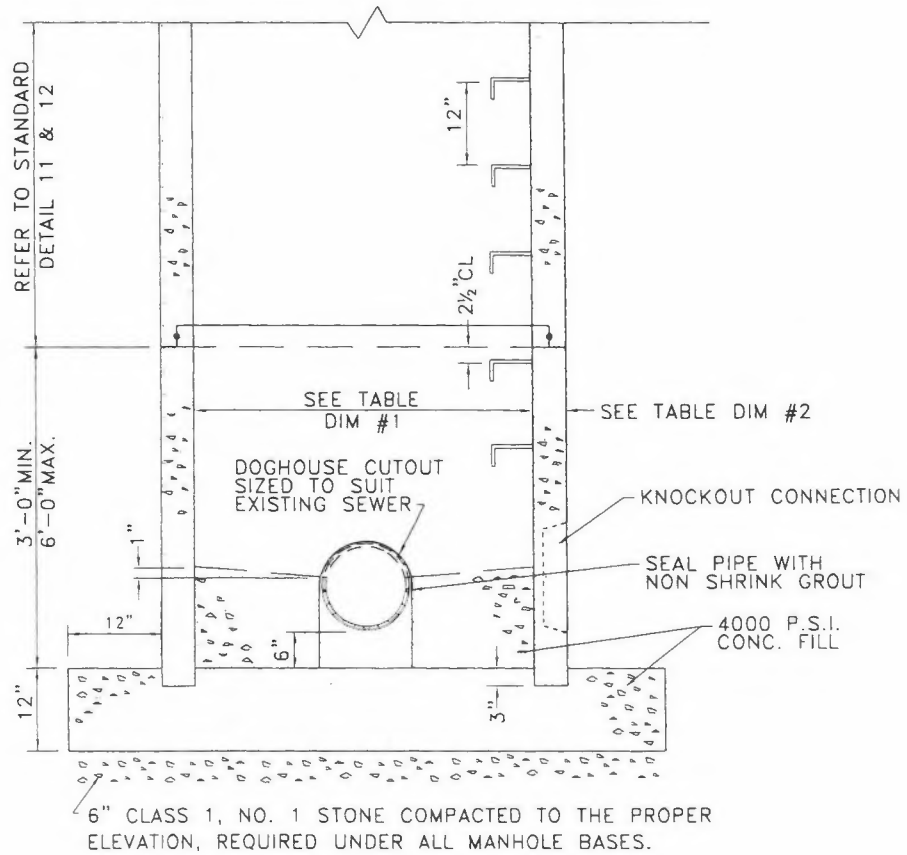

PIPE SIZE	DIMENSION #1	DIMENSION #2
8"-16"	4'-0"*	5"
18"	5'-0"	6"
21"-27"	5'-0"	6"
30"-36"	6'-0"	7"

\* FOR DROP CONNECTIONS INSIDE DIAMETER SHALL BE 5'-0"

**NOTE:**

AREA AROUND DOGHOUSE CUTOUT & PIPE TO BE MADE WATERTIGHT UTILIZING A HYDRAULIC CEMENT MIXTURE (WATERPLUG, PRECO-PATCH, OR APPROVED EQUAL).

ERIE COUNTY  
DEPT. OF ENVIRONMENT & PLANNING  
DIVISION OF SEWERAGE MANAGEMENT

Rev. 1 11/08/91	ADDED PIPE SIZE CHART & NOTE
Rev. 2 2/7/94	REVISED STONE UNDER MANHOLE BASE TO CLASS 1, NO. 1
File: d-35	Date: 10/16/91

STD.DETAIL

35

# CONNECTION TO EXISTING MANHOLE

(JANUARY 2012)

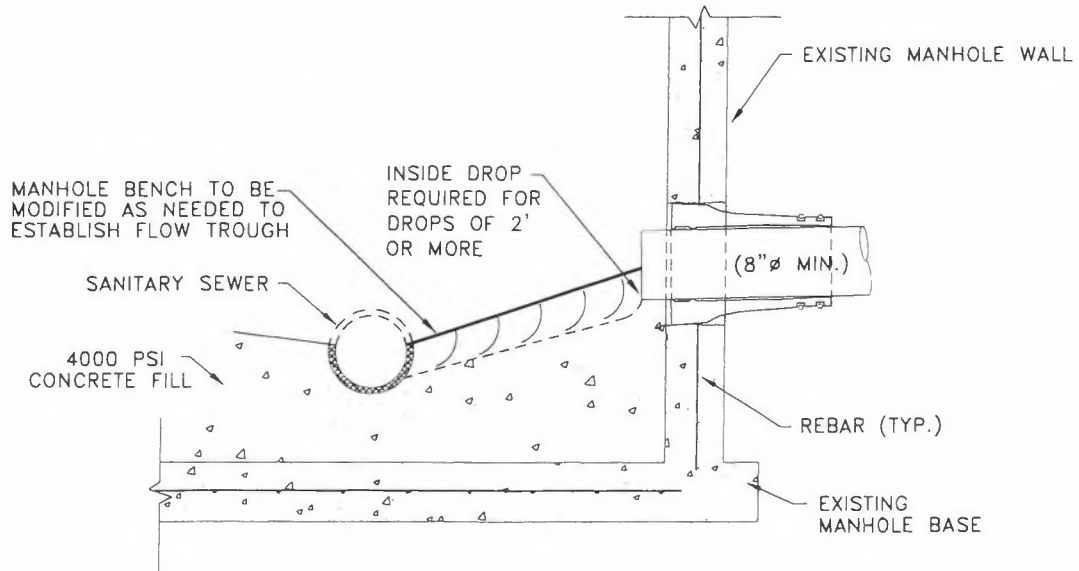

**NOTES:**

1. CORE DRILL ENTRANCE HOLE IN PRECAST MANHOLE BARREL, BASE AND/OR BENCH FOR REQUIRED PIPE CLEARANCE. PER MANUFACTURERS RECOMMENDATIONS.
2. DOES NOT APPLY TO HOUSE LATERALS.
3. WATERTIGHT PIPE TO MANHOLE BOOT SEAL REQUIRED FOR ALL CORE DRILLED ENTRANCE HOLES IN MANHOLE BARREL AS SHOWN BELOW.

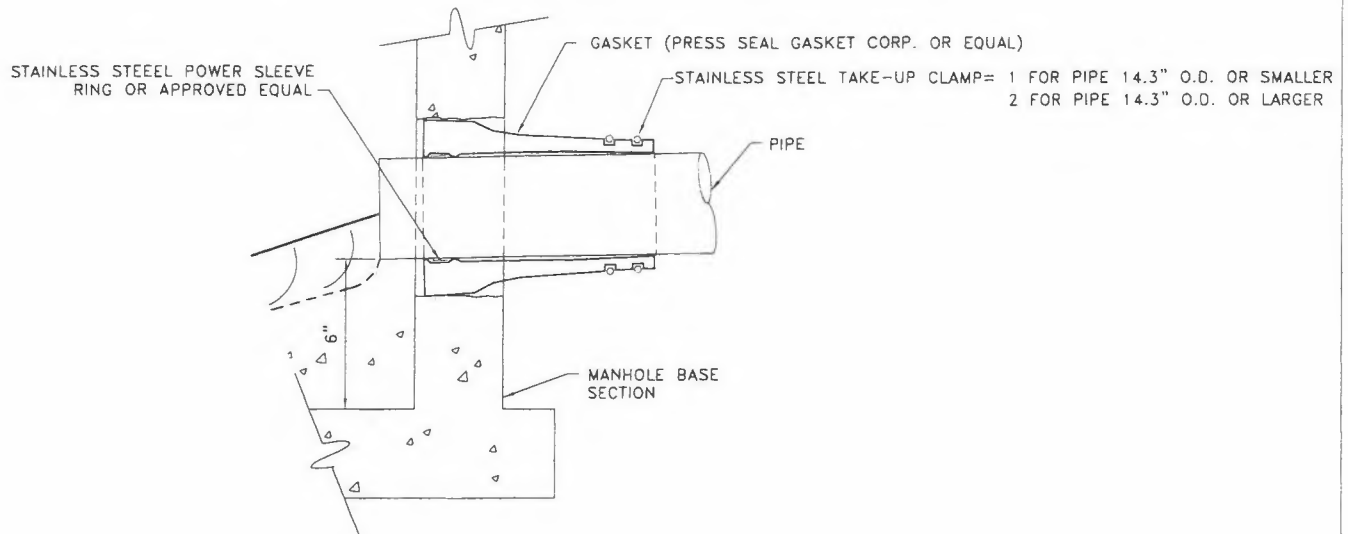

**ERIE COUNTY**  
**DEPT. OF ENVIRONMENT & PLANNING**  
**DIVISION OF SEWERAGE MANAGEMENT**

Rev. 1	ADDED MH BOOT SEAL DETAIL AND NOTE.	
12/9/96		
Rev. 2		
File: d-37	Date: 4/15/93	

STD.DETAIL

37

# EXISTING CLEANOUT REMOVAL

(JANUARY 2012)

EXISTING CLEANOUT TO BE REMOVED.  
CAP TO BE RETURNED TO SEWER DISTRICT

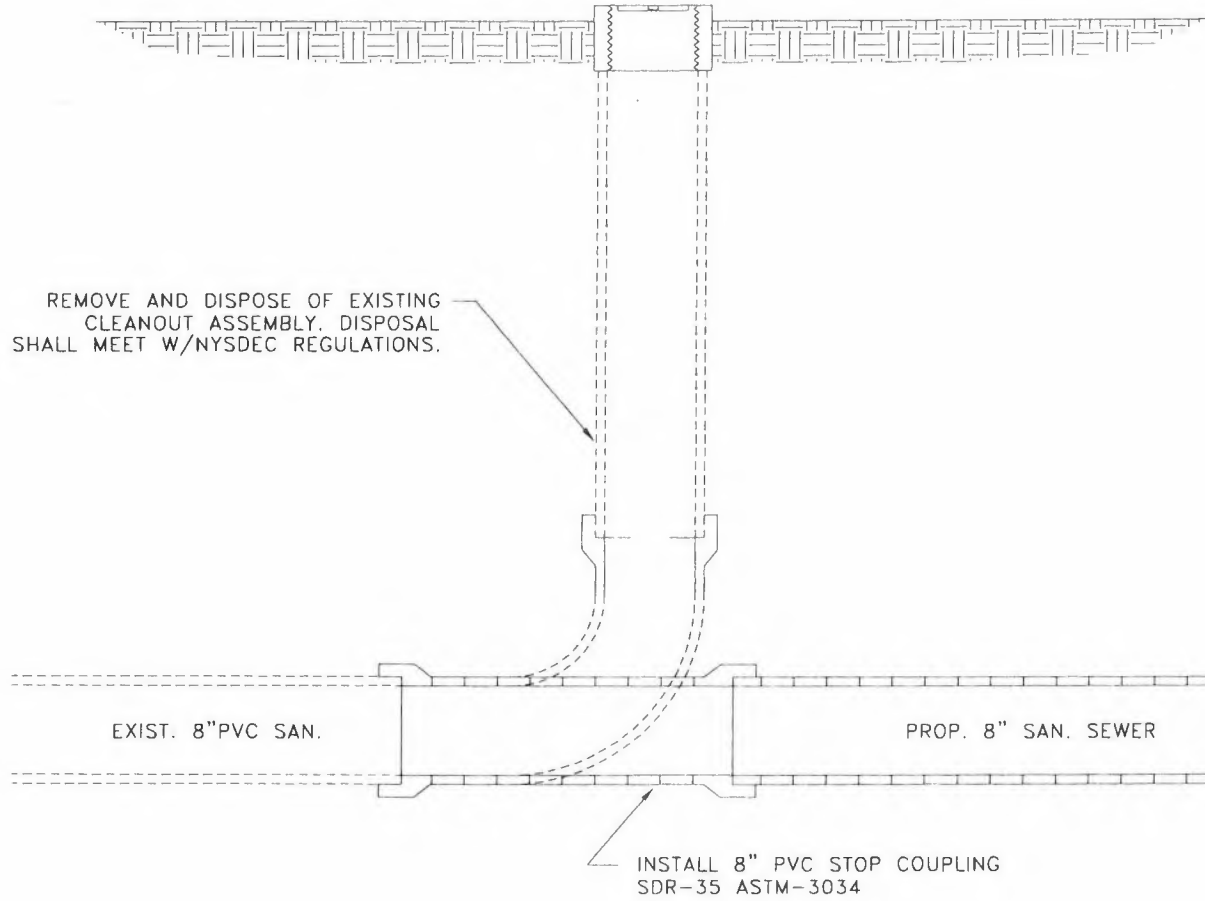

ERIE COUNTY  
DEPT. OF ENVIRONMENT & PLANNING  
DIVISION OF SEWERAGE MANAGEMENT

Rev. 1

Rev. 2

File: d-52

Date: 12/6/96

STD. DETAIL

52

# Cleanout in Pavement/Sidewalks

## Non Residential and Commercial Projects

(NOVEMBER 2023)

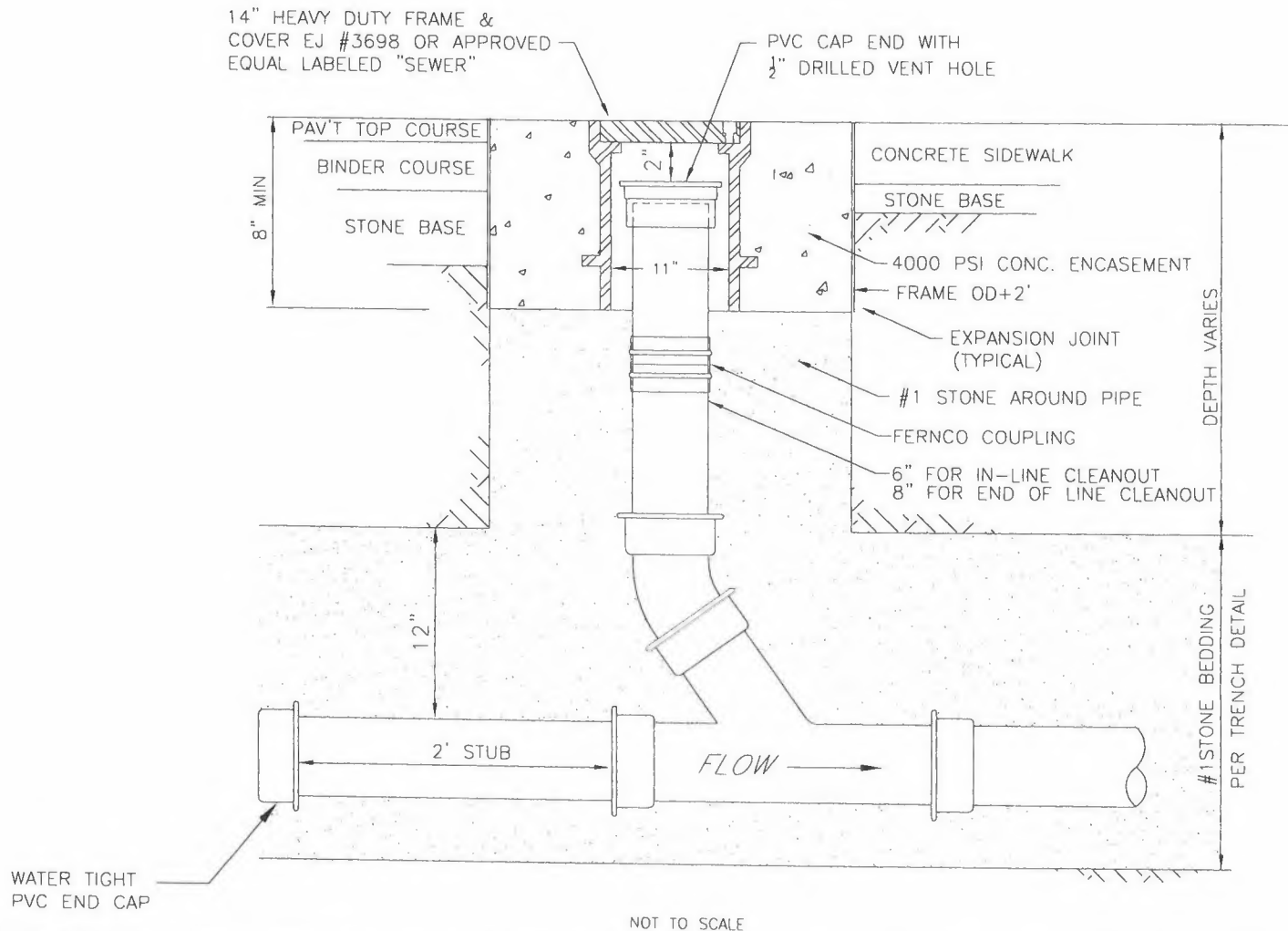

V:\DSM\Engineering\CAD\Details\November 2023\D-53.dwg, Model, 2023/11/20 11:07 am

**ERIE COUNTY**  
**DEPT. OF ENVIRONMENT & PLANNING**  
**DIVISION OF SEWERAGE MANAGEMENT**

REV 07/99	ADD MIN. DISTANCE AND MARKER
REV 12/01	ADDED #1 STONE AROUND PIPE
REV 01/12	REMOVED 2X4 MARKER
REV 11/23	ADD FERNCO COUPLING & EJ 3698
<b>File: D-53</b>	<b>Date: 5/13/97</b>

**STD. DETAIL**  
53

# CLEANOUT DETAIL END OF LINE (NOVEMBER 2023)

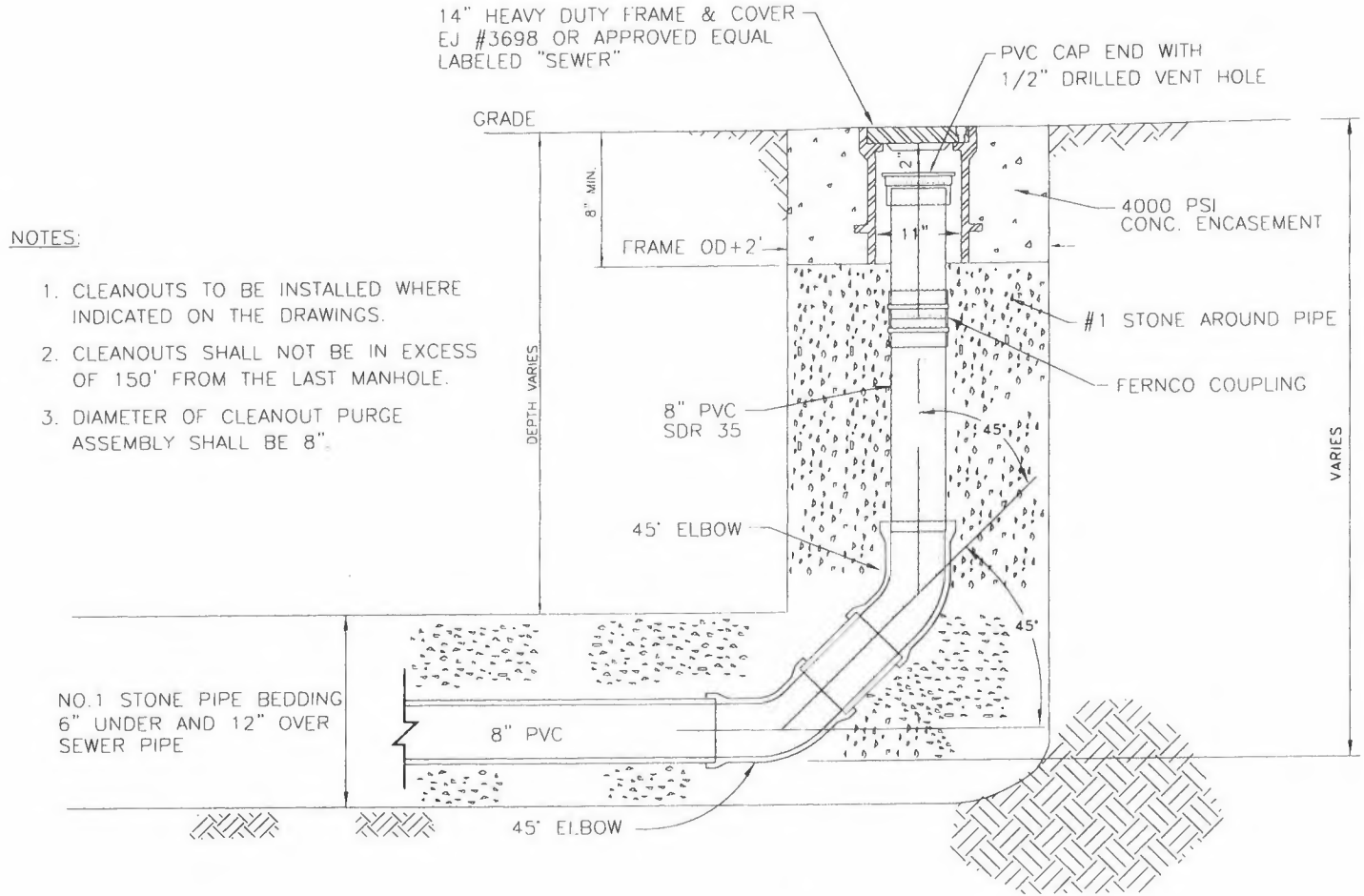

**NOTES:**

1. CLEANOUTS TO BE INSTALLED WHERE INDICATED ON THE DRAWINGS.
2. CLEANOUTS SHALL NOT BE IN EXCESS OF 150' FROM THE LAST MANHOLE.
3. DIAMETER OF CLEANOUT PURGE ASSEMBLY SHALL BE 8".

v:\DSM\Engineering\CAD\Details\November 2023\D-54.dwg, Model, 2023/11/20 11:09 am

**ERIE COUNTY  
DEPT. OF ENVIRONMENT & PLANNING  
DIVISION OF SEWERAGE MANAGEMENT**

Rev. 1	11/23	ADDED FERNCO COUPLING & EJ #3698
File:	D-54	Date: 8/2005

STD. DETAIL

54

# CLAY DAM RELIEF PIPE

(JANUARY 2012)

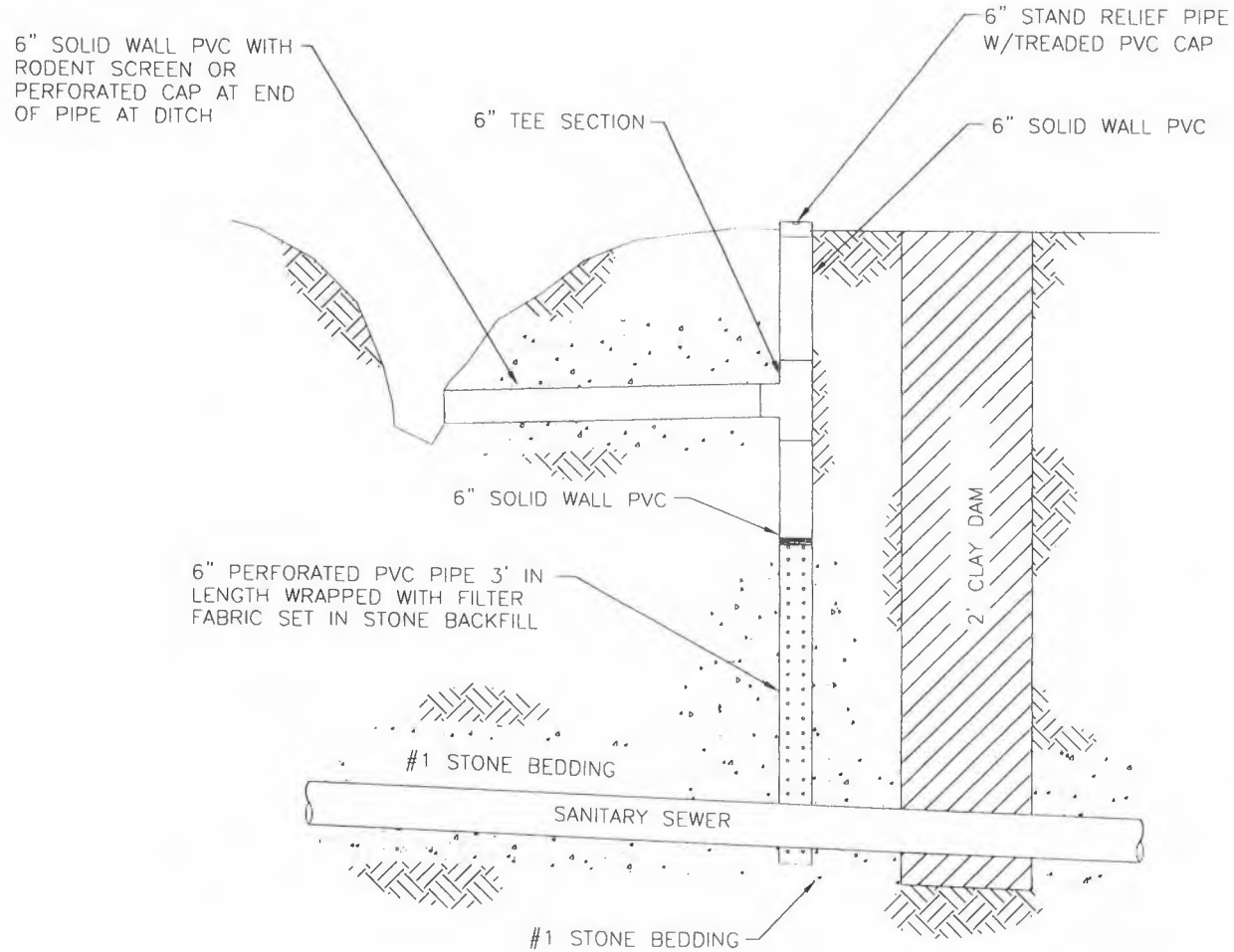

ERIE COUNTY  
 DEPT. OF ENVIRONMENT & PLANNING  
 DIVISION OF SEWERAGE MANAGEMENT

Rev. 1	
Rev. 2	
Rev. 3	
File:	d-55
Date:	12/2001

STD. DETAIL

55





# LAWN DRAIN

NO SCALE

NOTES: 6" PVC OUTLET BASIN MOD. NDS101GKIT (ONE OUTLET) OR MOD. NDS201GKIT (TWO OUTLETS) AS MANUFACTURED BY NATIONAL DIVERSIFIED SALES, OR APPROVED EQUAL.  
8" OR LARGER PVC OUTLET BASINS, NYLOPLAST ADS AS MANUFACTURED BY ADS, OR APPROVED EQUAL.

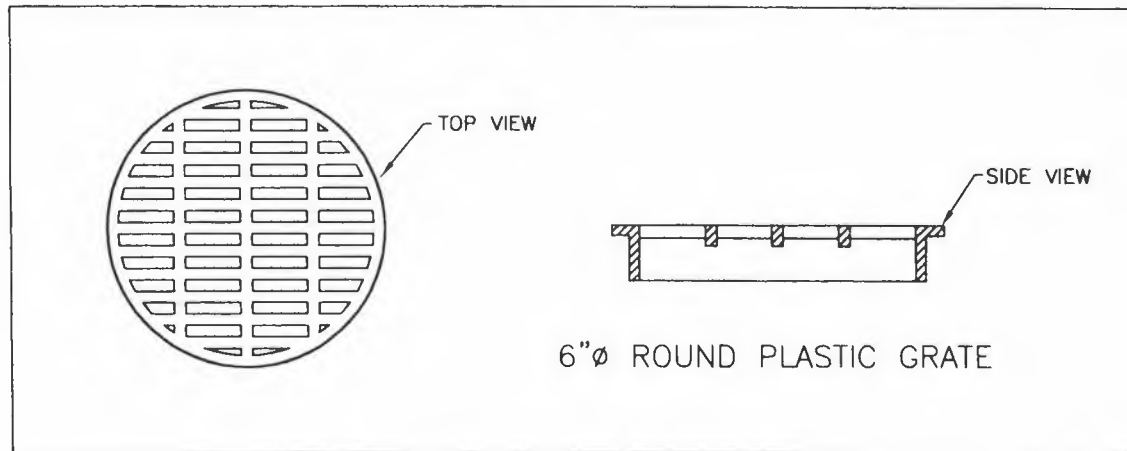
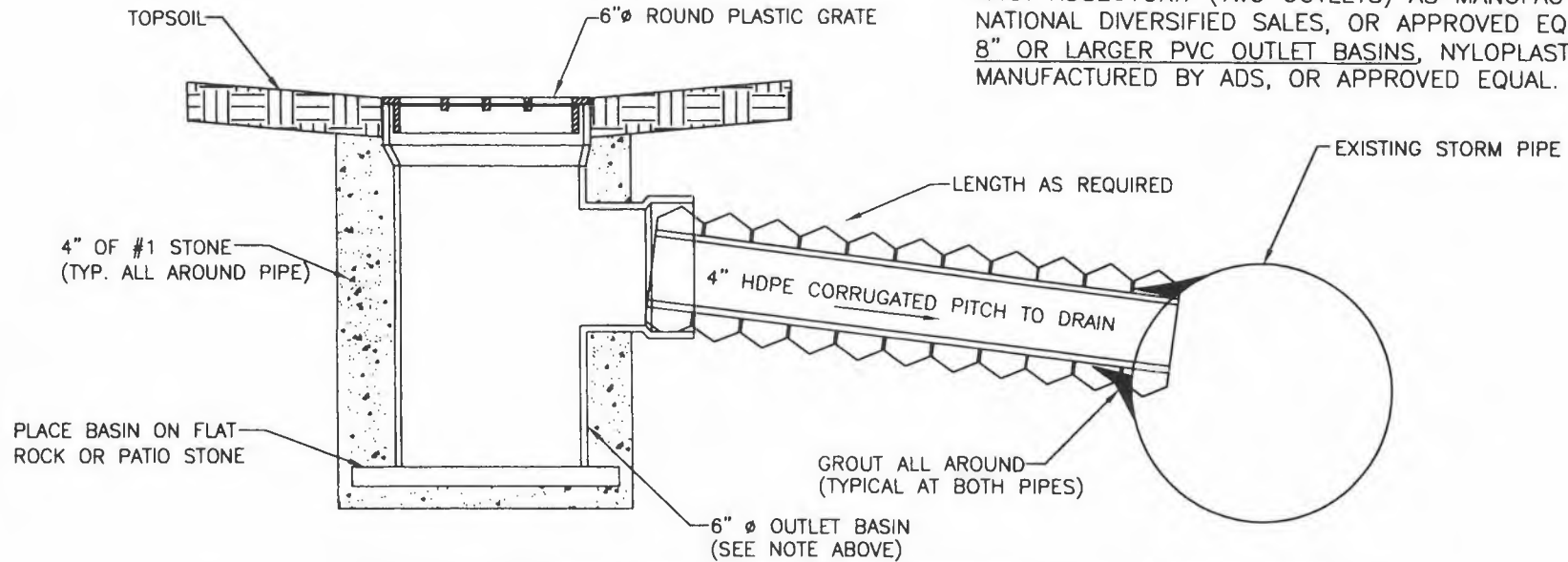

ERIE COUNTY  
 DEPT. OF ENVIRONMENT & PLANNING  
 DIVISION OF SEWERAGE MANAGEMENT

Rev. 1

Rev. 2

File:d-57

Date: 01/28/03

STD. DETAIL





**COUNTY OF ERIE**

**MARK C. POLONCARZ  
COUNTY EXECUTIVE**

**DIVISION OF PURCHASE**

TO: ALL BIDDERS  
FROM: James D. Kucewicz, Buyer  
Erie County Division of Purchase  
DATE: December 21, 2023  
SUBJECT: ADDENDUM NO. 1 Erie County Bid #230311-002  
Sanitary Sewer Open Cut Repair

The attention of all bidders is directed to the following changes in the above bid:

\*\*\*\*\*

The attached pages are part of the bid document

\*\*\*\*\*

ADDENDUM NO. 1

COUNTY OF ERIE  
DEPARTMENT OF ENVIRONMENT AND PLANNING  
ERIE COUNTY SEWER DISTRICT NO. 1, 2, 3, 4, 5, 6, & 8  
CONTRACT NO. 96  
SANITARY SEWER OPEN CUT REPAIR TERM CONTRACT (2024-2026)

Acknowledge receipt of this Addendum in the space provided on the Bid Form. Failure to do so may subject the Bidder to disqualification for award of the associated Contract.

This Addendum consists of 9 pages including attachments, if any, listed on this page.

ADDENDUM No. 1

Additions and Modifications  
SPECIFICATIONS

1. **Section 01 32 33 Photographic Documentations (5 pages) was omitted from Specifications.**
  - Add attached 5 pages to Technical Specs following page 01 32 16-4
2. **Invitation to Bid, Exhibit “D”: Bid Bond (Formal Bid)**
  - Remove Exhibit “D” and replace with the enclosed. The replacement Exhibit “D” must be submitted with the bid.
  - This modifies the bid bond value from 5% of total bid to **\$10,000.00**.
3. **Invitation to Bid, Exhibit “P”: Performance Bond**
  - Remove Exhibit “P” and replace with the enclosed. The replacement Exhibit “P” must be submitted with the bid.
  - This modifies the performance bond value from 100% of total bid to **\$500,000.00**.
4. **Section 00 41 13, Bid Form: Page 8 of 15**
  - Remove this page and replace with the enclosed. The replacement Page 8 of 15 must be submitted with the bid.
  - This modifies Contract Quantities for Bid Items 27A through 27I and corrects typos in the minimum prices for a few items.

End of Addendum

Enclosures

CHANGES TO BIDDING REQUIREMENTS (3 pages)  
CHANGES TO SPECIFICATIONS (5 pages)

Item No.	Description	Unit	Quantity	Minimum Unit Price	Bid Unit Price	Bid Amount
25A	CCTV Inspection (8" to 12")	LF	100	\$3.00		
25B	CCTV Inspection (12" to 24")	LF	50	\$4.00		
25C	See Snake Inspection	HR	5	\$50.00		
26A	Traffic Control – Flagperson (Per Hour)	HR	8	\$60.00		
26B	Traffic Control – Flagperson (Per Week)	WEEK	1	\$2,500.00		
27A	Portable Advance Warning Arrow Panel (Rental Per Day)	DAY	10	\$100.00		
27B	Portable Advance Warning Arrow Panel (Rental Per Week)	WEEK	2	\$300.00		
27C	Portable Traffic Signals (Rental Per Day)	DAY	10	\$450.00		
27D	Portable Traffic Signals (Rental Per Week)	WEEK	2	\$1,500.00		
27E	Attenuator Truck (Rental Per Day)	DAY	10	\$100.00		
27F	Attenuator Truck (Rental Per Week)	WEEK	2	\$300.00		
27G	Type III Barricade (Rental Per Day)	DAY	10	\$25.00		
27H	Type III Barricade (Rental Per Week)	WEEK	2	\$100.00		
27I	Traffic Control Device Delivery/Set Up/Removal	EA	20	\$200.00		
27J	Traffic Control Work Plan Development	EA	10	\$250.00		
28A	Asbestos Abatement, Handling, and Disposal (Hourly)	HR	16	\$375.00		
28B	Asbestos Abatement, Handling, and Disposal (Daily)	DAY	2	\$3,000.00		
	<b>PART 2 TOTAL</b>	-	-	\$227,205.00 minimum	-	\$

**00 41 13, Bid Form**

This document is a MODIFIED version of EJCDC® C-41, Copyright© 2018 by the National Society of Professional Engineers, American Council of Engineering Companies, and American Society of Civil Engineers, or is based in part on excerpts from copyrighted EJCDC documents. All rights reserved. Those portions of the text that originated in copyrighted EJCDC documents remain subject to the copyright.



# County of Erie

DIVISION OF PURCHASE

## **BID BOND (FORMAL BID)**

**BID BOND OR CERTIFIED CHECK FOR \$10,000 MUST BE SUBMITTED WITH THE BID.** The undersigned agrees that the bid security may be retained by the County until contracts have been signed and Performance Bonds have been delivered to the County, except as provided in Paragraph 23, in the Invitation to Bid. **SHOULD THE SUCCESSFUL BIDDER TO WHOM THE BID IS AWARDED FAIL TO EXECUTE THE AGREEMENT SUBMITTED BY THE COUNTY IN ACCORDANCE WITH THE FORMAL BID AND OTHER CONTRACT DOCUMENTS AND TO FURNISH THE REQUIRED PERFORMANCE BOND WITHIN FOURTEEN (14) CALENDAR DAYS AFTER THE NOTICE OF AWARD, THE CERTIFIED CHECK OR THE BID BOND AMOUNT SHALL BE FORFEITED TO THE COUNTY AS LIQUIDATED DAMAGES CAUSED BY SUCH FAILURE.**

(Rev. 4/1/93)

ERIE COUNTY OFFICE BUILDING, 95 FRANKLIN STREET, BUFFALO, NEW YORK 14202 (716) 858-6395



## County of Erie

### DIVISION OF PURCHASE

### **PERFORMANCE BOND**

The successful bidder or bidders whose proposal is accepted shall, within two weeks after notice of the award, enter into a contract with the County of Erie and furnish a performance bond running to the County of Erie in the Penal amount of **\$500,000.00**. Such bond to be approved by the County of Erie Department of Law and to be executed by the bidder as PRINCIPAL and by a duly incorporated company authorized to guarantee the performance of contracts and to do business in the State of New York as SURETY. The condition of said bond shall read to conform with the County of Erie Performance Bond format without exception, as per County of Erie Form Exhibit "PBI".

( Rev. 4/1/93)



**SECTION 01 32 33**  
**PHOTOGRAPHIC DOCUMENTATION**

PART 1 GENERAL

1.1 SUMMARY

- A. This section includes administrative and procedural requirements for preconstruction photographs, construction photographs, post-construction photographs and videos.
- B. Related Sections:
  - 1. Section 01 33 10 – Submittal Procedures
  - 2. Section 01 77 19 – Closeout Requirements
  - 3. Section 01 77 23 – Post Final Inspection

1.2 SUBMITTALS

- A. Submittals shall conform with the requirements of Section 01 33 10 Submittal Procedures.
- B. Photograph submittals shall be in electronic JPG format, with one hard copy submitted to Owner, and shall include:
  - 1. A plan of project site indicating vantage point, location and direction of each photograph (indicated by arrow). Each photo shall be identified by a unique photo number.
  - 2. A photo log listing:
    - a. Title of Project
    - b. Owner's District and Contract Numbers
    - c. Contractor's name
    - d. Date photo was taken
    - e. Photo number corresponding to that identified on plan of project site
    - f. Description of photograph
    - g. Location information not indicated on plan (e.g. vertical information)
  - 3. Photographs shall be arranged in sheets according to the location the photo was taken on the project site, in date order. Multiple photographs and photographs in varying proximity to the Work shall be provided of critical locations, equipment or activities and may be required by Engineer for areas with known or suspected concerns.
- C. Video submittals shall be submitted on a CD, USB Drive or other transferrable

media and shall include:

1. A video log listing:
    - a. Title of Project
    - b. Owner's District and Contract Numbers
    - c. Contractor's name
    - d. Date video was taken
    - e. Time length of video
    - f. List of video sections/ highlights
      1. Time stamp where section / highlight is located
      2. Description of section / highlight
      3. Reference to pertinent equipment or specification section
  2. Any other materials associated with the video, such as training manuals for training videos or equipment information for operational videos.
- D. Submittals of photographic evidence shall be made at the time of pay request, for all work included in the pay request, unless otherwise stated in the Contract Documents.
- E. In submitting photographs or videos to Owner, Contractor shall also transfer copyright usage rights for unlimited reproduction of that submitted.

### 1.3 PHOTOGRAPHS - GENERAL

- A. Contractor shall provide digital copies of the photographs taken with a minimum 6-megapixel camera.
- B. Photographs shall be verified to be in focus or shall be immediately retaken. Photographs shall be of sufficient quality to be printed in the dimensions of 8 - inches by 10-inches without distortion.
- C. Critical locations, equipment or activities shall have a minimum of four (4) photographs taken from different vantage points and proximity to the Work. Engineer may require additional photographs of areas with known or suspected concerns.
- D. Photographs of the Site shall be taken as well as photographs of specific locations, equipment, and activities.
- E. The minimum number of photographs shall be those listed herein and those directed by Engineer. Contractor may take additional photographs as they deem necessary.

- F. Photographic documentation is used as evidence that the Work has been completed according to the Contract Documents. Engineer may, at his option, take additional photographs but will not be required to make these photographs available to Contractor.
- G. Engineer may use photographic documentation of Defective work in a Notice of Defects. Engineer may also use photographic documentation to settle disputes.

#### 1.4 PRECONSTRUCTION PHOTOGRAPHS

- A. Contractor shall take digital photographs, prior to the start of the Work, at the locations of the Work.
- B. Contractor is responsible to take a sufficient number of preconstruction photographs so as to resolve any disputes which may arise regarding the conditions prior to and subsequent to construction.
- C. Preconstruction photographs shall be submitted to Engineer for approval prior to starting the Work. Preconstruction photographs taken by Contractor will not be considered as part of the number of construction photographs required.
- D. Preconstruction photographs shall include the following:
  - 1. Overall views of the Site.
  - 2. Photos to indicate conditions prior to the start of the Work.
    - a. Structural condition.
    - b. Condition at connections to existing facilities.
    - c. Ground condition.
    - d. Condition of existing facilities adjacent to or involved in the Work.
    - e. Condition of adjacent properties (if close to the Site).
  - 3. Photos of areas that Contractor will use for parking, staging or storage.
- E. Should Engineer deem the number, type and quality of the photographs are insufficient to properly reflect existing conditions, Contractor shall re-take photographs until Engineer's acceptance is received.
- F. If a dispute arises in a location where no preconstruction photographs were taken, the disputed area shall be restored to the extent directed by Engineer and to the complete satisfaction of Engineer.

#### 1.5 CONSTRUCTION PHOTOGRAPHS

- A. Contractor shall take digital photographs weekly, or at such intervals as necessary to provide complete documentation, to demonstrate progress of the Work. Photographs shall be taken at the locations and at such stages of construction to

provide such documentation.

- B. During the Work, photographic documentation is required for all major activities, at appropriate intervals, to provide views representative of work being performed.
- C. A minimum of five (5) photographs per week shall be taken.
- D. Engineer may require additional photographs if Contractor photographs are not accurately demonstrating the progress of the Work.

#### 1.6 POST-CONSTRUCTION PHOTOGRAPHS

- A. Upon completion of the Work, Contractor shall take digital photographs at the locations of the Work.
- B. Post-construction photographs shall be submitted to Engineer for approval prior to closeout. Refer to Section 01 77 19 Closeout Requirements. Post-construction photographs taken by Contractor will not be considered as part of the number of construction photographs required.
- C. Post-construction photographs shall include the following:
  - 1. Overall views of the Site.
  - 2. Photos to indicate end result of the Work.
    - a. Work installed.
    - b. Connections to existing facilities.
    - c. Modified facilities.
  - 3. Photos to indicate the condition after completion of the Work.
    - a. Condition of existing facilities adjacent to or involved in the Work.
    - b. Condition of adjacent properties (if close to the Site).
    - c. Condition of areas that Contractor used for parking, staging or storage.
  - 4. Defects or uncompleted work identified during the final inspection and subsequent repaired or completed work. Refer to Section 01 77 23 Post Final Inspection.
- D. Should Engineer deem the number, type and quality of the photographs are insufficient to properly document the result of the Work or the condition after completion, Contractor shall re-take photographs until Engineer's acceptance is received.

#### 1.7 VIDEOS

- A. Contractor shall provide high-resolution, digital video with a minimum sensor resolution of 12 megapixels with vibration-reduction technology.

- B. Videos shall be verified to be in focus or shall be immediately retaken. Videos shall be of sufficient quality to be viewed on a 17-inch monitor without distortion.
- C. Videos depicting project work or existing conditions shall show a close-up of critical locations, equipment, or activities, or problem areas, at every possible angle and of sufficient length for documentation. Engineer may require additional close-up views of areas with known or suspected concerns.
- D. Video documentation is used as evidence that the Work has been completed according to the Contract Documents.
- E. Engineer may use video documentation of Defective work in a Notice of Defects. Engineer may also use video documentation to settle disputes.

PART 2 PRODUCTS

NOT USED

PART 3 EXECUTION

NOT USED

END OF SECTION

**Response:** This will be addressed in Addendum 1, and this Page will be revised.

7. **Question:** Is it possible to get a copy of the previous contract bid tabulation?

**Response:** DSM has bid similar contracts in recent years including ECSD No. 1-8 Contract 79 (Bid Date: July 27, 2017) and ECSD No. 1-8 Contract 86 (Bid Date: September 27, 2021). Requests for bid tabulation can be sent to through Erie County Purchasing - [James.Kucewicz@erie.gov](mailto:James.Kucewicz@erie.gov) or they can be requested via a Freedom of Information Law request to the Division of Sewerage Management via [SewerFOIL@erie.gov](mailto:SewerFOIL@erie.gov).

8. **Question:** Will you be including the tasks performed from the previous [contracts] that you had mentioned at the pre-bid meeting into the addendum?

**Response:** In the previous contracts mentioned in Question 7, about half of the work orders issued consisted of sanitary sewer spot repairs approximately 10 to 20 linear feet in length. Several manhole to manhole installations were completed between the two contracts including lateral replacements and new cleanouts at the right of way. Manhole installations/replacements were issued under both contracts. Between the two contracts, work was issued in all 7 sewer districts, and on local, State, and County roads. Past work may not be indicative of future work to be assigned. Actual quantities will be based on need, availability of funding, and repair needs discovered during the contract duration. The Bid Form quantities are not guaranteed nor are promises given to the amount of work ordered during the term of the Contract.

End of Document





**COUNTY OF ERIE**

**MARK C. POLONCARZ  
COUNTY EXECUTIVE**

**DIVISION OF PURCHASE**

TO: ALL BIDDERS  
FROM: James D. Kucewicz, Buyer  
Erie County Division of Purchase  
DATE: December 21, 2023  
SUBJECT: ADDENDUM NO. 2 Erie County Bid #230311-002  
Sanitary Sewer Open Cut Repair

The attention of all bidders is directed to the following changes in the above bid:

\*\*\*\*\*

The attached information is in regard to the above bid.

\*\*\*\*\*



**Erie County Sewer District No. 1,2,3,4,5,6,8  
Sanitary Sewer Open Cut Repair Term Contract (2024-2026)  
Contract No. 96**

**Questions Received**

1. **Question:** I downloaded the Specifications from the website and there is a watermark that states "Not for Bidding" on the Bid Form pages.

**Response:** The official copy of the Specifications from the Erie County Division of Purchase website does not have a watermark on any of the pages. Bidders should confirm that they have downloaded the document directly from the Erie County website.

2. **Question:** Is a particular form required for the Bid Bond?

**Response:** There is not a specific bid bond form required to be submitted. The bidder shall submit a bid bond issued by a Surety meeting the requirements of the Contract, or a certified check. The Exhibit "D" Bid Bond sheet was modified by Addendum 1 – refer to modified page and submit this sheet with bid.

3. **Question:** Are the traffic control items intended for work on NYSDOT roads?

**Response:** The traffic control items are primarily intended for work on NYSDOT or Erie County roadways. Refer to Section 01 22 13 – 24 and 01 22 13 – 25.

4. **Question:** Is there a mobilization item?

**Response:** Refer to Section 01 22 13 -37. There is a fixed price bid item intended to be compensated once per Work Order. All other costs associated with mobilizing and demobilizing shall be incorporated into the unit bid prices as applicable.

5. **Question:** What do I need to include with my bid for the Executive Order #18 requirements?

**Response:** Refer to Section 00 73 40, Disadvantaged Worker Requirements, Page 9 of 11, which must be submitted with bid (also referenced on Page 1 of 11 of this same section).

6. **Question:** The fixed minimum unit price total (Part 2 total) on Page 8 of 15 of the Bid Form does not appear to add up correctly.



**COUNTY OF ERIE**

**MARK C. POLONCARZ  
COUNTY EXECUTIVE**

**DIVISION OF PURCHASE**

TO: ALL BIDDERS  
FROM: James D. Kucewicz, Buyer  
Erie County Division of Purchase  
DATE: January 8, 2024  
SUBJECT: ADDENDUM NO. 3 Erie County Bid #230311-002  
Sanitary Sewer Open Cut Repair

The attention of all bidders is directed to the following changes in the above bid:

\*\*\*\*\*

The attached information is in regard to the above bid.

\*\*\*\*\*

Erie County Sewer District No. 1,2,3,4,5,6,8  
Sanitary Sewer Open Cut Repair Term Contract (2024-2026)  
Contract No. 96

Questions Received (12/21/23 to 1/6/24)

1. **Question:** On page 2 of the bid form under Article 3, 3.01B shows: “B. The following contingency allowance is included in the price set forth below. Bid Item No. 32 - Lump Sum Contingency Total \$5,000.00”. This Item is not included in Part 3 of the “FIXED BID PRICES.” How do we include this Contingency Allowance?

**Response:** On page 2 of the Bid Form, Bid Item No. 32 is the only lump sum item in the Contract (= Total of all Lump Sum Items). On page 9 of the Bid Form, there is a box to add the Lump Sum Total + Unit Price Total. That total equals the Total Bid Price.

2. **Question:** Is it possible for bypass pumping to be paid under an allowance? Due to the fact that there are too many unknowns in determining the requirements for bypass pumping, flow of sewer, pump discharge requirements, traffic control requirements, ramps, duration of time for bypass, etc.

**Response:** The Contractor is ultimately responsible for managing sanitary flows and they shall make their own assumptions about bypass pumping for the range of pipe diameters in the specific contract bid items. However, where extensive bypass pumping efforts are required to complete the work (defined as either requiring: bypass of sanitary sewerlines greater than 12-inch diameter; installation or use of traffic ramps; discharge hose in lengths in excess of a typical manhole to manhole section; and/or a setup that necessitates specific traffic control requirements, or certain other scenarios if approved by the Engineer), the bypass pumping work would be considered outside the scope of work. In these instances, the bypass may be provided by Erie County personnel and would require coordination with the Contractor; or the out of scope work may be evaluated as additional work to be covered under the contract Contingency Item.

End of Document